

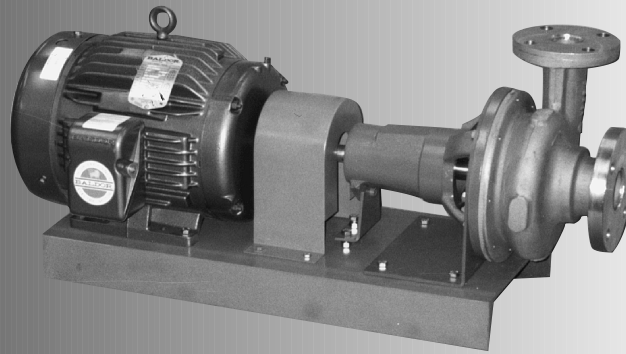

# Ampco Centrifugal Pumps

## Data Sheet



Model ZF 1<sup>1</sup>/<sub>2</sub> x 1<sup>1</sup>/<sub>4</sub>  
Nickel Aluminum Bronze

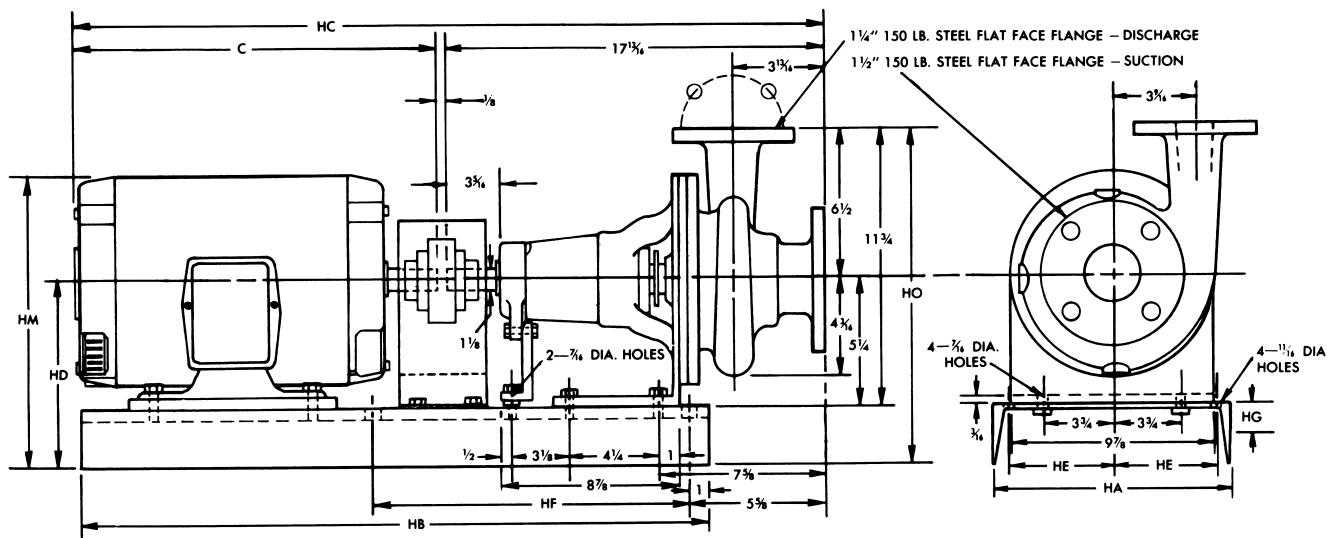

TEFC MOTOR			DIMENSIONS IN INCHES (For Reference Only)									
HP	RPM	FRAME	C	HA	HB	HC	HD	HE	HF	HG	HM	HO
1	1750	143T	13-1/16	10	26	31	7-7/8	3-3/4	24	2-5/8	11-3/4	14-3/8
2	3500	145T	13-1/16	10	26	31	7-7/8	3-3/4	24	2-5/8	11-3/4	14-3/8
3	3500	182T	15-3/8	10	26	33-5/16	7-7/8	3-3/4	16-1/4	2-5/8	12-1/2	14-3/8
5	3500	184T	15-3/8	10	26	33-5/16	7-7/8	3-3/4	16-1/4	2-5/8	12-1/2	14-3/8
7-1/2	3500	213T	19-7/16	12	28	37-3/8	8-1/4	4-1/2	17-1/2	3	13-3/4	14-3/4

### MATERIAL SPECIFICATIONS

PART NAME	NICKEL ALUMINUM BRONZE
Casing, Cover & Impeller	AMPCO® 483
Wear Ring	AMPCO® 18
Shaft	Steel
Shaft Sleeve	AMPCO® 18
Frame	Cast Iron

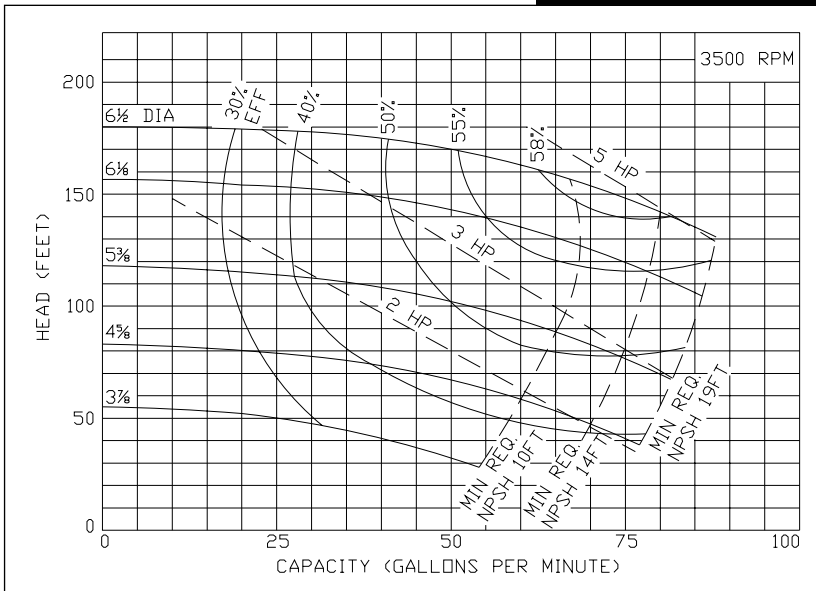
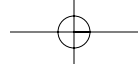

# Ampco Centrifugal Pumps

Model ZF 1 1/2 x 1 1/4  
Nickel Aluminum Bronze

Curves show approximate characteristics based on clear 68° water. Rated point is guaranteed.

Heavy-duty Z Series pumps have maximum wall thickness and 150 lb. flat faced flanged connections.

Seal options include Type 21, Type 1 and Type 9 with choice of sealing materials.

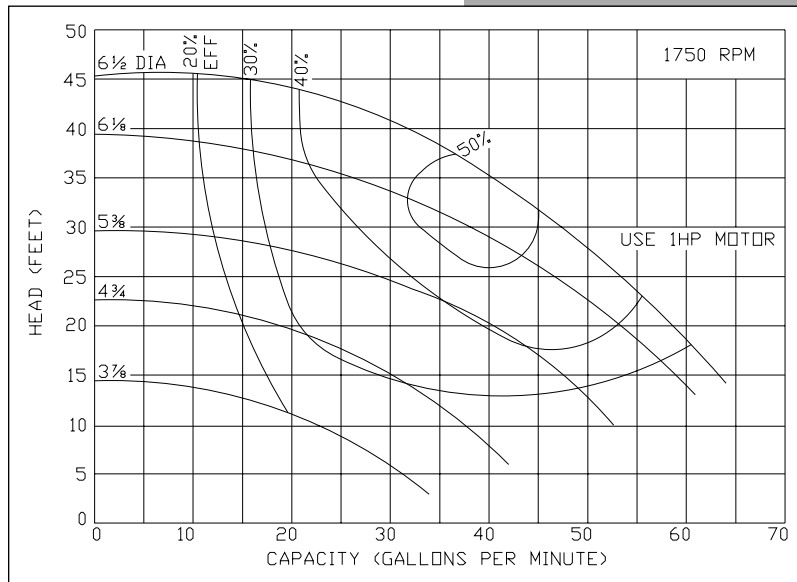
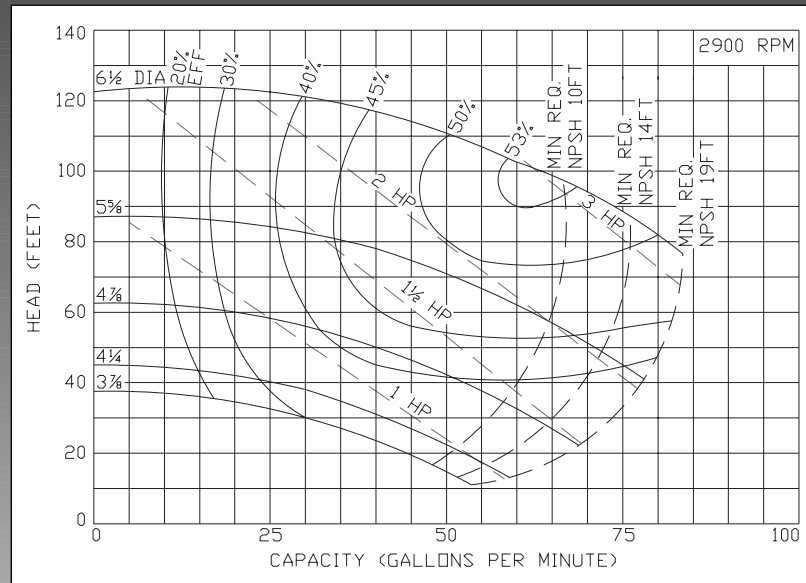

# Ampco Pumps Company

4424 West Mitchell Street  
Milwaukee, Wisconsin 53214  
PHONE (414) 643-1852  
FAX (414) 643-4452

