

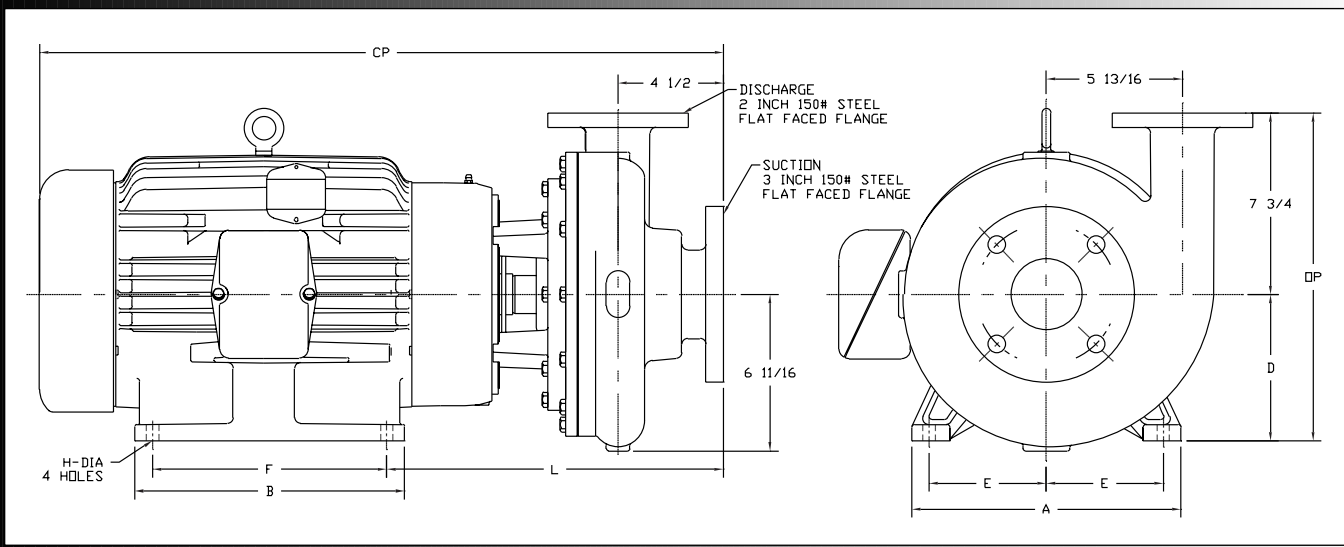

Ampco Centrifugal Pumps

Data Sheet

Model ZC2/ZCH2 3x2



TEFC MOTOR			DIMENSIONS IN INCHES (For Reference Only)									APPROX. WEIGHT (LBS)
HP	RPM	FRAME	A (typ)	B (typ)	D	E	F	H	L	CP	OP	
3	1750	182JM	8-5/8	6-1/2	4-1/2	3-3/4	4-1/2	13/32	12-1/8	21-1/4	12-1/4	179
5	1750	184JM	8-5/8	6-1/2	4-1/2	3-3/4	5-1/2	13/32	12-1/8	22-3/4	12-1/4	203
7-1/2	1750	213JM	9-1/2	8	5-1/4	4-1/2	5-1/2	13/32	13-1/8	24-1/4	13	254
10	1750	215JM	9-1/2	8	5-1/4	4-1/4	7	13/32	13-1/8	25-3/8	13	266
20	3500	256JM	11-1/2	11-1/2	6-1/4	5	10	17/32	14-3/8	29-1/4	14	368
25	3500	284JM	12-3/4	12-3/4	7	5-1/2	9-1/2	17/32	14-3/8	32-7/8	14-3/4	517
30	3500	286JM	12-3/4	12-3/4	7	5-1/2	11	17/32	14-3/8	33-7/16	14-3/4	532
40	3500	324JM	14	12	8	6-1/4	10-1/2	21/32	14-7/8	34-3/4	15-3/4	604
50	3500	326JM	14-1/2	14	8	6-1/4	12	21/32	14-7/8	34-3/4	15-3/4	654

MATERIAL SPECIFICATIONS

PART NAME	NICKEL ALUMINUM BRONZE	STAINLESS STEEL
Casing, Cover & Impeller	AMPCO® 483	316 Stainless
Wear Rings	AMPCO® 18	316 Stainless
Motor Shaft	Steel	Steel
Shaft Sleeve	AMPCO® 18	316 Stainless
Adapter	Cast Iron	Cast Iron

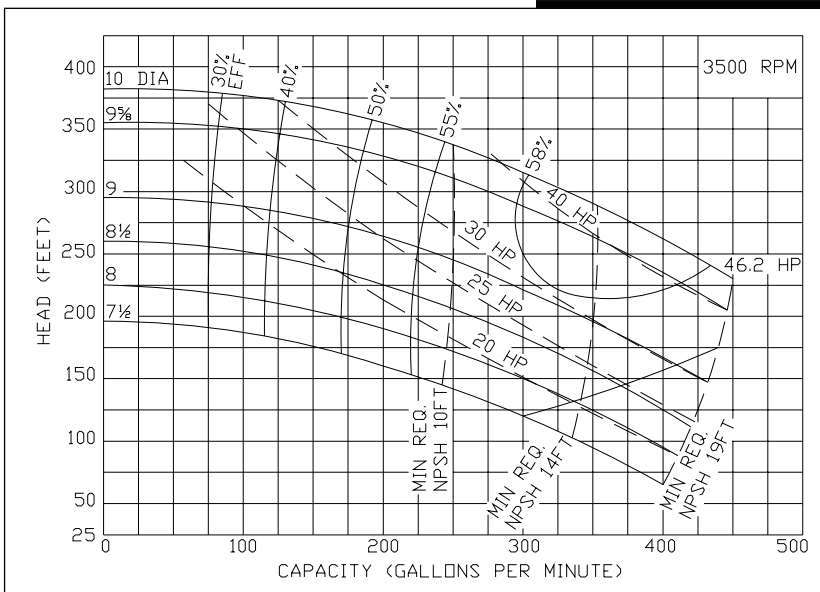

Ampco Centrifugal Pumps

Model ZC2/ZCH2 3x2

Curves show approximate characteristics based on clear 68° water. Rated point is guaranteed.

Heavy-duty Z Series pumps have maximum wall thickness and 150 lb. flat faced flanged connections.

Seal options include Type 21, Type 1 and Type 9 with choice of sealing materials.

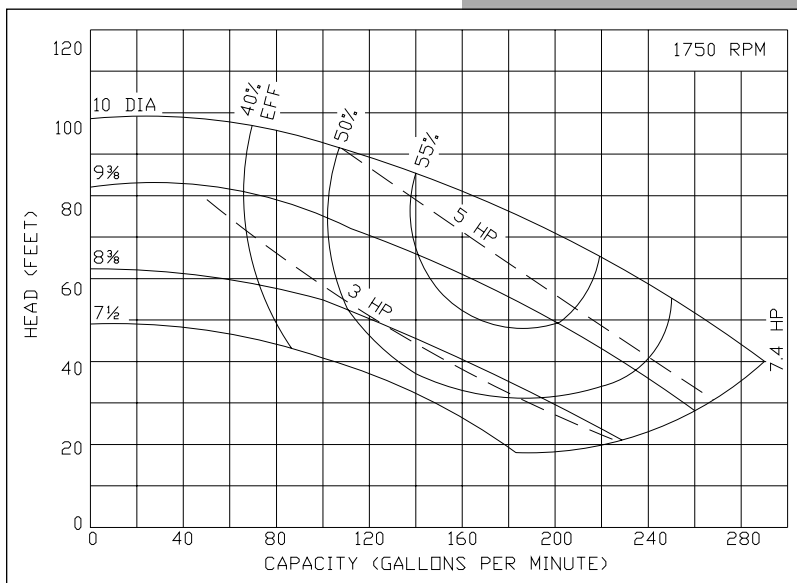
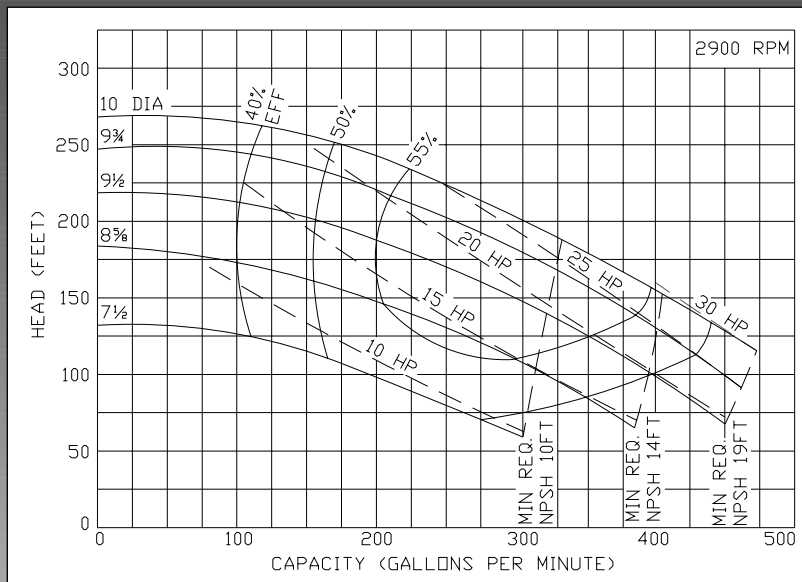

Ampco Pumps Company

4424 West Mitchell Street
 Milwaukee, Wisconsin 53214
 PHONE (414) 643-1852
 FAX (414) 643-4452