

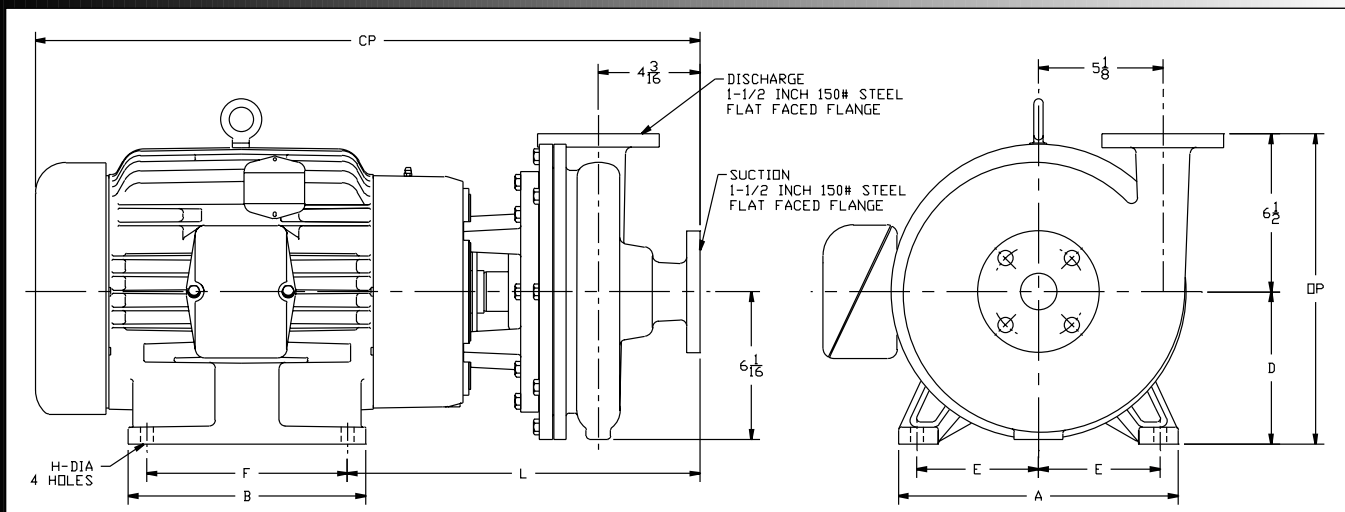

Ampco Centrifugal Pumps

Data Sheet

Model ZC2/ZCH2 1 1/2 x 1 1/2



TEFC MOTOR			DIMENSIONS IN INCHES (For Reference Only)									APPROX. WEIGHT (LBS)
HP	RPM	FRAME	A (typ)	B (typ)	D	E	F	H	L	CP	OP	
1	1750	143JM	6-1/2	6	3-1/2	2-3/4	4	11/32	11-3/8	19-11/16	10	135
1-1/2	1750	145JM	6-1/2	6	3-1/2	2-3/4	5	11/32	11-3/8	19-11/16	10	139
2	1750	145JM	6-1/2	6	3-1/2	2-3/4	5	11/32	11-3/8	19-11/16	10	146
3	1750	182JM	8-5/8	6-1/2	4-1/2	3-3/4	4-1/2	13/32	12	21-3/32	11	155
5	3500	184JM	8-5/8	6-1/2	4-1/2	3-3/4	5-1/2	13/32	12	22-7/16	11	189
7-1/2	3500	213JM	9-5/8	8-1/8	5-1/4	4-1/4	5-1/2	13/32	13	25-5/16	11-3/4	257
10	3500	215JM	9-5/8	8-1/8	5-1/4	4-1/4	7	13/32	13	25-5/16	11-3/4	275
15	3500	254JM	11-1/2	9-3/4	6-1/4	5	8-1/4	17/32	14-1/2	27-5/16	12-3/4	323
20	3500	256JM	11-1/2	11-1/2	6-1/4	5	10	17/32	14-1/2	29-3/32	12-3/4	362

MATERIAL SPECIFICATIONS

PART NAME	NICKEL ALUMINUM BRONZE	STAINLESS STEEL
Casing, Cover & Impeller	AMPCO® 483	316 Stainless
Wear Rings	AMPCO® 18	316 Stainless
Motor Shaft	Steel	Steel
Shaft Sleeve	AMPCO® 18	316 Stainless
Adapter	Cast Iron	Cast Iron

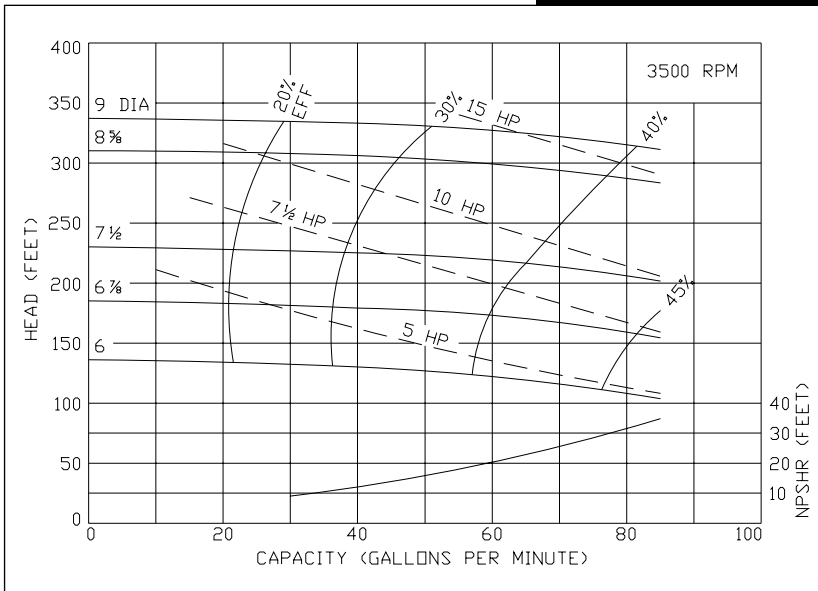
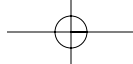

Ampco Centrifugal Pumps

Model ZC2/ZCH2 1 1/2 x 1 1/2

Curves show approximate characteristics based on clear 68° water. Rated point is guaranteed.

Heavy-duty Z Series pumps have maximum wall thickness and 150 lb. flat faced flanged connections.

Seal options include Type 21, Type 1 and Type 9 with choice of sealing materials.

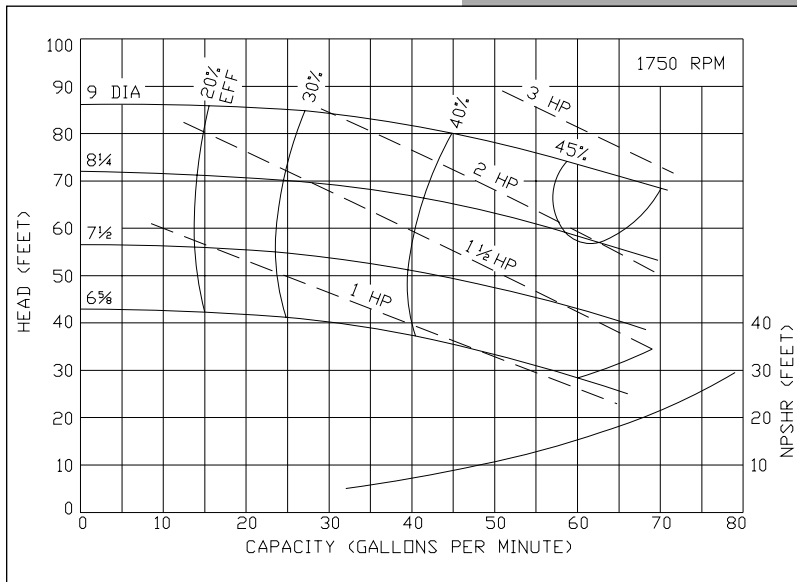
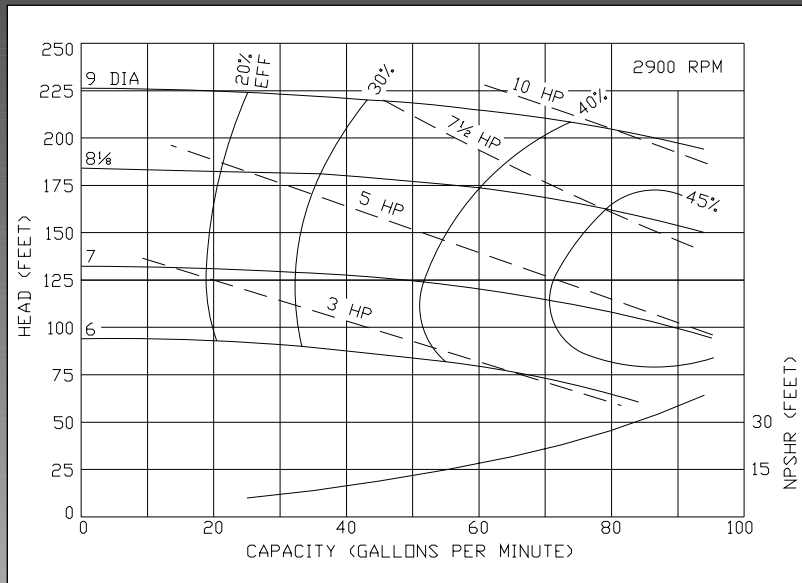

Ampco Pumps Company

4424 West Mitchell Street
Milwaukee, Wisconsin 53214
PHONE (414) 643-1852
FAX (414) 643-4452

