

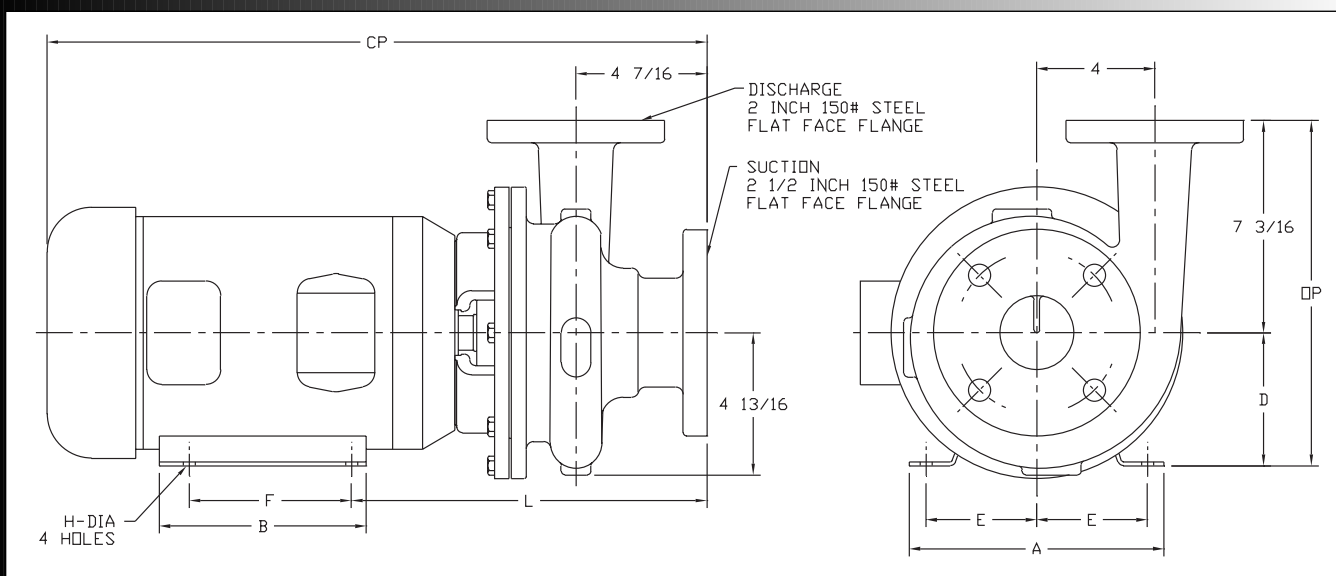

Ampco Centrifugal Pumps

Data Sheet

Model ZC2 2 1/2 x 2



TEFC MOTOR			DIMENSIONS IN INCHES (For Reference Only)									APPROX. WEIGHT (LBS)
HP	RPM	FRAME	A (max)	B (max)	D	E	F	H	L	CP	OP	
1	1750	143JM	6-1/2	6	3-1/2	2-3/4	4	11/32	11-1/2	19-15/16	10-11/16	118
1-1/2	1750	145JM	6-1/2	6	3-1/2	2-3/4	5	11/32	11-1/2	19-15/16	10-11/16	122
2	1750	145JM	6-1/2	6	3-1/2	2-3/4	5	11/32	11-1/2	19-15/16	10-11/16	128
3	1750	182JM	8-5/8	6-1/2	4-1/2	3-3/4	4-1/2	13/32	12-1/8	21-3/16	11-11/16	154
5	3500	184JM	8-5/8	6-1/2	4-1/2	3-3/4	5-1/2	13/32	12-1/8	22-9/16	10-11/16	167
7-1/2	3500	213JM	9-5/8	8-1/8	5-1/4	4-1/4	5-1/2	13/32	12-7/8	25-7/16	12-7/16	235
10	3500	215JM	9-5/8	8-1/8	5-1/4	4-1/4	7	13/32	12-7/8	25-7/16	12-7/16	253
15	3500	215JM	9-1/2	8	5-1/4	4-1/4	7	13/32	13-1/8	25-9/16	12-7/16	211

MATERIAL SPECIFICATIONS

PART NAME	NICKEL ALUMINUM BRONZE	STAINLESS STEEL
Casing, Cover & Impeller	AMPCO® 483	316 Stainless
Wear Ring	AMPCO® 18	316 Stainless
Motor Shaft	Steel	Steel
Shaft Sleeve	AMPCO® 18	316 Stainless
Adapter	Cast Iron	Cast Iron

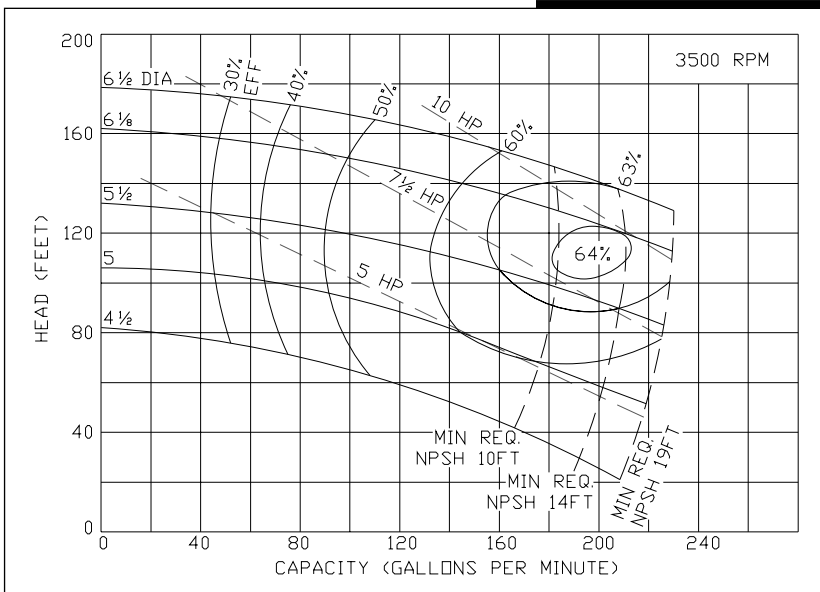

Ampco Centrifugal Pumps

Model ZC2 2 1/2 x 2

Curves show approximate characteristics based on clear 68° water. Rated point is guaranteed.

Heavy-duty Z Series pumps have maximum wall thickness and 150 lb. flat faced flanged connections.

Seal options include Type 21, Type 1 and Type 9 with choice of sealing materials.

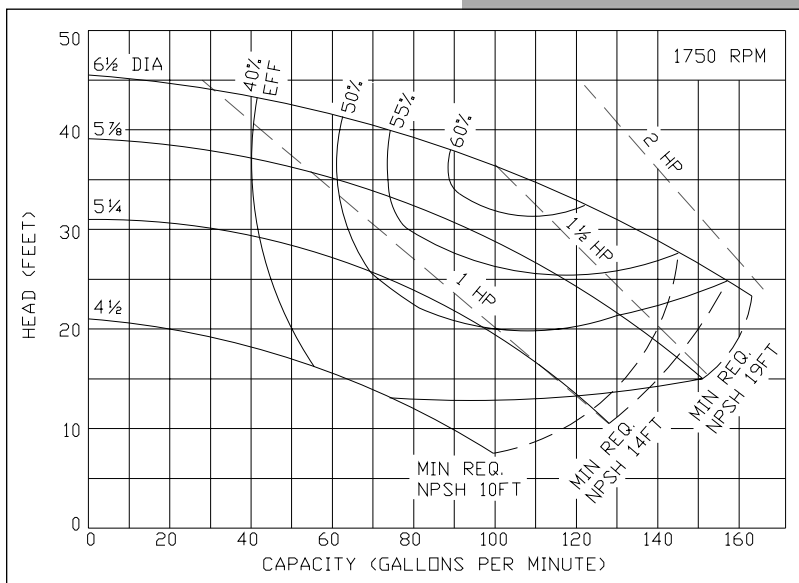
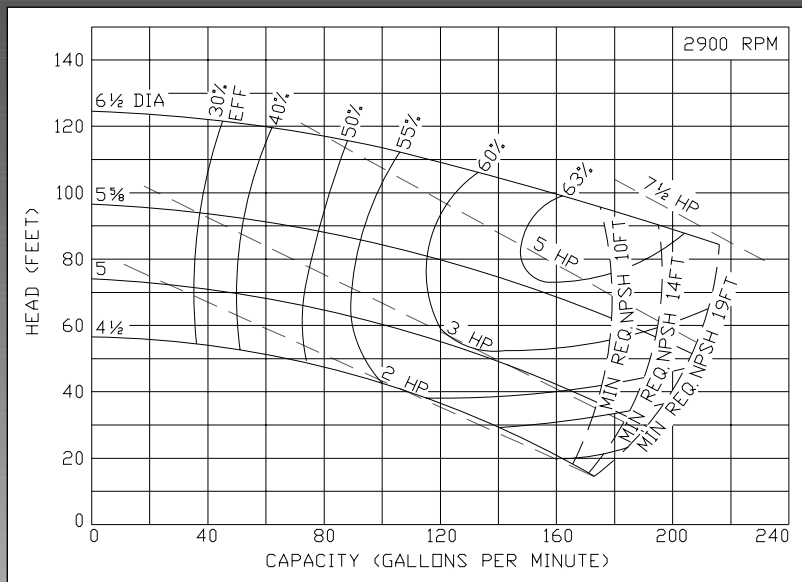

Ampco Pumps Company

4424 West Mitchell Street
 Milwaukee, Wisconsin 53214
 PHONE (414) 643-1852
 FAX (414) 643-4452