

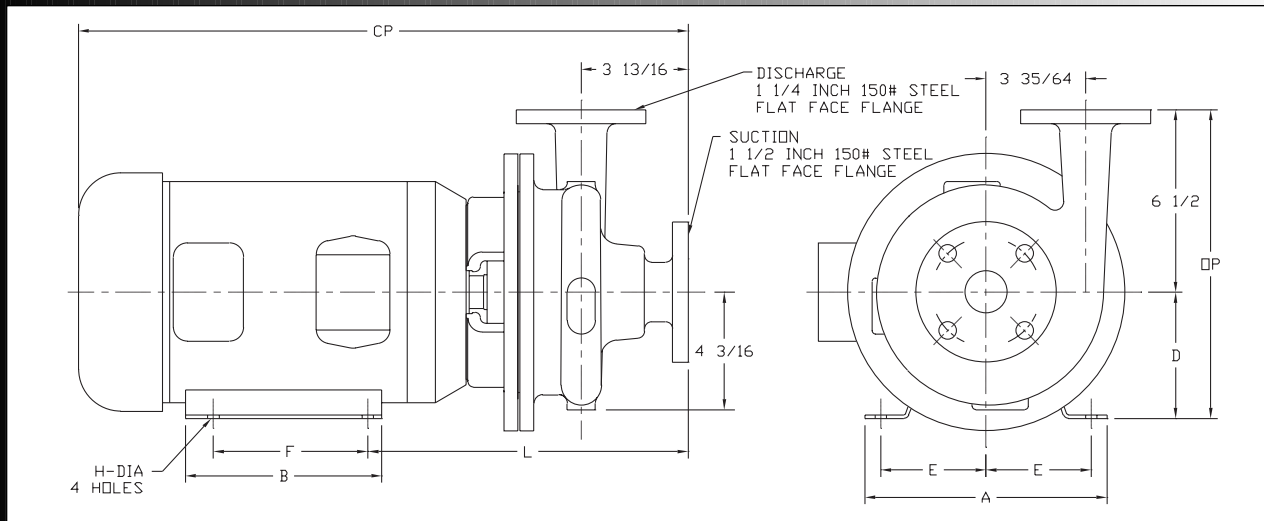

# Ampco Centrifugal Pumps

## Data Sheet

Model ZC2 1 1/2 x 1 1/4  
Nickel Aluminum Bronze



TEFC MOTOR			DIMENSIONS IN INCHES (For Reference Only)									APPROX. WEIGHT (LBS)
HP	RPM	FRAME	A	B	D	E	F	H	L	CP	OP	
1	1750	143JM	6-1/2	6	3-1/2	2-3/4	4	11/32	10-7/8	19-3/16	10	110
1-1/2	1750	145JM	6-1/2	6	3-1/2	2-3/4	5	11/32	10-7/8	19-3/16	10	114
2	1750	145JM	6-1/2	6	3-1/2	2-3/4	5	11/32	10-7/8	19-3/16	10	120
2	3500	145JM	6-1/2	6	3-1/2	2-3/4	5	11/32	10-7/8	19-3/16	10	120
3	3500	145JM	6-1/2	6	3-1/2	2-3/4	5	11/32	10-7/8	19-3/16	11	146
5	3500	184JM	8-5/8	6-1/2	4-1/2	3-3/4	5-1/2	13/32	11-1/2	22	11	159
7-1/2	3500	213JM	9-5/8	8-1/8	5-1/4	4-1/4	5-1/2	13/32	13	25	11-3/4	227

### MATERIAL SPECIFICATIONS

PART NAME	NICKEL ALUMINUM BRONZE
Casing, Cover & Impeller	AMPCO® 483
Wear Ring	AMPCO® 18
Motor Shaft	Steel
Shaft Sleeve	AMPCO® 18
Adapter	Cast Iron

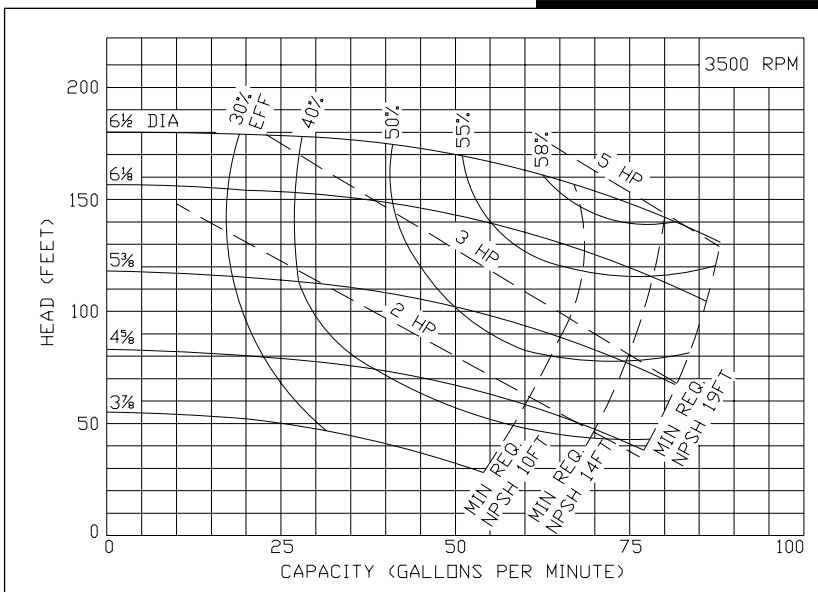

# Ampco Centrifugal Pumps

Model ZC2 1 1/2 x 1 1/4  
Nickel Aluminum Bronze

Curves show approximate characteristics based on clear 68° water. Rated point is guaranteed.

Heavy-duty Z Series pumps have maximum wall thickness and 150 lb. flat faced flanged connections.

Seal options include Type 21, Type 1 and Type 9 with choice of sealing materials.

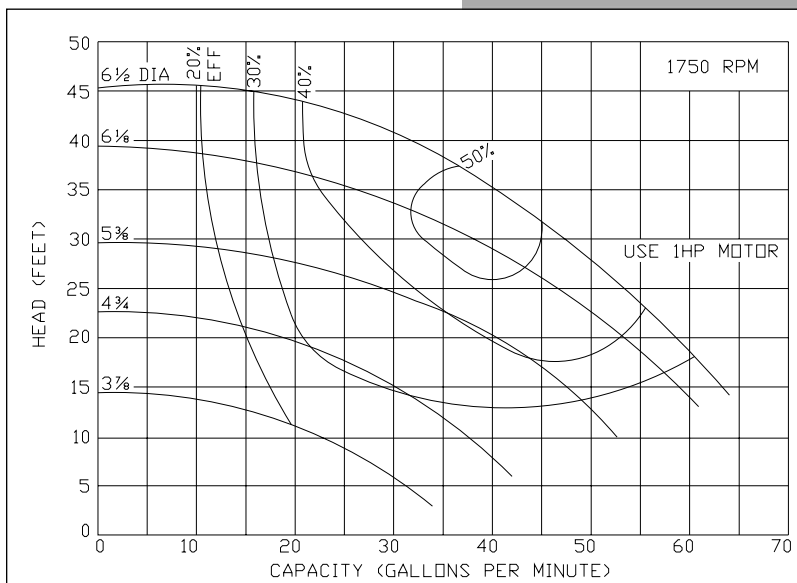
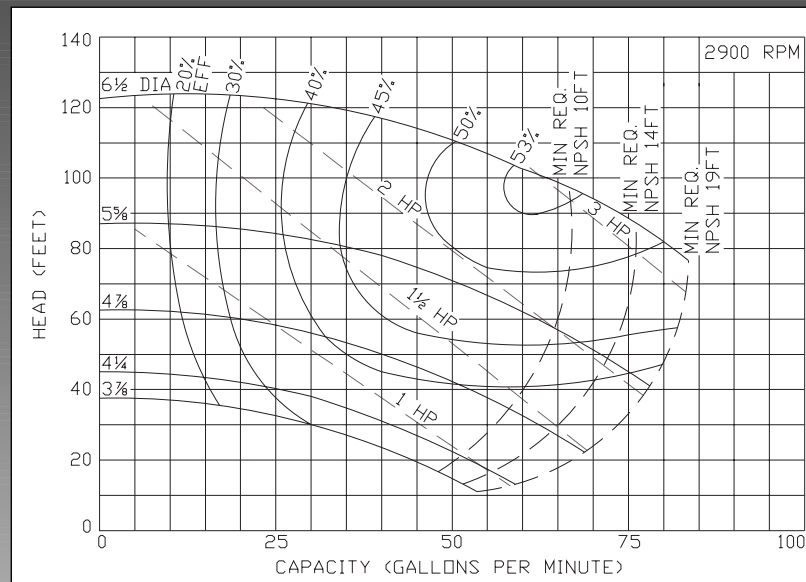

# Ampco Pumps Company

4424 West Mitchell Street  
Milwaukee, Wisconsin 53214  
PHONE (414) 643-1852  
FAX (414) 643-4452