

Ampco Centrifugal Pumps

DATA SHEET

MODEL KC2 1X^{3/4}
NICKEL ALUMINUM BRONZE

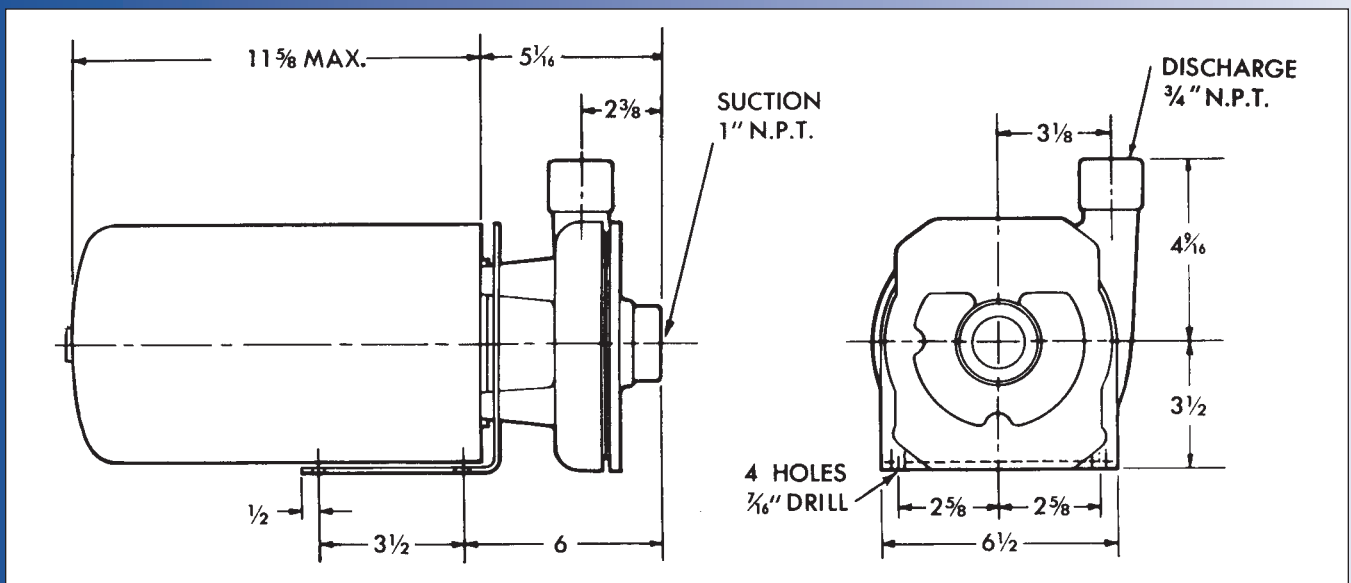
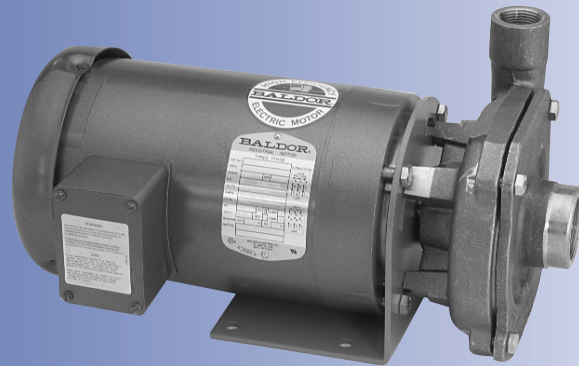

HP	FRAME	APPROX. WEIGHT (LBS)
1/2	56J	46
3/4	56J	48
1	56J	52
2	56J	61

MATERIAL SPECIFICATIONS

PART NAME	NICKEL ALUMINUM BRONZE
Casing	AMPCO® 483
Cover	AMPCO® 483
Impeller	AMPCO® 483
Bracket	Steel

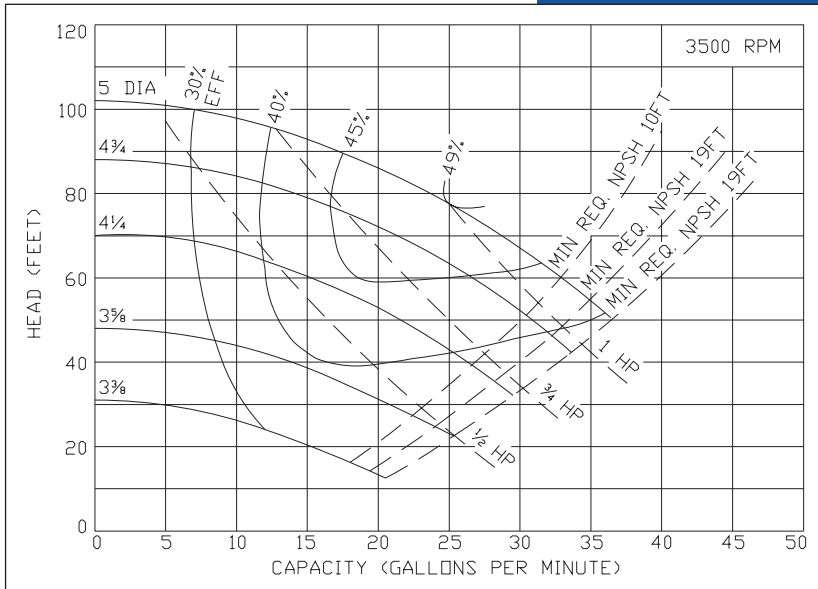

Ampco Centrifugal Pumps

MODEL KC2 1X³/₄
NICKEL ALUMINUM BRONZE

Curves show approximate characteristics based on clear 68° water. Rated point is guaranteed.

Standard K Series pumps have threaded NPT connections and are mounted on 56J frame motors. Seal options include Type 21 and Type 9 with choice of sealing materials.

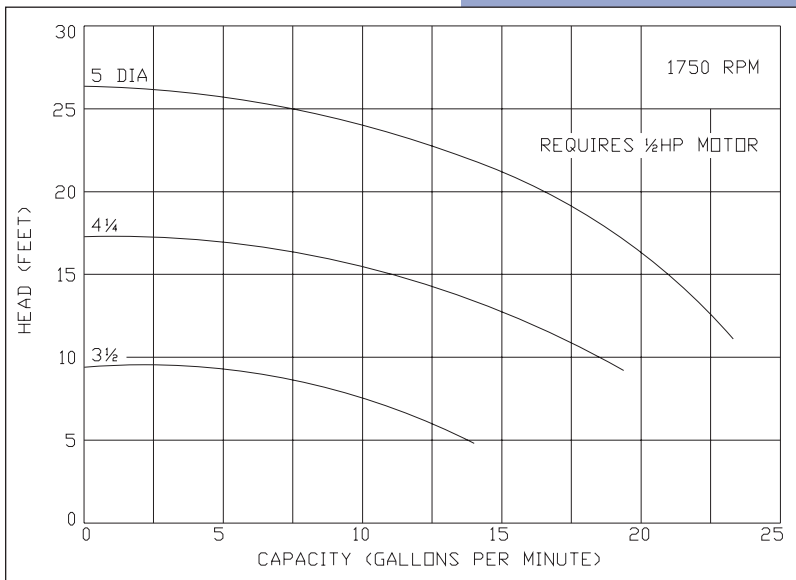
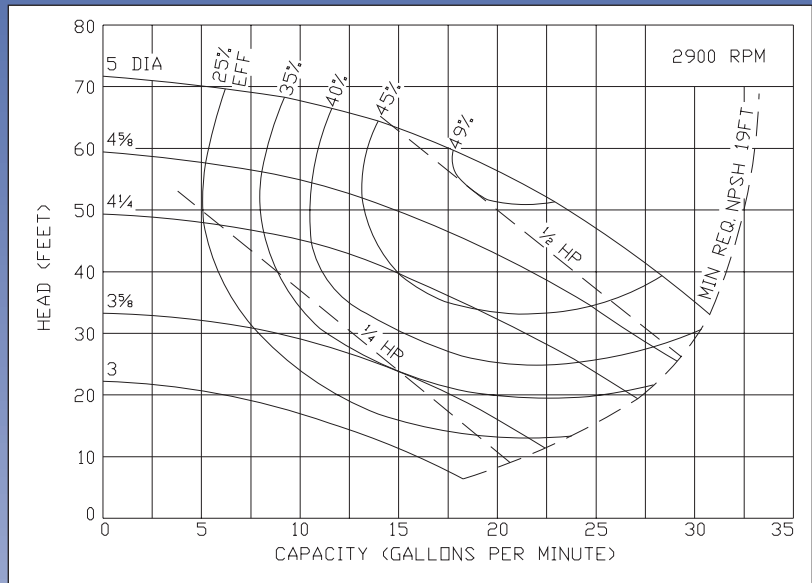

Ampco Pumps Company

4424 West Mitchell Street
 Milwaukee, Wisconsin 53214
 PHONE (414) 643-1852
 FAX (414) 643-4452

Ampco Centrifugal Pumps

DATA SHEET

MODEL KC2 1X^{3/4}
STAINLESS STEEL

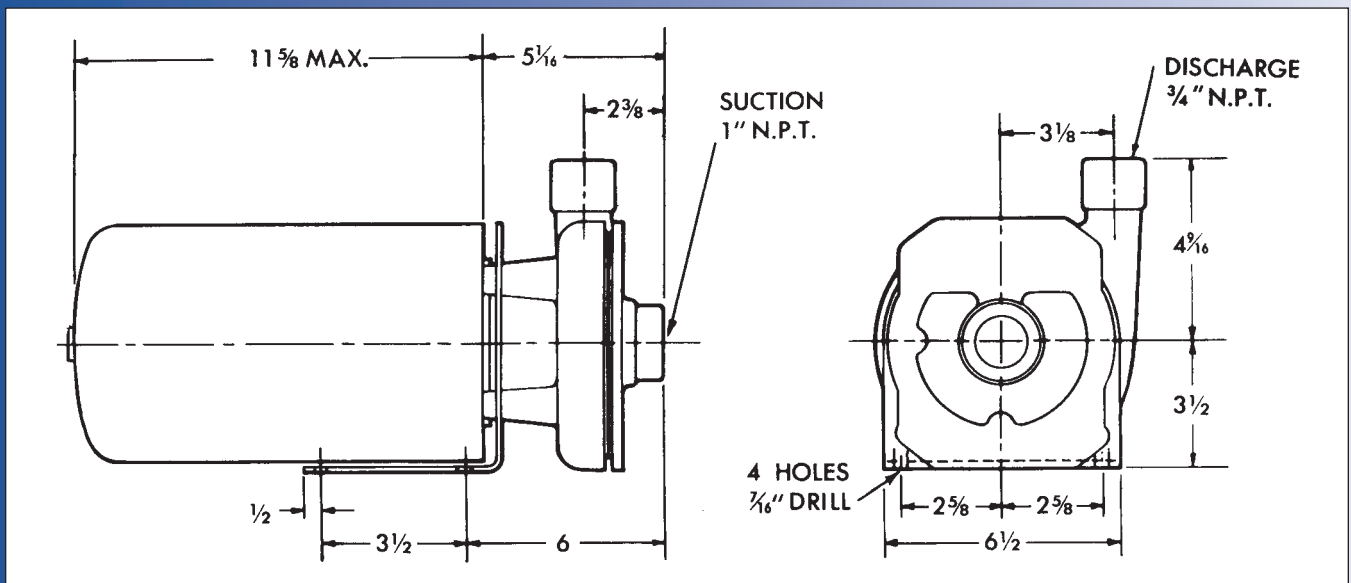
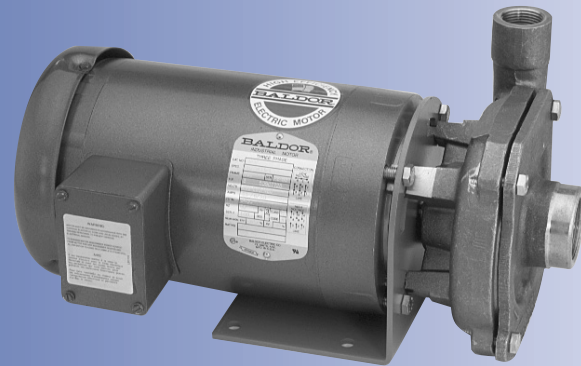

HP	FRAME	APPROX. WEIGHT (LBS)
1/2	56J	46
3/4	56J	48
1	56J	52
2	56J	61

MATERIAL SPECIFICATIONS

PART NAME	STAINLESS STEEL
Casing	316 Stainless
Cover	316 Stainless
Impeller	316 Stainless
Bracket	Steel

* Also available in Duplex 2205

Ampco Centrifugal Pumps

MODEL KC2 1X³/₄ STAINLESS STEEL

Curves show approximate characteristics
based on clear 68° water.
Rated point is guaranteed.

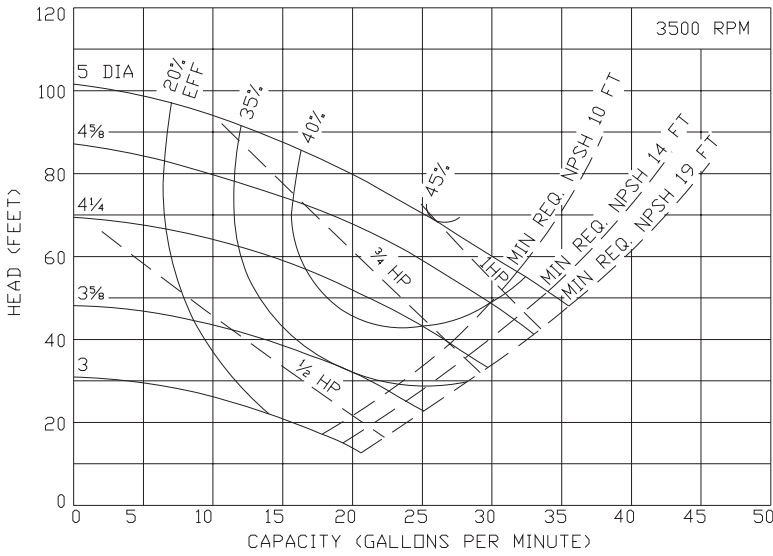

Standard K Series
pumps have threaded
NPT connections and
are mounted on 56J
frame motors.

Seal options include
Type 21 and Type 9 with
choice of sealing materials.

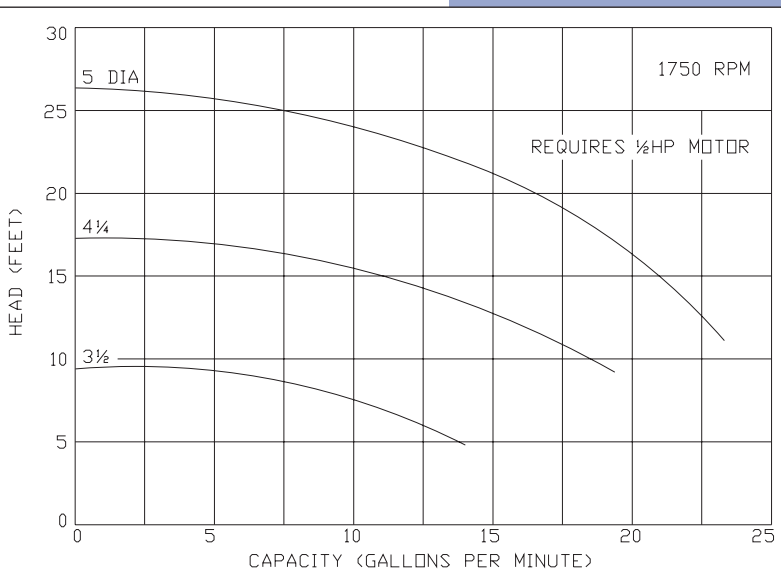
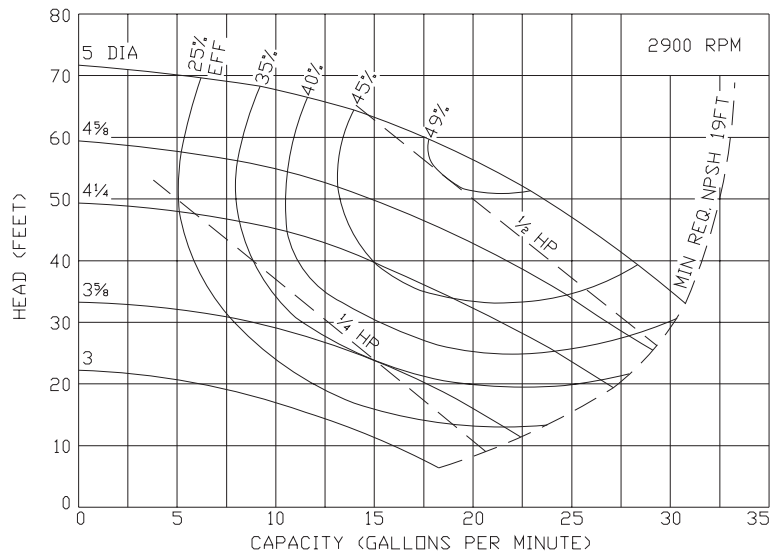

Ampco Pumps Company

4424 West Mitchell Street
Milwaukee, Wisconsin 53214
PHONE (414) 643-1852
FAX (414) 643-4452

Ampco Centrifugal Pumps

DATA SHEET

MODEL KC2 1 $\frac{1}{4}$ X 1

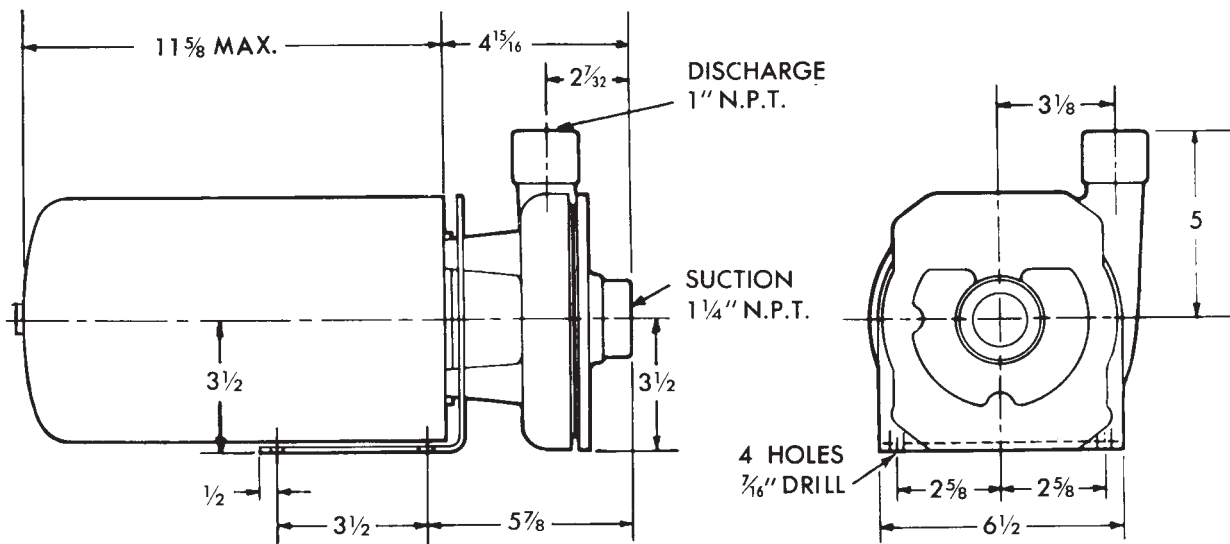

HP	FRAME	APPROX. WEIGHT (LBS)
1/2	56J	48
1	56J	50
1-1/2	56J	58
2	56J	63
3	56J	67

MATERIAL SPECIFICATIONS

PART NAME	NICKEL ALUMINUM BRONZE	STAINLESS STEEL
Casing	AMPCO® 483	316 Stainless
Cover	AMPCO® 483	316 Stainless
Impeller	AMPCO® 483	316 Stainless
Bracket	Steel	Steel

* Also available in Duplex 2205



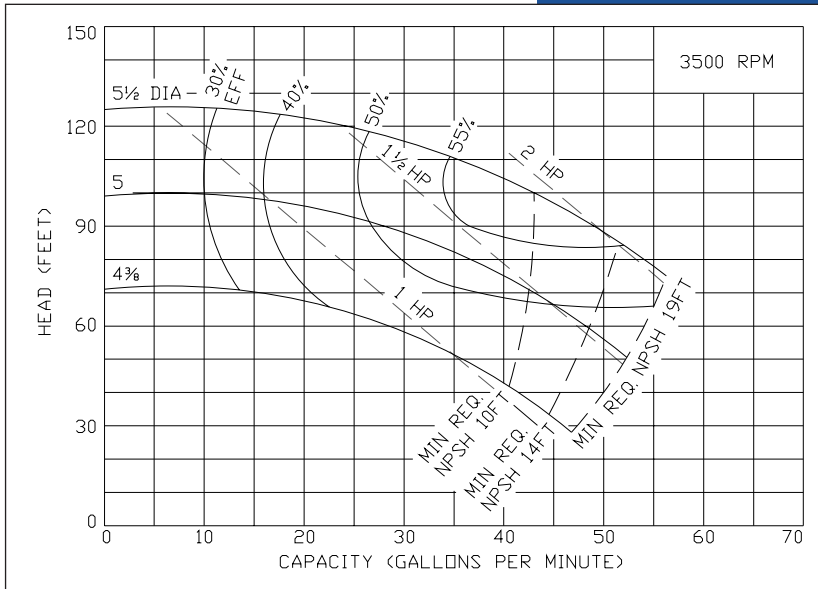

Ampco Centrifugal Pumps

MODEL KC2 1 1/4 X 1

Curves show approximate characteristics based on clear 68° water. Rated point is guaranteed.

Standard K Series pumps have threaded NPT connections and are mounted on 56J frame motors. Seal options include Type 21 and Type 9 with choice of sealing materials.

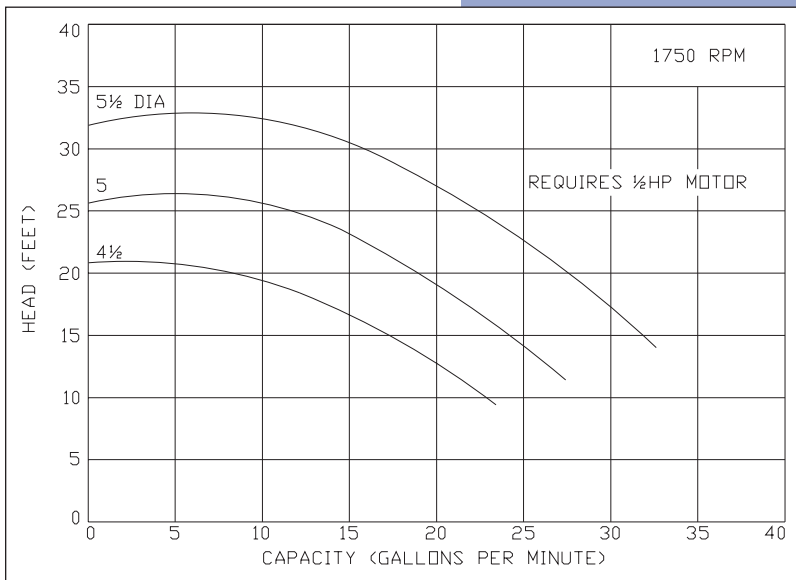
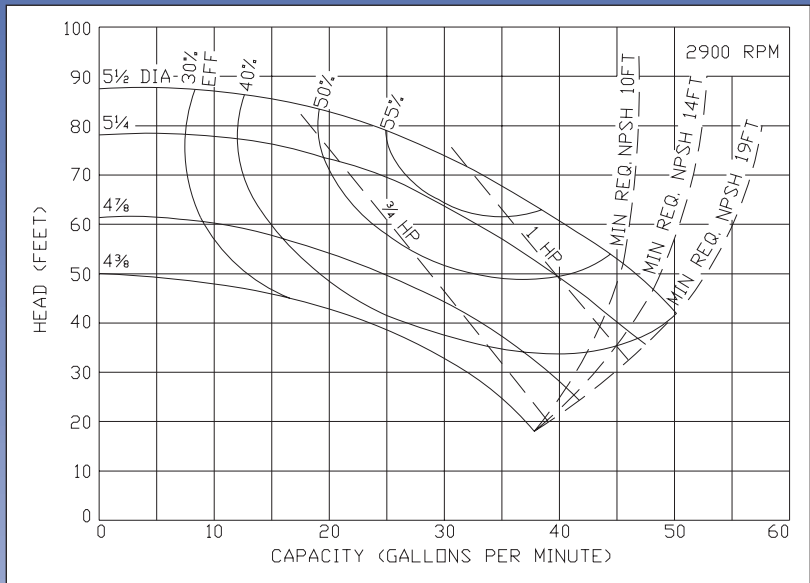

Ampco Pumps Company

4424 West Mitchell Street
 Milwaukee, Wisconsin 53214
 PHONE (414) 643-1852
 FAX (414) 643-4452

Ampco Centrifugal Pumps

DATA SHEET

MODEL KC2 1½ X 1

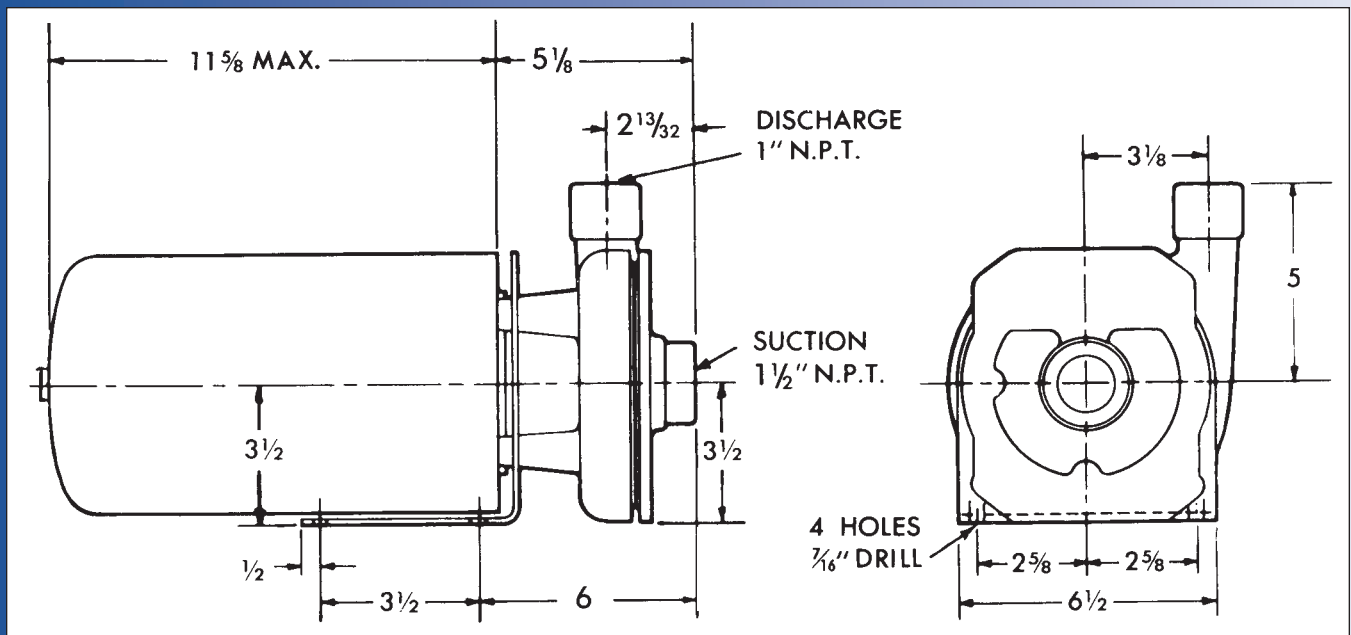

HP	FRAME	APPROX. WEIGHT (LBS)
1/2	56J	48
1	56J	50
2	56J	63
3	56J	67

MATERIAL SPECIFICATIONS

PART NAME	NICKEL ALUMINUM BRONZE	STAINLESS STEEL
Casing	AMPCO® 483	316 Stainless
Cover	AMPCO® 483	316 Stainless
Impeller	AMPCO® 483	316 Stainless
Bracket	Steel	Steel

* Also available in Duplex 2205

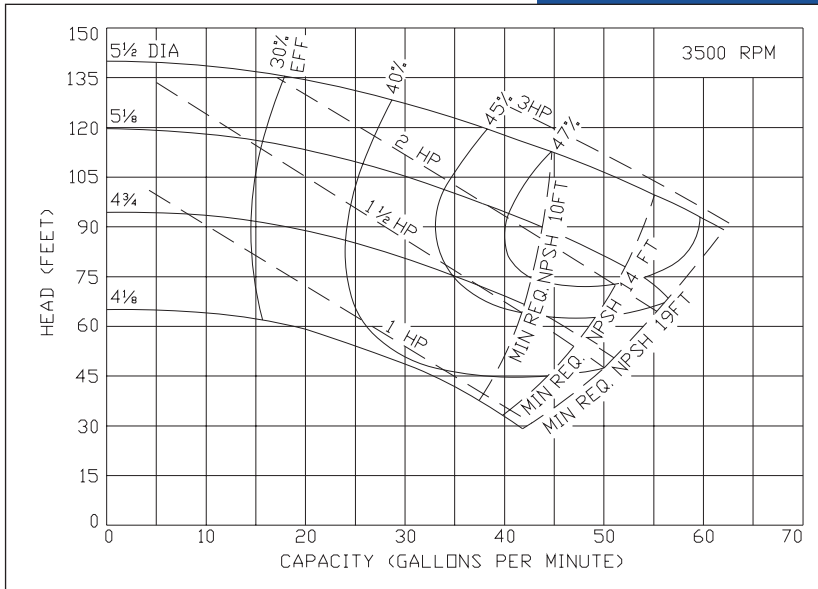

Ampco Centrifugal Pumps

MODEL KC2 1 1/2 X 1

Curves show approximate characteristics based on clear 68° water. Rated point is guaranteed.

Standard K Series pumps have threaded NPT connections and are mounted on 56J frame motors. Seal options include Type 21 and Type 9 with choice of sealing materials.

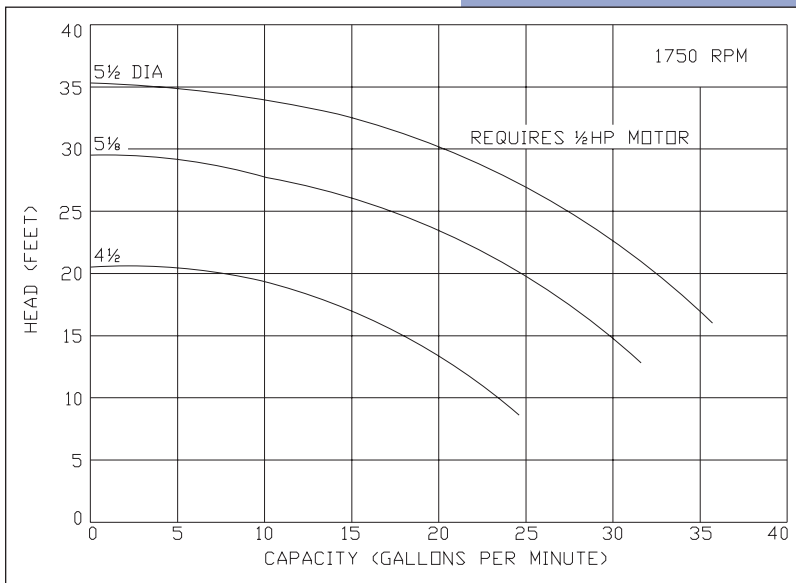
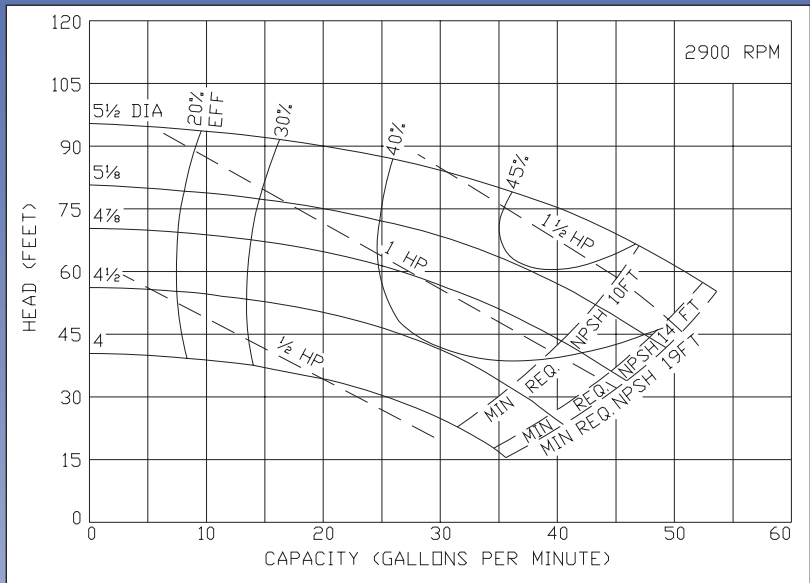

Ampco Pumps Company

4424 West Mitchell Street
 Milwaukee, Wisconsin 53214
 PHONE (414) 643-1852
 FAX (414) 643-4452

Ampco Centrifugal Pumps

DATA SHEET

MODEL KC2 1 1/2 X 1 1/4
NICKEL ALUMINUM BRONZE

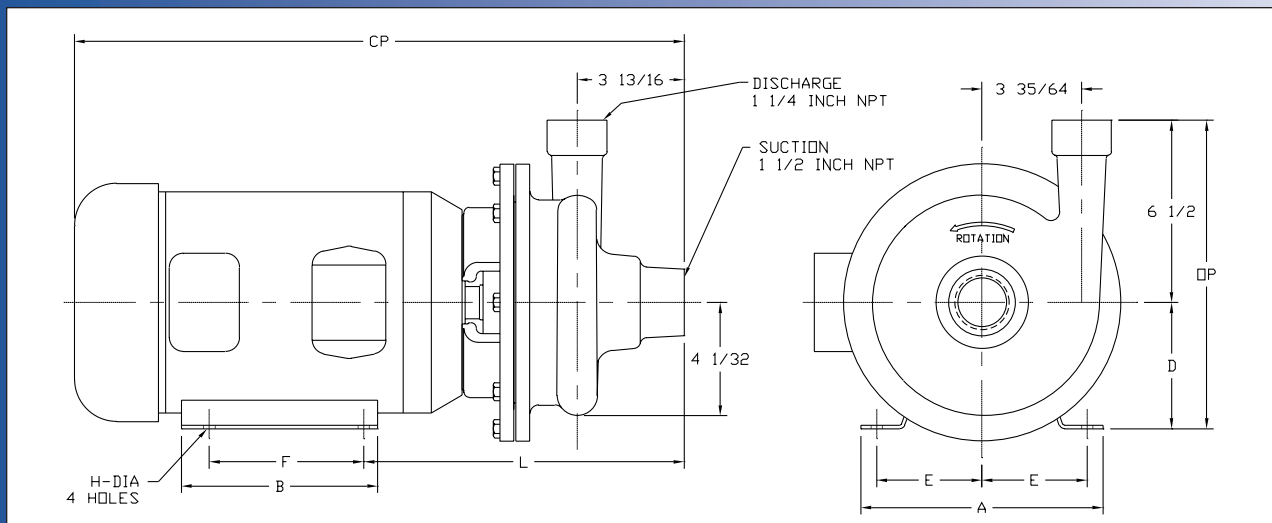
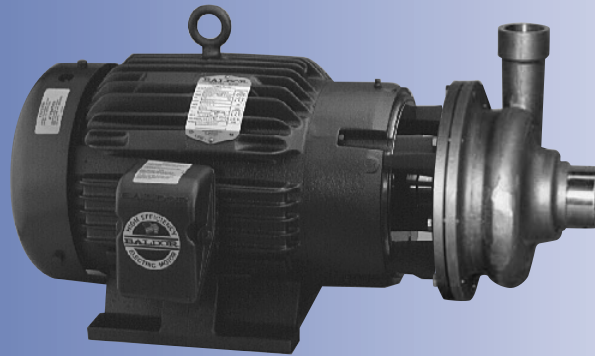

TEFC MOTOR			DIMENSIONS IN INCHES (For Reference Only)									APPROX. WEIGHT (LBS)
HP	RPM	FRAME	A	B	D	E	F	H	L	CP	OP	
1	1750	143JM	6-1/2	6	3-1/2	2-3/4	4	11/32	10-7/8	19-3/16	10	110
1-1/2	1750	145JM	6-1/2	6	3-1/2	2-3/4	5	11/32	10-7/8	19-3/16	10	114
2	1750	145JM	6-1/2	6	3-1/2	2-3/4	5	11/32	10-7/8	19-3/16	10	120
2	3500	145JM	6-1/2	6	3-1/2	2-3/4	5	11/32	10-7/8	19-3/16	10	120
3	3500	145JM	6-1/2	6	3-1/2	2-3/4	5	11/32	10-7/8	19-3/16	10	146
5	3500	184JM	8-5/8	6-1/2	4-1/2	3-3/4	5-1/2	13/32	11-1/2	22	11	159
7-1/2	3500	213JM	9-5/8	8-1/8	5-1/4	4-1/4	5-1/2	13/32	13	25	11-3/4	227

MATERIAL SPECIFICATIONS

PART NAME	NICKEL ALUMINUM BRONZE
Casing, Cover & Impeller	AMPCO® 483
Wear Ring	AMPCO® 18
Motor Shaft	Steel
Shaft Sleeve	AMPCO® 18
Adapter	Cast Iron

Ampco Centrifugal Pumps

**MODEL KC2 1½ X 1¼
NICKEL ALUMINUM BRONZE**

Curves show approximate characteristics based on clear 68° water. Rated point is guaranteed.

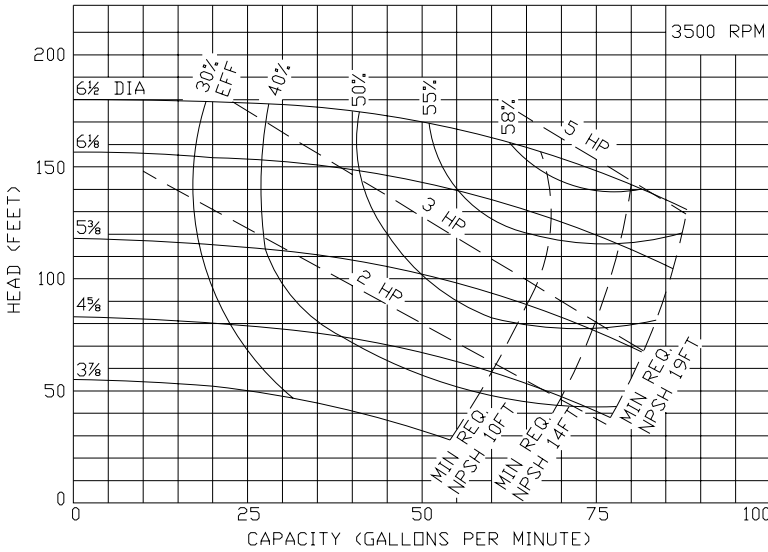

Standard K Series pumps have threaded NPT connections. Models 1½ x 1¼ and 2 x 1½ are mounted on JM frame motors and offer the same hydraulic performance as the comparable Z Series pump

Seal options include Type 21, Type 1 and Type 9 with choice of sealing materials.

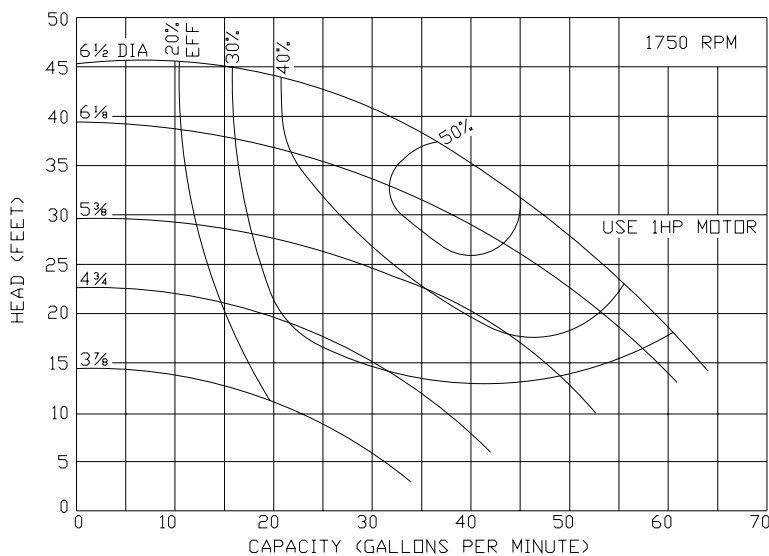
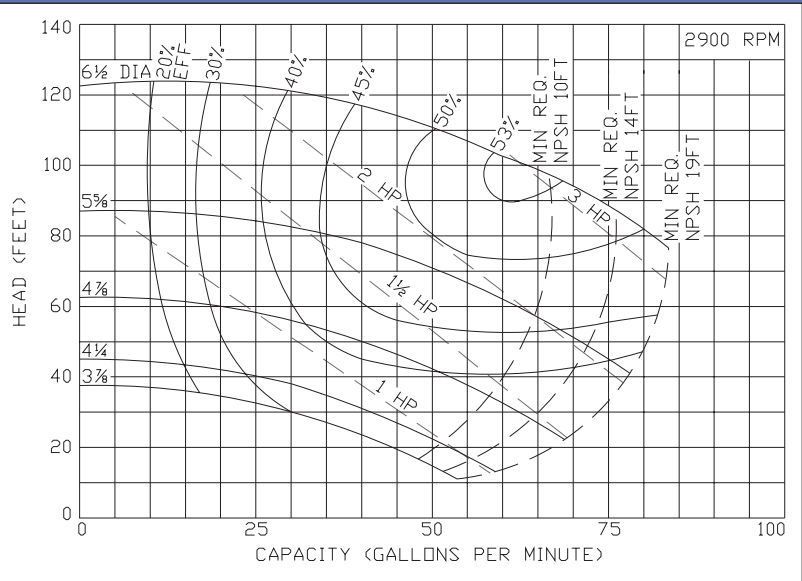

Ampco Pumps Company

4424 West Mitchell Street
Milwaukee, Wisconsin 53214
PHONE (414) 643-1852
FAX (414) 643-4452

Ampco Centrifugal Pumps

DATA SHEET

MODEL KC2 1 1/2 X 1 1/4
STAINLESS STEEL

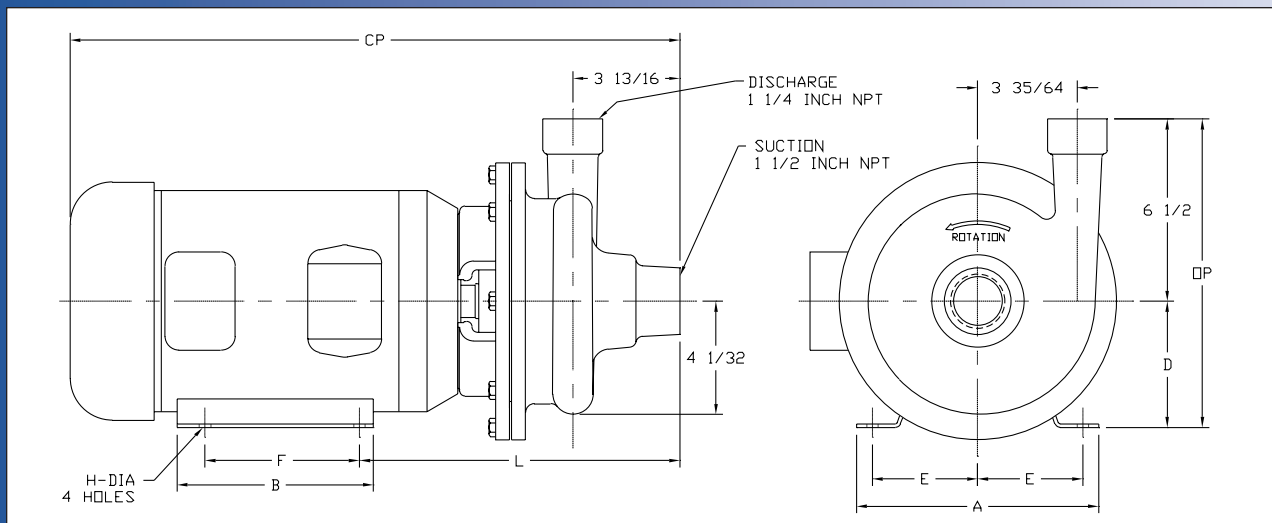
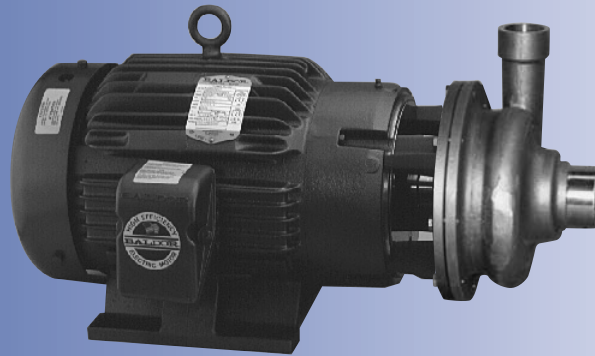

TEFC MOTOR			DIMENSIONS IN INCHES (For Reference Only)									APPROX. WEIGHT (LBS)
HP	RPM	FRAME	A (max)	B (max)	D	E	F	H	L	CP	OP	
1	1750	143JM	6-1/2	6	3-1/2	2-3/4	4	11/32	10-7/8	19-3/16	10	110
1-1/2	1750	145JM	6-1/2	6	3-1/2	2-3/4	5	11/32	10-7/8	19-3/16	10	114
2	1750	145JM	6-1/2	6	3-1/2	2-3/4	5	11/32	10-7/8	19-3/16	10	120
2	3500	145JM	6-1/2	6	3-1/2	2-3/4	5	11/32	10-7/8	19-3/16	10	120
3	3500	145JM	6-1/2	6	3-1/2	2-3/4	5	11/32	10-7/8	19-3/16	10	146
5	3500	184JM	8-5/8	6-1/2	4-1/2	3-3/4	5-1/2	13/32	11-1/2	22	11	159
7-1/2	3500	213JM	9-5/8	8-1/8	5-1/4	4-1/4	5-1/2	13/32	13	25	11-3/4	227

MATERIAL SPECIFICATIONS

PART NAME	STAINLESS STEEL
Casing, Cover & Impeller	316 Stainless
Wear Ring	316 Stainless
Motor Shaft	Steel
Shaft Sleeve	316 Stainless
Adapter	Cast Iron

* Also available in Duplex 2205

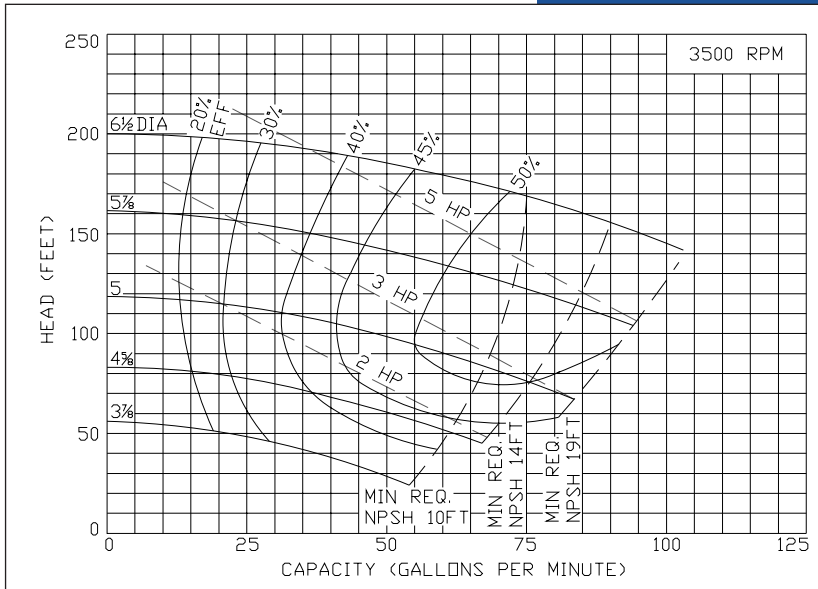

Ampco Centrifugal Pumps

MODEL KC2 1 1/2 X 1 1/4
STAINLESS STEEL

Curves show approximate characteristics based on clear 68° water. Rated point is guaranteed.

Standard K Series pumps have threaded NPT connections. Models 1 1/2 x 1 1/4 and 2 x 1 1/2 are mounted on JM frame motors and offer the same hydraulic performance as the comparable Z Series pump

Seal options include Type 21, Type 1 and Type 9 with choice of sealing materials.

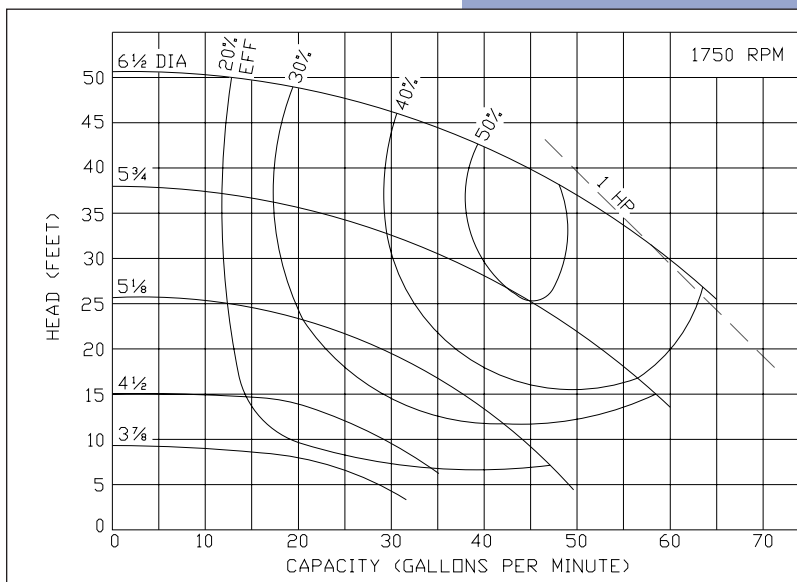
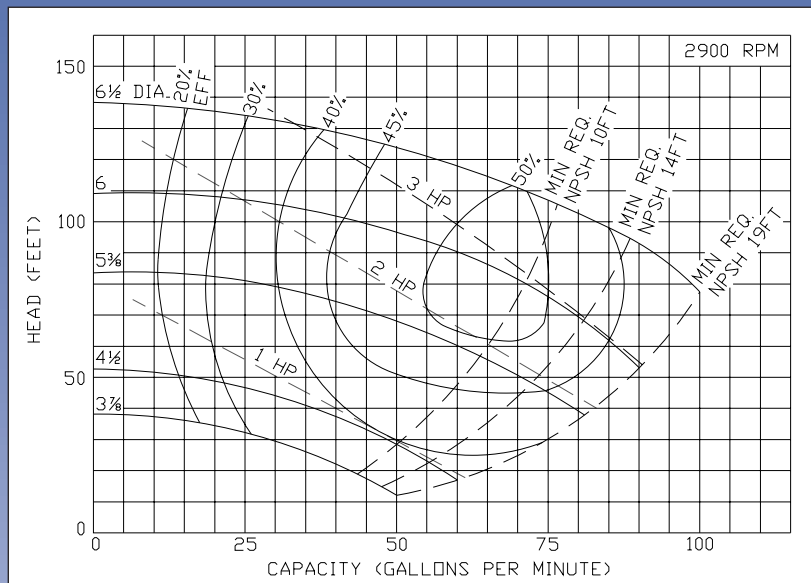

Ampco Pumps Company

4424 West Mitchell Street
Milwaukee, Wisconsin 53214
PHONE (414) 643-1852
FAX (414) 643-4452

Ampco Centrifugal Pumps

DATA SHEET

MODEL KC2 2 X 1 1/2

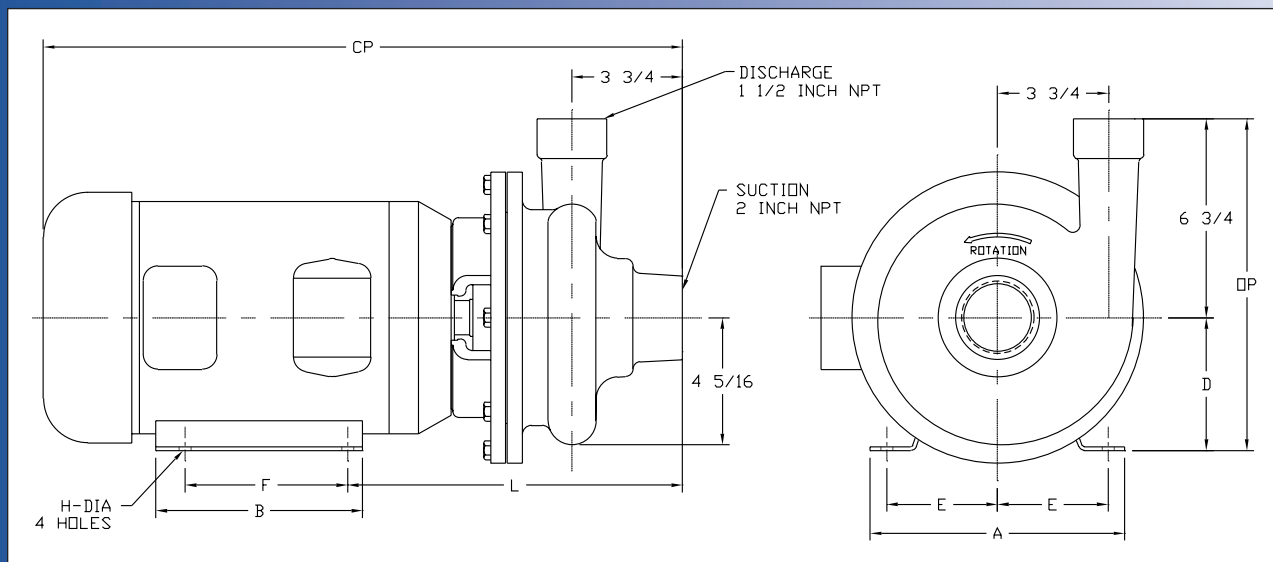
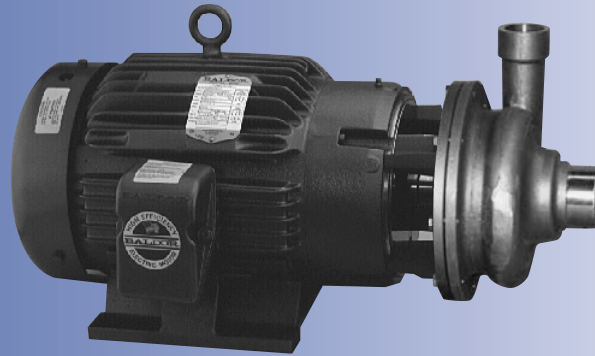

TEFC MOTOR			DIMENSIONS IN INCHES (For Reference Only)									APPROX. WEIGHT (LBS)
HP	RPM	FRAME	A (max)	B (max)	D	E	F	H	L	CP	OP	
1	1750	143JM	6-1/2	6	3-1/2	2-3/4	4	11/32	10-3/16	19-1/8	10-1/4	112
1-1/2	1750	145JM	6-1/2	6	3-1/2	2-3/4	5	11/32	10-3/16	19-1/8	10-1/4	116
2	1750	145JM	6-1/2	6	3-1/2	2-3/4	5	11/32	10-13/16	19-1/8	10-1/4	122
2	3500	145JM	6-1/2	6	3-1/2	2-3/4	5	11/32	10-13/16	19-1/8	10-1/4	122
3	3500	145JM	6-1/2	6	3-1/2	2-3/4	5	11/32	10-13/16	19-1/8	10-1/4	148
5	3500	184JM	8-5/8	6-1/2	4-1/2	3-3/4	5-1/2	13/32	11-7/16	21-15/16	11-1/4	161
7-1/2	3500	213JM	9-5/8	8-1/8	5-1/4	4-1/4	5-1/2	13/32	12-3/16	24-3/4	12	229
10	3500	215JM	9-5/8	8-1/8	5-1/4	4-1/4	7	13/32	12-3/16	24-3/4	12	247

MATERIAL SPECIFICATIONS

PART NAME	NICKEL ALUMINUM BRONZE	STAINLESS STEEL
Casing, Cover & Impeller	AMPCO® 483	316 Stainless
Wear Ring	AMPCO® 18	316 Stainless
Motor Shaft	Steel	Steel
Shaft Sleeve	AMPCO® 18	316 Stainless
Adapter	Cast Iron	Cast Iron

* Also available in Duplex 2205

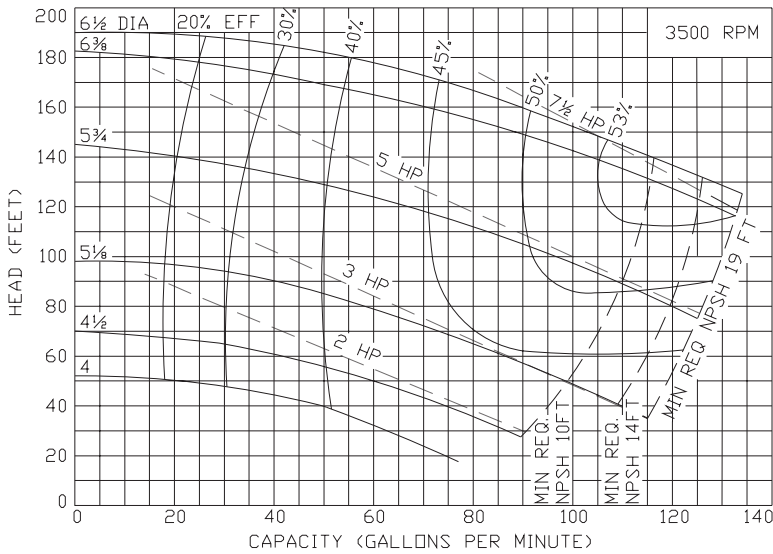

Ampco Centrifugal Pumps

MODEL KC2 2 X 1 1/2

Curves show approximate characteristics based on clear 68° water. Rated point is guaranteed.

Standard K Series pumps have threaded NPT connections. Models 1 1/2 x 1 1/4 and 2 x 1 1/2 are mounted on JM frame motors and offer the same hydraulic performance as the comparable Z Series pump

Seal options include Type 21, Type 1 and Type 9 with choice of sealing materials.

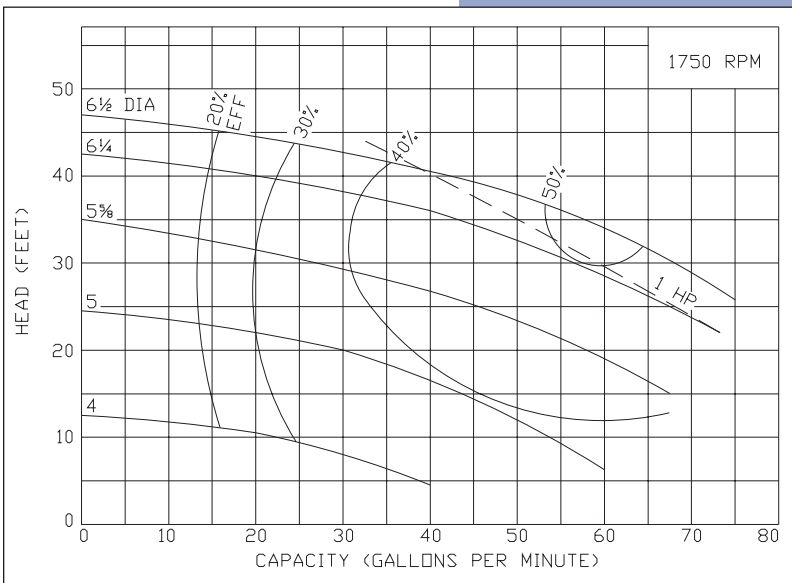
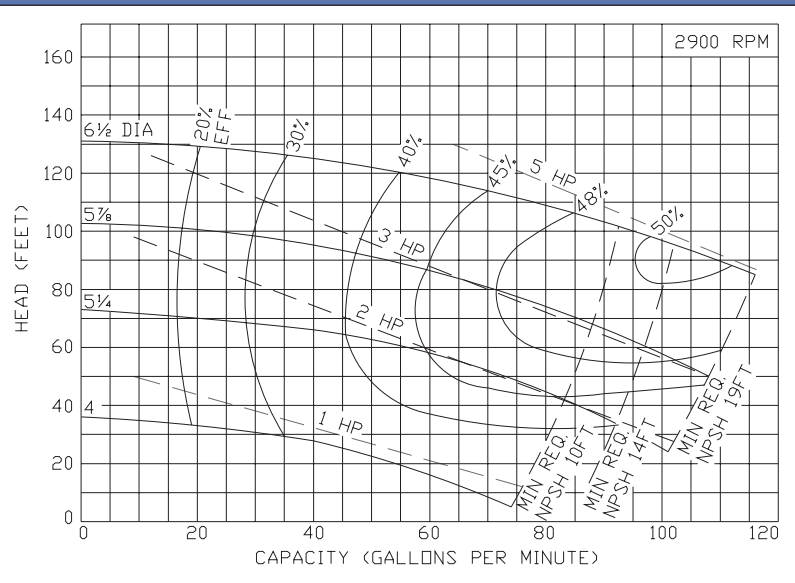

Ampco Pumps Company

4424 West Mitchell Street
 Milwaukee, Wisconsin 53214
 PHONE (414) 643-1852
 FAX (414) 643-4452

Ampco Centrifugal Pumps

DATA SHEET

MODEL KC2 2½X2

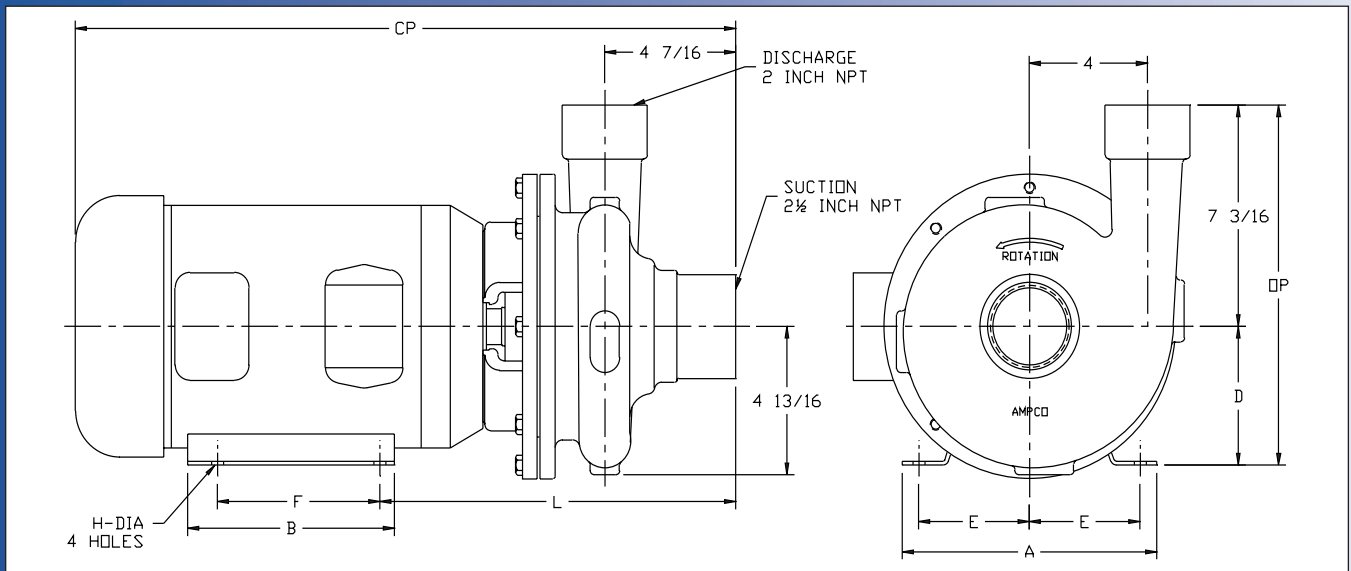
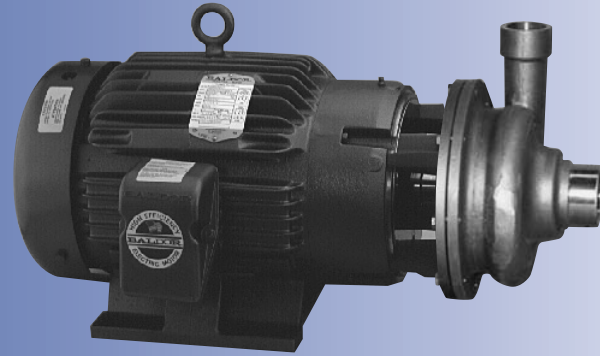

TEFC MOTOR			DIMENSIONS IN INCHES (For Reference Only)									APPROX. WEIGHT (LBS)
HP	RPM	FRAME	A (max)	B (max)	D	E	F	H	L	CP	OP	
1	1750	143JM	6-1/2	6	3-1/2	2-3/4	4	11/32	11-1/2	19-3/4	10-11/16	104
1-1/2	1750	145JM	6-1/2	6	3-1/2	2-3/4	5	11/32	11-1/2	19-3/4	10-11/16	108
2	1750	145JM	6-1/2	6	3-1/2	2-3/4	5	11/32	11-1/2	19-3/4	10-11/16	114
3	1750	182JM	8-5/8	6-1/2	4-1/2	3-3/4	4-1/2	13/32	12-1/8	21-1/8	11-11/16	140
5	3500	184JM	8-5/8	6-1/2	4-1/2	3-3/4	5-1/2	13/32	12-1/8	22-1/2	11-11/16	153
7-1/2	3500	213JM	9-5/8	8-1/8	5-1/4	4-1/4	5-1/2	13/32	13-1/8	25-3/8	12-7/16	121
10	3500	215JM	9-5/8	8-1/8	5-1/4	4-1/4	7	13/32	13-1/8	25-3/8	12-7/16	121
15	3500	215JM	9-5/8	8	5-1/4	4-1/4	7	13/32	13-1/8	25-1/4	12-7/16	263

MATERIAL SPECIFICATIONS

PART NAME	NICKEL ALUMINUM BRONZE	STAINLESS STEEL
Casing, Impeller & Cover	AMPCO® 483	316 Stainless Steel
Shaft Sleeve & Impeller Screw	AMPCO® 18	316 Stainless Steel
Motor Shaft	Steel	Steel
Adapter	Cast Iron	Cast Iron

* Also available in Duplex 2205

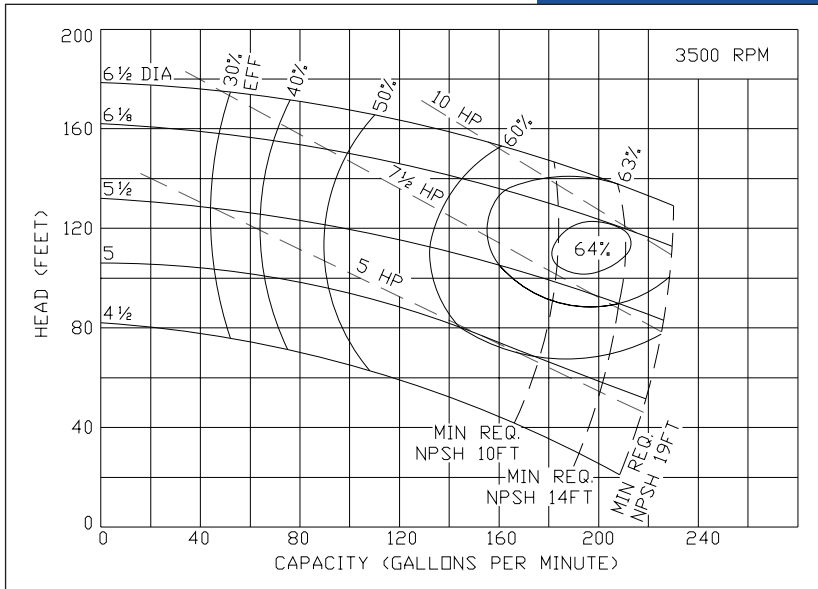

Ampco Centrifugal Pumps

MODEL KC2 2 1/2 X 2

Curves show approximate characteristics based on clear 68° water. Rated point is guaranteed.

Standard K Series pumps have threaded NPT connections. Models 1 1/2 x 1 1/4, 2 x 1 1/2 and 2 1/2 x 2 are mounted on JM frame motors and offer the same hydraulic performance as the comparable Z Series pump

Seal options include Type 21, Type 1 and Type 9 with choice of sealing materials.

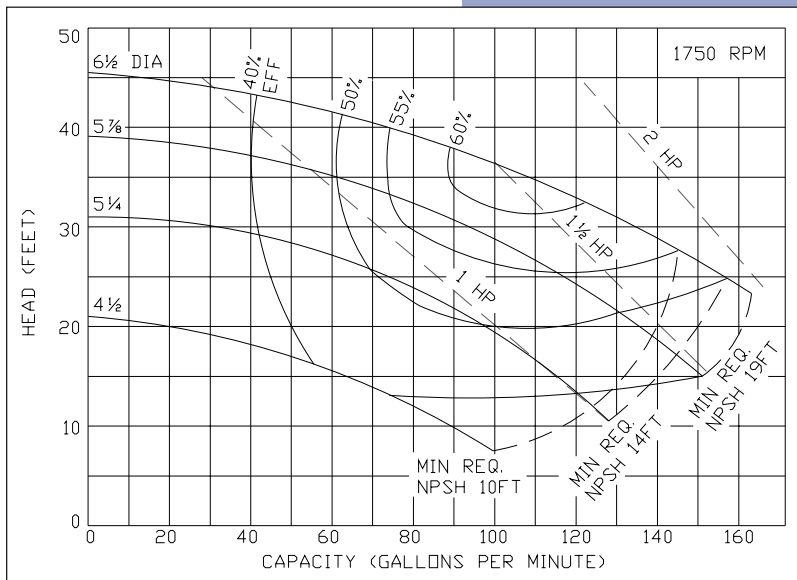
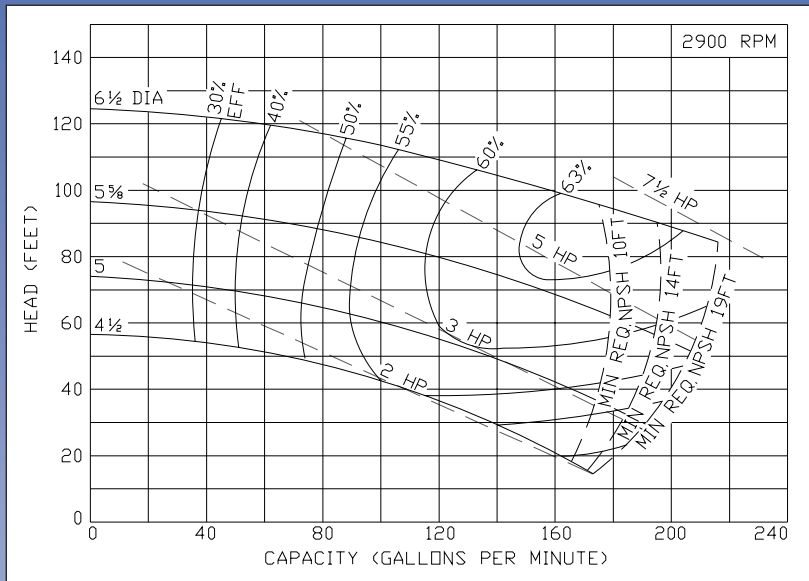

Ampco Pumps Company

4424 West Mitchell Street
 Milwaukee, Wisconsin 53214
 PHONE (414) 643-1852
 FAX (414) 643-4452

Ampco Centrifugal Pumps

DATA SHEET

MODEL KF 1/2 X 1/4
NICKEL ALUMINUM BRONZE

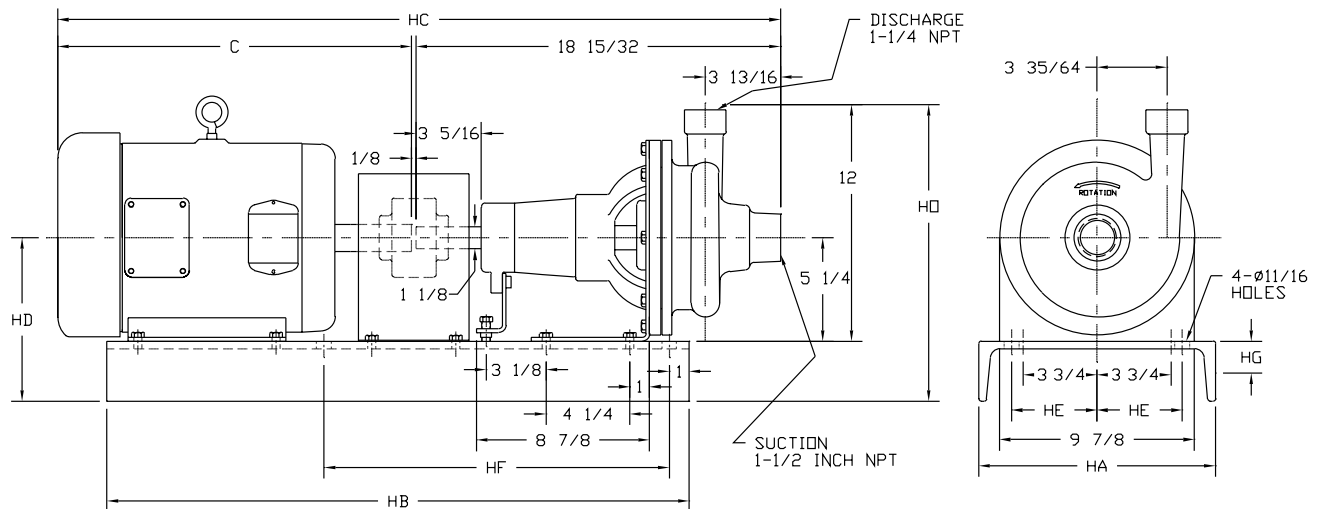
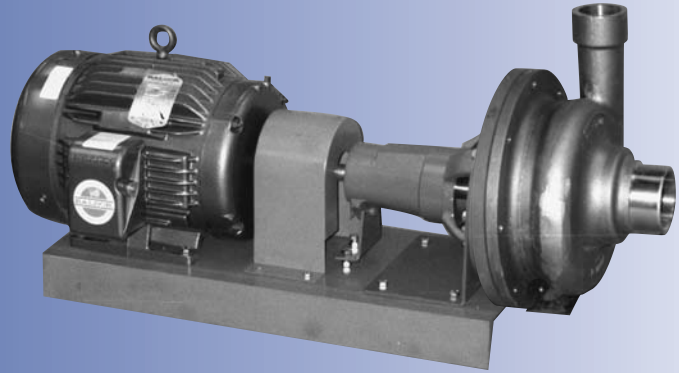

TEFC MOTOR			DIMENSIONS IN INCHES (For Reference Only)									
HP	RPM	FRAME	C	HA	HB	HC	HD	HE	HF	HG	HM	HO
1	1750	143T	13-1/16	10	26	31	7-7/8	3-3/4	24	2-5/8	11-3/4	14-3/8
2	3500	145T	13-1/16	10	26	31	7-7/8	3-3/4	24	2-5/8	11-3/4	14-3/8
3	3500	182T	15-3/8	10	26	33-5/16	7-7/8	3-3/4	16-1/4	2-5/8	12-1/2	14-3/8
5	3500	184T	15-3/8	10	26	33-5/16	7-7/8	3-3/4	16-1/4	2-5/8	12-1/2	14-3/8
7-1/2	3500	213T	19-7/16	12	28	37-3/8	8-1/4	4-1/2	17-1/2	3	13-3/4	14-3/4

MATERIAL SPECIFICATIONS

PART NAME	NICKEL ALUMINUM BRONZE
Casing, Cover & Impeller	AMPCO® 483
Wear Ring	AMPCO® 18
Shaft	Steel
Shaft Sleeve	AMPCO® 18
Frame	Cast Iron

Ampco Centrifugal Pumps

MODEL KF 1 1/2 X 1 1/4 NICKEL ALUMINUM BRONZE

Curves show approximate characteristics based on clear 68° water. Rated point is guaranteed.

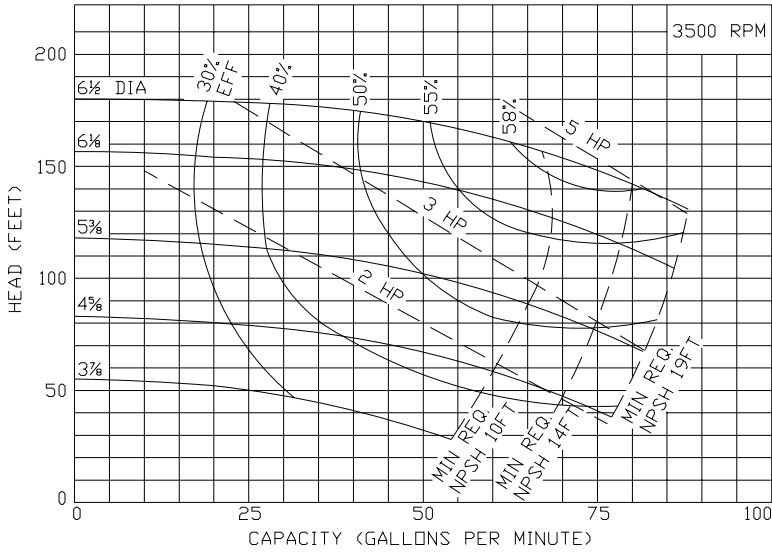

Standard K Series pumps have threaded NPT connections. Models 1 1/2 x 1 1/4 and 2 x 1 1/2 are mounted on JM frame motors and offer the same hydraulic performance as the comparable Z Series pump

Seal options include Type 21, Type 1 and Type 9 with choice of sealing materials.

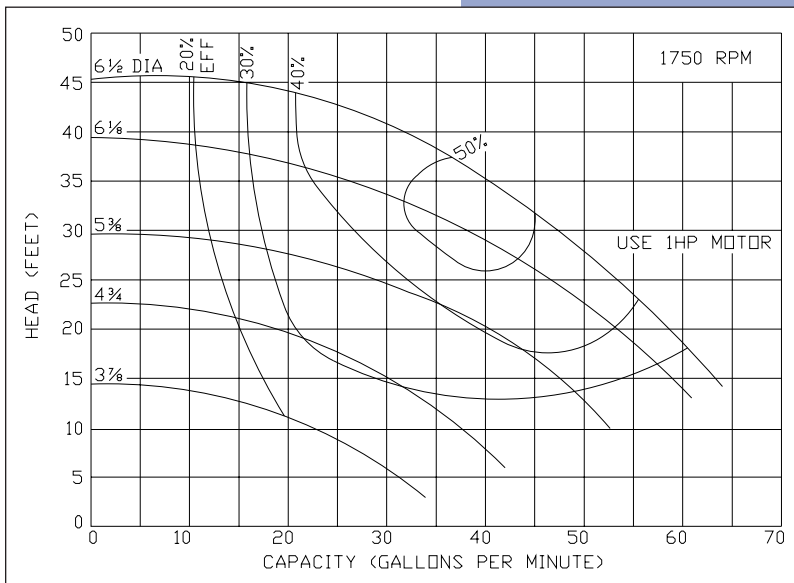
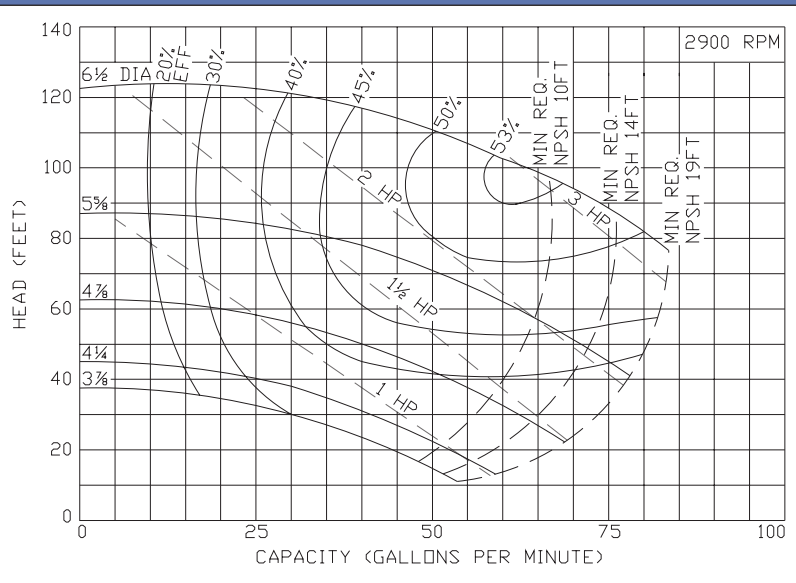

Ampco Pumps Company

4424 West Mitchell Street
Milwaukee, Wisconsin 53214
PHONE (414) 643-1852
FAX (414) 643-4452

Ampco Centrifugal Pumps

DATA SHEET

MODEL KF 1/2 X 1/4
STAINLESS STEEL

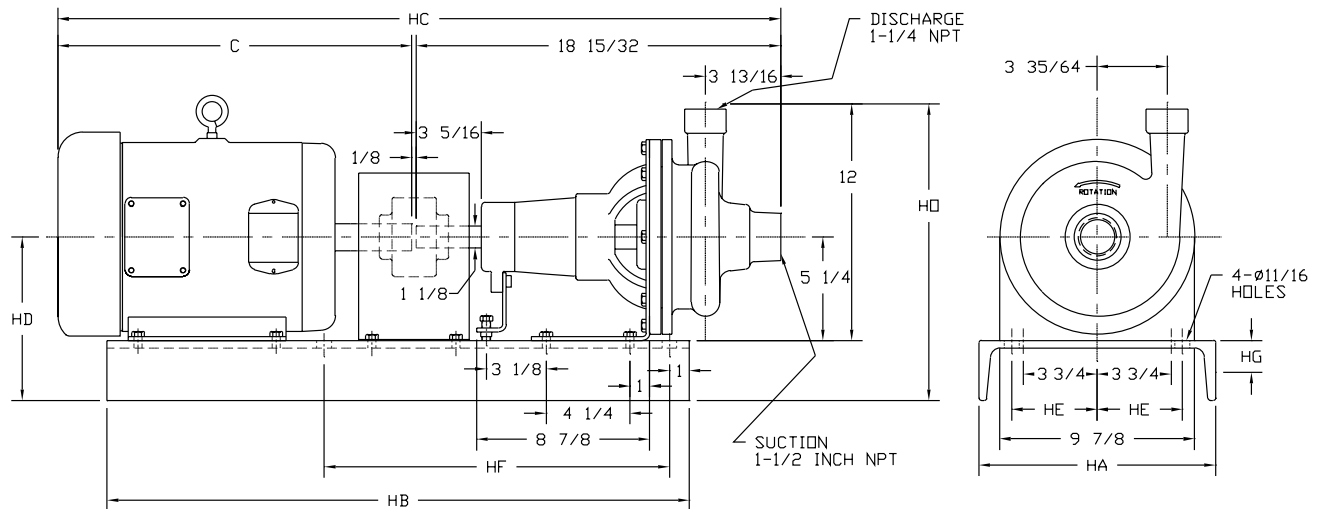
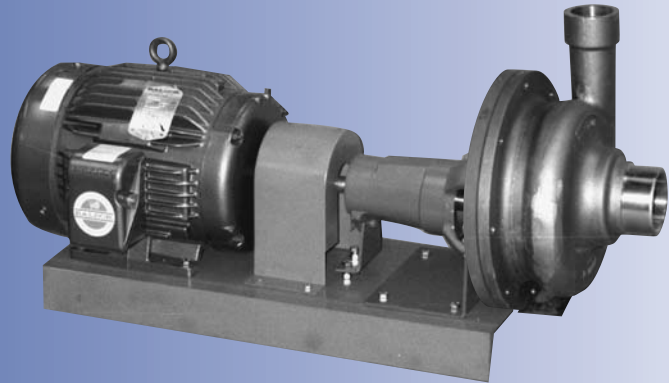

TEFC MOTOR			DIMENSIONS IN INCHES (For Reference Only)									
HP	RPM	FRAME	C	HA	HB	HC	HD	HE	HF	HG	HM	HO
1	1750	143T	13-1/16	10	26	31	7-7/8	3-3/4	24	2-5/8	11-3/4	14-3/8
2	3500	145T	13-1/16	10	26	31	7-7/8	3-3/4	24	2-5/8	11-3/4	14-3/8
3	3500	182T	15-3/8	10	26	33-5/16	7-7/8	3-3/4	16-1/4	2-5/8	12-1/2	14-3/8
5	3500	184T	15-3/8	10	26	33-5/16	7-7/8	3-3/4	16-1/4	2-5/8	12-1/2	14-3/8
7-1/2	3500	213T	19-7/16	12	28	37-3/8	8-1/4	4-1/2	17-1/2	3	13-3/4	14-3/4

MATERIAL SPECIFICATIONS

PART NAME	STAINLESS STEEL *
Casing, Cover & Impeller	316 Stainless
Wear Ring	316 Stainless
Shaft	Steel
Shaft Sleeve	316 Stainless
Frame	Cast Iron

* Also available in Duplex 2205

Ampco Centrifugal Pumps

MODEL KF 1½ X 1¼ STAINLESS STEEL

Curves show approximate characteristics based on clear 68° water. Rated point is guaranteed.

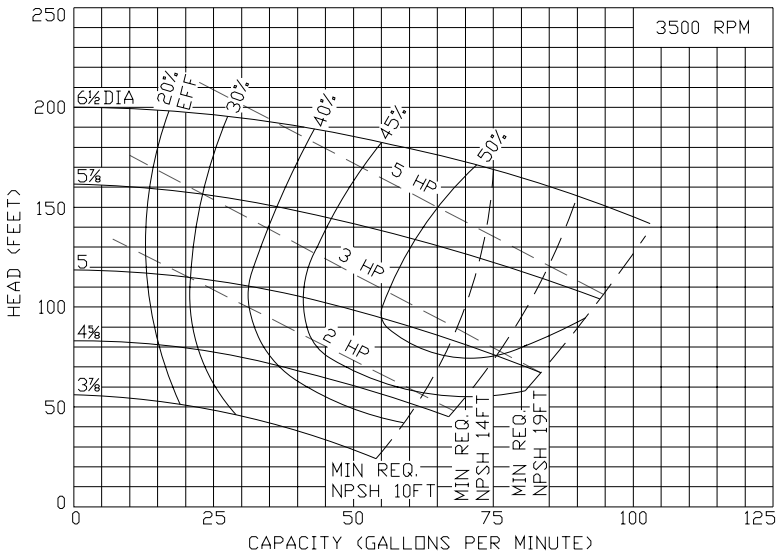

Standard K Series pumps have threaded NPT connections. Models 1½ x 1¼ and 2 x 1½ are mounted on JM frame motors and offer the same hydraulic performance as the comparable Z Series pump

Seal options include Type 21, Type 1 and Type 9 with choice of sealing materials.

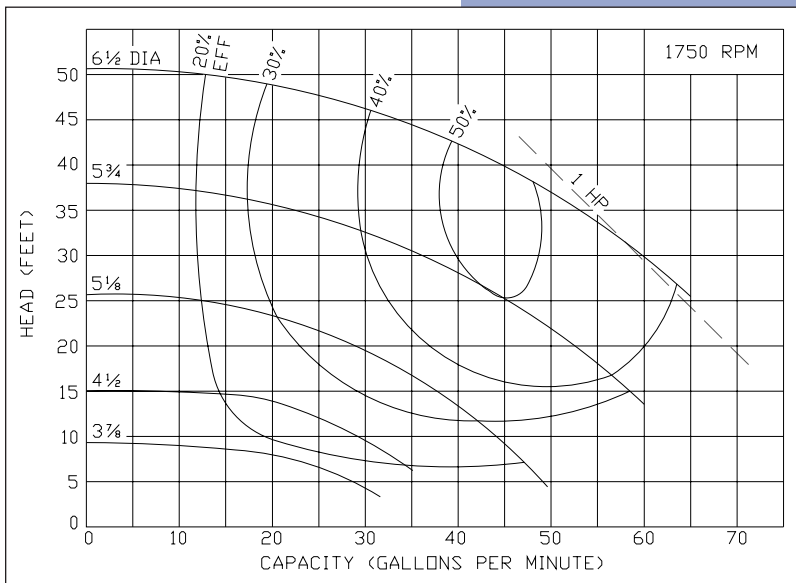
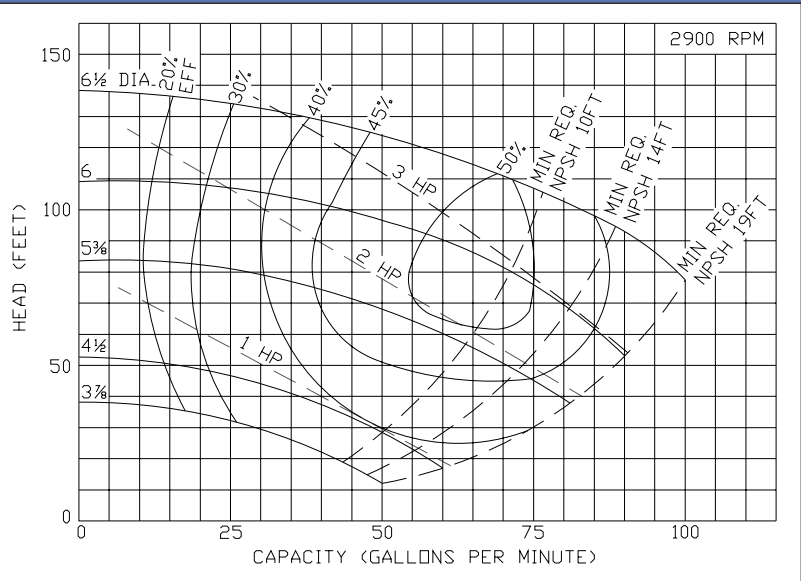

Ampco Pumps Company

4424 West Mitchell Street
Milwaukee, Wisconsin 53214
PHONE (414) 643-1852
FAX (414) 643-4452

Ampco Centrifugal Pumps

DATA SHEET

MODEL KF 2 X 1 1/2

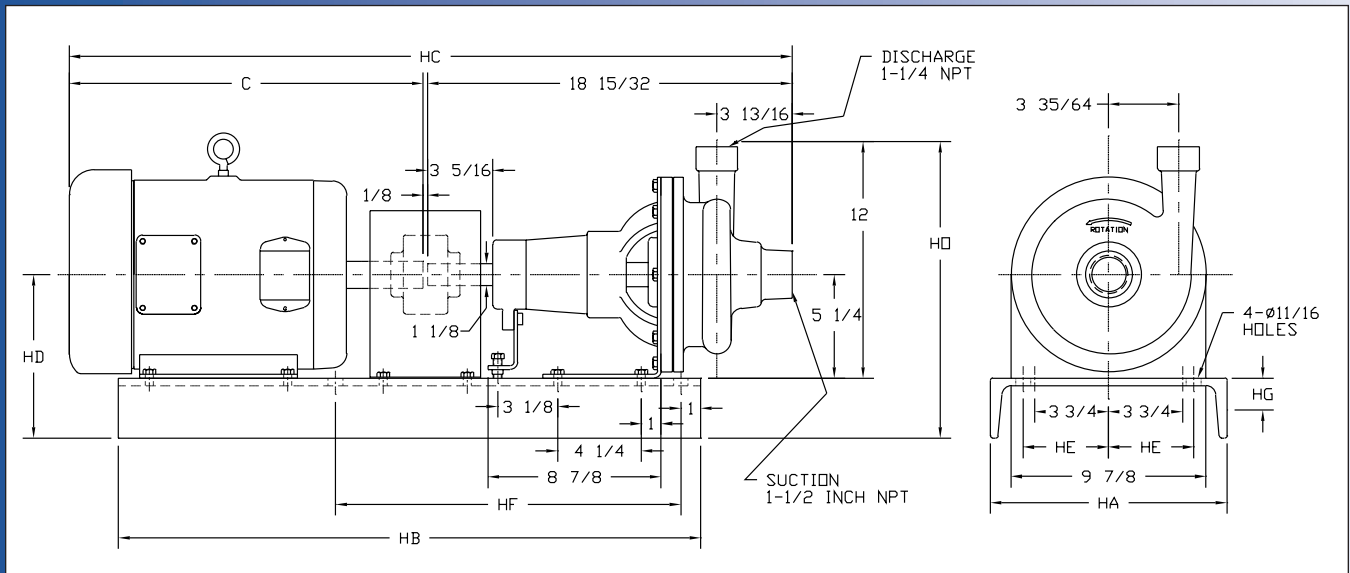
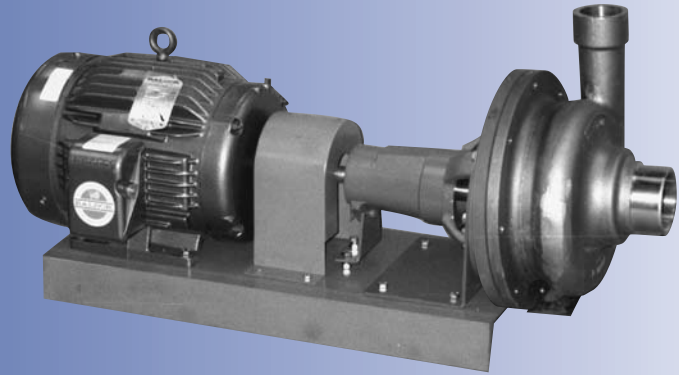

TEFC MOTOR			DIMENSIONS IN INCHES (For Reference Only)									
HP	RPM	FRAME	C	HA	HB	HC	HD	HE	HF	HG	HM	HO
1	1750	143T	13-1/16	10	26	30-15/16	7-7/8	3-3/4	24	2-5/8	11-3/4	14-5/8
2	3500	145T	13-1/16	10	26	30-15/16	7-7/8	3-3/4	24	2-5/8	11-3/4	14-3/8
3	3500	182T	15-3/8	10	26	33-1/4	7-7/8	3-3/4	16-1/4	2-5/8	12-1/2	14-3/8
5	3500	184T	15-3/8	10	26	33-1/4	7-7/8	3-3/4	16-1/4	2-5/8	12-1/2	14-3/8
7-1/2	3500	213T	19-7/16	12	28	37-5/16	8-1/4	4-1/2	17-1/2	3	13-3/4	15

MATERIAL SPECIFICATIONS

PART NAME	NICKEL ALUMINUM BRONZE	STAINLESS STEEL
Casing, Cover & Impeller	AMPCO® 483	316 Stainless
Wear Ring	AMPCO® 18	316 Stainless
Shaft	Steel	Steel
Shaft Sleeve	AMPCO® 18	316 Stainless
Frame	Cast Iron	Cast Iron

* Also available in Duplex 2205

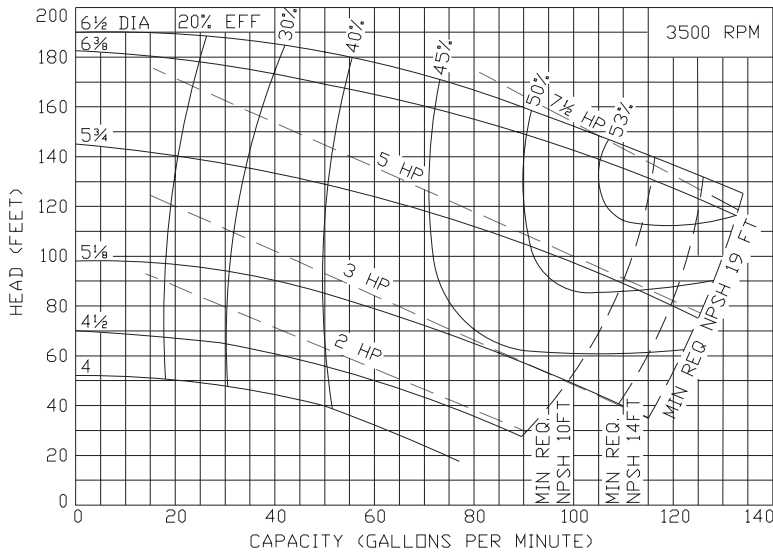

Ampco Centrifugal Pumps

MODEL KF 2 X 1 1/2

Curves show approximate characteristics based on clear 68° water. Rated point is guaranteed.

Standard K Series pumps have threaded NPT connections. Models 1 1/2 x 1 1/4 and 2 x 1 1/2 are mounted on JM frame motors and offer the same hydraulic performance as the comparable Z Series pump

Seal options include Type 21, Type 1 and Type 9 with choice of sealing materials.

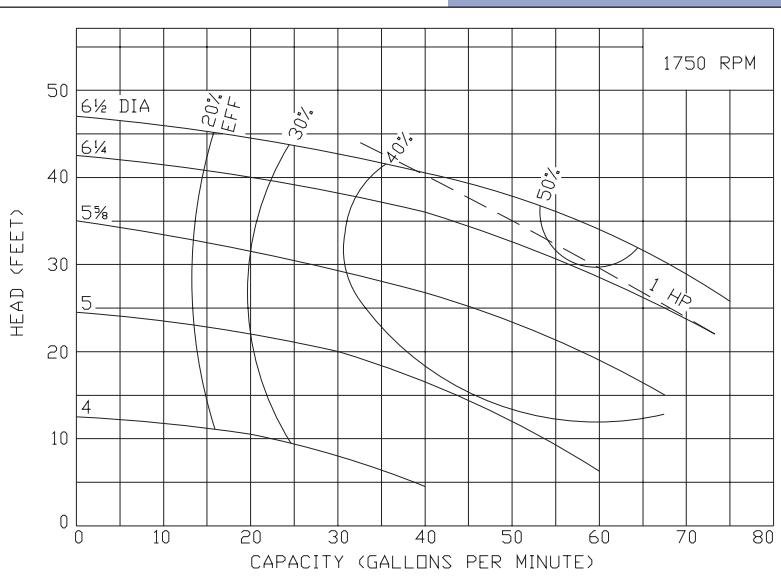
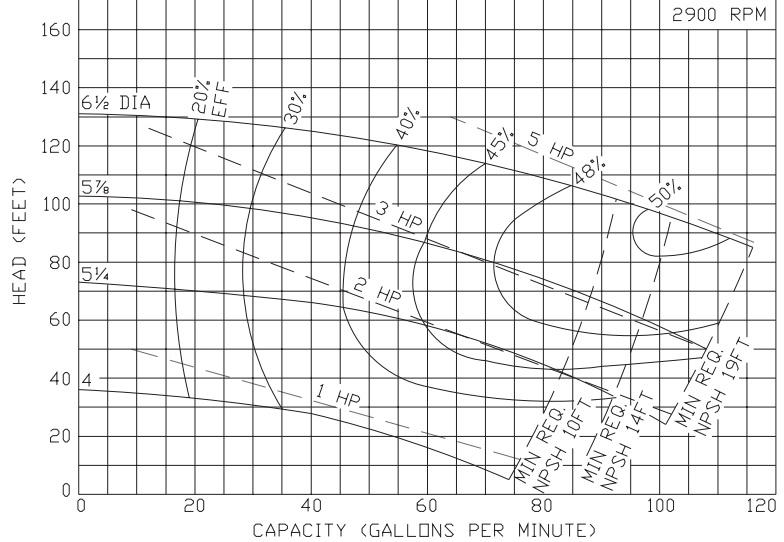

Ampco Pumps Company

4424 West Mitchell Street
 Milwaukee, Wisconsin 53214
 PHONE (414) 643-1852
 FAX (414) 643-4452

Ampco Centrifugal Pumps

DATA SHEET

MODEL KP 1X³/₄
NICKEL ALUMINUM BRONZE

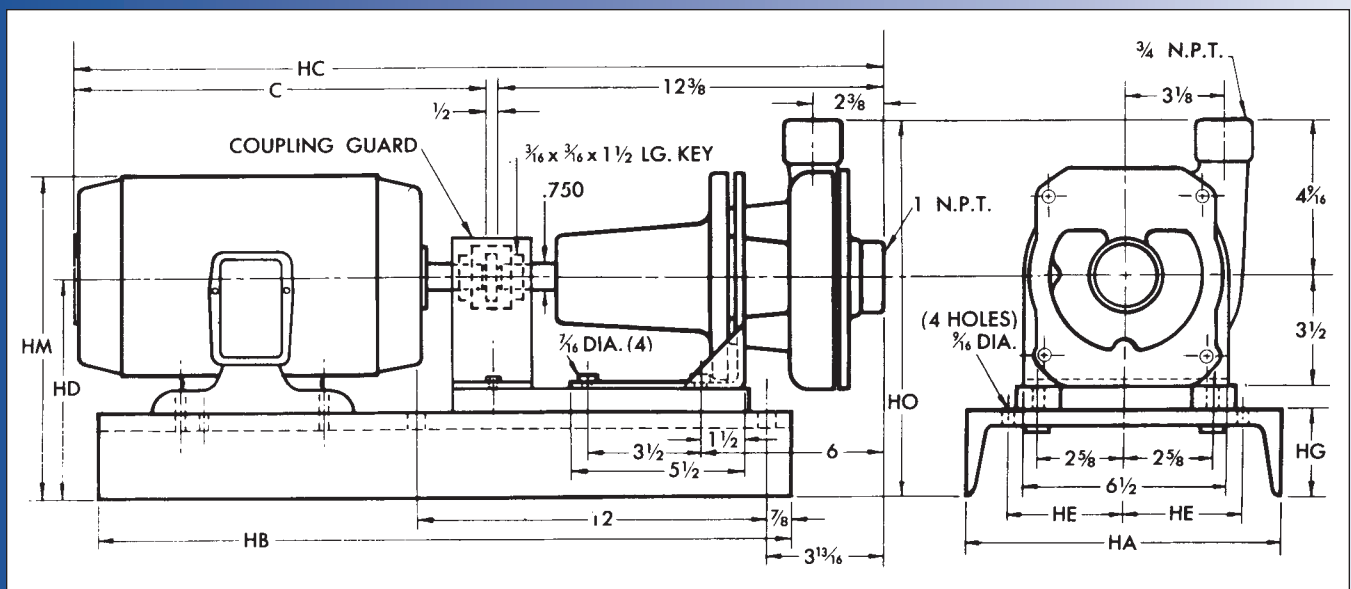
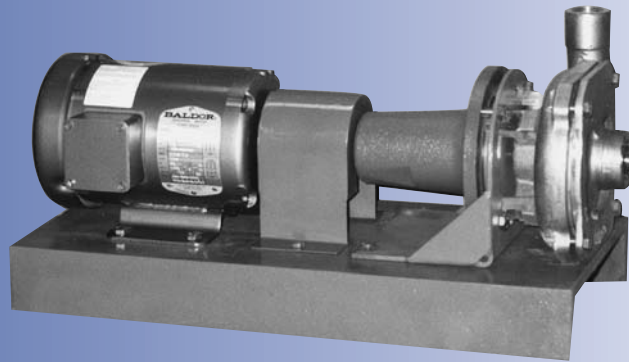

			DIMENSIONS IN INCHES (For Reference Only)								
TYPE	PUMP SIZE	FRAME SIZE	C	HA	HB	HC	HD	HE	HG	HM	HO
KP2	1 X 3/4	48	11-1/2	8	20	24-3/8	5-3/8	2-3/4	1-7/8	8-1/2	9-15/16
KP2	1 X 3/4	56 & 56H	12-1/2	8	20	25-3/8	5-3/8	2-3/4	1-7/8	8-31/32	9-15/16
KP2	1 X 3/4	56HZ, 143T, 145T	13-1/16	8	20	25-15/16	5-3/8	2-3/4	1-7/8	9-9/32	9-15/16
KP2	1 X 3/4	182T & 184T	15-3/8	10	22	28-1/4	7-1/8	3-3/4	2-5/8	11-3/4	11-11/16

MATERIAL SPECIFICATIONS

PART NAME	NICKEL ALUMINUM BRONZE
Casing	AMPCO® 483
Cover	AMPCO® 483
Impeller	AMPCO® 483
Shaft	Steel
Frame	Cast Iron

Ampco Centrifugal Pumps

**MODEL KP 1X^{3/4}
NICKEL ALUMINUM BRONZE**

Curves show approximate characteristics based on clear 68° water. Rated point is guaranteed.

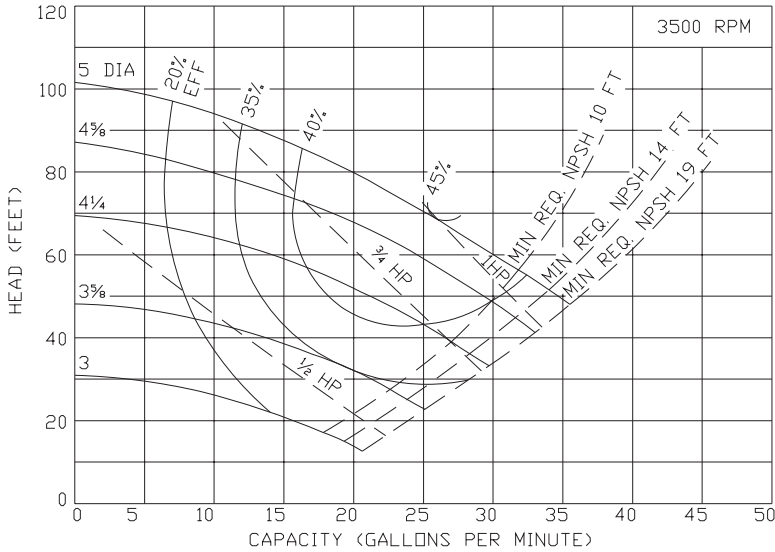

Standard K Series pumps have threaded NPT connections. Seal options include Type 21 and Type 9 with choice of sealing materials.

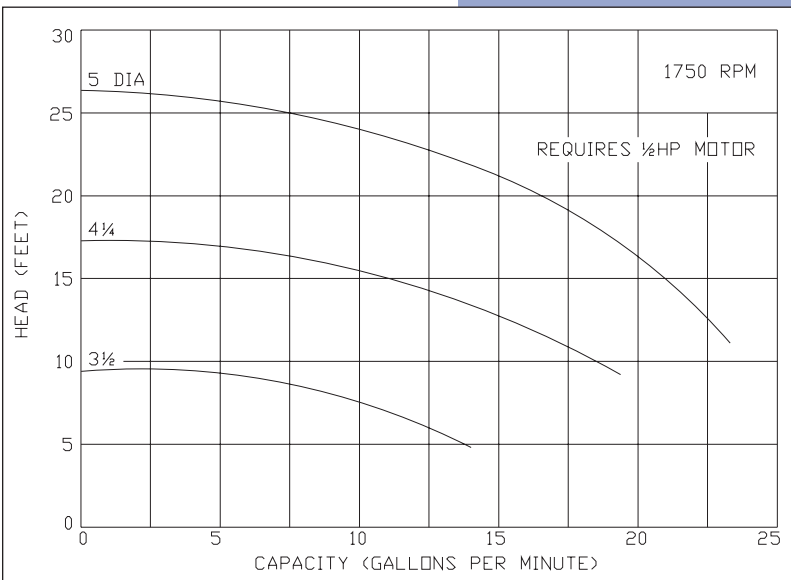
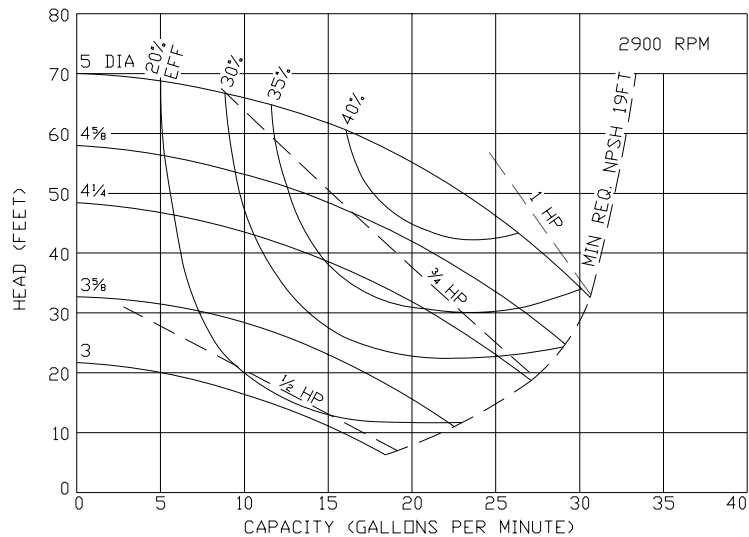

Ampco Pumps Company

4424 West Mitchell Street
Milwaukee, Wisconsin 53214
PHONE (414) 643-1852
FAX (414) 643-4452

Ampco Centrifugal Pumps

DATA SHEET

MODEL KP 1X^{3/4}
STAINLESS STEEL

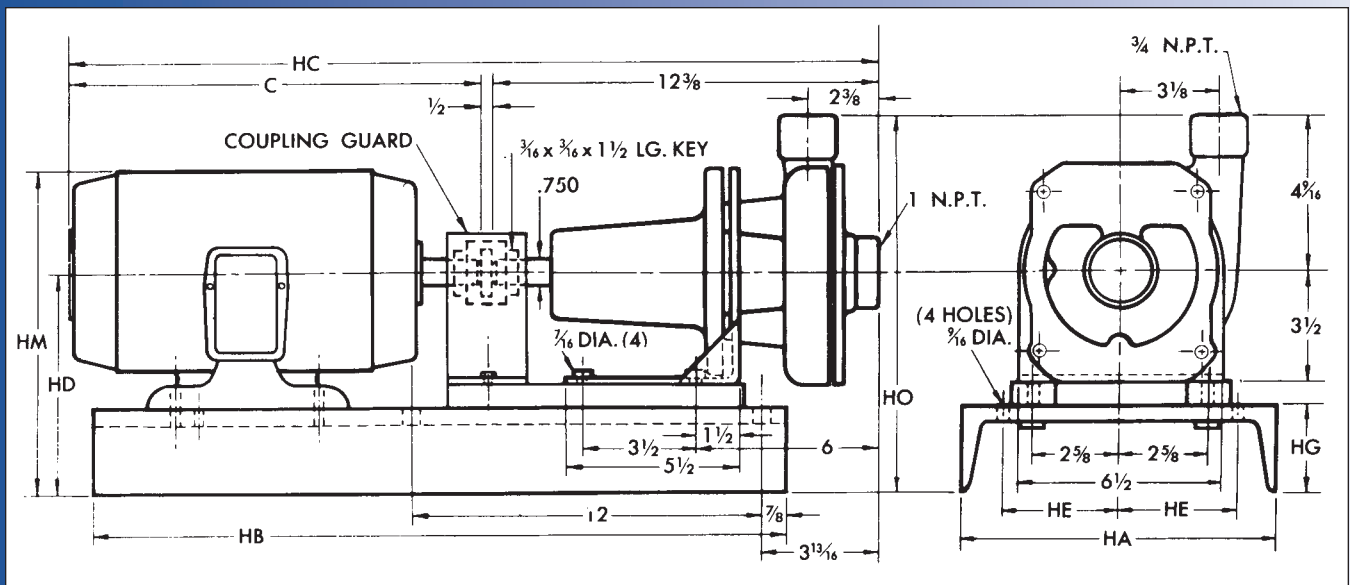
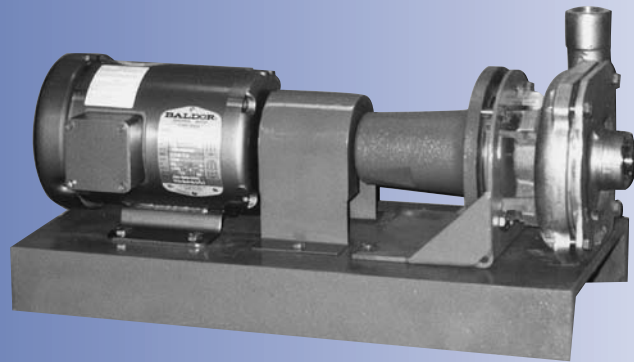

			DIMENSIONS IN INCHES (For Reference Only)								
TYPE	PUMP SIZE	FRAME SIZE	C	HA	HB	HC	HD	HE	HG	HM	HO
KP2	1 X 3/4	48	11-1/2	8	20	24-3/4	5-3/8	2-3/4	1-7/8	8-1/2	9-15/16
KP2	1 X 3/4	56 & 56H	12-1/2	8	20	25-3/8	5-3/8	2-3/4	1-7/8	8-31/32	9-15/16
KP2	1 X 3/4	56HZ, 143T, 145T	13-1/16	8	20	25-15/16	5-3/8	2-3/4	1-7/8	9-9/32	9-15/16
KP2	1 X 3/4	182T & 184T	15-3/8	10	22	28-1/4	7-1/8	3-3/4	2-5/8	11-3/4	11-11/16

MATERIAL SPECIFICATIONS

PART NAME	STAINLESS STEEL *
Casing & Cover	316 Stainless
Cover	316 Stainless
Impeller	316 Stainless
Shaft	Steel
Frame	Cast Iron

* Also available in Duplex 2205

Ampco Centrifugal Pumps

MODEL KP 1X^{3/4} STAINLESS STEEL

Curves show approximate characteristics based on clear 68° water. Rated point is guaranteed.

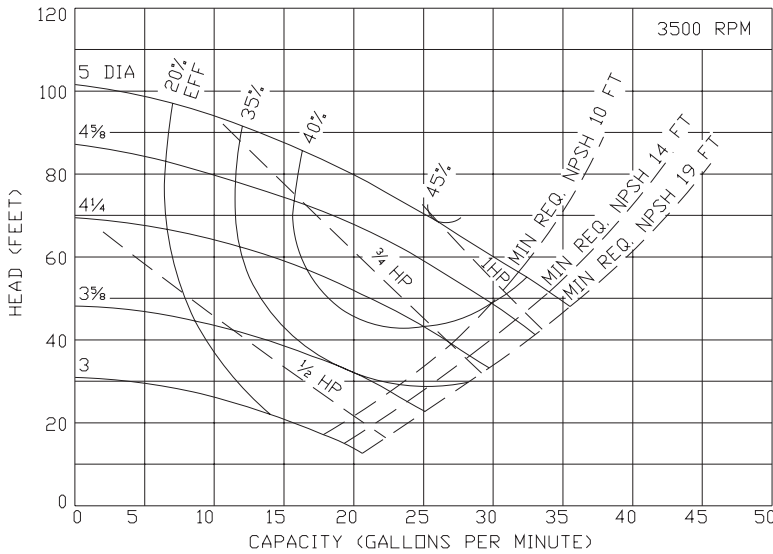

Standard K Series pumps have threaded NPT connections.

Seal options include Type 21 and Type 9 with choice of sealing materials.

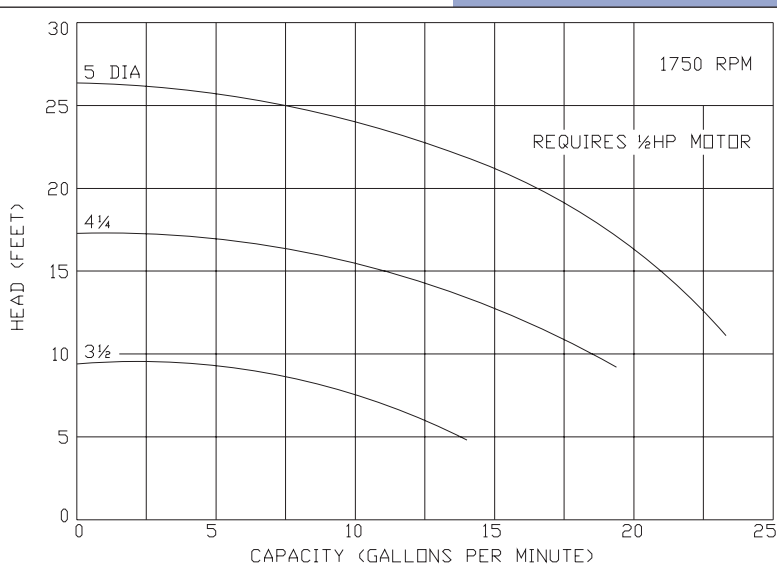
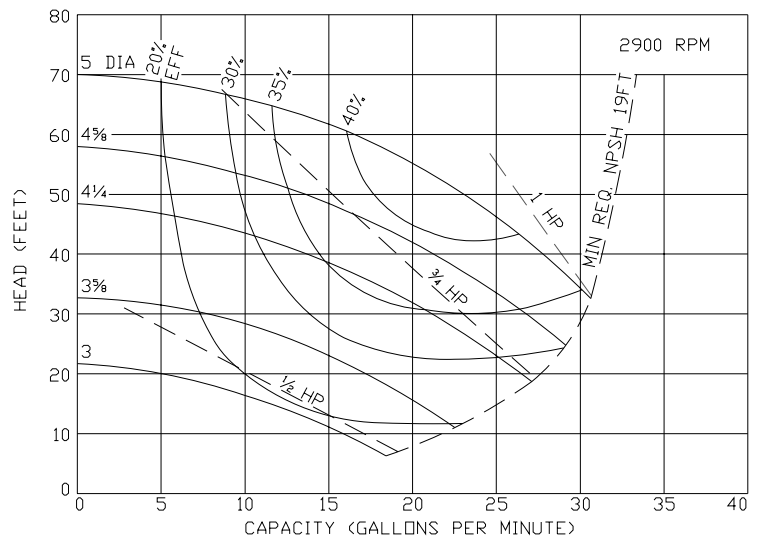

Ampco Pumps Company

4424 West Mitchell Street
Milwaukee, Wisconsin 53214
PHONE (414) 643-1852
FAX (414) 643-4452

Ampco Centrifugal Pumps

DATA SHEET

MODEL KP 1¹/₄ X 1

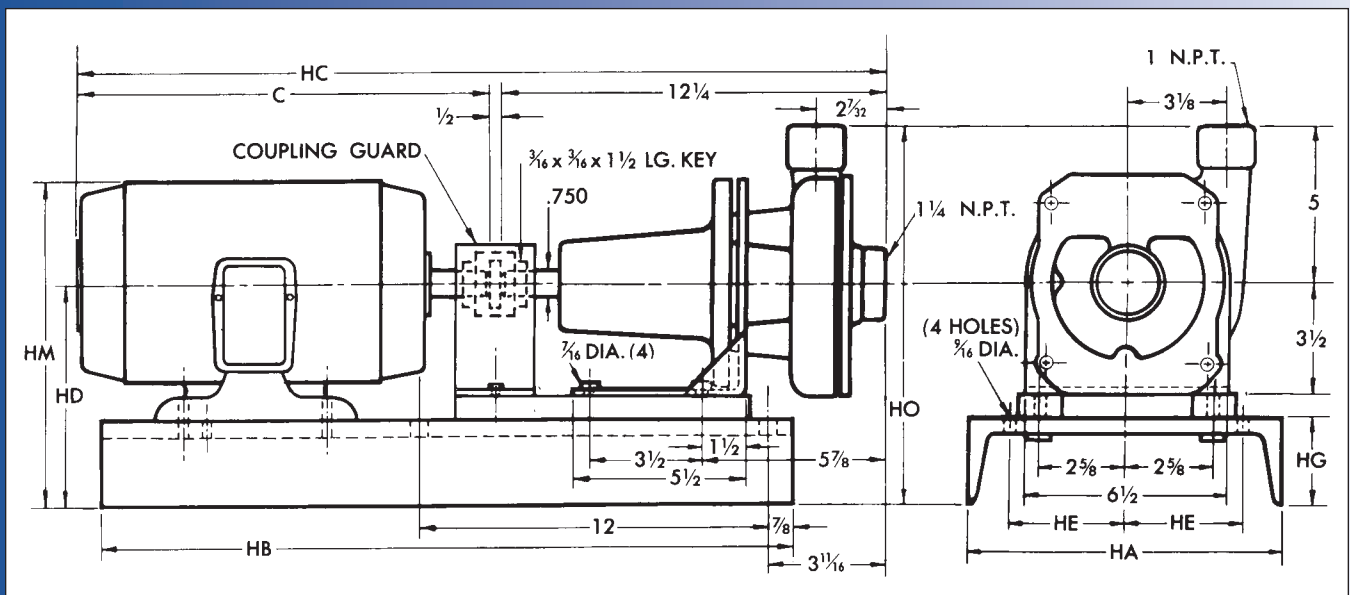
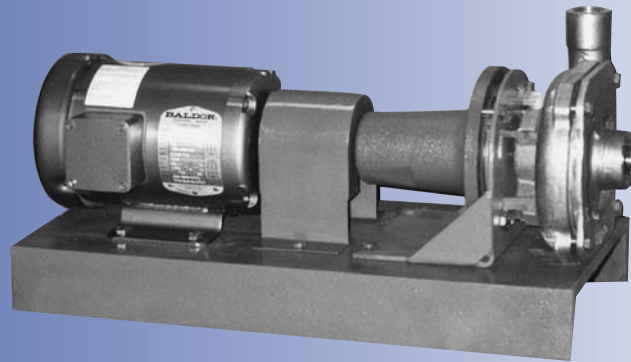

			DIMENSIONS IN INCHES (For Reference Only)								
TYPE	PUMP SIZE	FRAME SIZE	C	HA	HB	HC	HD	HE	HG	HM	HO
KP2	1-1/4 x 1	48	11-3/4	8	20	24-1/2	5-3/8	2-3/4	1-7/8	8-1/2	10-3/8
KP2	1-1/4 x 1	56 & 56H	12-1/2	8	20	25-1/4	5-3/8	2-3/4	1-7/8	8-21/32	10-3/8
KP2	1-1/4 x 1	56HZ, 143T, 145T	13-1/16	8	20	25-13/16	5-3/8	2-3/4	1-7/8	9-9/32	10-3/8
KP2	1-1/4 x 1	182T & 184T	15-3/8	10	22	28-1/8	7-1/8	3-3/4	2-5/8	11-3/4	12-1/8

MATERIAL SPECIFICATIONS

PART NAME	NICKEL ALUMINUM BRONZE	STAINLESS STEEL
Casing	AMPCO® 483	316 Stainless
Cover	AMPCO® 483	316 Stainless
Impeller	AMPCO® 483	316 Stainless
Shaft	Steel	Steel
Frame	Cast Iron	Cast Iron

* Also available in Duplex 2205

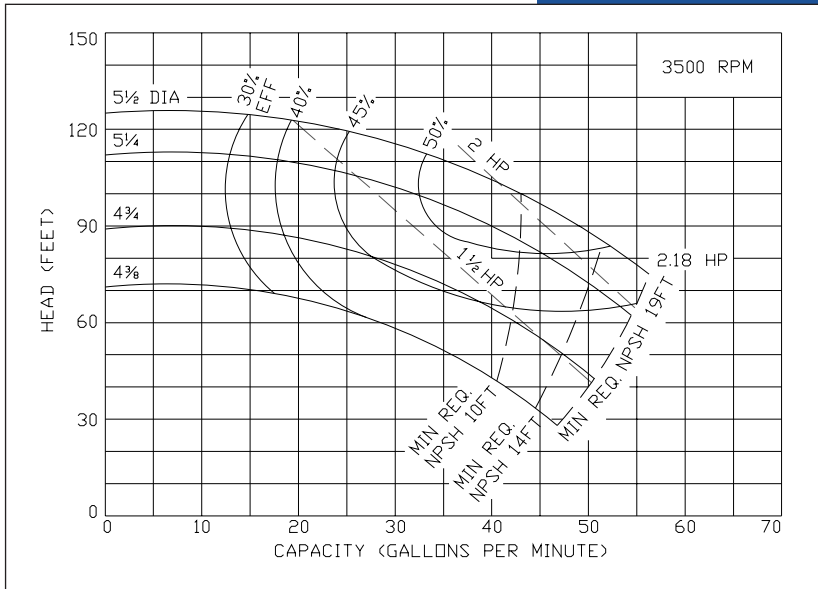

Ampco Centrifugal Pumps

MODEL KP 1 1/4 X 1

Curves show approximate characteristics based on clear 68° water. Rated point is guaranteed.

Standard K Series pumps have threaded NPT connections. Seal options include Type 21 and Type 9 with choice of sealing materials.

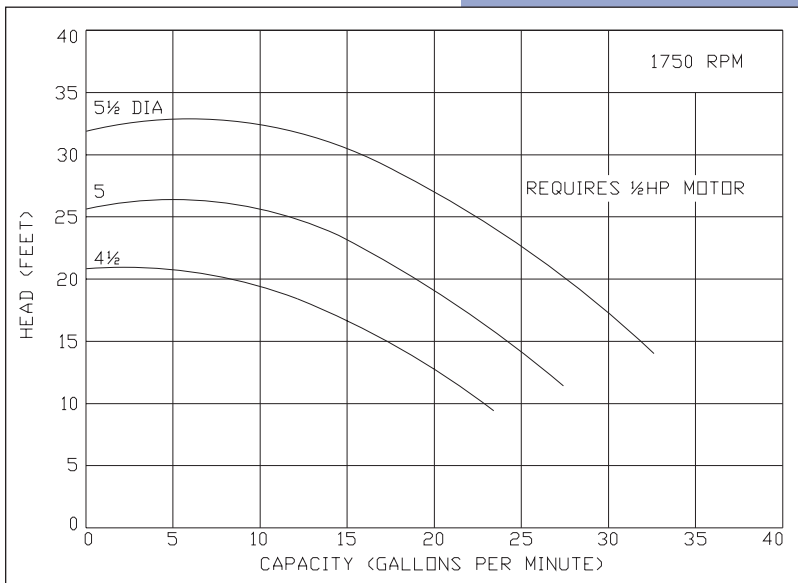
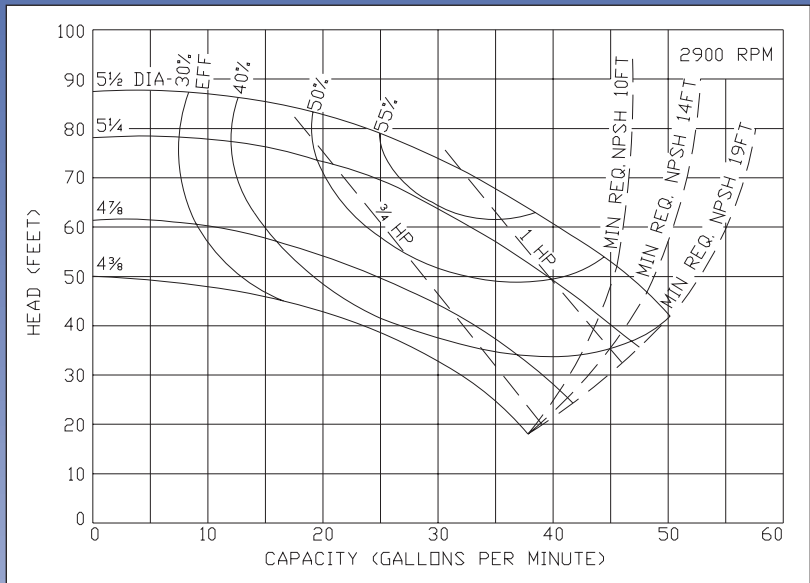

Ampco Pumps Company

4424 West Mitchell Street
 Milwaukee, Wisconsin 53214
 PHONE (414) 643-1852
 FAX (414) 643-4452

Ampco Centrifugal Pumps

DATA SHEET

MODEL KP 1 1/2 X 1

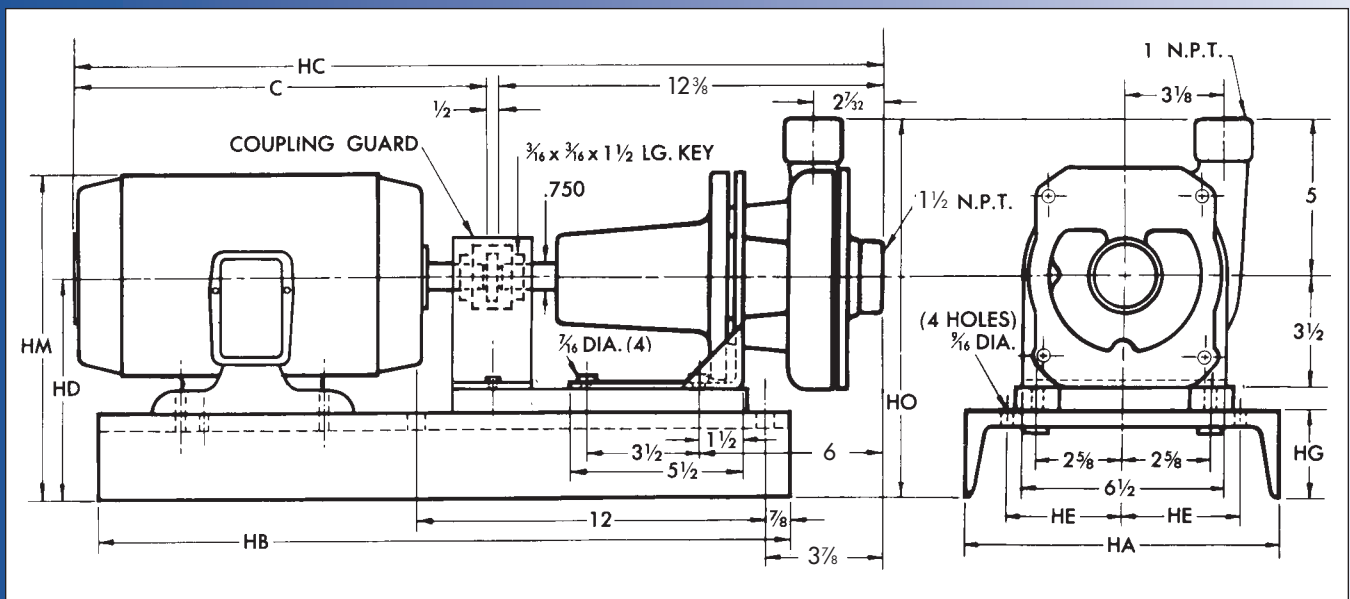
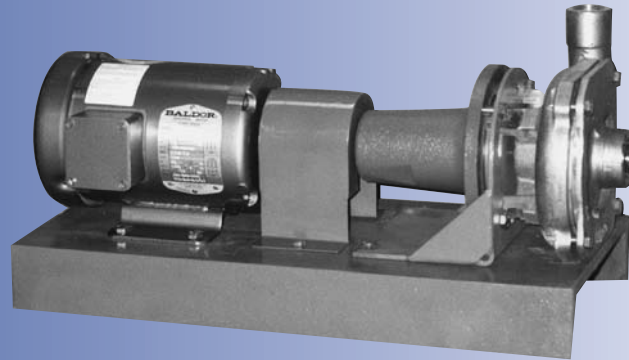

			DIMENSIONS IN INCHES (For Reference Only)								
TYPE	PUMP SIZE	FRAME SIZE	C	HA	HB	HC	HD	HE	HG	HM	HO
KP2	1-1/2 x 1	48	11-3/4	8	20	24-1/2	5-3/8	2-3/4	1-7/8	8-1/2	10-3/8
KP2	1-1/2 x 1	56 & 56H	12-1/2	8	20	25-1/4	5-3/8	2-3/4	1-7/8	8-21/32	10-3/8
KP2	1-1/2 x 1	56HZ, 143T, 145T	13-1/16	8	20	25-13/16	5-3/8	2-3/4	1-7/8	9-9/32	10-3/8
KP2	1-1/2 x 1	182T & 184T	15-3/8	10	22	28-1/8	7-1/8	3-3/4	2-5/8	11-3/4	12-1/8

MATERIAL SPECIFICATIONS

PART NAME	NICKEL ALUMINUM BRONZE	STAINLESS STEEL
Casing	AMPCO® 483	316 Stainless
Cover	AMPCO® 483	316 Stainless
Impeller	AMPCO® 483	316 Stainless
Shaft	Steel	Steel
Frame	Cast Iron	Cast Iron

* Also available in Duplex 2205

Ampco Centrifugal Pumps

MODEL KP 1 1/2 X 1

Curves show approximate characteristics based on clear 68° water. Rated point is guaranteed.

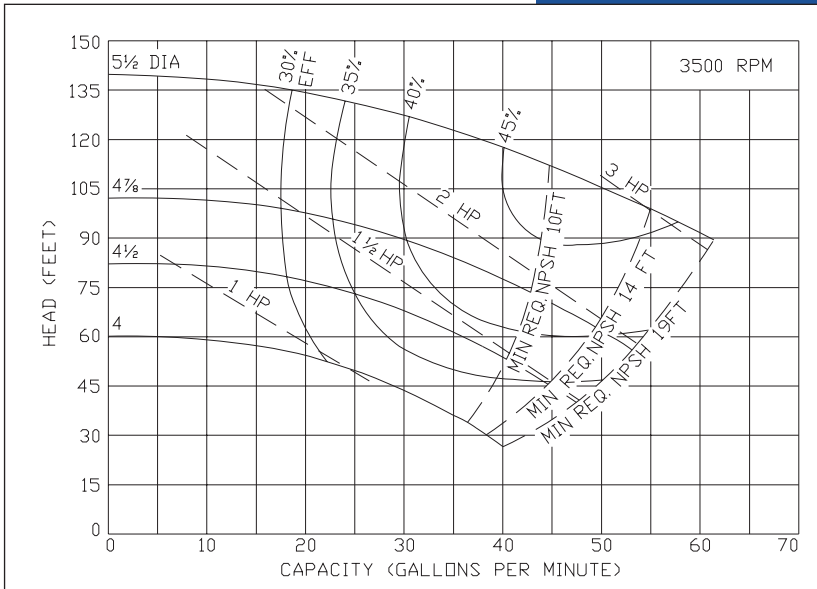

Standard K Series pumps have threaded NPT connections.

Seal options include Type 21 and Type 9 with choice of sealing materials.

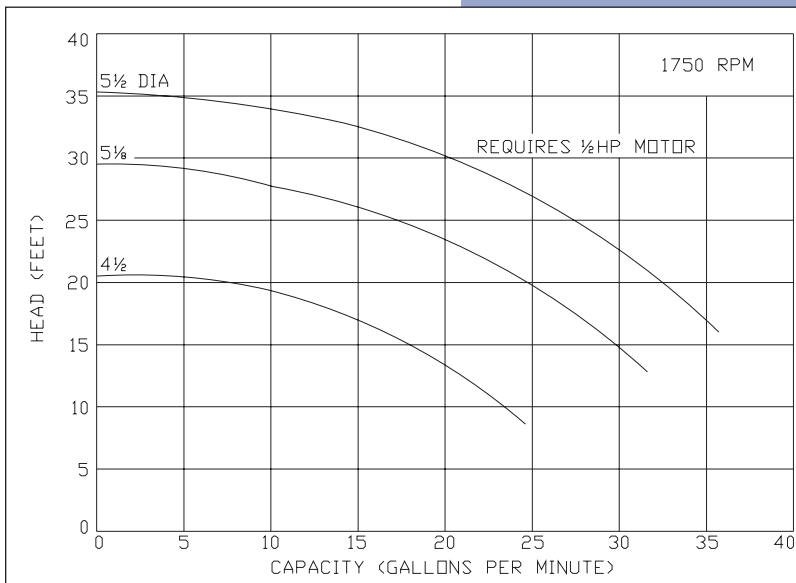
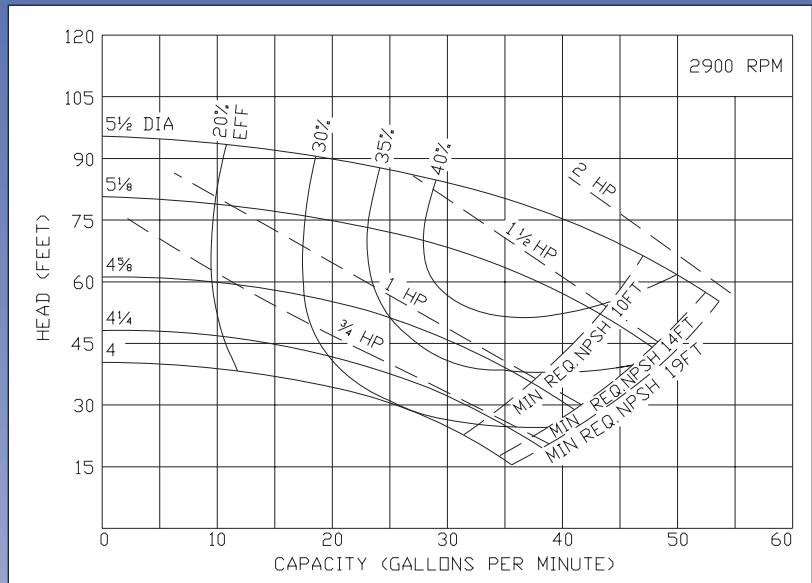

Ampco Pumps Company

4424 West Mitchell Street
 Milwaukee, Wisconsin 53214
 PHONE (414) 643-1852
 FAX (414) 643-4452