

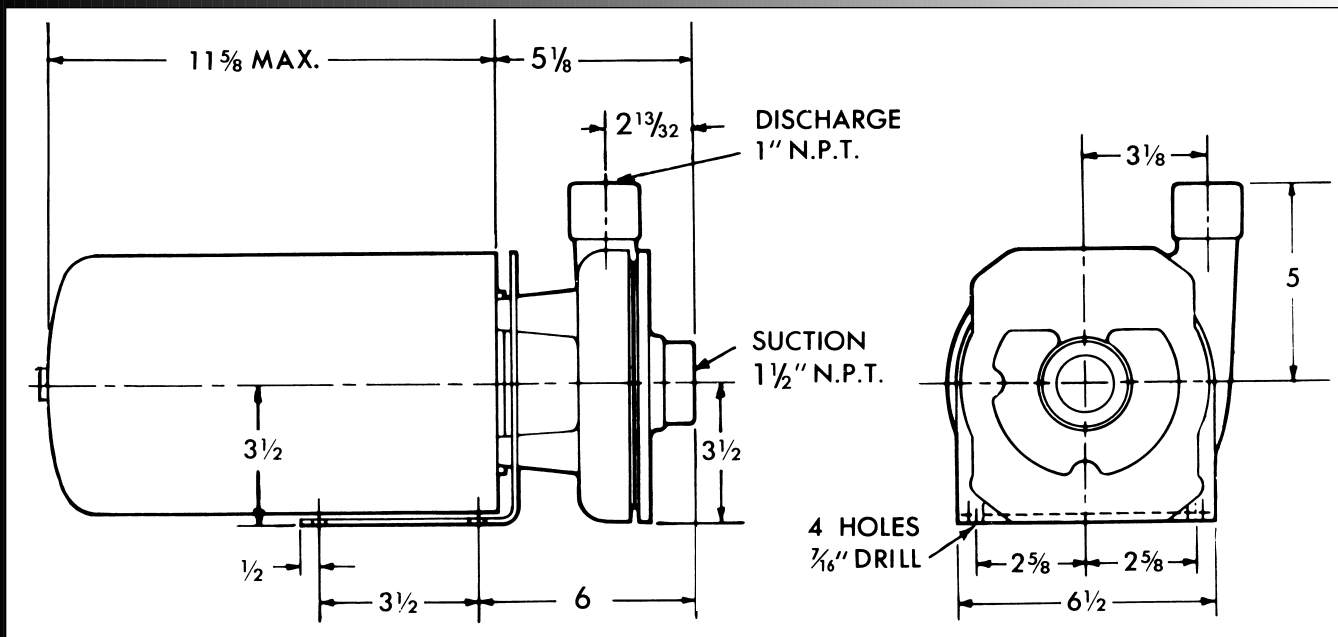

Ampco Centrifugal Pumps

Data Sheet

Model KC2 1 1/2 x 1



| HP | FRAME | APPROX. WEIGHT (LBS) |
|-----|-------|----------------------|
| 1/2 | 56J | 48 |
| 1 | 56J | 50 |
| 2 | 56J | 63 |
| 3 | 56J | 67 |

MATERIAL SPECIFICATIONS

| PART NAME | NICKEL ALUMINUM BRONZE | STAINLESS STEEL |
|-----------|------------------------|-----------------|
| Casing | AMPCO® 483 | 316 Stainless |
| Cover | AMPCO® 483 | 316 Stainless |
| Impeller | AMPCO® 483 | 316 Stainless |
| Bracket | Steel | Steel |

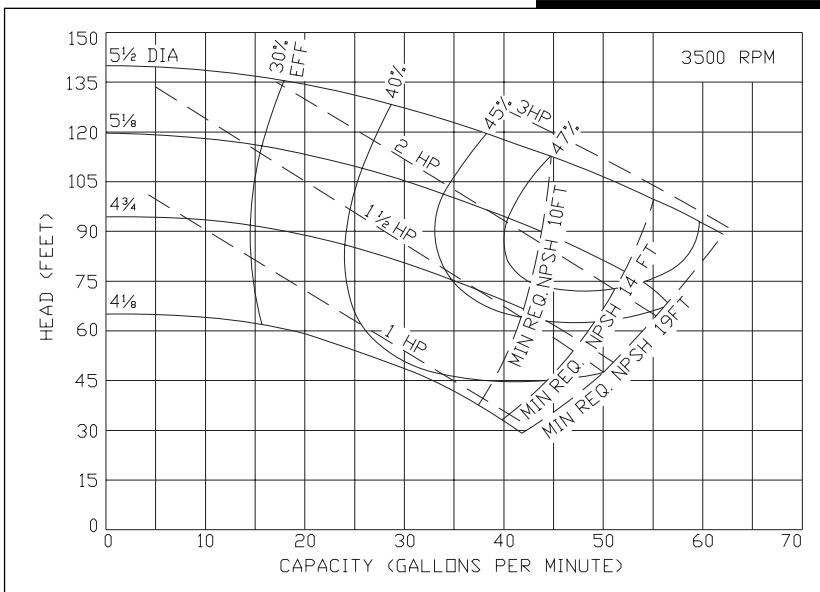

Ampco Centrifugal Pumps

Model KC2 1 1/2 x 1

Curves show approximate characteristics based on clear 68° water. Rated point is guaranteed.

Standard K Series pumps have threaded NPT connections and are mounted on 56J frame motors.

Seal options include Type 21 and Type 9 with choice of sealing materials.

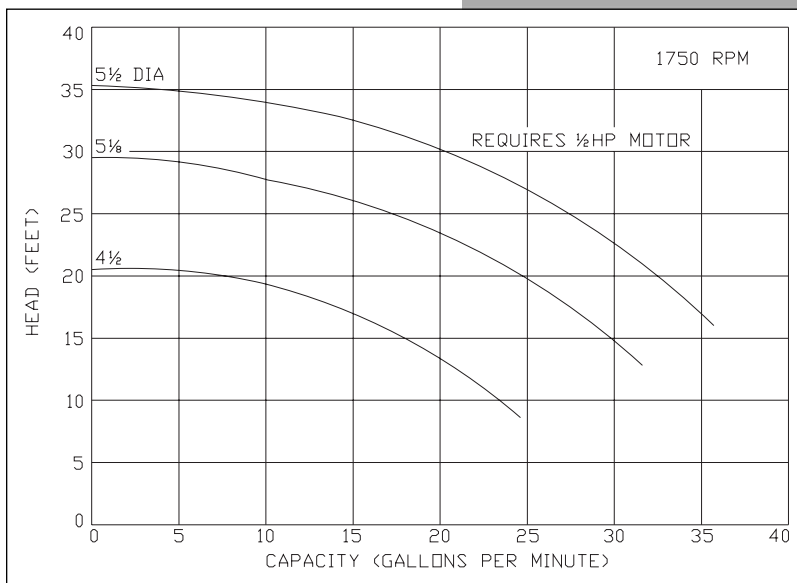
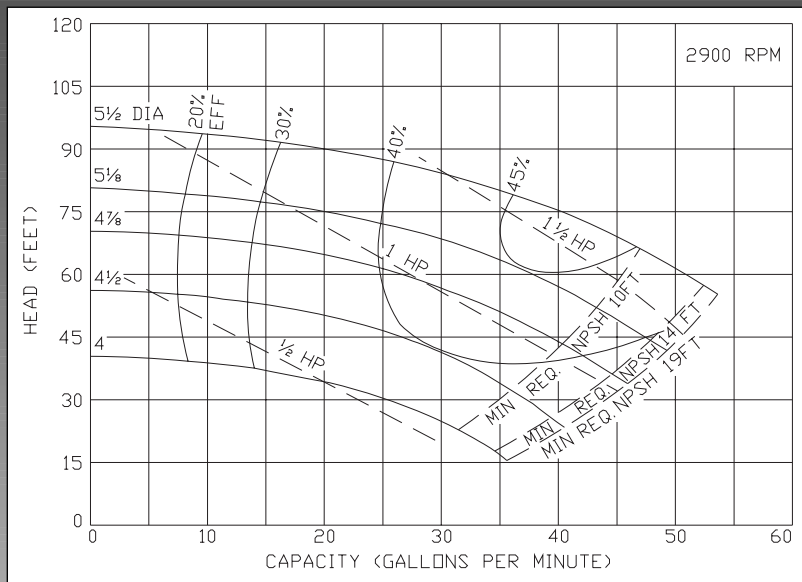

Ampco Pumps Company

4424 West Mitchell Street
 Milwaukee, Wisconsin 53214
 PHONE (414) 643-1852
 FAX (414) 643-4452