

Model SSV

Installation, Operation and Maintenance Instructions



Owner's Information

Pump Model Number: _____
 Pump Serial Number: _____
 Control Model Number: _____
 Dealer: _____
 Dealer Phone No.: _____
 Date of Purchase: _____ Installation: _____

Current Readings at Startup:

1 Ø	3 Ø	L1-2	L2-3	L3-1
Amps: _____	Amps: _____	_____	_____	_____
Volts: _____	Volts: _____	_____	_____	_____

SERIES/SÉRIE/SERIES

1SV	3SV	33SV	66SV
2SV	4SV	46SV	92SV

Table of Contents

SUBJECT	PAGE
SSV Product Line Numbering System	2
Safety Instructions	4
Overview.....	4
Product Description	4
Applications	4
Pre-Installation Checks.....	4
Transportation and Storage.....	5
Installation	6
Start-Up.....	8
Operation.....	9
Mechanical Seal Replacement.....	10
Motor Replacement.....	12
Troubleshooting	12
Engineering Data.....	12
Typical Plumbing and Installation	13
SSV Sectional Assembly	14
Limited Warranty	16

SSV PRODUCT LINE NUMBERING SYSTEM

The Model SSV embraces a line of stainless steel industrial, commercial and residential vertical, multistage, mechanical seal equipped pumps.

MODEL NOMENCLATURE (Sizes 1SV - 4SV)

1 SV A 1 C 1 B 0 H

◀ EXAMPLE PRODUCT CODE

H = Horizontal Mount VIC = Victaulic Connection

Mechanical Seal Options:

Code No.	Rotary	Stationary	Elastomers	Reference Application	Replacement Mechanical Seal Part Number	
					1SV/ 2SV	3SV/ 4SV
0	High Temp Carbon	Silicon Carbide (Graphite filled)	Viton	General Service	10K93	10K94
4	Silicon Carbide			Abrasive	10K99	10K100
6	High Temp Carbon		EPR	Boiler Feed	10K96	10K97

Metal parts on all seals are 316SS. When reordering units with previous seal options 2, 3 or 5 review application and order new seal option from above chart.

Number of Stages:

B = 2 F = 6 K = 11 P = 14 V = 20
 C = 3 G = 7 L = 12 Q = 15 X = 22
 D = 4 H = 8 M = 12 R = 16 z = 24
 E = 5 J = 9 N = 13 T = 18

Motor Phase and Enclosure:

0 = 1PH XP 4 = 1PH TEFC 8 = 575V XP
 1 = 1PH ODP 5 = 3PH TEFC 9 = 3PH TEFC
 2 = 3PH ODP 6 = 575V TEFC with premium efficiency
 3 = 575V ODP 7 = 3PH XP

Motor HP:

C = 1/2 F = 1 1/2 J = 5 M = 15 Q = 30
 D = 3/4 G = 2 K = 7 1/2 N = 20
 E = 1 H = 3 L = 10 P = 25

Motor Hertz/RPM:

1 = 60 Hz/3450 RPM
 2 = 50 Hz/2900 RPM

Pump Material and Suction/Discharge Style:

A = 304 SS, Inline NPT Oval Flange (1-3SV only)
 B = 304 SS, Inline ANSI
 C = 304 SS, Top/Bottom ANSI
 D = 316 SS, Inline ANSI

Series: Stainless Steel Vertical

Nominal Pump Performance:

1 = 15 GPM 3 = 55 GPM
 2 = 28 GPM 4 = 86 GPM

Always specify the unit model and catalog number from pump nameplate when service or technical assistance is required.

NOTICE: INSPECT UNIT FOR DAMAGE AND REPORT ALL DAMAGE TO THE CARRIER OR DISTRIBUTOR/DEALER IMMEDIATELY.

SSV PRODUCT LINE NUMBERING SYSTEM

MODEL NOMENCLATURE (Sizes 33SV - 92SV)

33 SV B G 1 2 N 6 T A

◀ EXAMPLE PRODUCT CODE

Seal Options:

- A = Carbide/Silicon Carbide/Viton
- B = Carbide/Silicon Carbide/EPDM
- C = Silicon Carbide/Silicon Carbide/Viton
- D = Silicon Carbide/Silicon Carbide/EPDM

- L = Cartridge - Carbide/Silicon Carbide/Viton
- P = Cartridge - Silicon Carbide/Silicon Carbide/EPDM

Motor Enclosure:

- D = ODP
- T = TEFC
- E = ODP, Premium Effy
- P = TEFC, Premium Effy
- X = Explosion Proof

Motor Voltage:

- 1 = 115/230
- 2 = 230
- 3 = 230/460
- 4 = 460
- 5 = 575
- 6 = 208-230/460

Motor HP:

- G = 2 K = 7½ N = 20 R = 40 U = 75
- H = 3 L = 10 P = 25 S = 50
- J = 5 M = 15 Q = 30 T = 60

Motor Hertz/Speed/Phase:

- 1 = 60 Hz/3500 RPM/1Ø 4 = 60 Hz/1750 RPM/3Ø 7 = 50 Hz/1450 RPM/1Ø
- 2 = 60 Hz/3500 RPM/3Ø 5 = 50 Hz/2900 RPM/1Ø 8 = 50 Hz/1450 RPM/3Ø
- 3 = 60 Hz/1750 RPM/1Ø 6 = 50 Hz/2900 RPM/3Ø 9 = 60 Hz/Variable/3Ø

Reduced Impellers: Number of reduced Diameter Impellers (can be 0).

Bowls/Stages:

- A = 1 E = 5 J = 9
- B = 2 F = 6 K = 10
- C = 3 G = 7
- D = 4 H = 8

Flange Orientation:

- B = CI/316 SS, Round ANSI Flanges
- D = 316 SS, Round ANSI Flanges

Product Line: Stainless Vertical Multistage

Nominal Flow:

- 33 = 150 GPM 66 = 350 GPM
- 46 = 225 GPM 92 = 450 GPM

SAFETY INSTRUCTIONS

TO AVOID SERIOUS OR FATAL PERSONAL INJURY OR MAJOR PROPERTY DAMAGE, READ AND FOLLOW ALL SAFETY INSTRUCTIONS IN MANUAL AND ON PUMP.

THIS MANUAL IS INTENDED TO ASSIST IN THE INSTALLATION AND OPERATION OF THIS UNIT AND MUST BE KEPT WITH THE PUMP.



This is a **SAFETY ALERT SYMBOL**. When you see this symbol on the pump or in the manual, look for one of the following signal words and be alert to the potential for personal injury or property damage.



DANGER Warns of hazards that **WILL** cause serious personal injury, death or major property damage.



WARNING Warns of hazards that **CAN** cause serious personal injury, death or major property damage.



CAUTION Warns of hazards that **CAN** cause personal injury or property damage.

NOTICE: INDICATES SPECIAL INSTRUCTIONS WHICH ARE VERY IMPORTANT AND MUST BE FOLLOWED.

THOROUGHLY REVIEW ALL INSTRUCTIONS AND WARNINGS PRIOR TO PERFORMING ANY WORK ON THIS PUMP.

MAINTAIN ALL SAFETY DECALS.



UNIT NOT DESIGNED FOR USE WITH HAZARDOUS LIQUIDS OR FLAMMABLE GASES. THESE FLUIDS MAY BE PRESENT IN CONTAINMENT AREAS.



Hazardous fluids can cause fire, burns or death.

OVERVIEW

The purpose of this manual is to provide the necessary information for proper installation, operation and maintenance of the SSV pump. The instructions and warnings provided below concern the standard version, as described in the sale documents. Special versions may be supplied with supplementary instructions leaflets. Please refer to the sale contract for any modifications or special version characteristics. Always specify the exact pump type and identification code when requesting technical information or spare parts from our Sales and Service department. For instructions, situations or events not considered in this manual or in the sale documents, please contact your distributor.

Read this manual before installing and using the product.



Improper use may cause personal injury and damage to property and lead to the forfeiture of the warranty coverage.

PRODUCT DESCRIPTION

The SSV pump is a vertical multistage, non-self priming pump which can be coupled to standard electric motors. For the pump sizes 1SV-4SV, all the metal parts that are

in contact with the pumped liquid are made of stainless steel. They are available in different versions according to the position of the suction and delivery ports and the shape of the connection flanges. For the sizes 33SV-92SV, some of the metal parts in contact with the pumped liquid are made of stainless steel, others are made of cast iron. A special version is available, in which all the metal parts in contact with the pumped liquid are made of stainless steel. If you purchase a pump without the electric motor, make sure that the motor you use is suitable for coupling to the pump. The 33SV-92SV pumps are equipped with a special mechanical seal designed for easy replacement without having to disassemble the entire pump.

APPLICATIONS

These pumps are suitable for civil and industrial water distribution systems, pressure booster, irrigation (agriculture, sporting facilities), water treatment, boiler feed, parts washing, cooling - air conditioning - refrigeration and fire fighting applications.

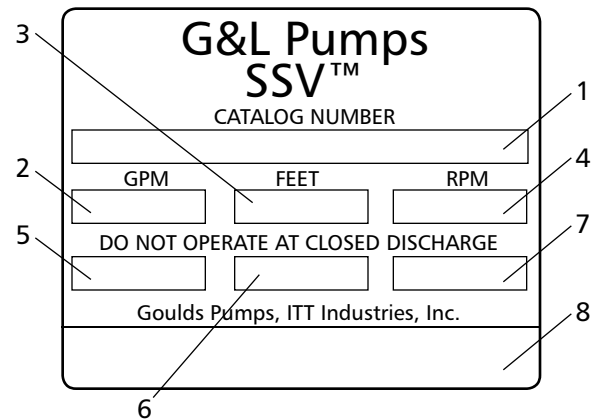

1	Goulds Catalog Number
2	Capacity Range
3	TDH Range
4	Rated Speed
5	Rated Horsepower
6	Maximum Operating Pressure
7	Maximum Operating Temperature
8	Pump Serial Number

PRE-INSTALLATION CHECKS

Confirm that the pump is capable of meeting the desired operating conditions.

1. MINIMUM INLET (SUCTION) PRESSURE

In general, the minimum suction pressure required is that which provides adequate NPSH_A necessary to feed the pump. The required NPSH_r, expressed in feet, can be found on the performance curve for the pump at the specific duty point. It is recommended that the NPSH_A exceeds the NPSH_r by a minimum of (2) two feet as a safety margin and to insure long term reliable performance of your SSV pump.

$$P_{s_{MIN}} = NPSH_r + 2 \text{ ft.}$$

NOTE: THE NPSH_A MUST BE CALCULATED FOR THE SPECIFIC SYSTEM TO WHICH THE SSV PUMP IS TO BE INSTALLED. PLEASE CONTACT YOUR DEALER/DISTRIBUTOR IF YOU REQUIRE ASSISTANCE.

2. MAXIMUM INLET PRESSURE

The following table shows the maximum permissible inlet pressure. However, the actual inlet pressure + pressure against a closed valve must always be lower than the maximum permissible operating pressure.

Pump	Number of Stages	Maximum Inlet Pressure
1SV	2-16 Stages	145 psi (10 bar)
	17-22 Stages	215 psi (15 bar)
2SV	2-15 Stages	145 psi (10 bar)
	16-22 Stages	215 psi (15 bar)
3SV	2-13 Stages	145 psi (10 bar)
	14-16 Stages	215 psi (15 bar)
4SV	2-10 Stages	145 psi (10 bar)
	11-12 Stages	215 psi (15 bar)
33SV	1-10 Stages	215 psi (15 bar)
46SV	1-10 Stages	
66SV	1-6 Stages	
92SV	1-6 Stages	

3. MAXIMUM OPERATING PRESSURE

(staging at 3500 RPM)

Series	At 250° F	PSI / Bar
1SV	2-16 Stages	325 / 25
	17-22 Stages	580 / 40
2SV	2-15 Stages	325 / 25
	16-22 Stages	580 / 40
3SV	2-13 Stages	325 / 25
	14-16 Stages	580 / 40
4SV	2-10 Stages	325 / 25
	11-12 Stages	580 / 40
33SV	1-6 Stages	362 / 25
	7-10 Stages	580 / 40
46SV	1-5 Stages	362 / 25
	6-10 Stages	580 / 40
66SV	1-5 Stages	362 / 25
	6 Stages	580 / 40
92SV	1-5 Stages	362 / 25

NOTE: Oval flange (1-3SV) maximum working pressure is 232 psi (16 bar).

4. TEMPERATURE CAPABILITY

The SSV pump is capable of pumping liquids within the below temperature range:

1-4SV -22° F to 250° F (-30° C to 120° C)
 33SV-92SV -22° F to 250° F (-30° C to 120° C)

NOTE: In order to provide adequate cooling for the electric motor, the ambient temperature must be 32° F to 104° F and the relative humidity at 104° F must not exceed 50%.

For temperatures above 104° F and for installations sites located at elevation in excess at 3000 feet above sea level it may be necessary to derate the motor performance. Please contact your distributor/dealer for assistance.

5. MINIMUM NOMINAL FLOW RATE

To prevent overheating of the internal pump components, make sure that a minimum water flow is always guaranteed when the pump is running.

For continuous operation the minimum flow rate recommended is specified below.

Pump Size		1SV	2SV	3SV	4SV
Min. Flow (gpm)	3500 RPM	3	6	12	17
	2900 RPM	3	6	10	14

Pump Size		33SV	46SV	66SV	92SV
Min. Flow (gpm)	3500 RPM	35	40	70	100
	2900 RPM	8	10	14	20

NOTE: If this cannot be archived, then a bypass/recirculate line is recommended.

▲ WARNING Do not run the pump against a closed discharge for longer than a few seconds.

6. NUMBER OF STARTS PER HOUR

For electric pumps coupled to motors supplied by Goulds Pumps, the maximum number of work cycles (starts and stops) in one hour are as follows:

HP	3/4-3	5-10	15-20	25-75
# of Starts	30	20	15	12

▲ WARNING If you use a different motor from the standard one supplied by Goulds Pumps, please consult with the motor manufacturer to find out the maximum number of work cycles allowed.

7. POWER SUPPLY REQUIREMENTS

▲ WARNING Make sure that the supply voltages and frequencies are suited to the characteristics of the electric motor. Check the motor rating plate.

In general, the supply voltage tolerances for motor operation are as follows:

f Hz	Phase	U _N	
		V	±%
60	1	230	6
60	3	230 / 460	5
60	3	460	5

TRANSPORTATION AND STORAGE

1. TRANSPORTATION AND HANDLING OF PACKED PRODUCT

The SSV pump is packed in cartons or wooden crates having different dimensions and shapes.

▲ WARNING Some cartons (the supporting base is made of wood) are designed to be transported and handled in the vertical position. Other cartons, as well as the wooden crates, are designed to be transported and handled in the horizontal position. Protect the product against humidity, heat sources and mechanical damage (collisions, falls, ...). Do not place heavy weights on the cartons.



Lift and handle the product carefully, using suitable lifting equipment. Observe all the accident prevention regulations.

When you receive the pump, check the outside of the package for evident signs of damage. If the product bears visible signs of damage, notify our distributor within 8 days from the delivery date.

2. STORING THE PACKED PRODUCT

Ambient temperature 32° F to 104° F.

Short Term: (Less than 6 months) Goulds Pumps normal packaging procedure is designed to protect the pump during shipping. Upon receipt, store in a covered and dry location.

Long Term: (More than 6 months) Rotate shaft several times every 3 months. Refer to driver and coupling manufacturers for their long term storage procedures. Store in a covered dry location.

3. UNPACKING THE PRODUCT



Use suitable equipment. Observe all the accident prevention regulations in force. Lift and handle the product carefully, using suitable lifting equipment.

When you receive the pump, check the outside of the package for evident signs of damage. If the product bears visible signs of damage, notify our distributor within 8 days from the delivery date.

4. HANDLING THE PRODUCT



Lift and handle the product carefully, using suitable lifting equipment. Observe the accident prevention regulations in force.

The product must be securely harnessed for lifting and handling. Some electric pumps have eyebolts that can be used for this purpose.

INSTALLATION



The installation operations must be carried out by qualified and experienced personnel. Use suitable equipment and protections.

Observe the accident prevention regulations in force.

Always refer to the local and/or national regulations, legislation and codes in force relating to the selection of the installation site and the water and power connections.

1. SITE SELECTION

Make sure that no obstructions or obstacles hinder the normal flow of the cooling air delivered by the motor fan. Make sure there is adequate clearance around the pump for the maintenance operations. Whenever possible, raise the pump slightly from the level of the floor. See the figures below and at the top of the next column for possible installation configurations.

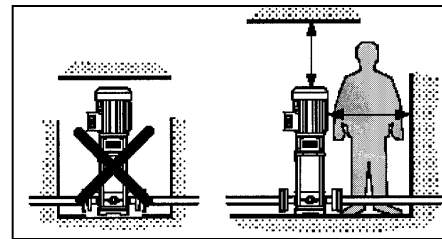
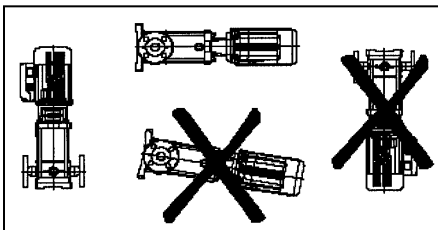

2. ANCHORING

The pump must be anchored securely with bolts to a concrete foundation or equivalent metal structure (shelf or platform). If the pump is large-sized and needs to be installed near rooms inhabited by people, suitable vibration-damping supports should be provided to prevent the transmission of the vibrations from the pump to the reinforced concrete structure. The dimensions of the pump base and anchoring holes are shown.

	1SV	2SV	3SV	4SV	33SV	46SV	66SV	92SV
	Inches (mm)							
L1	3.94 (100)		5.12 (130)		6.69 (170)		7.48 (190)	
L2	7.09 (180)		8.46 (215)		9.44 (240)		10.44 (265)	
L3	5.91 (150)		7.48 (190)		8.66 (220)		9.44 (240)	
L4			9.65 (245)		11.42 (290)		12.4 (315)	
ØA	0.50 (13)				0.60 (15)			
N	4							

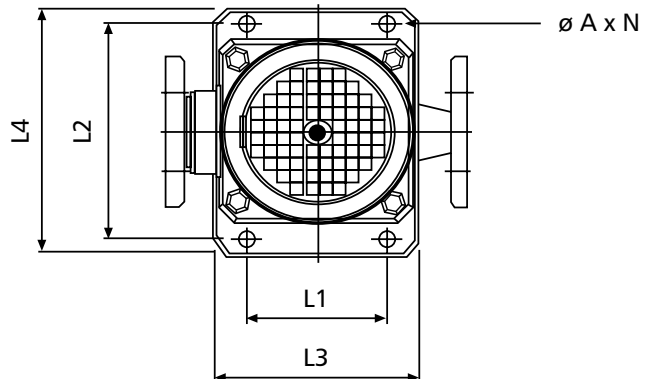

3. ANGULAR ALIGNMENT

Angular alignment of the suction and discharge flanges can best be accomplished using calipers at the bolt locations. See figure below.

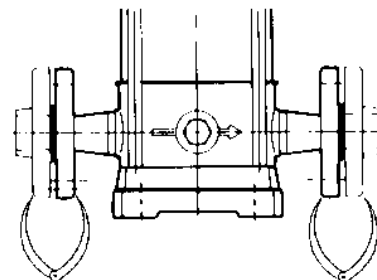

NOTICE: DO NOT DRAW PIPING INTO PLACE BY FORCING THE PUMP SUCTION OR DISCHARGE CONNECTIONS.

4. PIPING

Discharge and suction piping should be no smaller than the respective pump opening and should be kept as short as possible, avoiding unnecessary fittings to minimize friction losses.

NOTICE: PIPING MUST BE INDEPENDENTLY SUPPORTED AND NOT PLACE ANY PIPING LOADS ON THE PUMP.

If suction piping larger than pump suction is required, an eccentric pipe reducer, **WITH THE STRAIGHT SIDE UP**, must be installed at the pump suction.

If the pump is installed below the liquid source, install a full flow isolation valve in the suction piping for pump inspection or maintenance.

NOTICE: DO NOT USE THE ISOLATION VALVE ON THE SUCTION SIDE OF THE PUMP TO THROTTLE PUMP. THIS MAY CAUSE LOSS OF PRIME, EXCESSIVE TEMPERATURES, DAMAGE TO PUMP AND VOID WARRANTY.

If pump is installed above the liquid source, the following **MUST** be provided:

To avoid air pockets, no part of the suction piping should be above the pump suction.

On any horizontal piping sections, slope piping upward from liquid source.

All suction pipe joints **MUST** be airtight.

Use a foot valve for priming, or for holding prime during intermittent duty.

The suction strainer or suction bell **MUST** be at least 3 times the suction pipe diameter.

Insure that the size and minimum liquid submergence, over the suction inlet, is sufficient to prevent air from entering through a suction vortex. See typical suction piping Figures 1 through 4.

Install a discharge check valve, suitable to handle the flow and liquids, to prevent backflow.

Install an appropriately sized gate valve, **AFTER** the discharge valve, to regulate the pump capacity, for pump inspection and for maintenance.

When a pipe increaser is required, install between the check valve and the pump discharge.

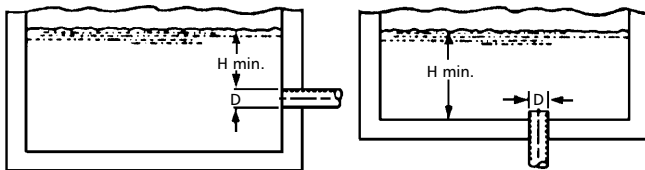

Figure 1

Figure 2

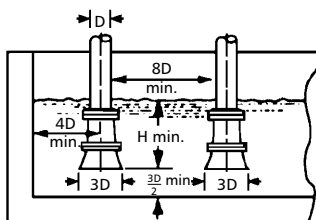

Figure 3

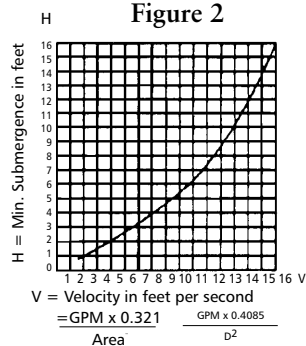

Figure 4

5. SHAFT ALIGNMENT – MOTOR TO PUMP

When the pump is purchased less motor, the pump will be supplied with a motor assembly shim positioned between the motor adapter and the coupling.

To assemble the motor to the pump remove the plastic shipping straps, the 2 stainless steel coupling guard halves, and the expanded polyurethane.

Insure that the motor assembly shim is properly positioned between the coupling and the motor adapter. If the motor assembly shim is not available, a 0.203" (5 mm) shim may be used to locate the pump shaft assembly and to set the correct height. See figures below.

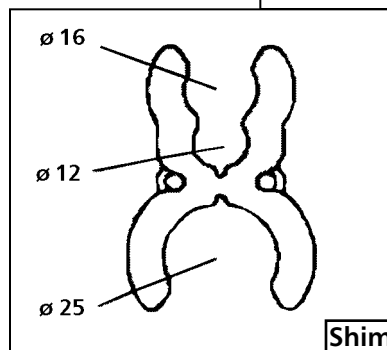
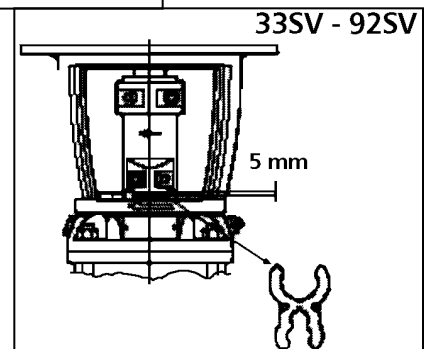
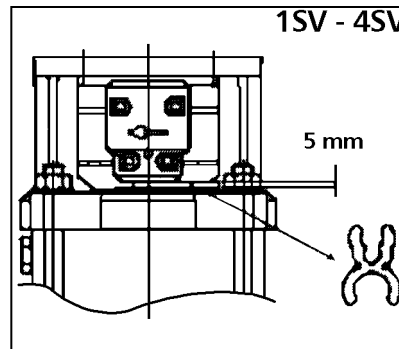

For motor frame sizes 213TC and larger, attach the motor adapter flange to the motor using 4 hex cap screws. Torque to values shown in the “ENGINEERING DATA” section of this manual.

Loosen the 4 coupling socket head screws enough to provide an adequate opening in the coupling to receive the motor shaft.

With an adequately sized crane, carefully lower the motor assembly onto the pump motor adapter and into the coupling. Secure the 4 motor hex cap screws, torquing to the value provided in the “ENGINEERING DATA” section of this manual.

Torque the 4 coupling socket head screws to the value provided in “ENGINEERING DATA” section of this manual.

For the 33 through 92SV sizes using a cartridge seal, after coupling bolts have been properly torqued, there are four set screws on the collar of the cartridge seal that require tightening before removing the shim. The four hex head set screws require a 1/8" allen wrench and are to be tightened hand-tight approximately 5 lbs.-ft. (7 N•m).

Remove the motor assembly shim and retain for future use.

Install the 2 coupling guard halves.

START-UP

1. WATER CONNECTION

The water connections must be made by qualified installation technicians in compliance with the regulations in force.

In case of connection to the water system, the regulations issued by the competent authorities (municipal, public utility company) must be observed. Authorities often require the installation of a back-flow prevention device, such as a disconnect, check valve or disconnection tank.

2. WIRING AND GROUNDING



- ⚠ Install, ground and wire according to local and National Electrical Code requirements.
- ⚠ Install an all leg disconnect switch near pump.
- ⚠ Disconnect and lockout electrical power before installing or servicing pump.

⚠ Electrical supply **MUST** match pump's nameplate specifications. Incorrect voltage can cause fire, damage motor and voids warranty.

⚠ Motors equipped with automatic thermal protectors open the motor's electrical circuit when an overload exists. This can cause the pump to start unexpectedly and without warning.

Use only stranded copper wire to motor and ground. Wire size **MUST** limit the maximum voltage drop to 10% of the motor nameplate voltage, at the motor terminals. Excessive voltage drop will affect performance and void motor warranty. The ground wire must be at least as large as the wires to the motor. Wires should be color coded for ease of maintenance.

Three phase motors require all leg protection with properly sized magnetic starters and thermal overloads.

HAZARDOUS VOLTAGE
PERMANENTLY GROUND THE PUMP, MOTOR AND CONTROLS PER NEC OR LOCAL CODES BEFORE CONNECTING TO ELECTRICAL POWER. FAILURE TO DO SO CAN CAUSE SHOCK, BURNS OR DEATH.

Connect the electrical leads to the motor, as follows:

Single Phase Motors – Connect the BLACK wire to the BLACK motor wire. Connect the WHITE wire to the WHITE motor wire. Connect the GREEN wire to the GREEN motor wire.

Three Phase Motors – See figure below.

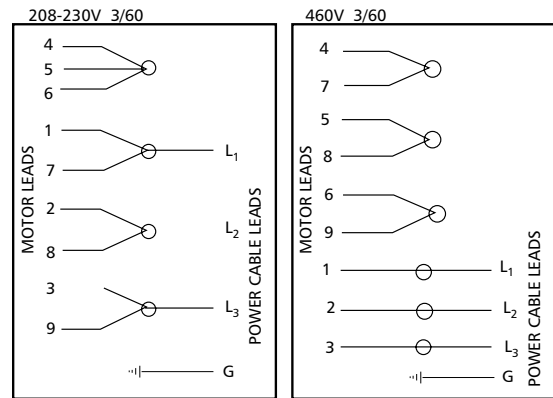

THREE PHASE MOTOR WIRING DIAGRAM

NOTICE: UNIT ROTATION IS CLOCKWISE WHEN VIEWED FROM MOTOR END. INCORRECT ROTATION MAY CAUSE DAMAGE TO THE PUMP AND VOIDS WARRANTY.

Check pump rotation by observing the motor fan or the coupling **THROUGH** the coupling guard. **DO NOT** confuse the flow arrows, stamped on the pump body, with the rotation arrows on the coupling and motor adapter. Three phase motors only – If rotation is incorrect, have a qualified electrician interchange any two of the three power cable leads.

3. PRIMING/VENTING

For installations with the liquid level above the pump:

Close the discharge valve.

Remove the vent plug.

For models 1SV and 2SV only, it is necessary to fully unscrew the pin located in the drain plug. See figure below.

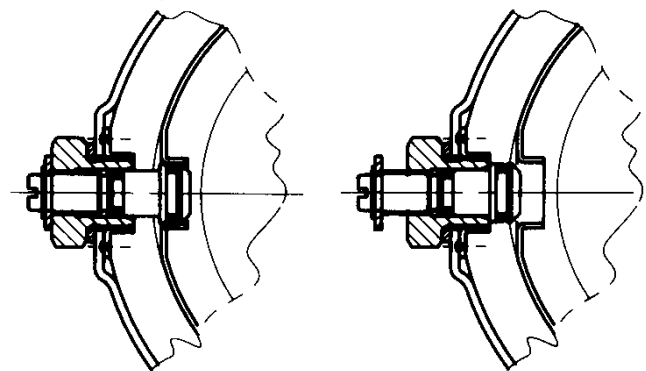

DRAIN PLUG WITH PIN CLOSED

DRAIN PLUG WITH PIN OPEN

For sizes 33SV-92SV the vent plug is supplied with an internal needle valve, so it is not necessary to remove the vent plug. Simply unscrew the needle valve half way to open the valve to allow air to escape. (For sizes 33SV-92SV, if the pump is supplied with a cartridge seal, remove the vent plug located on the gland plate beneath the coupling.)

Open the suction valve until liquid flows out of the vent plug opening.

NOTE: Place a loose rag over the open vent port to prevent large amounts of liquid from being sprayed on the pump and adjacent equipment.

CAUTION Care should be exercised if you are pumping hot water or chemicals to avoid personal injury.

Install and torque the vent plug to the values provided in the “ENGINEERING DATA” section of this manual. Close the drain plug pin (1SV and 2SV only) and open the discharge valve.

For installations with the liquid level below the pump:

Install foot valve at suction end.

For models 1SV and 2SV only, it is necessary to fully unscrew the pin located in the drain plug. See figure on previous page.

With the provided plastic funnel, completely fill the casing with liquid.

Install and torque the vent plug, close the drain plug pin (1SV and 2SV only) and open the suction valve.

4. OPERATION



DO NOT OPERATE UNIT WITHOUT SAFETY GUARD IN PLACE. TO DO SO CAN CAUSE SEVERE PERSONAL INJURY.

NOTICE: PUMP MUST BE COMPLETELY PRIMED BEFORE OPERATION.



DO NOT OPERATE PUMP AT OR NEAR ZERO FLOW. TO DO SO CAN CAUSE EXTREME HEAT, DAMAGE TO THE PUMP, INJURY OR PROPERTY DAMAGE.

OPERATION

Start the pump, keeping the on-off valve downstream from the pump closed. Open the on-off valve gradually. The pump must run smoothly and noiselessly. If necessary, reprime the pump. Check the current absorbed by the motor and, if necessary, adjust the setting of the thermal relay. Any air pockets trapped inside the pump may be released by loosening the fill plug, for the 1SV-4SV pumps, or by turning the air screw for the 33SV-92SV pumps.

WARNING If a pump installed in a location where freezing may occur remains inactive, you must drain it through the drain plugs. This operation is not necessary if a suitable anti-freeze has been added to the water.



Make sure that the drained liquid does not cause damage or injuries.

After stabilizing the system at normal operating conditions, check piping for correct alignments. If necessary, adjust pipe supports.



HAZARDOUS MACHINERY. MOTOR THERMAL PROTECTORS CAN RESTART MOTOR UNEXPECTEDLY AND WITHOUT WARNING, CAUSING SEVERE PERSONAL INJURY.

See the “ENGINEERING DATA” section in this manual for the recommended maximum pump starts per hour.

MAINTENANCE



DISCONNECT AND LOCKOUT ELECTRICAL POWER BEFORE ATTEMPTING ANY MAINTENANCE. FAILURE TO DO SO CAN CAUSE SHOCK, BURNS OR DEATH.

MOTOR LUBRICATION

Recommended Motor Bearing Lubrication Intervals

Interval	Service Environment
1 – 2 Years	Light Duty in Clean Atmosphere
1 Year	8 – 16 hours/day – Clean, Dry Atmosphere
6 Months	12 – 24 hours/day – Moisture Present
3 Months	12 – 24 hours/day – Dirty, High Moisture

When lubricants are operated at elevated temperatures, the lubrication frequency should be increased.

DO NOT intermix grease bases (lithium, sodium, etc.). Completely purge old grease if changing grease base.

Over greasing can cause excessive bearing temperatures, lubricant and bearing failure.

MECHANICAL SEAL REPLACEMENT (SIZES 1SV-4SV)

MECHANICAL SEAL OPTIONS

Code No.	Rotary	Stationary	Elastomers	Reference Application	Replacement Mechanical Seal Part Number	
					1SV/2SV	3SV/4SV
0	High Temp Carbon	Silicon Carbide (Graphite filled)	Viton	General Service	10K93	10K94
4	Silicon Carbide			Abrasive	10K99	10K100
6	High Temp Carbon		EPR	Boiler Feed	10K96	10K97

Metal parts on all seals are 316SS. When reordering units with previous seal options 2, 3 or 5 review application and order new seal option from above chart.

1. Close all necessary suction and discharge valves.
2. Drain the liquid from the pump by removing the lower drain plug and the upper vent plug.

3. Remove the coupling guards, the 4 coupling hex cap screws, the coupling and coupling drive pin.
4. Remove the 4 motor hex cap screws. On units with motor frames 213TC and larger, remove the 4 motor adapter flange hex cap screws. With an adequately sized crane, carefully remove the motor. **DO NOT** rest the motor on the motor shaft.
5. Remove the 4 tie rod nuts and lock washers.
6. Carefully remove the motor adapter by sliding it up the pump shaft. Larger units may require an adequately sized crane to lift the motor adapter. **DO NOT** damage the shaft.

NOTICE: EDGES OF THE STAINLESS STEEL PARTS ARE SHARP. WEAR APPROPRIATE PROTECTIVE CLOTHING.

7. To gain access to the mechanical seal, it is necessary to remove the stainless steel upper plate which is held in place by an O-ring located under the plate rim. Place a small block of wood against the underside of the rim and, while moving around the rim, tap with a mallet against the block until the upper plate loosens. Remove the upper plate and O-ring from the pump casing. Discard the O-ring.
8. Remove the stationary element from the upper plate. With a clean cloth, wipe the upper plate bore clean and inspect for damage. Replace the upper plate, as required.
9. Remove the top (vented) stainless steel inner casing. Grasp the pump shaft, below the mechanical seal, and move it sharply back and forth to free the first stage from the lower pump body. Remove the entire stack assembly from the pump external sleeve.
10. Slide the mechanical seal rotary element, spring and washer from the pump shaft. Discard the entire mechanical seal assembly.
11. Lubricate the inside of the new mechanical seal assembly with a quality grade of O-ring lubricant.
12. To install a new mechanical seal rotary assembly, slide the assembly onto the pump shaft, spring end first. Be sure the top spring tip is in the hole of the rotary portion of the seal. **DO NOT** scratch or otherwise damage the seal face. With a clean, lint free cloth, wipe the seal face clean of all lubricant or debris.
13. Lubricate the outside of the new mechanical seal stationary element with a quality grade of O-ring lubricant.
14. Insert the stationary seat into the seal housing with the seal face out. **DO NOT** scratch or otherwise damage the seal face. Insure that the stationary seat is fully seated into the seal housing. With a clean, lint free cloth, wipe the seal face clean of all lubricant or debris.
15. With a new O-ring, install the seal housing onto the pump shaft, seating the plate fully and squarely onto the pump outer shell.
16. Place the motor adapter over the 4 tie rod bolts, using an adequately sized crane when required,

and install the 4 lock washers and tie rod nuts. Torque the nuts, in sequence, to the value provided in the “ENGINEERING DATA” section of this manual.

17. With an adequately sized crane, carefully lower the motor onto the motor adapter, lining up the electrical conduit connection and the 4 motor adapter bolt holes, as required.
18. Install the 4 motor hex cap screws, torquing to the value provided in the “ENGINEERING DATA” section of this manual.
19. Place the coupling drive pin into the pump shaft and install the coupling halves onto the motor and pump shafts. Install the 4 coupling socket head screws, lock washers and nuts, **DO NOT** tighten.
20. Position the motor assembly shim between the coupling and the motor adapter. If the motor assembly shim is not available, a 0.203" (5 mm) shim may be used to locate the pump shaft assembly and to set the correct height.
21. Tighten the 4 coupling socket head screws, torquing screws to values provided in the “ENGINEERING DATA” section of this manual. Tighten evenly so that the gap between the halves is equal side to side and top to bottom.
22. Install the 2 coupling guard halves.

A MECHANICAL SEAL REPLACEMENT (SIZES 33SV-92SV)

MECHANICAL SEAL OPTIONS

	Code No.	Rotary	Stationary	Elastomers	Part Number			
					33SV	46SV	66SV	92SV
Mechanical Seal	A	Silicon Carbide	Carbon	Viton	10L38			
	B			EPR	10L40			
	C		Silicon Carbide	Viton	10L39			
	D			EPR	10L37			
Cartridge Seal	L		Carbide	Viton	10K163			
	P		Sil/Carbide	EPR	10K166			

Metal parts on all seals are 316SS. When reordering units with previous seal options 2, 3 or 5 review application and order new seal option from above chart.

1. Close all necessary suction and discharge valves to isolate the pump from the system.
2. Drain the liquid from the pump by removing the drain plug and opening the needle valve on the vent plug.
3. Remove the coupling guards, the 4 coupling hex cap screws, the coupling and coupling drive pin. See steps 1-3.
4. Remove the 4 motor hex cap screws (inner screws) on the seal housing. See step 4.
5. Remove the seal housing plate using the two tapped holes provided. Threading 2 of the hex cap screws into these holes and evenly tightening the screws. Lift and remove the seal housing between the pump and motor shaft. Exercise care when sliding the seal housing between the shaft to prevent damage to the stationary seat. See step 5.

6. Turn the seal housing upside down and remove the stationary seat and o-ring. Remove and discard the large o-ring used to seal the seal housing to the pump head. Inspect the seal seat for any burrs or debris. Make sure that the seat is clean. Lubricate the new o-ring for the seal seat with a lubricant compatible with the o-ring and install the new seat by pressing it into the seal housing with your thumb. **DO NOT USE EXCESSIVE FORCE** and, if possible, place a clean soft cloth over the seal face to protect the seal faces during installation.

7. Remove the rotary portion at the mechanical seal by sliding the rotary unit axially upwards along the pump shaft. Inspect the pump shaft for any burrs or debris. Any burrs should be ground smooth with (fine grit) emery paper. See step 7 in Figure 5.

8. Lubricate the o-ring located in the ID of the rotary unit of the mechanical seal with a lubricant compatible with the seal elastomers. Carefully slide the rotary unit of the mechanical seal down the shaft. Rotate the seal to locate the pin on the bottom of the seal with the holes in the shaft sleeve. See step 8 in Figure 5.

9. Install a new seal housing o-ring on the seal housing. A lubricant can be used to hold the o-ring on the diameter of the seal housing.

Carefully reinstall the seal housing between the pump and motor shaft and slide the seal housing down the shaft into position. Use caution when mounting the sealhousing between the pump/motor shaft so that the seal face on the stationary seat is not damaged. See step 9 in Figure 5.

10. Reinstall the 4 hex cap screws tightening the screws evenly and then torquing them to the values given in the engineering data. See step 10 in Figure 5.

11. Reinstall the coupling pin and locate the space shim on the shaft on the seal housing. If the shim is not available, a 5 mm spacer can be used. See step 11 in Figure 5.

12. Reinstall the coupling halves and evenly tighten the coupling bolts and torque them to the values given in the coupling section. Remove the spacer shim and save for future use. See step 12 in Figure 5.

13. Rotate the shaft by hand to insure that the pump and motor rotate freely. Reinstall the coupling guard.

14. The pump and system should be vented prior to starting the pump. See Section 3, page 8, for venting procedures.

2. Loosen the 4 set screws located around the ID of the pump shaft.

3. Remove the cartridge seal using the two tapped holes provided on the gland of the cartridge seal by threading two of the hex cap screws into these holes and evenly tightening these screws. Lift and remove the cartridge seal between the pump and motor shaft.

4. Inspect the pump shaft for any burrs or debris. Any burrs should be ground smooth with (fine grit) emery paper.

5. Install a new o-ring on the turned fit of the new cartridge seal. Lubricate the o-ring located in the ID of the cartridge seal. Use a lubricant compatible with the seal elastomers to hold the o-ring.

6. Install the new cartridge seal on the pump by carefully sliding it between the pump and motor shaft and then sliding it into position.

7. Complete steps 11-14 as defined above for the conventional seals.

8. After installing the coupling, tighten the four set screws located in the collar of the cartridge seal to secure the seal to the pump shaft.

9. Rotate the shaft by hand to insure that the pump and motor rotate freely. Reinstall the coupling guard.

10. Use vent connections on cartridge seal for proper venting.

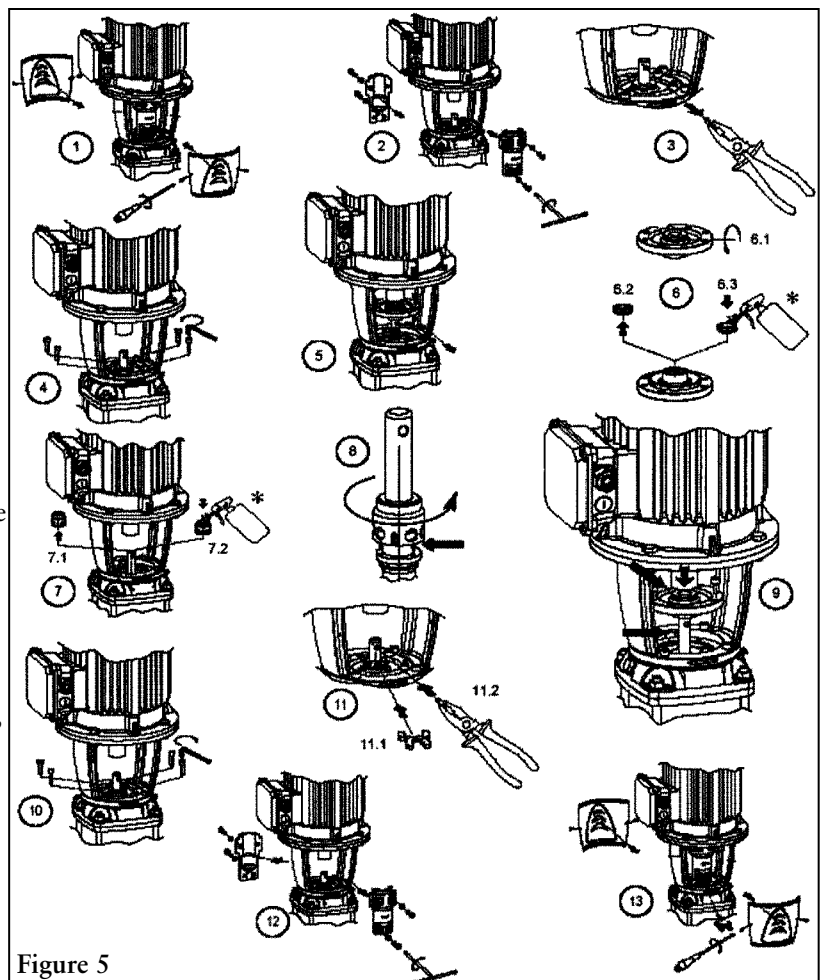

Figure 5

MECHANICAL SEAL REPLACEMENT (SIZES 33SV-92SV) FITTED WITH CARTRIDGE SEALS

1. Complete steps 1-4 as defined above for conventional seals.

MOTOR REPLACEMENT

To remove the motor follow steps 1 through 4, as provided in the “MECHANICAL SEAL REPLACEMENT” section of this manual.

For motor frames 213TC and larger, remove the 4 motor hex cap screws and the motor adapter.

Install the motor adapter flange onto the new motor, torquing the 4 hex cap screws to the values provided in the “ENGINEERING DATA” section of this manual.

Complete the reassembly following steps 17 through 22 in the “MECHANICAL SEAL REPLACEMENT” section of this manual.

All additional unit service or maintenance, not addressed in this manual, should be performed at a qualified service location. Contact your local dealer or G&L Pumps distributor for assistance.

TROUBLESHOOTING GUIDE

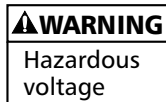

DISCONNECT AND LOCKOUT ELECTRICAL POWER BEFORE ATTEMPTING ANY MAINTENANCE. FAILURE TO DO SO CAN CAUSE SHOCK, BURNS, OR DEATH.

SYMPTOM

MOTOR NOT RUNNING

See Probable Cause – 1 through 5

LITTLE OR NO LIQUID DELIVERED BY PUMP

See Probable Cause – 6 through 12

POWER CONSUMPTION TOO HIGH

See Probable Cause – 3, 12, 13, 15

EXCESSIVE NOISE AND VIBRATION

See Probable Cause – 3, 6 - 8, 10, 12, 13, 16

PROBABLE CAUSE

1. Motor thermal protector tripped.
2. Open circuit breaker or blown fuse.
3. Impellers binding.
4. Motor improperly wired.
5. Defective motor.
6. Pump is not primed, air or gases in liquid.
7. Discharge, suction plugged or valve closed.
8. Incorrect rotation (three phase only).
9. Low voltage or phase loss.
10. Impellers worn or plugged.
11. System head too high.
12. NPSHA too low – excessive suction lift or losses.
13. Discharge head too low – excessive flow rate.
14. Fluid viscosity, specific gravity too high.
15. Worn bearing.
16. Pump, motor or piping loose.

ENGINEERING DATA

Maximum Working Pressure = 230 psi (16 bar) with the oval suction and discharge flanges.
See chart on page 5.

Maximum Liquid Temperature = 250° F (138° C)

ELECTRICAL DATA

HP	Motor Frame	RPM	Voltage	Phase/Hz	Starts/Hour
¾	56C	3600	230	1/60	30
			208 – 230/460	3/60	30
1	56C	3600	230	1/60	30
			208 – 230/460	3/60	30
1½	56C	3600	230	1/60	30
			208 – 230/460	3/60	30
2	56C	3600	230	1/60	30
			208 – 230/460	3/60	30
3	56C	3600	230	1/60	30
			208 – 230/460	3/60	30
5	184TCH	3600	230	1/60	20
			208 – 230/460	3/60	20
7½	184TCH	3600	230	1/60	20
			208 – 230/460	3/60	20
10	213TC 225TC	3600	230	1/60	20
			208 – 230/460	3/60	20
15	215TC 254TC	3600	230	1/60	15
			208 – 230/460	3/60	15
20	254TC 256TC	3600	208 – 230/460	3/60	15
25	256TC 284TC	3600	208 – 230/460	3/60	12
30	284TC 286TC	3600	208 – 230/460	3/60	12
40	284TC 286TC	3600	208 – 230/460	3/60	12
50	324TSC 326TSC	3600	208 – 230/460	3/60	12
60	326TSC 364TSC	3600	208 – 230/460	3/60	12
75	365TSC	3600	208 – 230/460	3/60	12

TORQUE VALUES

HP	Motor Frame	Motor Bolt	Adapter Flange	Coupling	
				1-4SV	33-92SV
¾	56C	20 lbs ft (27 N .m)	–	15 lbs ft (20 N .m)	
1	56C	20 lbs ft (27 N .m)	–	15 lbs ft (20 N .m)	
1½	56C	20 lbs ft (27 N .m)	–	15 lbs ft (20 N .m)	
2	56C	20 lbs ft (27 N .m)	–	15 lbs ft (20 N .m)	
3	56C	20 lbs ft (27 N .m)	–	15 lbs ft (20 N .m)	
5	184TC	20 lbs ft (27 N .m)	–	15 lbs ft (20 N .m)	37 lbs ft (50 N .m)
7½	184TC	20 lbs ft (27 N .m)	–	15 lbs ft (20 N .m)	37 lbs ft (50 N .m)
10	213TC 215TC	45 lbs ft (61 N .m)	30 lbs ft (40 N .m)	30 lbs ft (40 N .m)	55 lbs ft (75 N .m)
15	215TC 254 TC	45 lbs ft (61 N .m)	30 lbs ft (40 N .m) 48 lbs ft (65 N .m)	30 lbs ft (40 N .m) 48 lbs ft (65 N .m)	55 lbs ft (75 N .m)
20	254TC 256TC	45 lbs ft (61 N .m)	48 lbs ft (65 N .m)	48 lbs ft (65 N .m)	55 lbs ft (75 N .m)
25	256TC 284TC	45 lbs ft (61 N .m)	48 lbs ft (65 N .m)	48 lbs ft (65 N .m)	55 lbs ft (75 N .m)
30	284TC 286TC	45 lbs ft (61 N .m)	48 lbs ft (65 N .m)	48 lbs ft (65 N .m)	55 lbs ft (75 N .m)
40	284TC 286TC	45 lbs ft (61 N .m)	48 lbs ft (65 N .m)		55 lbs ft (75 N .m)
50	324TSC 326TSC	45 lbs ft (61 N .m)	48 lbs ft (65 N .m)		55 lbs ft (75 N .m)
60	326TSC 364TSC	45 lbs ft (61 N .m)	48 lbs ft (65 N .m)		55 lbs ft (75 N .m)
75	365TSC	45 lbs ft (61 N .m)	48 lbs ft (65 N .m)		55 lbs ft (75 N .m)

TORQUE VALUES

Pump Size	Tie Rod Nuts	Vent and Drain
1SV	22 lbs ft (30 N .m)	15 lbs ft (20 N .m)
2SV	22 lbs ft (30 N .m)	15 lbs ft (20 N .m)
3SV	37 lbs ft (50 N .m)	15 lbs ft (20 N .m)
4SV	37 lbs ft (50 N .m)	15 lbs ft (20 N .m)
33, 46, 66, 92SV	44 lbs ft (60 N .m)	29 lbs ft (40 N .m)

TYPICAL PLUMBING AND INSTALLATION

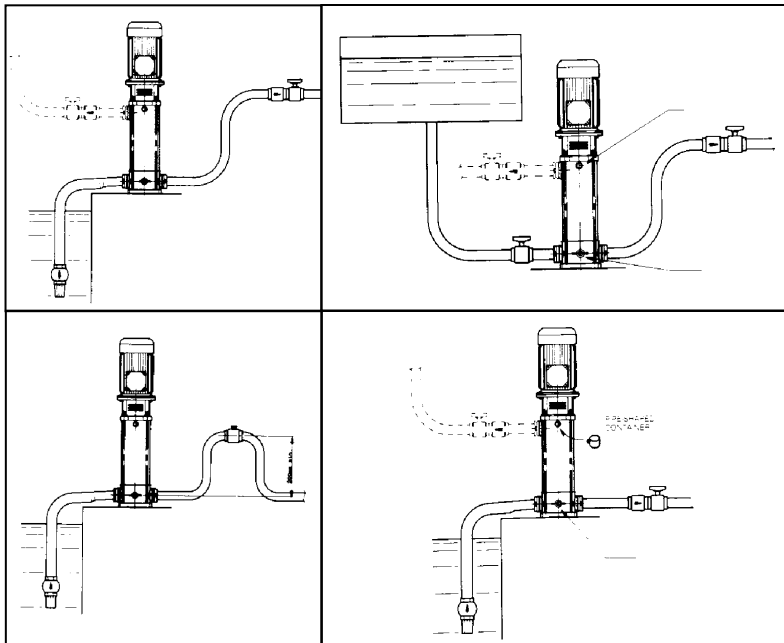

NOTE: Discharge loop must be high enough to keep liquid in the bottom stages during shut-down.

1SV, 2SV, 3SV AND 4SV MAJOR COMPONENTS

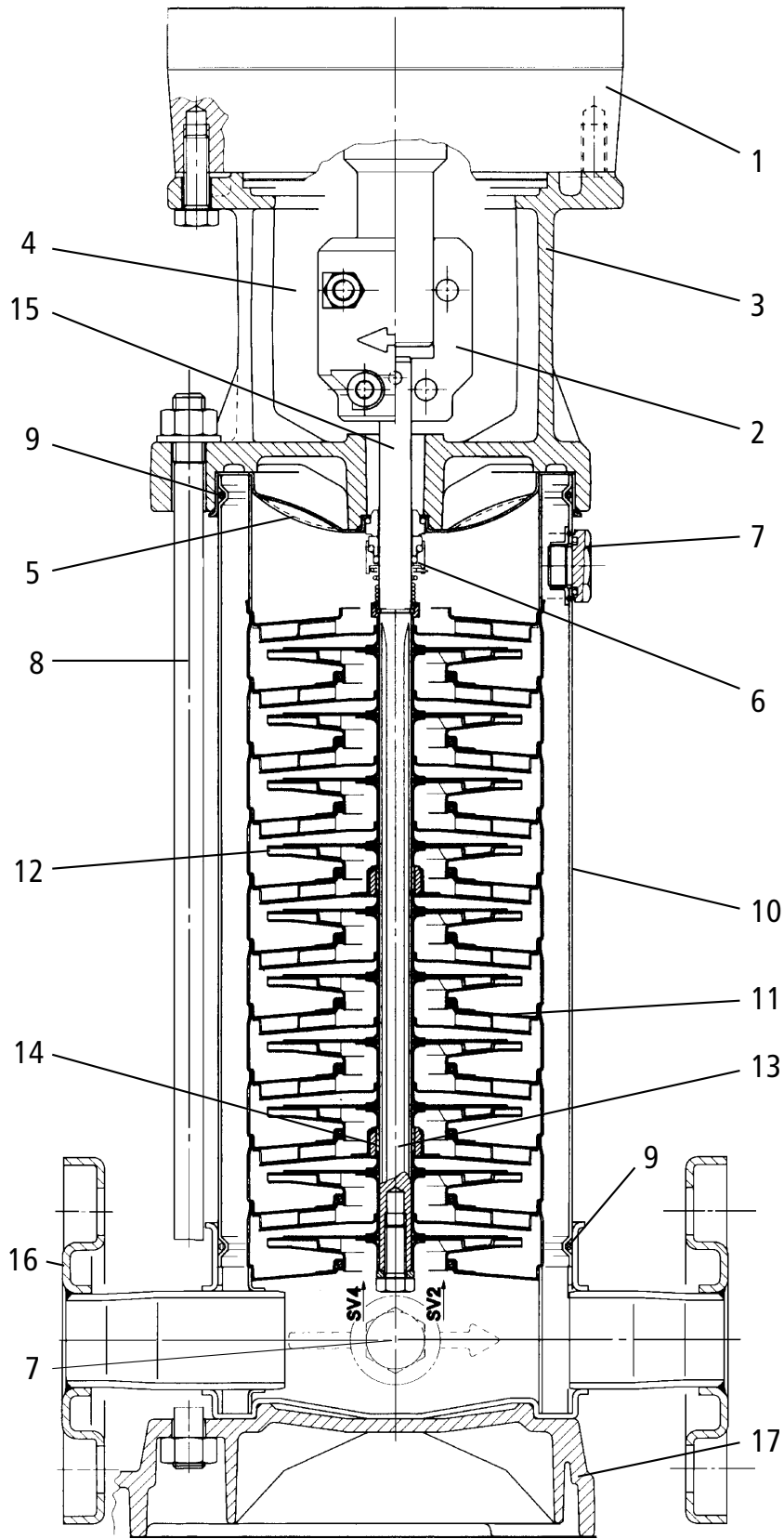

- 1 Standard NEMA vertical motor
- 2 Rigid coupling
- 3 Motor adapter
- 4 Coupling guard
- 5 Stainless steel seal housing
- 6 Mechanical seal
- 7 Stainless steel fill and drain plugs
- 8 Tie-rods
- 9 O-ring
- 10 Stainless steel pump casing
- 11 Stainless steel diffuser
- 12 Stainless steel impeller
- 13 Tungsten carbide shaft sleeve
- 14 Ceramic bushing
- 15 Stainless steel shaft
- 16 Stainless steel pump body
- 17 Pump base

33SV — 92SV MAJOR COMPONENTS

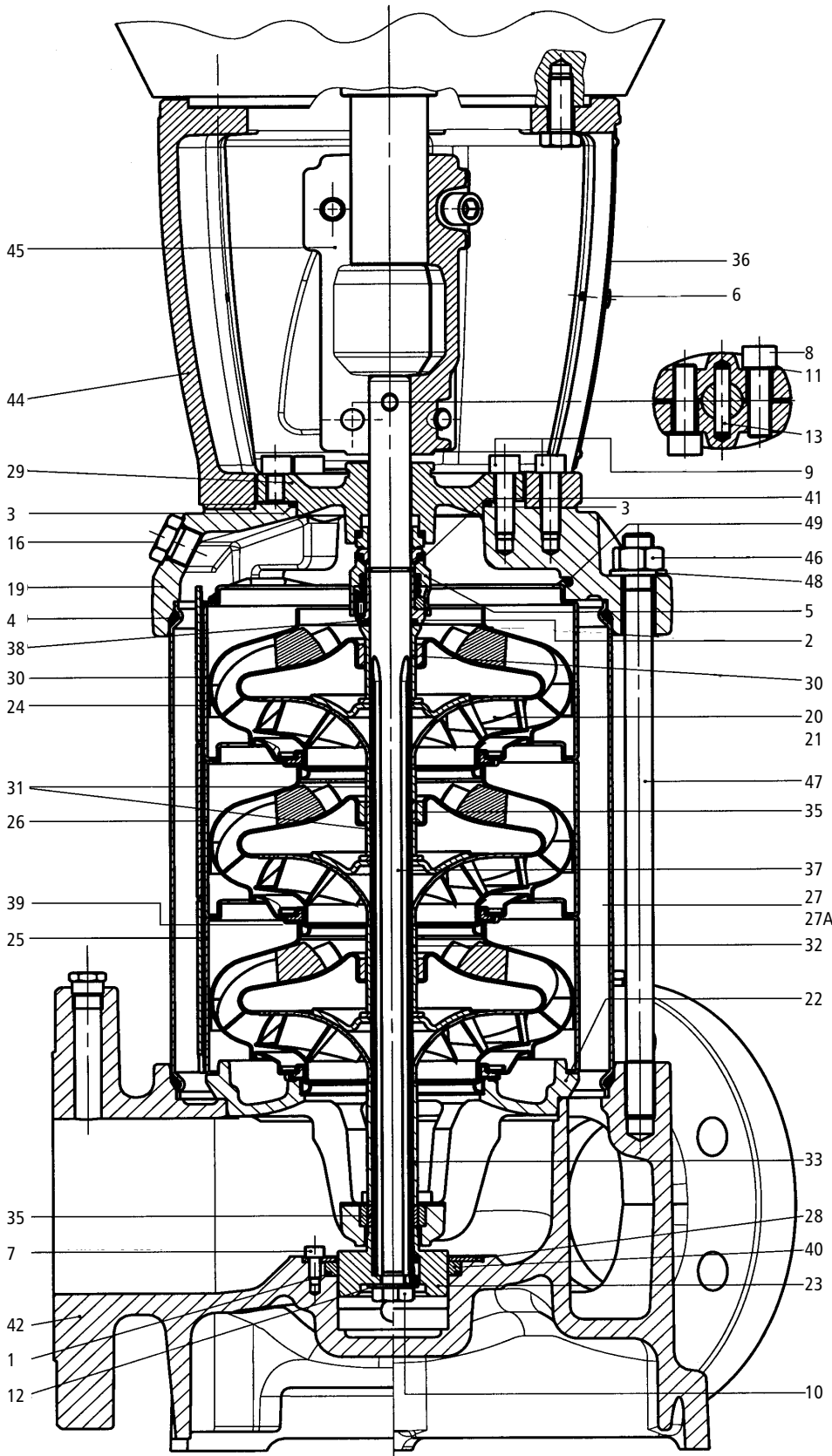

- 1 O-Ring, Piston Seal
- 2 O-Ring, Mechanical Seal
- 3 O-Ring, Seal housing
- 4 O-Ring, Sleeve
- 5 Mechanical Seal
- 5A Cartridge Seal (not shown)
- 6 Screw, Guard
- 7 Screw, Piston Holding Disc
- 8 Screw, Coupling
- 9 Screw, MA and Seal Housing
- 10 Screw, Impeller
- 11 Washer, Coupling
- 12 Washer, Impeller
- 13 Pin, Coupling
- 14 Plug, with Piston
- 15 Plug, without Piston
- 16 Plug, Fill
- 17 Plug, Vent (not shown)
- 18 Plug, Drain
- 19 Pump Head
- 20 Impeller, Full Diameter
- 21 Impeller, Reduced Diameter
- 22 Lower Bearing Assembly
- 23 Piston
- 24 Diffuser, Final
- 25 Diffuser with Carbon Bushing
- 26 Diffuser with Tungsten Bushing
- 27 Outer Sleeve, 25 Bar
- 27A Outer Sleeve, 40 Bar
- 28 Holding Disc, Piston Seal
- 29 Seal Housing
- 30 Spacer, Impeller Final
- 31 Spacer, Shaft Bushing
- 32 Spacer, Impeller
- 33 Spacer, Impeller Lower (66-92SV)
- 34 Bushing, Non-Piston
- 35 Tungsten Carbide Bushing
- 36 Coupling Guard
- 37 Shaft
- 38 Mechanical Seal Shaft Sleeve
- 39 Wear Ring, Impeller
- 40 Piston Seal
- 41 Stop Ring, Impeller
- 42 Pump Body
- 43 Motor Adapter Plate (not shown)
- 44 Motor Adapter
- 45 Coupling, Half
- 46 Nut, Tie-Rod
- 47 Tie-Rod
- 48 Washer, Tie-Rod
- 49 Spring, Final Diffuser

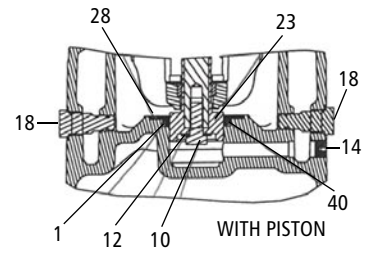
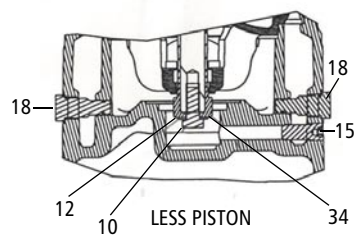

DPS VERSION

FLOW DIRECTION AND MOTOR ROTATION

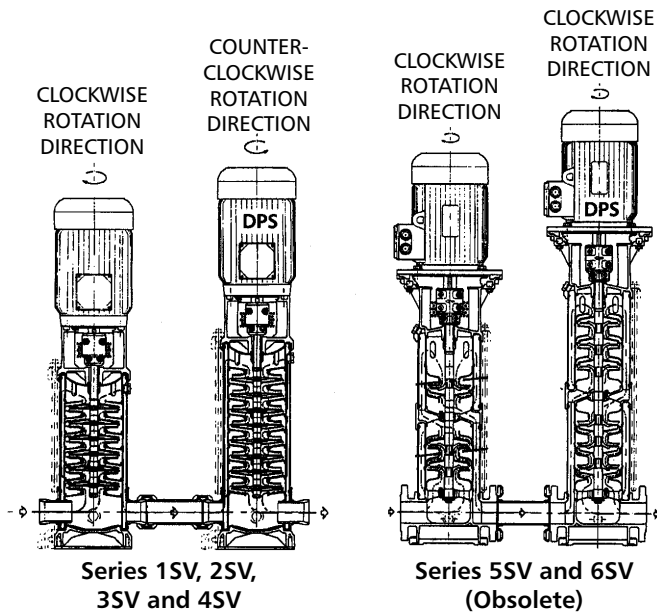

Size	Stage	Motor Rotation
1SV	2-16	CW
	18-22	CCW
1SV DPS	All	CCW
2SV	2-15	CW
	16-22	CCW
2SV DPS	All	CCW
3SV	2-13	CW
	14-16	CCW
3SV DPS	All	CCW
4SV	2-10	CW
	12	CCW
4SV DPS	All	CCW

Refer to the above diagram for proper pump installation detailing flow direction and motor rotation. All DPS units will be properly tagged with flow direction and motor rotation labels. Please ignore all cast direction arrows. Note that the DPS pump is the second unit after the lead SSV unit.

GOULDS PUMPS LIMITED WARRANTY

This warranty applies to all water systems pumps manufactured by Goulds Pumps.

Any part or parts found to be defective within the warranty period shall be replaced at no charge to the dealer during the warranty period. The warranty period shall exist for a period of twelve (12) months from date of installation or eighteen (18) months from date of manufacture, whichever period is shorter.

A dealer who believes that a warranty claim exists must contact the authorized Goulds Pumps distributor from whom the pump was purchased and furnish complete details regarding the claim. The distributor is authorized to adjust any warranty claims utilizing the Goulds Pumps Customer Service Department.

The warranty excludes:

- (a) Labor, transportation and related costs incurred by the dealer;
- (b) Reinstallation costs of repaired equipment;
- (c) Reinstallation costs of replacement equipment;
- (d) Consequential damages of any kind; and,
- (e) Reimbursement for loss caused by interruption of service.

For purposes of this warranty, the following terms have these definitions:

- (1) "Distributor" means any individual, partnership, corporation, association, or other legal relationship that stands between Goulds Pumps and the dealer in purchases, consignments or contracts for sale of the subject pumps.
- (2) "Dealer" means any individual, partnership, corporation, association, or other legal relationship which engages in the business of selling or leasing pumps to customers.
- (3) "Customer" means any entity who buys or leases the subject pumps from a dealer. The "customer" may mean an individual, partnership, corporation, limited liability company, association or other legal entity which may engage in any type of business.

THIS WARRANTY EXTENDS TO THE DEALER ONLY.

Goulds Pumps is a brand of ITT Water Technology, Inc.
- a subsidiary of ITT Industries, Inc.

Goulds Pumps, G&L Pumps and the ITT Engineered Blocks Symbol are registered trademarks and tradenames of ITT Industries.