

SSV SERIES

Vertical Multi-Stage Pumps



A FULL RANGE OF PRODUCT FEATURES

The SSV series of vertical multi-stage pumps from G&L has been designed with exclusive technical benefits to serve the needs of commercial, OEM and HVAC customers.

- Standard NEMA motors permit a wide variety of options and fast field service.
- NPT threads, ANSI flanges, in-line or top/bottom connections easily fit your piping requirements. The top discharge version may be swung in four directions.
- AISI 304 or 316L stainless steel liquid end components handle more of your pumping needs.
- Seal housing design promotes liquid flow and eliminates entrapped air or heat which could cause premature failure.
- Impeller O-ring seal produces high pressure and efficiency per stage to keep energy costs down.
- Impeller spacing is automatic for quick installation and reduced wear.
- Simplified design for maximum reliability and faster repair.
- Optional horizontal mounting and victaulic connections are available.
- Dimensionally compatible with other vertical multistage pumps.



TYPICAL APPLICATIONS

The SSV series is designed for use in a wide range of high pressure applications with flow rates up to 300 GPM.

Examples include:

- Circulation of liquids without suspended solids
- Pressure boosting and water supply
- Agricultural and commercial irrigation systems
- Commercial washing systems
- Boiler feed and condensate return
- Water treatment, reverse osmosis and filtration systems
- Circulation of coolants such as glycol
- Pure water (demineralized and deionized) applications
- Circulation of hot and cold water for HVAC installations



BASE MODELS: 1SV, 2SV, 3SV, AND 4SV
MAJOR COMPONENTS

- 1 Standard NEMA vertical motor
- 2 Rigid coupling
- 3 Motor adapter
- 4 Coupling guard
- 5 Stainless steel seal housing
- 6 Mechanical seal
- 7 Stainless steel fill and drain plugs
- 8 Tie-rods
- 9 O-ring
- 10 Stainless steel pump casing
- 11 Stainless steel diffuser
- 12 Stainless steel impeller
- 13 Tungsten carbide shaft sleeve
- 14 Ceramic bushing
- 15 Stainless steel shaft
- 16 Stainless steel pump body
- 17 Pump base

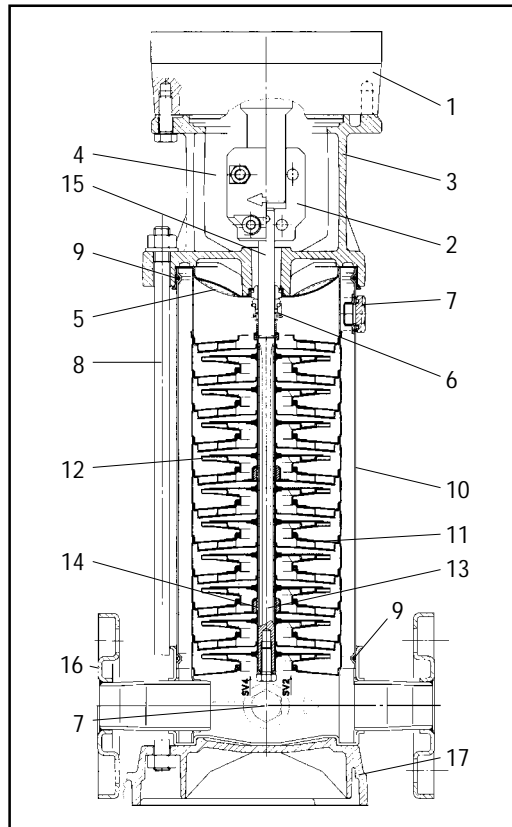

SERIES A



SERIES B OR D



SERIES C



SSV PERFORMANCE CURVES 60 Hz USA

