

Pump End Parts For Close-Coupled or Frame Mounted Configuration

Note: For S-Group power frame individual parts
see S-Group Power Frame repair parts page.

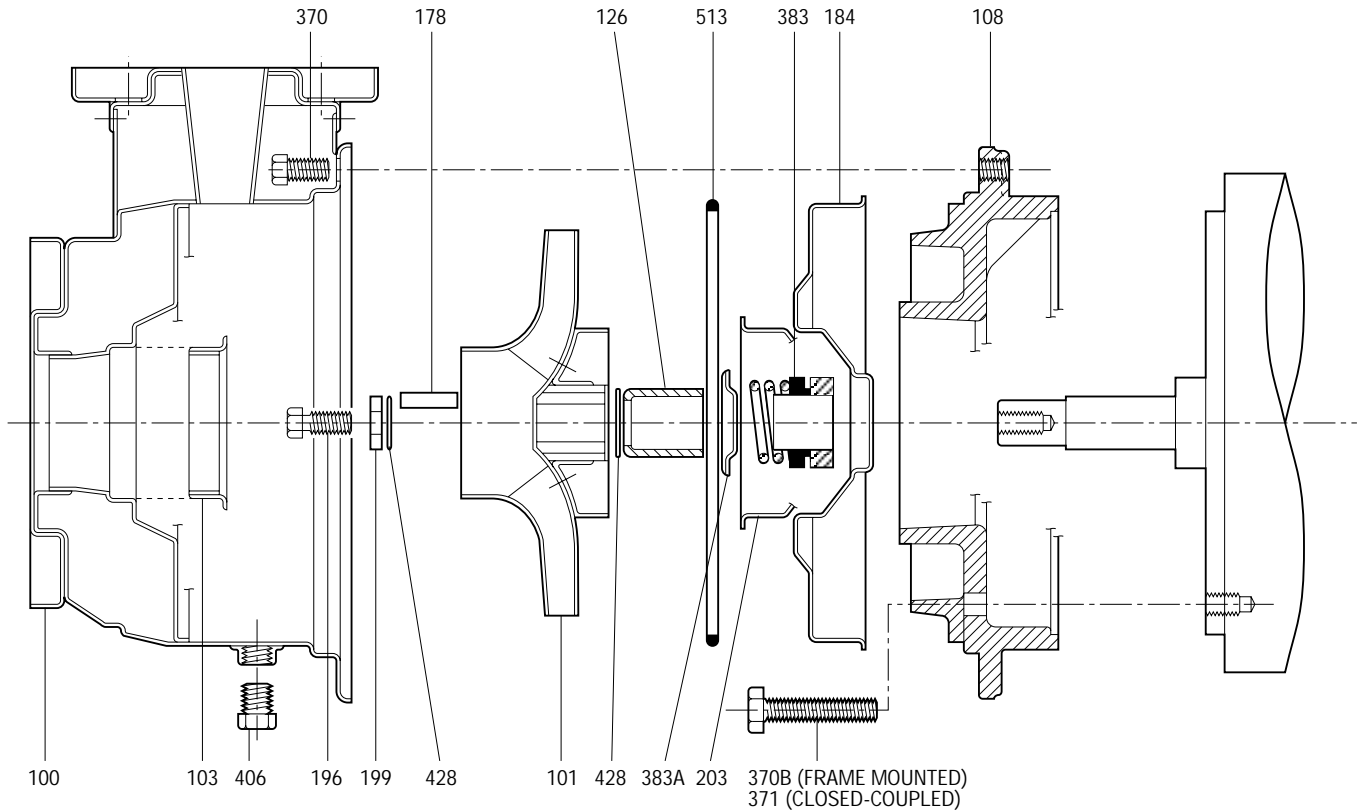

FASTENER SIZING KEY – NOMINAL SIZE/TYPE/LENGTH

13L38	3/8" Socket head x 3/4" lg.
13L40	1/2" Hex head x 2 1/4" lg.
13L41	1/2" Socket head x 1 3/4" lg.
13L43	3/8" Hex head x 2 1/4" lg.
13L86	1/2" Hex head x 1 1/4" lg. with 1/2" nut

Pump End Parts For Close-Coupled or Frame Mounted Configuration

MODEL

Note: For S-Group power frame individual parts see S-Group Power Frame repair parts page.

SST S-Group

Effective September, 1990

Item No.	Part Description	Materials	6" Impellers				8" Impellers			10" Impellers	Max. Wt. lbs.
			1 x 2-6	1 1/4 x 2-6	1 1/2 x 2 1/2-6	2 x 2 1/2-6	1 x 2-8	1 1/4 x 2-8	1 1/2 x 2 1/2-8	1 x 2-10	
			Part No.	Part No.	Part No.	Part No.	Part No.	Part No.	Part No.	Part No.	
100	Casing with wear ring		1L129	1L130	1L231	1L332	1L135	1L136	1L237	1L141	17
101	Impeller	AISI type 304 SS	6 1/2 2L111	6 1/2 2L111	6 1/2 2L211	6 1/2 2L611	7 3/4 2L421	7 3/4 2L421	7 3/4 2L521	10 1/16 2L431	7
			6 5/16 2L113	6 5/16 2L113	6 5/16 2L213	6 5/16 2L613	7 1/2 2L423	7 1/2 2L423	7 1/2 2L523	9 13/16 2L422	
			5 15/16 2L117	6 1/8 2L115	6 1/8 2L215	6 1/8 2L615	6 15/16 2L427	6 15/16 2L427	7 1/4 2L525	9 1/4 2L436	
			5 5/16 2L119	5 15/16 2L117	5 15/16 2L217	5 15/16 2L617	6 1/2 2L111	6 1/2 2L111	7 1/8 2L527	8 7/8 2L433	
			4 15/16 2L104	5 5/16 2L119	5 5/16 2L219	5 1/2 2L619	5 15/16 2L617	6 5/16 2L113	6 3/4 2L529	8 1/4 2L437	
			4 5/16 2L102	5 5/16 2L101	5 5/8 2L201	5 5/16 2L301	5 5/16 2L119	6 1/8 2L115		7 7/8 2L435	
			4 3/8 2L103	4 5/16 2L102	4 15/16 2L202	5 1/8 2L303				7 3/4 2L421	
				4 3/8 2L103	4 3/4 2L203	4 5/16 2L305					
		4 5/16 2L204	4 5/16 2L307								
103	Wear ring, casing		4L101		4L102	4L103	4L101		4L102	4L101	-
184	Seal housing (includes wear ring as noted)		1L104 without wear ring			1L106 with wear ring	1L106 with wear ring		1L115 with wear ring	3	
203	Wear ring, seal housing		none			4L201				-	
126	Shaft sleeve		4K66								-
178	Impeller key		4K11								-
196	Impeller bolt	AISI type 300 SS	13K43								-
199	Impeller washer		13L39								-
106	Adapter for close-coupled (104JM-180JM) and S-group power frame	Cast iron ASTM A48 CL20	1L50				1L52			1L97	25
	Adapter for close-coupled (210JM-250JM motors)		1L51				1L53			1L96	29
370	Casing bolting (8) required	AISI type 300 SS	13L38							13L86	-
371	Adapter bolt (4) required for close-coupled	Carbon steel SAE 1200 series	13L43 (with 1L50, 1L52, 1L97 adapters)								-
370B	Adapter bolt for frame mounted		13L41 (with 1L51, 1L53, 1L96 adapters)								-
383	Mechanical seal standard duty	Carbon/ceramic	10K13								1/2
	Mechanical seal high temperature	Carbon/Ni-resist	10K19								
	Mechanical seal chemical duty	Carbon/ceramic	10K25								
	Mechanical seal severe duty/high temp.	Carbon/tung. carb.	10K27								
383A	Seal spring retainer	AISI type 300 SS	4L45 (replace with mechanical seal assembly)								-
408	Drain plug 3/8" plug		13L42								-
428	Impeller gasket set	Mylar	5L73								-
513	O-ring - casing	BUNA-N	5L40				5L41			5L69	-
	O-ring - casing (optional)	Viton	5L42				5L43			5L71	-

NOTE: For pricing refer to published Parts Price List using "L" or "K" number above.