

SFH

SFH Series
End Suction
Centrifugal
Pumps

*Bombas serie
SFH centrífugas
de extremo
de succión*

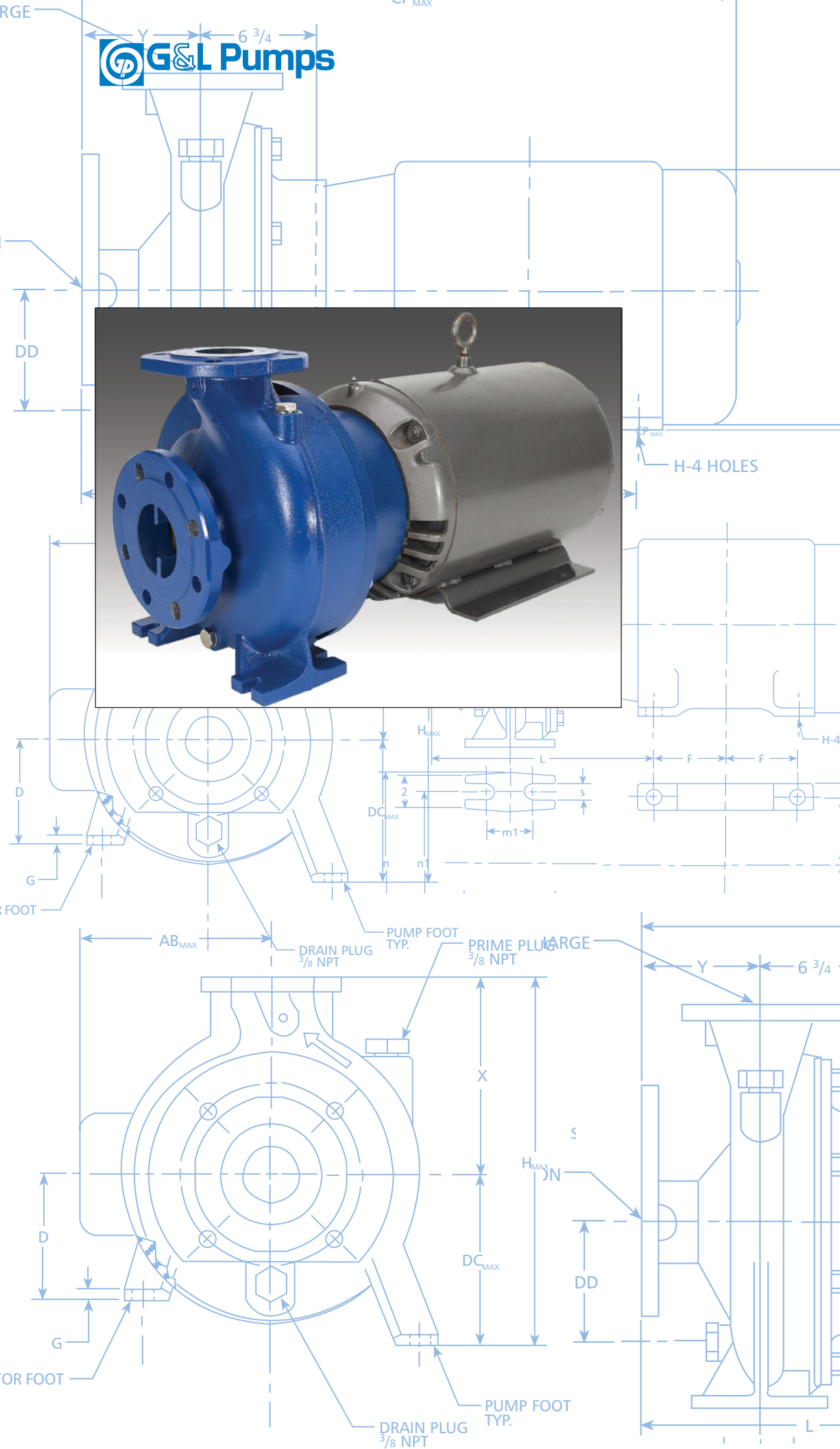

A Full Range of Product Features, Una gama completa de características del producto

Superior Materials of Construction:

AISI Type 316L stainless steel impellers (S-group); cast iron impeller (M-group) with rugged cast iron casings and seal housings provide reliable performance.

Close-Coupled Design:

Compact design saves space and simplifies maintenance.

Back Pull-Out Design:

Simplifies maintenance when used with spacer type coupling.

Mechanical Seal: Standard John Crane Type 21 mechanical seal.

Drive Motors: Standard NEMA design JP motors in single or three phase.

Suction and Discharge Flanges:

Mate with ANSI class 125/150 flanges.

Materiales superiores de construcción:

Los impulsores de acero inoxidable AISI tipo 316L (Grupo S); impulsor de hierro fundido (Grupo M) con carcasas de hierro fundido y cajas para sello resistentes ofrecen un rendimiento confiable.

Diseño de acoplamiento compacto:

El diseño compacto ahorra espacio y simplifica el mantenimiento.

Diseño de extracción trasera:

Simplifica el mantenimiento cuando se usa con el acoplamiento tipo espaciador.

Sello mecánico: Sello mecánico estándar John Crane Tipo 21.

Motores de accionamiento: Motores JP de diseño NEMA estándar monofásicos o trifásicos.

Bridas de succión y descarga: Acoplan con bridas ANSI clase 125/150.

Performance Coverage, 3500 and 1750 RPM Alcance de funcionamiento, 3500 y 1750 RPM

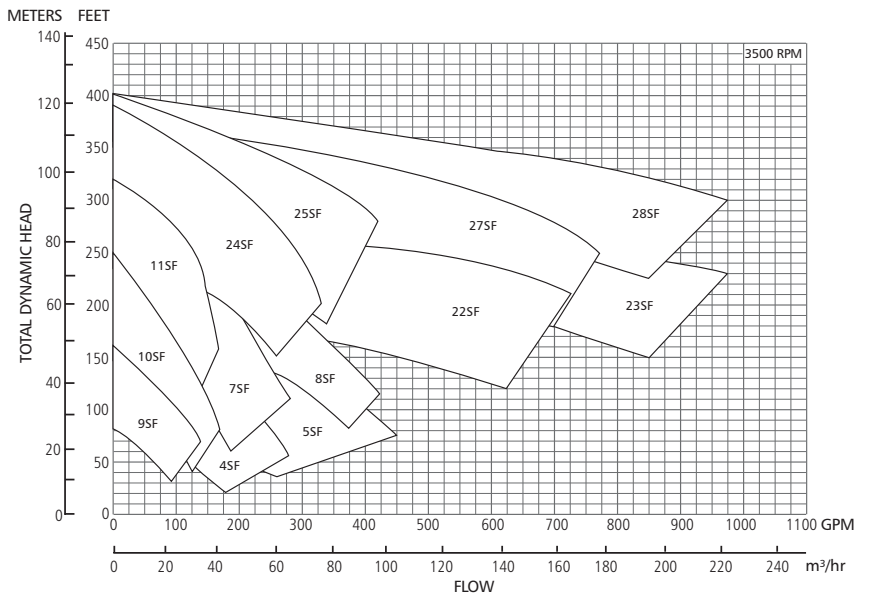
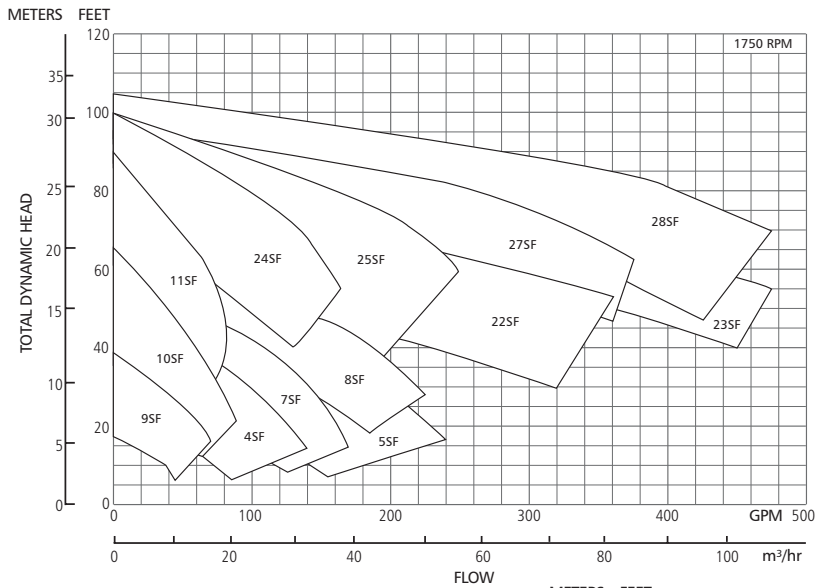

SFH-C Numbering System

Sistema de numeración del grupo SFH-C

Example Product Code, Ejemplo código del producto

4 SF 1 L 3 A 0

Mechanical Seal and O-Ring

0 = Standard

For optional Mechanical Seal modify catalog order no. with Seal Code listed below.

Sello mecánico y anillo-0

0 = Estándar

Para sello mecánico opcional modificar el número de orden del catálogo con el código del sello que se presenta abajo.

John Crane Type 21 Mechanical Seal, Sello mecánico John Crane tipo 21						
Seal Code, Código del Sello	Rotary, Rotativo	Stationary, Estacionario	Elastomers, Elastómeros	Metal Parts, Partes metálicas	Part No., Pieza número	
					140-180, 210TCZ 1/8 shaft (eje) Ø	210-280, 360TCZ 1 1/4 shaft (eje) Ø
0	Carbon, Carbón	Ceramic, Cerámica	BUNA	316 SS, Acero inoxidable 316	10K13	10K16
2		Sil-Carbide, Carburo de silicio	EPR		10K19	10K20
4		Sil-Carbide	Viton		10K27	10K45
5	10K64				10K65	

Impeller Option Code

For optional impeller diameters modify catalog no. with impeller code listed below.

Select optional impeller diameter from pump performance curve.

Código de opción del impulsor

Para diámetros opcionales de impulsor modificar el número de orden del catálogo con el código del impulsor enumerado abajo.

Seleccionar el diámetro del impulsor de la curva característica de la bomba.

Impeller Code, Código del impulsor	Diameter, Diámetro												
	9SF 1 1/4 x 2-6	10SF 1 1/4 x 2-8	11SF 1 1/2 x 2-10	4SF 1 1/2 x 2 1/2-6	7SF 1 1/2 x 2 1/2-8	5SF 2 x 2 1/2-6	8SF 2 x 2 1/2-8	24SF 1 1/2 x 2-10	25SF 2 x 2 1/2-10	22SF 2 1/2 x 3-8	23SF 3 x 4-8	27SF 2 1/2 x 3-10	28SF 3 x 4-10
A	6 3/8	8 1/16	10 3/32	6 3/4	8 1/4	6 7/8	8 1/4*	9 7/8	9 7/8	8 1/2	8 11/32	9 3/4	9 9/16
B	6 7/16	7 11/16	9 11/32	6 3/8	7 13/16	6 7/16	7 3/4	9 1/2	9 1/2	8 3/8	8 1/4	9 3/8	9 3/8
C	5 11/16	7 3/8	9 1/8	6 1/16	7	5 13/16	7 1/2	9 3/16	9 3/8	8 3/32	8	9 3/16	8 7/8
D	5 3/8	7 1/8	8 3/4	5 5/8	6 3/4	5 1/2	7 1/16	8 3/8	8 3/16	7 7/8	7 1/4	8 13/16	8 7/16
E	4 3/4	6 7/16		5 5/16	6 1/16	5 1/8	6 1/8	8 3/16	8 3/16	7 1/2	7 1/4	8 5/8	8 1/4
F	4 9/16	6 1/8		4 11/16	6 1/8	4 13/16		8 1/4	7 15/16				
G				4 3/16		4 1/16				6 3/4			

* 1750 RPM Only, Solamente 1750 RPM

Driver, Fuerza motriz

1 = 1 PH, fase, ODP 6 = 575 V, TEFC
 2 = 3 PH, fases, ODP 7 = 3 PH, fases, XP
 3 = 575 V, ODP 8 = 575 V, XP
 4 = 1 PH, fase, TEFC 9 = 3 PH, fases, TEFC (1.25 S.F., Factor de servicio de 1.25)
 5 = 3 PH, fases, TEFC 0 = 1 PH, fase, XP

HP Rating, HP potencia

C = 1/2 HP G = 2 HP L = 10 HP Q = 30 HP U = 75 HP
 D = 3/4 HP H = 3 HP M = 15 HP R = 40 HP V = 100 HP
 E = 1 HP J = 5 HP N = 20 HP S = 50 HP
 F = 1 1/2 HP K = 7 1/2 HP P = 25 HP T = 60 HP

Driver: Hertz/Pole/RPM, Motor: hertzios/polo/RPM

1 = 60 Hz, 2 pole, 3500 RPM
 2 = 60 Hz, 4 pole, 1750 RPM
 3 = 60 Hz, 6 pole, 1150 RPM
 4 = 50 Hz, 2 pole, 2900 RPM
 5 = 50 Hz, 4 pole, 1450 RPM

Material

SF = Cast iron casing, 316L stainless steel impeller. Cast iron impellers on sizes (22, 23, 27, 28).

SF = Carcasa de hierro fundido, impulsor de acero inoxidable, 316L. Impulsores de hierro fundido en tamaños (22, 23, 27, 28).

Pump Size, Tamaño de la bomba

9 = 1 1/4 x 2 - 6 7 = 1 1/2 x 2 1/2 - 8 24 = 1 1/2 x 2 - 10 23 = 3 x 4 - 8
 10 = 1 1/4 x 2 - 8 5 = 2 x 2 1/2 - 6 25 = 1 1/2 x 2 1/2 - 10 27 = 2 1/2 x 3 - 10
 4 = 1 1/2 x 2 1/2 - 6 8 = 2 x 2 1/2 - 8 22 = 2 1/2 x 3 - 8 28 = 3 x 4 - 10
 11 = 1 1/2 x 2 - 10

For frame mounted pumps substitute the letters "FRM".

Para bombas con armazón montado sustituya las letras "FRM".

NOTE: Not all combinations of motor, impeller and seal options are available for every pump model. Please check with G&L on non-cataloged numbers.

NOTA: No todas las combinaciones de las opciones de motor, impulsor y sello están disponibles para cada modelo de bombas. Por favor verifique con G&L en los números no catalogados.

Performance Curves – S-Group, 60 Hz, 3500 RPM
Curvas de funcionamiento – Grupo S, 60 Hz, 3500 RPM

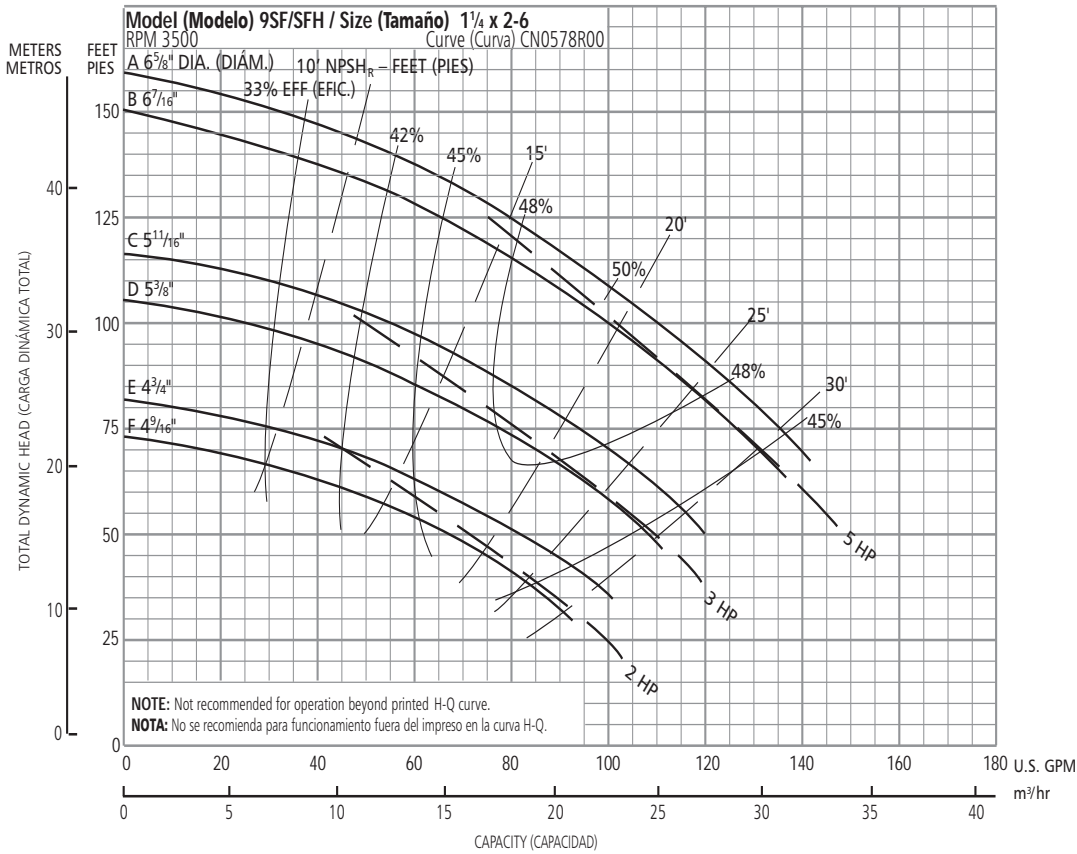

Optional Impeller, Impulsor opcional		
Impeller Code, Código del impulsor	Dia., Diám.	Motor HP, HP del motor
A	6 5/8"	5
B	6 7/16"	5
C	5 11/16"	3
D	5 3/8"	3
E	4 3/4"	2
F	4 9/16"	2

NOTE: Pump will pass a sphere to 1/8" diameter.

NOTA: La bomba pasará una esfera a 1/8" diámetro.

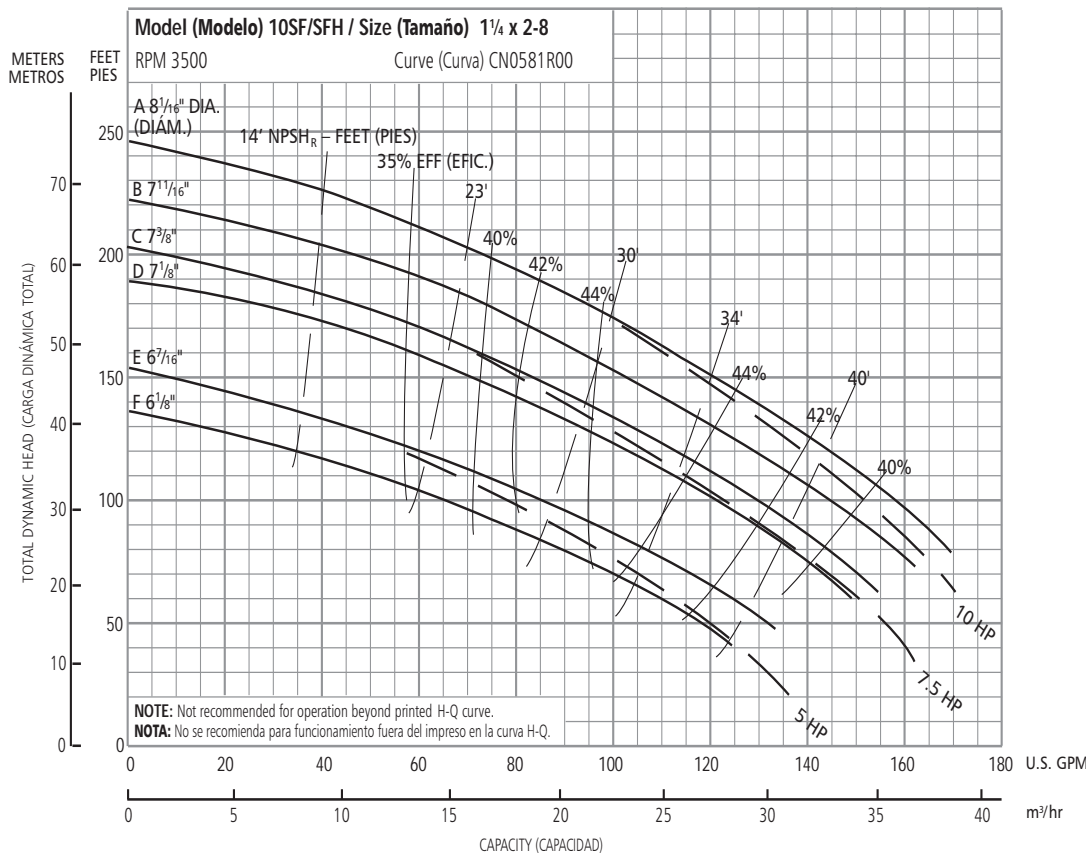

Optional Impeller, Impulsor opcional		
Impeller Code, Código del impulsor	Dia., Diám.	Motor HP, HP del motor
A	8 1/16"	10
B	7 11/16"	10
C	7 3/8"	7 1/2
D	7 1/8"	7 1/2
E	6 7/16"	5
F	6 1/8"	5

NOTE: Pump will pass a sphere to 1/8" diameter.

NOTA: La bomba pasará una esfera a 1/8" diámetro.

Performance Curves – S-Group, 60 Hz, 3500 RPM
Curvas de funcionamiento – Grupo S, 60 Hz, 3500 RPM

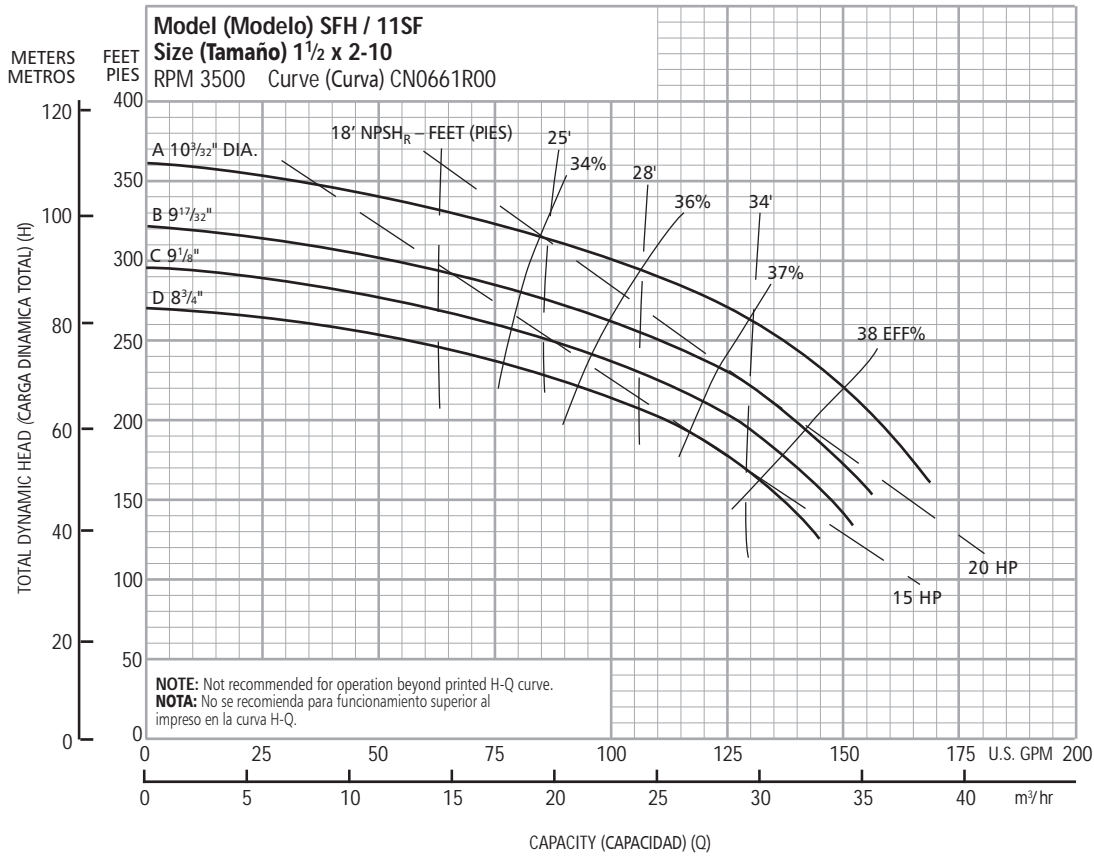

Optional Impeller, Impulsor opcional		
Impeller Code, Código del impulsor	Dia., Diám.	Motor HP, HP del motor
A	10 ³ / ₃₂ "	20
B	9 ¹⁷ / ₃₂ "	20
C	9 ¹ / ₈ "	15
D	8 ³ / ₄ "	15

NOTE: Pump will pass a sphere to 3/16" diameter.
NOTA: La bomba pasará una esfera a 3/16" diámetro.

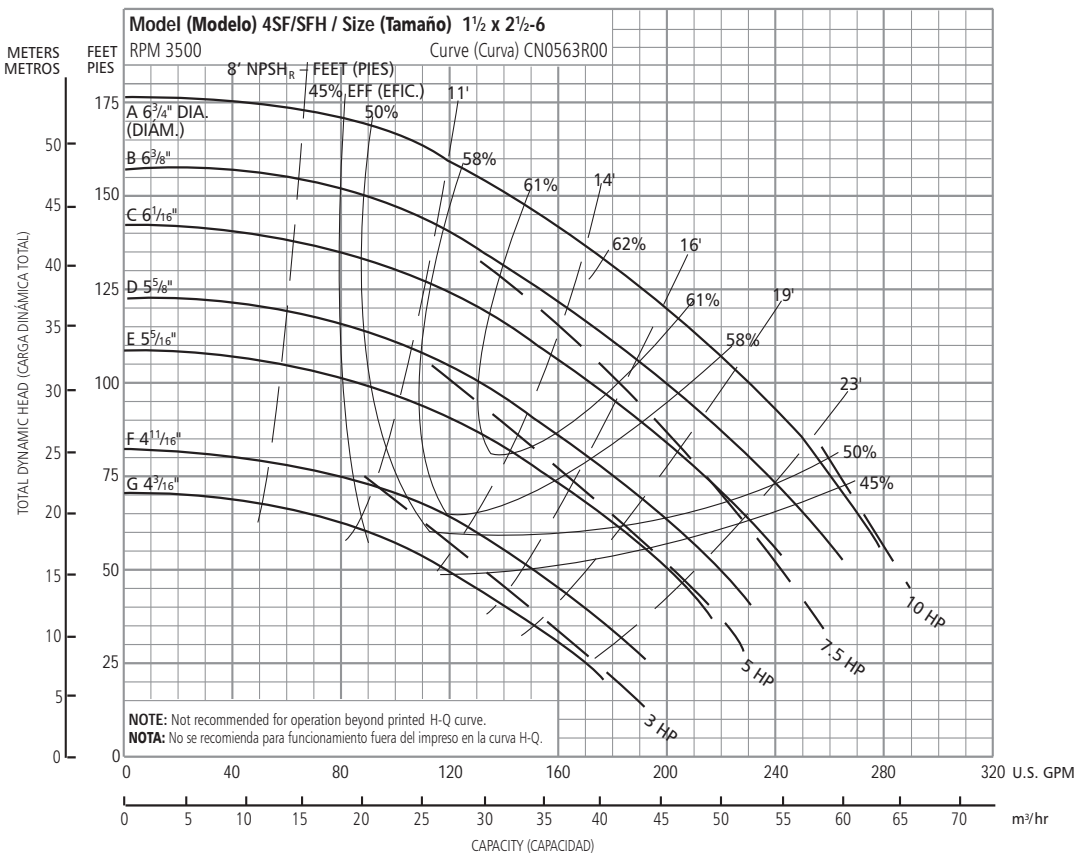

Optional Impeller, Impulsor opcional		
Impeller Code, Código del impulsor	Dia., Diám.	Motor HP, HP del motor
A	6 ³ / ₄ "	10
B	6 ³ / ₈ "	7½
C	6 ¹ / ₁₆ "	7½
D	5 ⁵ / ₈ "	5
E	5 ⁵ / ₁₆ "	5
F	4 ¹¹ / ₁₆ "	3
G	4 ³ / ₁₆ "	3

NOTE: Pump will pass a sphere to 3/16" diameter.
NOTA: La bomba pasará una esfera a 3/16" diámetro.

Performance Curves – S-Group, 60 Hz, 3500 RPM
Curvas de funcionamiento – Grupo S, 60 Hz, 3500 RPM

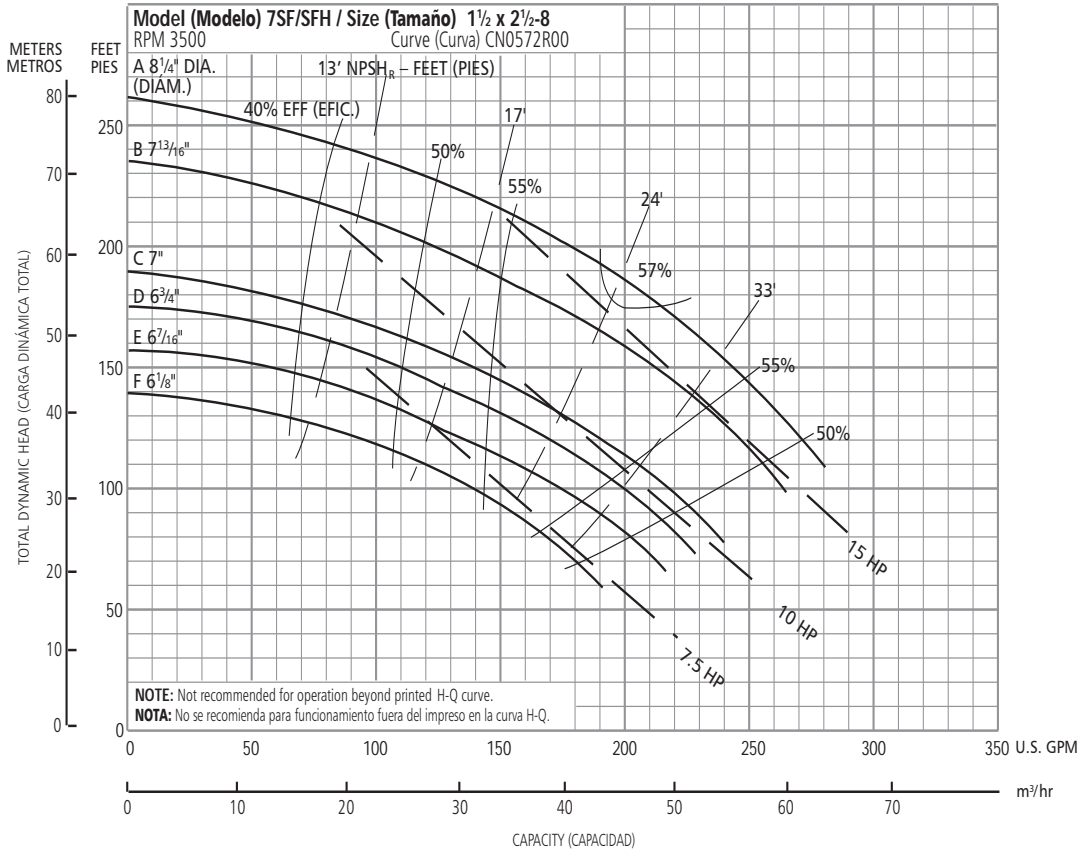

Optional Impeller, Impulsor opcional		
Impeller Code, Código del impulsor	Dia., Diám.	Motor HP, HP del motor
A	8 3/4"	15
B	7 13/16"	15
C	7	10
D	6 3/4"	10
E	6 7/16"	7 1/2
F	6 1/8"	7 1/2

NOTE: Pump will pass a sphere to 3/16" diameter.

NOTA: La bomba pasará una esfera a 3/16" diámetro.

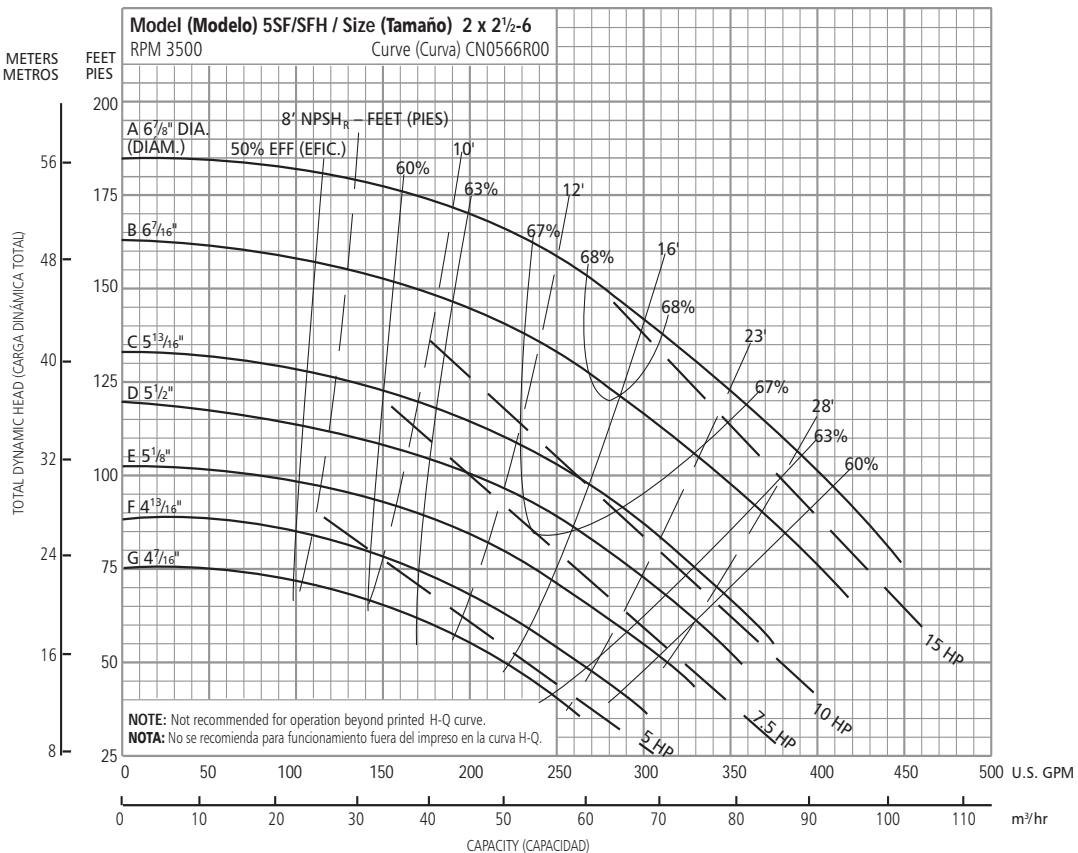

Optional Impeller, Impulsor opcional		
Impeller Code, Código del impulsor	Dia., Diám.	Motor HP, HP del motor
A	6 7/8"	15
B	6 7/16"	15
C	5 13/16"	10
D	5 1/2"	7 1/2
E	5 1/8"	7 1/2
F	4 13/16"	5
G	4 7/16"	5

NOTE: Pump will pass a sphere to 5/32" diameter.

NOTA: La bomba pasará una esfera a 5/32" diámetro.

Performance Curves – S-Group, 60 Hz, 3500 RPM
Curvas de funcionamiento – Grupo S, 60 Hz, 3500 RPM

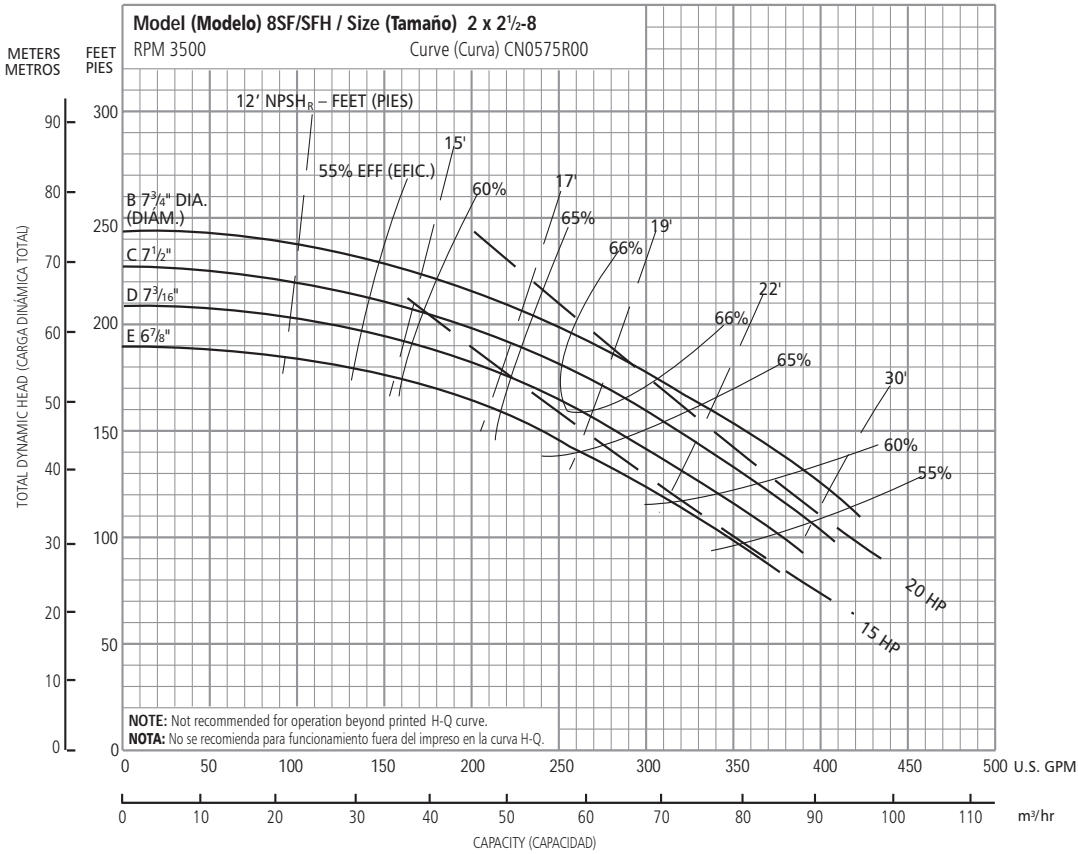

Optional Impeller, Impulsor opcional		
Impeller Code, Código del impulsor	Dia., Diám.	Motor HP, HP del motor
B	7¾"	20
C	7½"	20
D	7¾"	15
E	6⅞"	15

NOTE: Pump will pass a sphere to 5/32" diameter.

NOTA: La bomba pasará una esfera a 5/32" diámetro.

Performance Curves – M-Group, 60 Hz, 3500 RPM
Curvas de funcionamiento – Grupo M, 60 Hz, 3500 RPM

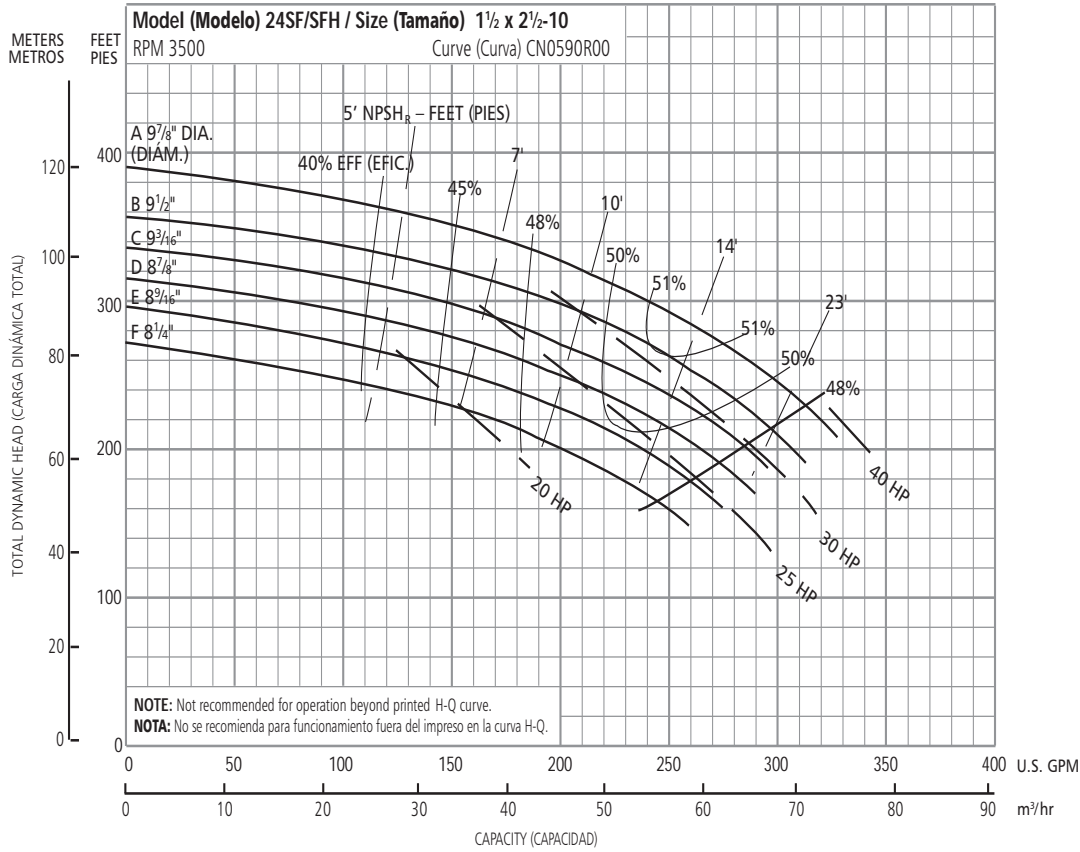

Optional Impeller, Impulsor opcional		
Impeller Code, Código del impulsor	Dia., Diám.	Motor HP, HP del motor
A	9 7/8"	40
B	9 1/2"	30
C	9 3/16"	30
D	8 7/8"	25
E	8 9/16"	25
F	8 1/4"	20

NOTE: Pump will pass a sphere to 5/16" diameter.

NOTA: La bomba pasará una esfera a 5/16" diámetro.

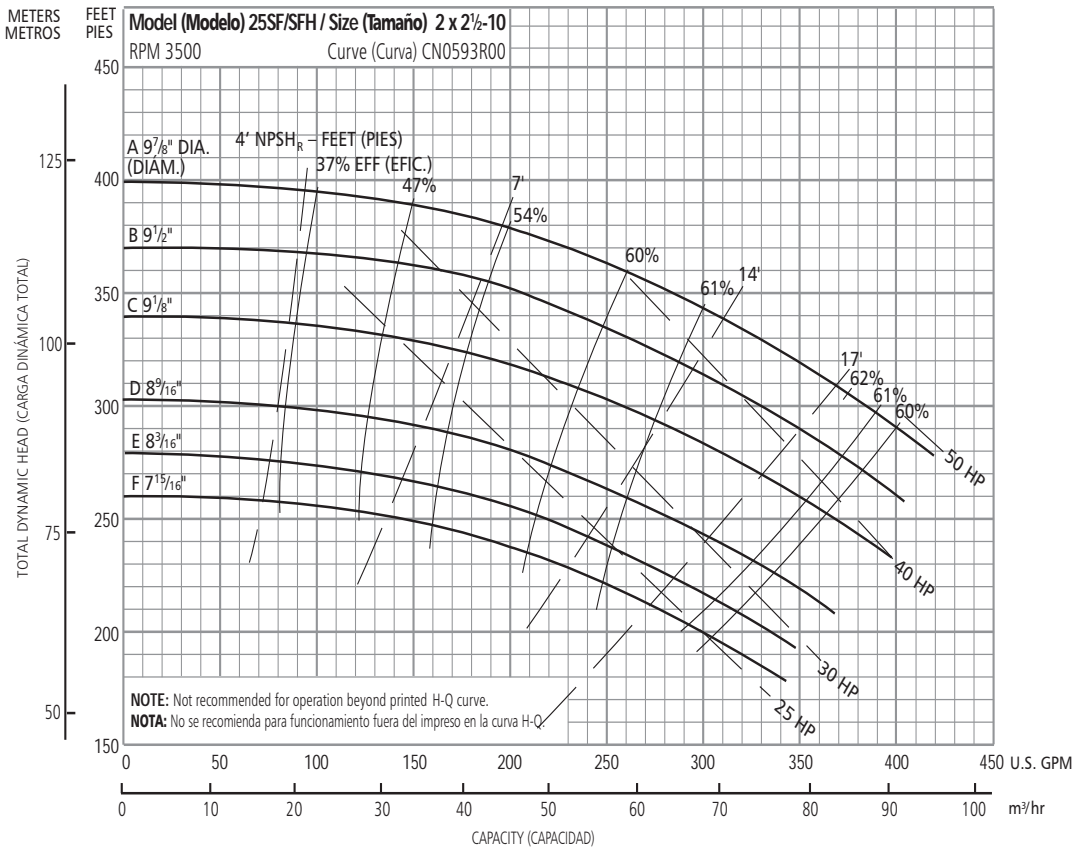

Optional Impeller, Impulsor opcional		
Impeller Code, Código del impulsor	Dia., Diám.	Motor HP, HP del motor
A	9 7/8"	50
B	9 1/2"	40
C	9 1/8"	40
D	8 9/16"	30
E	8 3/16"	30
F	7 15/16"	25

NOTE: Pump will pass a sphere to 1/2" diameter.

NOTA: La bomba pasará una esfera a 1/2" diámetro.

Performance Curves – M-Group, 60 Hz, 3500 RPM
Curvas de funcionamiento – Grupo M, 60 Hz, 3500 RPM

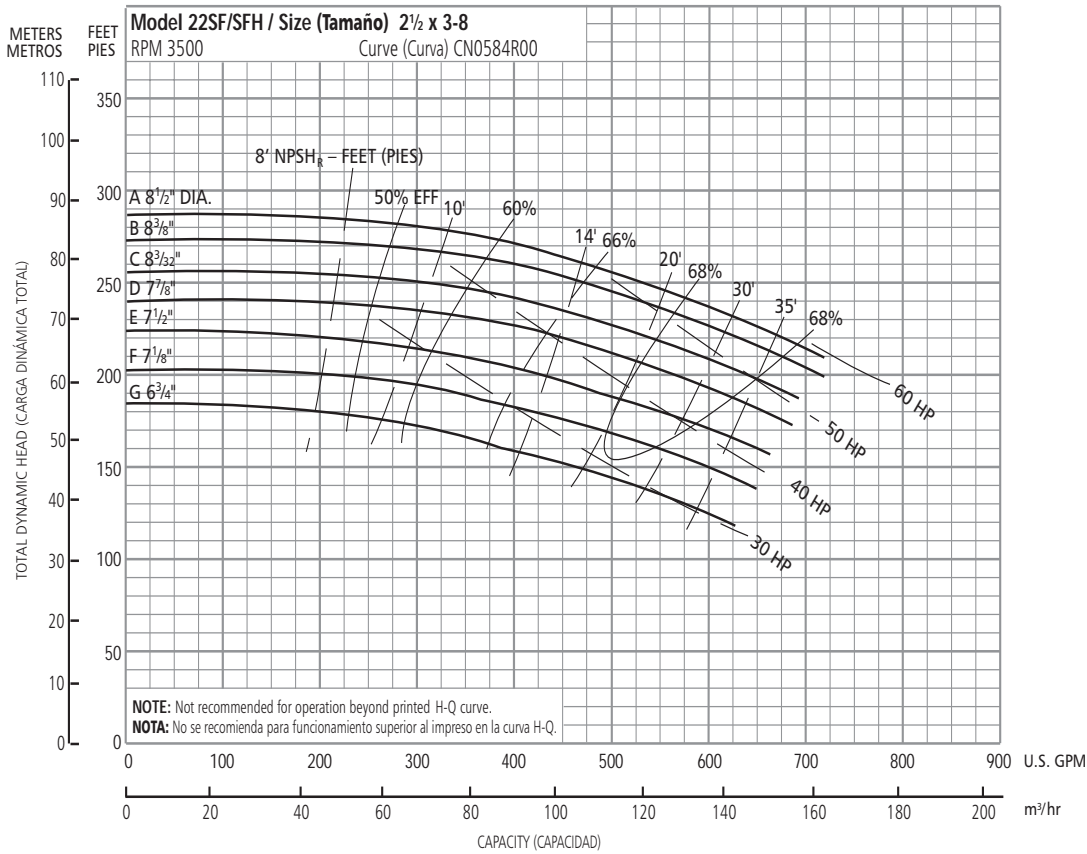

Optional Impeller, Impulsor opcional		
Impeller Code, Código del impulsor	Dia., Diám.	Motor HP, HP del motor
A	8 1/2"	60
B	8 3/8"	50
C	8 3/32"	50
D	7 7/8"	40
E	7 1/2"	40
F	7 1/8"	30
G	6 3/4"	30

NOTE: Pump will pass a sphere to 5/32" diameter.

NOTA: La bomba pasará una esfera a 5/32" diámetro.

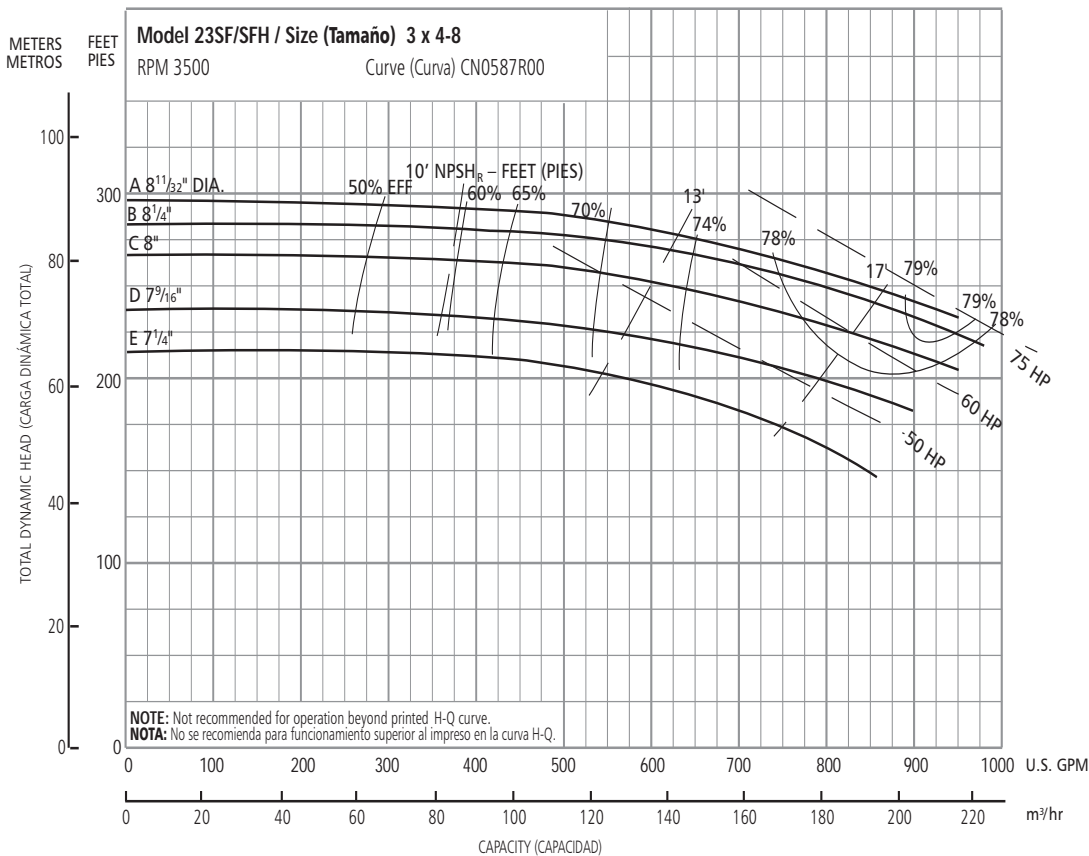

Optional Impeller, Impulsor opcional		
Impeller Code, Código del impulsor	Dia., Diám.	Motor HP, HP del motor
A	8 11/32"	75
B	8 1/4"	60
C	8"	60
D	7 9/16"	50
E	7 1/4"	50

NOTE: Pump will pass a sphere to 5/32" diameter.

NOTA: La bomba pasará una esfera a 5/32" diámetro.

Performance Curves – M-Group, 60 Hz, 3500 RPM
Curvas de funcionamiento – Grupo M, 60 Hz, 3500 RPM

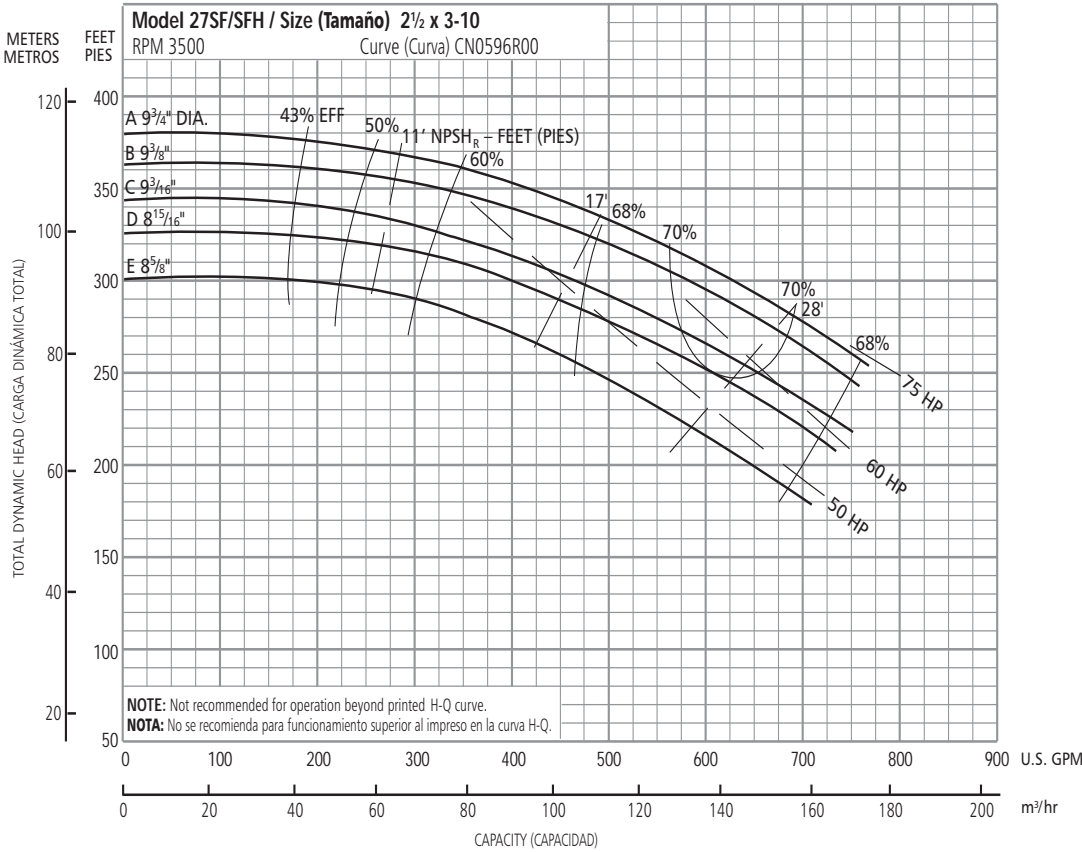

Optional Impeller, Impulsor opcional		
Impeller Code, Código del impulsor	Dia., Diám.	Motor HP, HP del motor
A	9 3/4"	75
B	9 3/8"	60
C	9 3/16"	60
D	8 15/16"	50
E	8 5/8"	50

NOTE: Pump will pass a sphere to 5/16" diameter.

NOTA: La bomba pasará una esfera a 5/16" diámetro.

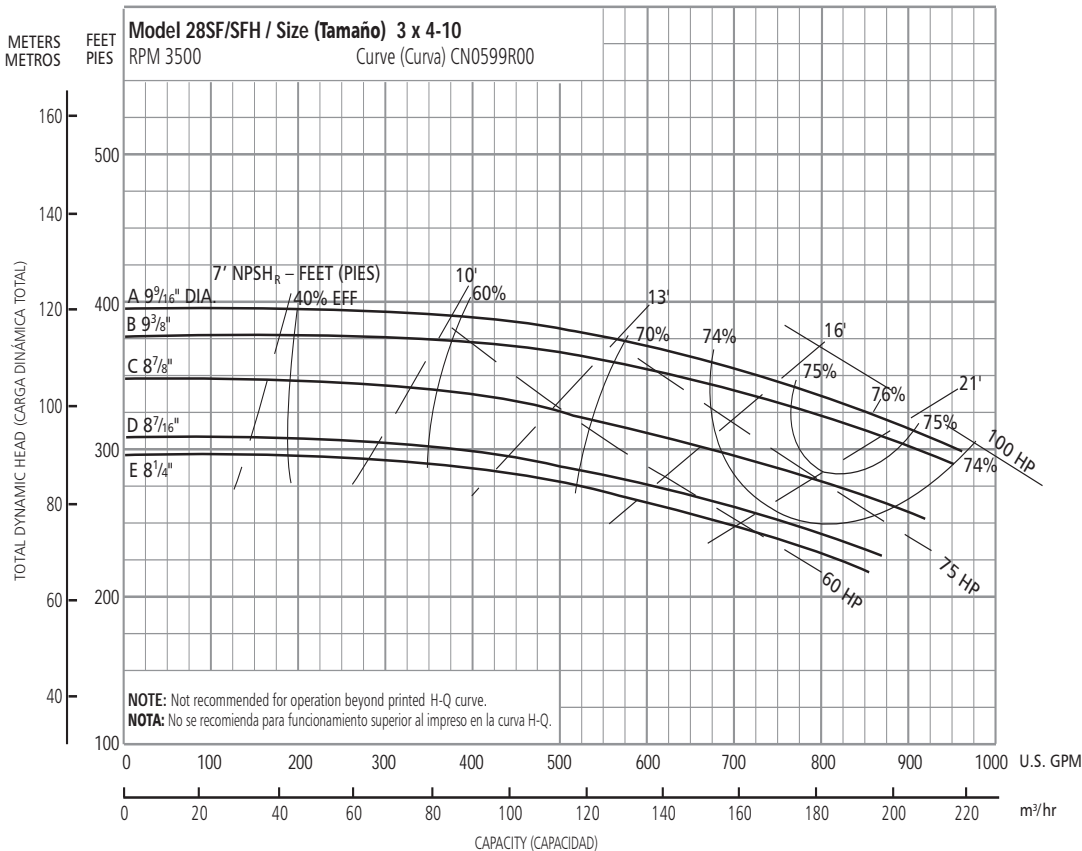

Optional Impeller, Impulsor opcional		
Impeller Code, Código del impulsor	Dia., Diám.	Motor HP, HP del motor
A	9 9/16"	100
B	9 3/8"	75
C	8 7/8"	75
D	8 7/16"	60
E	8 1/4"	60

NOTE: Pump will pass a sphere to 1/2" diameter.

NOTA: La bomba pasará una esfera a 1/2" diámetro.

Performance Curves – S-Group, 60 Hz, 1750 RPM
Curvas de funcionamiento – Grupo S, 60 Hz, 1750 RPM

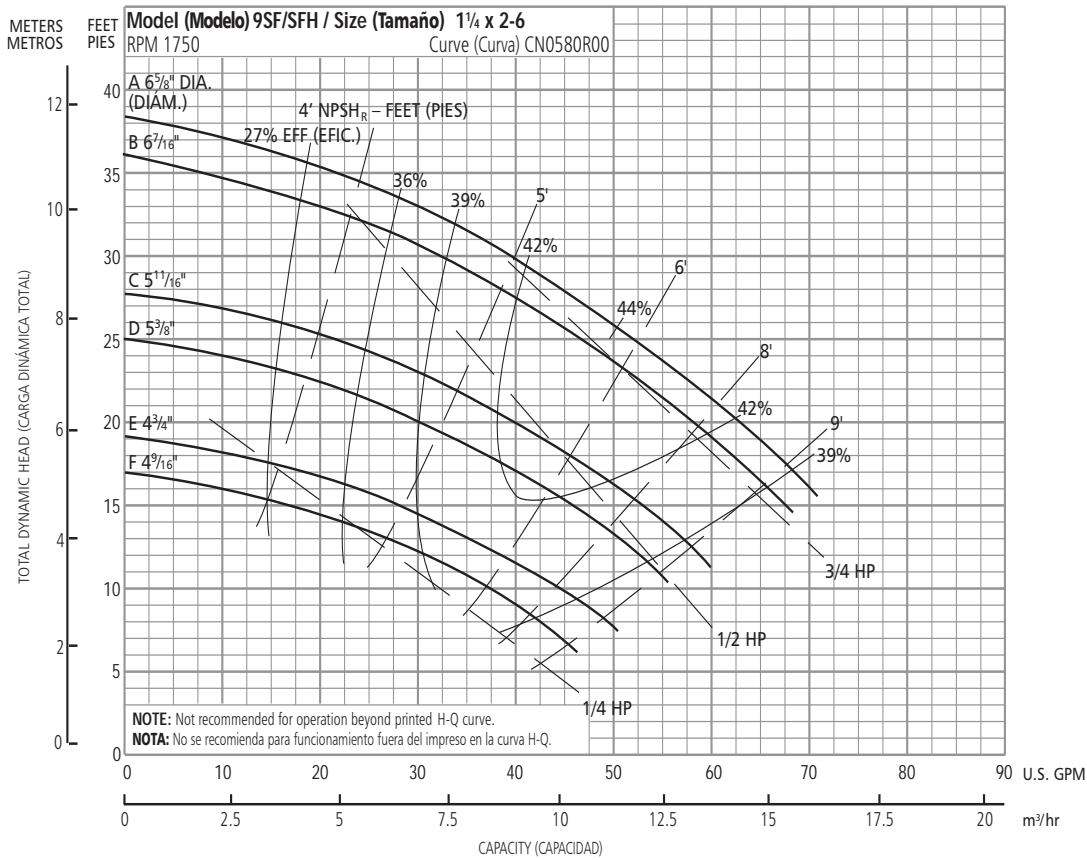

Optional Impeller, Impulsor opcional		
Impeller Code, Código del impulsor	Dia., Diám.	Motor HP, HP del motor
A	6 ⁵ / ₈ "	¾
B	6 ⁷ / ₁₆ "	¾
C	5 ¹¹ / ₁₆ "	½
D	5 ³ / ₈ "	½
E	4 ³ / ₄ "	½
F	4 ⁹ / ₁₆ "	½

NOTE: Pump will pass a sphere to 1/8" diameter.

NOTA: La bomba pasará una esfera a 1/8" diámetro.

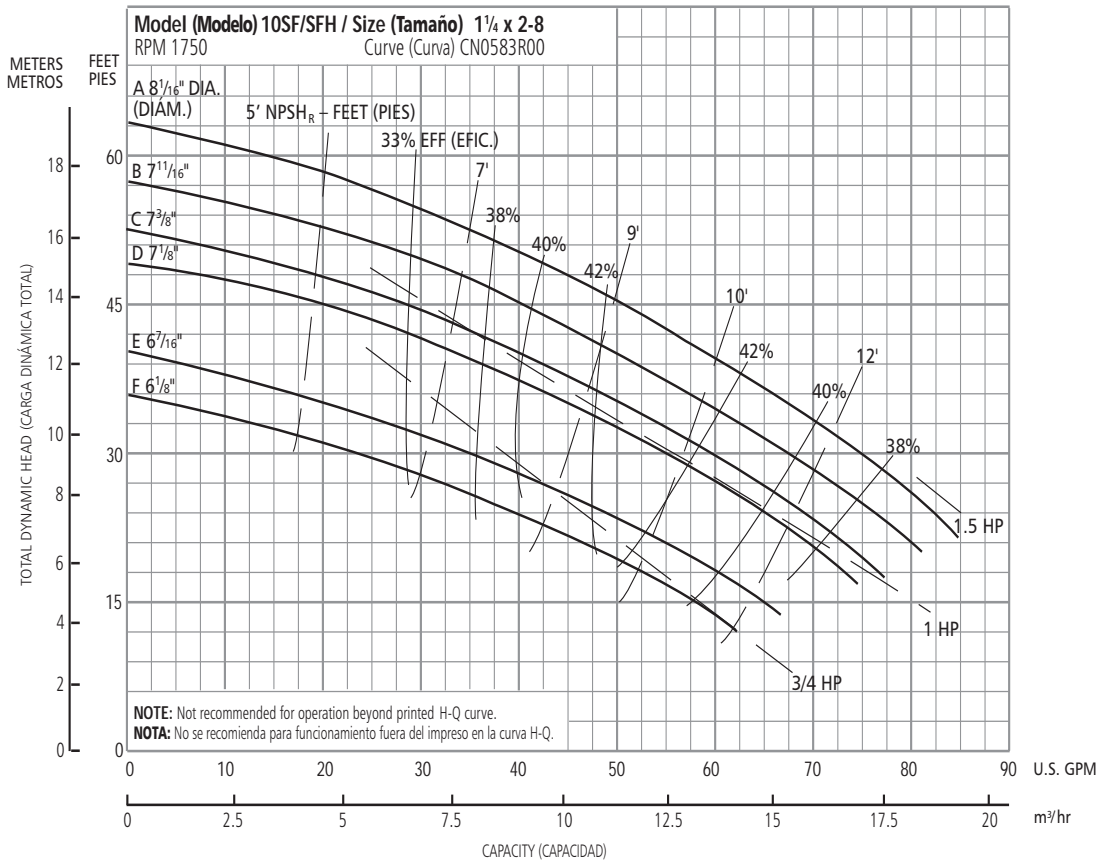

Optional Impeller, Impulsor opcional		
Impeller Code, Código del impulsor	Dia., Diám.	Motor HP, HP del motor
A	8 ¹ / ₁₆ "	1½
B	7 ¹¹ / ₁₆ "	1½
C	7 ³ / ₈ "	1
D	7 ¹ / ₈ "	1
E	6 ⁷ / ₁₆ "	¾
F	6 ¹ / ₈ "	¾

NOTE: Pump will pass a sphere to 1/8" diameter.

NOTA: La bomba pasará una esfera a 1/8" diámetro.

Performance Curves – S-Group, 60 Hz, 1750 RPM
Curvas de funcionamiento – Grupo S, 60 Hz, 1750 RPM

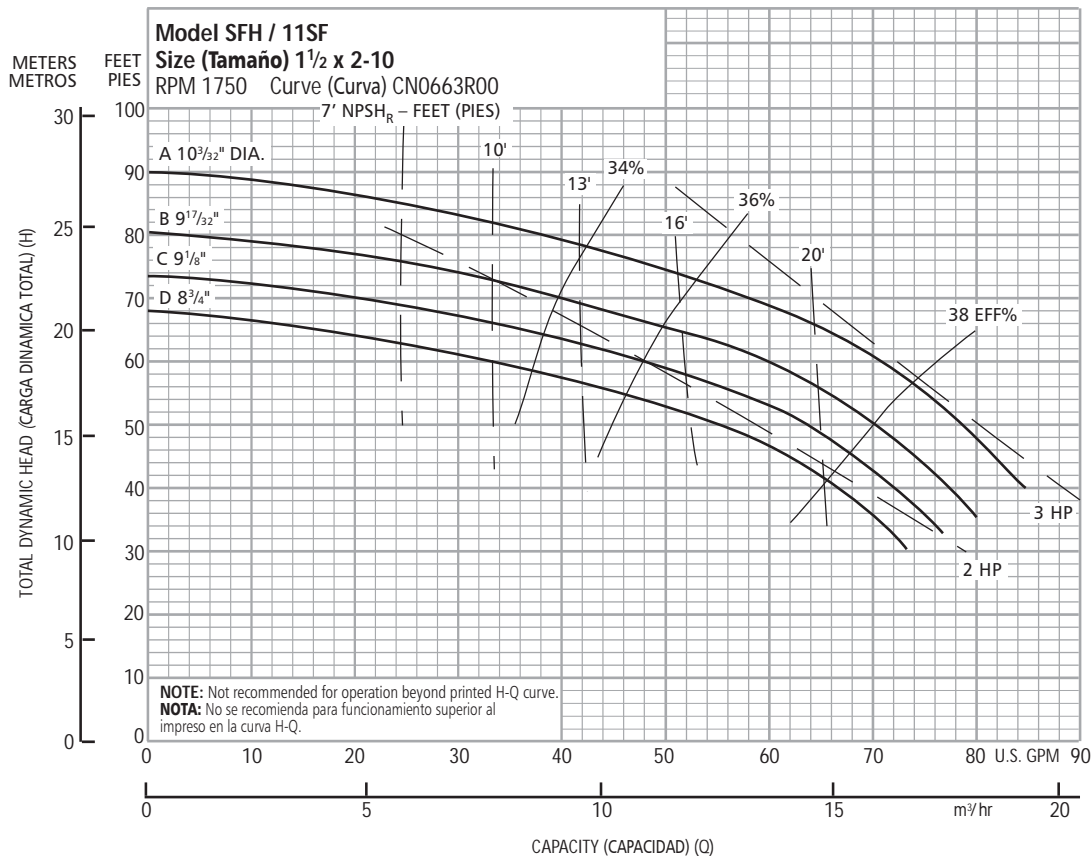

Optional Impeller, Impulsor opcional

Impeller Code, Código del impulsor	Dia., Diám.	Motor HP, HP del motor
A	10 ³ / ₃₂ "	3
B	9 ¹⁷ / ₃₂ "	2
C	9 ¹ / ₈ "	2
D	8 ³ / ₄ "	2

NOTE: Pump will pass a sphere to ³/₁₆" diameter.

NOTA: La bomba pasará una esfera a ³/₁₆" diámetro.

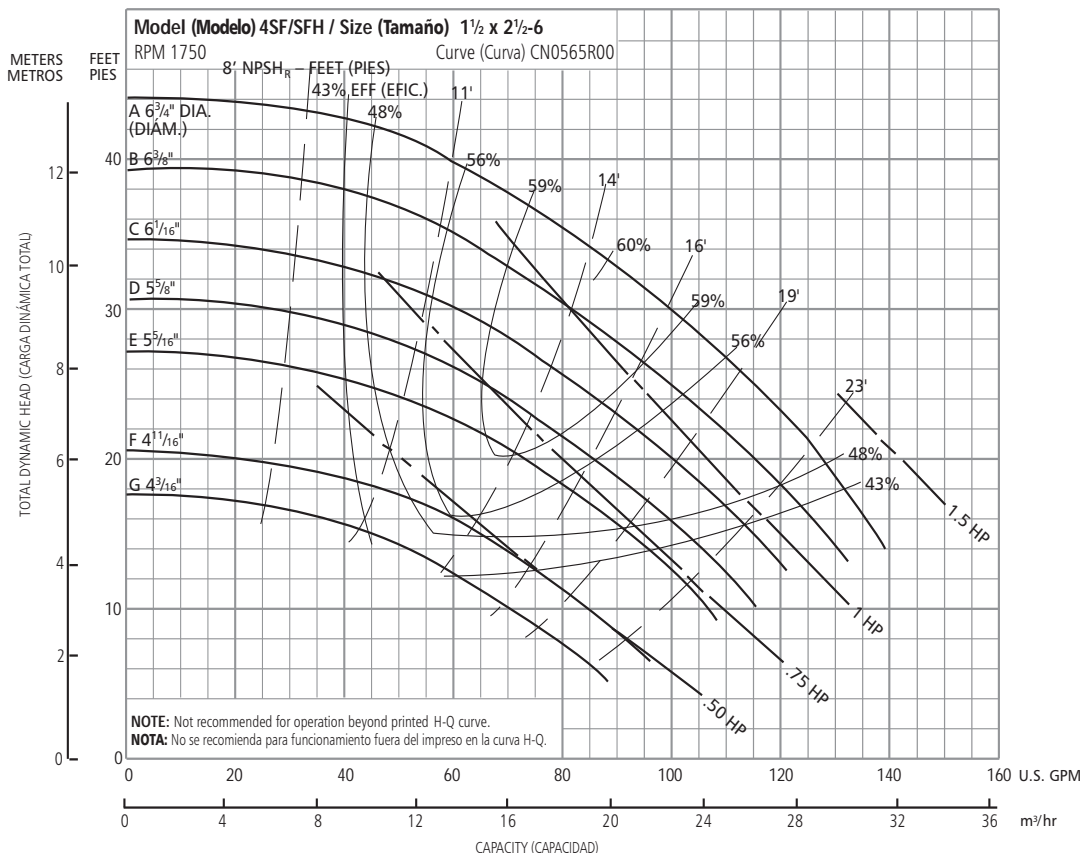

Optional Impeller, Impulsor opcional

Impeller Code, Código del impulsor	Dia., Diám.	Motor HP, HP del motor
A	6 ³ / ₄ "	1½
B	6 ³ / ₈ "	1
C	6 ¹ / ₁₆ "	1
D	5 ⁵ / ₈ "	¾
E	5 ⁵ / ₁₆ "	¾
F	4 ¹¹ / ₁₆ "	½
G	4 ³ / ₁₆ "	½

NOTE: Pump will pass a sphere to ³/₁₆" diameter.

NOTA: La bomba pasará una esfera a ³/₁₆" diámetro.

Performance Curves – S-Group, 60 Hz, 1750 RPM

Curvas de funcionamiento – Grupo S, 60 Hz, 1750 RPM

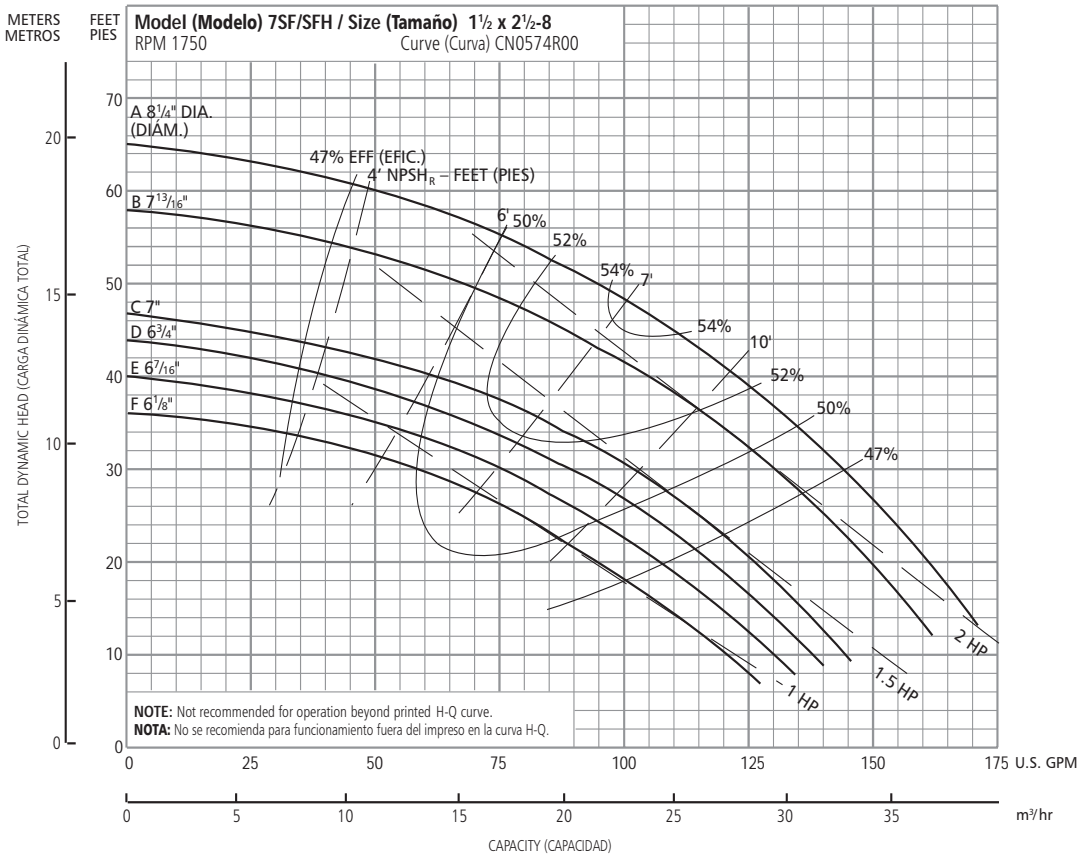

Optional Impeller, Impulsor opcional		
Impeller Code, Código del impulsor	Dia., Diám.	Motor HP, HP del motor
A	8 ¼"	2
B	7 13/16"	2
C	7	1 ½
D	6 ¾"	1 ½
E	6 7/16"	1
F	6 1/8"	1

NOTE: Pump will pass a sphere to 3/16" diameter.

NOTA: La bomba pasará una esfera a 3/16" diámetro.

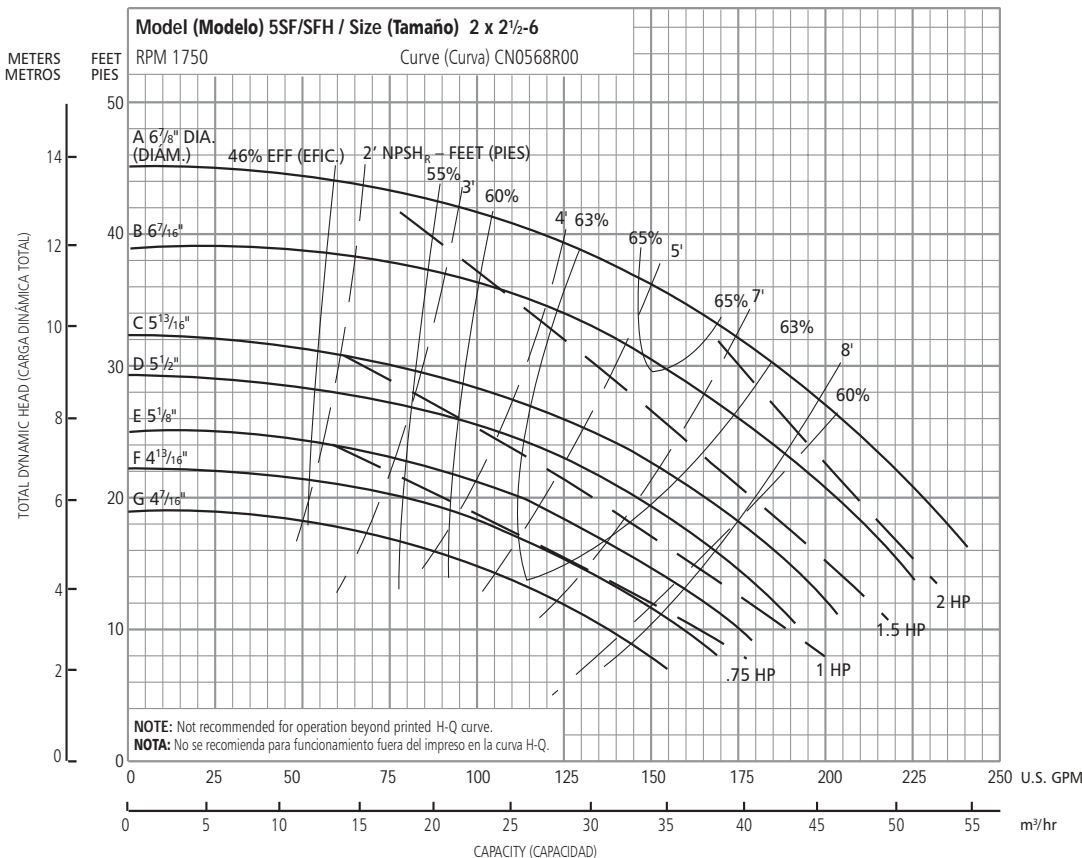

Optional Impeller, Impulsor opcional		
Impeller Code, Código del impulsor	Dia., Diám.	Motor HP, HP del motor
A	6 7/8"	2
B	6 7/16"	2
C	5 13/16"	1 ½
D	5 ½"	1
E	5 1/8"	1
F	4 13/16"	¾
G	4 7/16"	¾

NOTE: Pump will pass a sphere to 5/32" diameter.

NOTA: La bomba pasará una esfera a 5/32" diámetro.

Performance Curves – S-Group, 60 Hz, 1750 RPM
Curvas de funcionamiento – Grupo S, 60 Hz, 1750 RPM

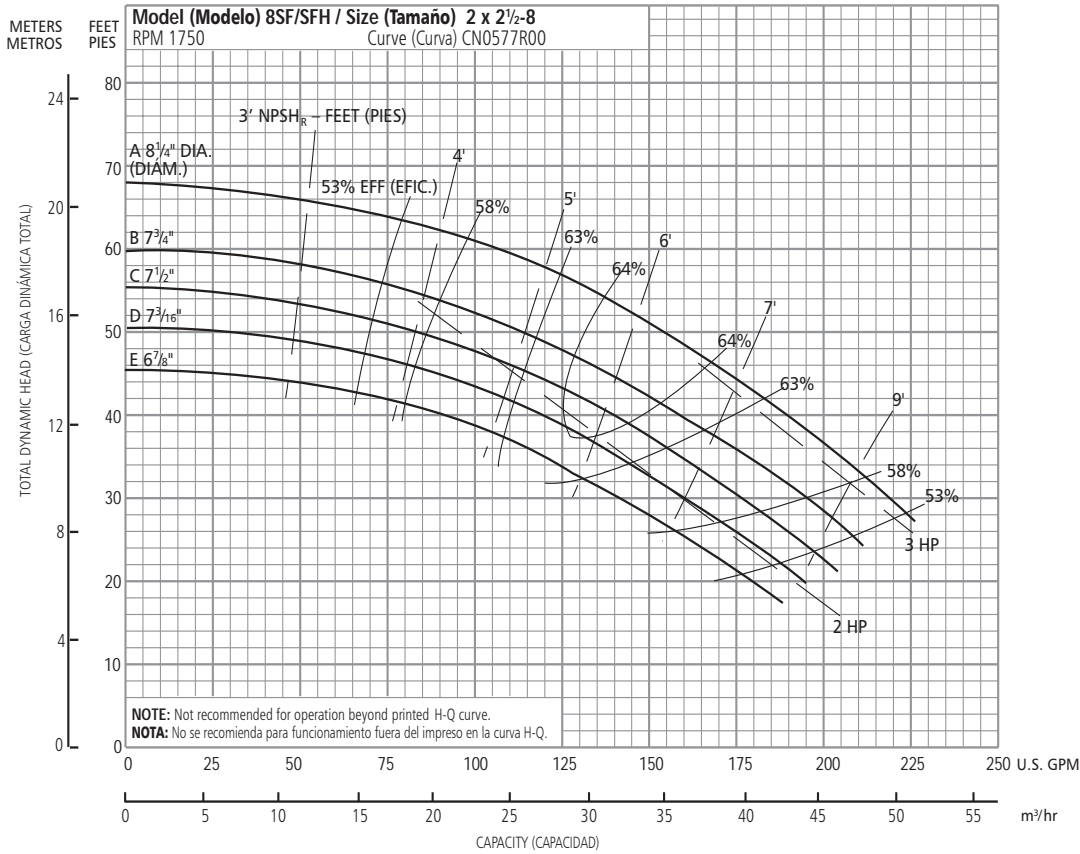

Optional Impeller, Impulsor opcional		
Impeller Code, Código del impulsor	Dia., Diám.	Motor HP, HP del motor
A	8¼"	3
B	7¾"	3
C	7½"	2
D	7⅞"	2
E	6⅞"	2

NOTE: Pump will pass a sphere to ⅝" diameter.

NOTA: La bomba pasará una esfera a ⅝" diámetro.

Performance Curves – M-Group, 60 Hz, 1750 RPM
Curvas de funcionamiento – Grupo M, 60 Hz, 1750 RPM

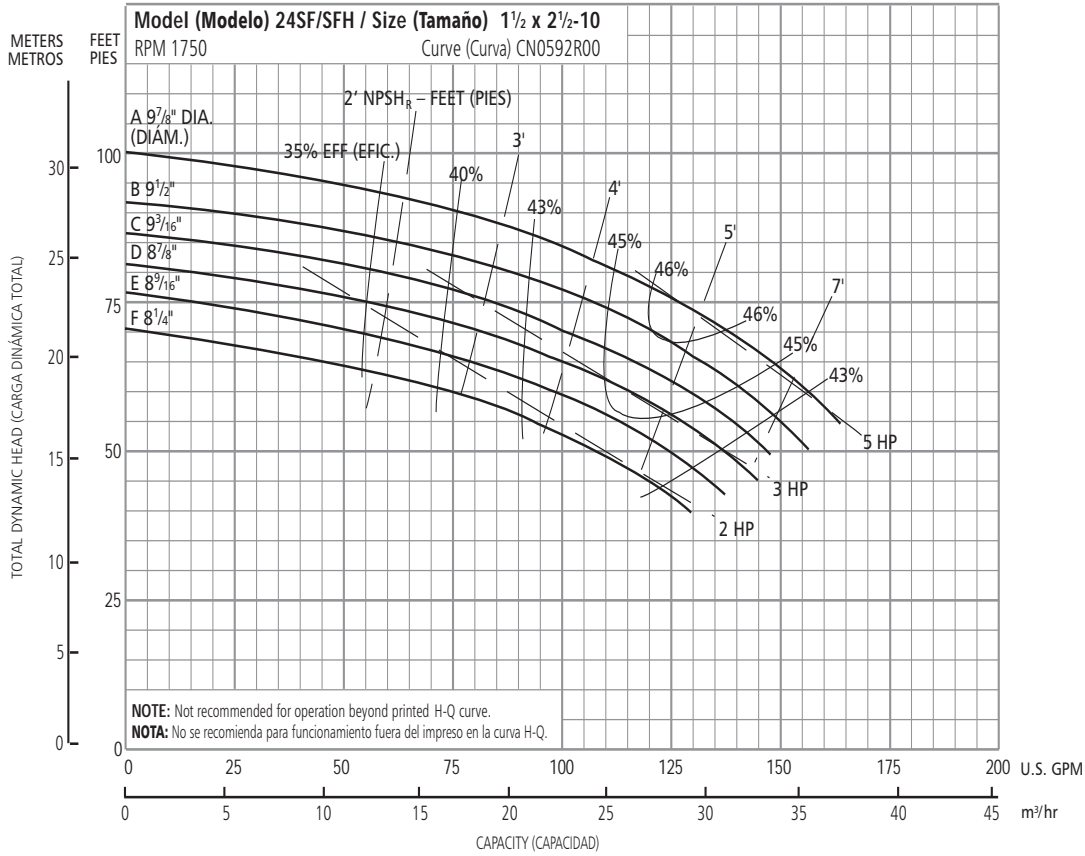

Optional Impeller, Impulsor opcional		
Impeller Code, Código del impulsor	Dia., Diám.	Motor HP, HP del motor
A	9 7/8"	5
B	9 1/2"	5
C	9 3/16"	3
D	8 7/8"	3
E	8 9/16"	2
F	8 1/4"	2

NOTE: Pump will pass a sphere to 5/16" diameter.

NOTA: La bomba pasará una esfera a 5/16" diámetro.

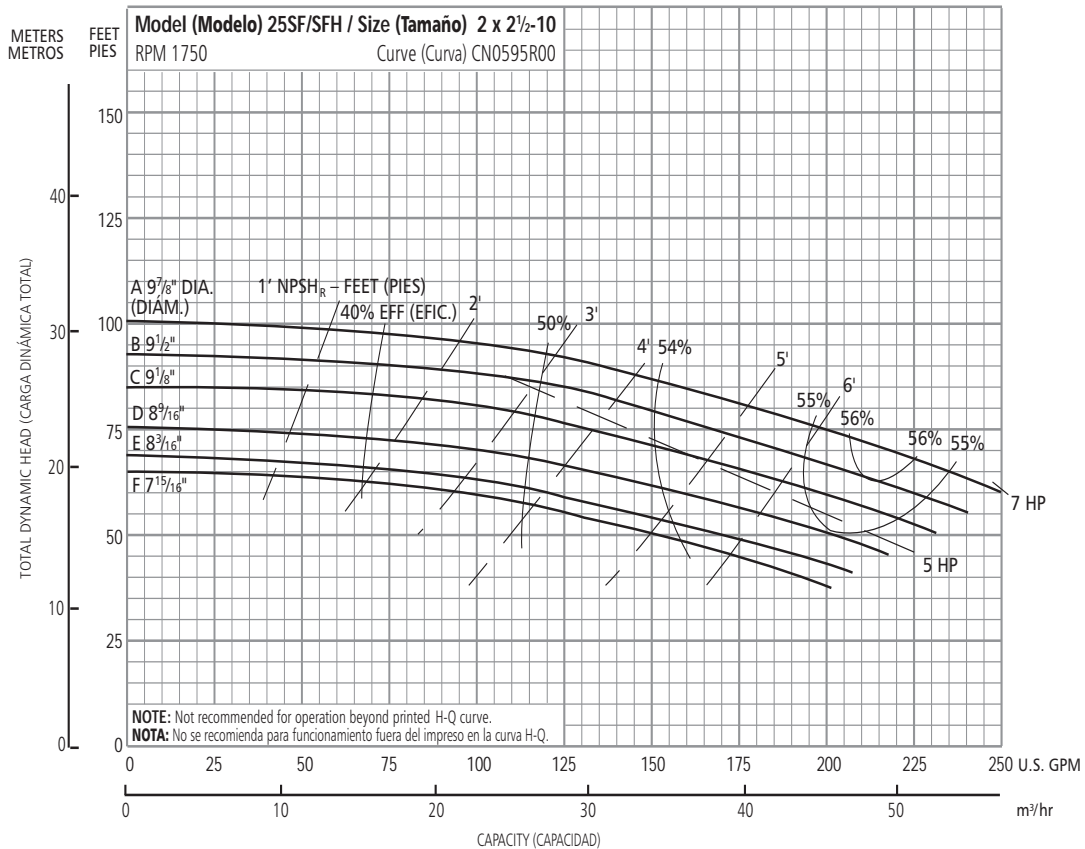

Optional Impeller, Impulsor opcional		
Impeller Code, Código del impulsor	Dia., Diám.	Motor HP, HP del motor
A	9 7/8"	7 1/2
B	9 1/2"	7 1/2
C	9 1/8"	5
D	8 9/16"	5
E	8 3/16"	5
F	7 15/16"	5

NOTE: Pump will pass a sphere to 1/2" diameter.

NOTA: La bomba pasará una esfera a 1/2" diámetro.

Performance Curves – M-Group, 60 Hz, 1750 RPM
Curvas de funcionamiento – Grupo M, 60 Hz, 1750 RPM

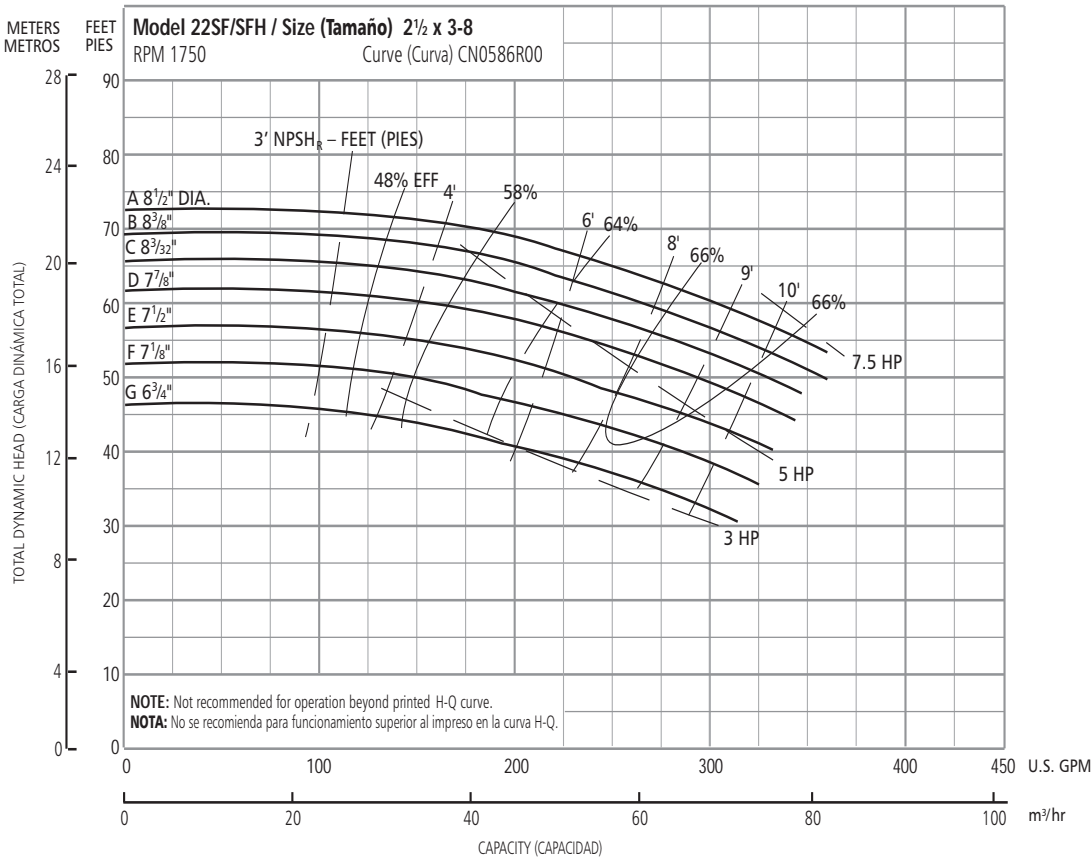

Optional Impeller, Impulsor opcional		
Impeller Code, Código del impulsor	Dia., Diám.	Motor HP, HP del motor
A	8 1/2"	7 1/2
B	8 3/8	7 1/2
C	8 3/32	7 1/2
D	7 7/8	5
E	7 1/2	5
F	7 1/8	5
G	6 3/4	3

NOTE: Pump will pass a sphere to 5/32" diameter.

NOTA: La bomba pasará una esfera a 5/32" diámetro.

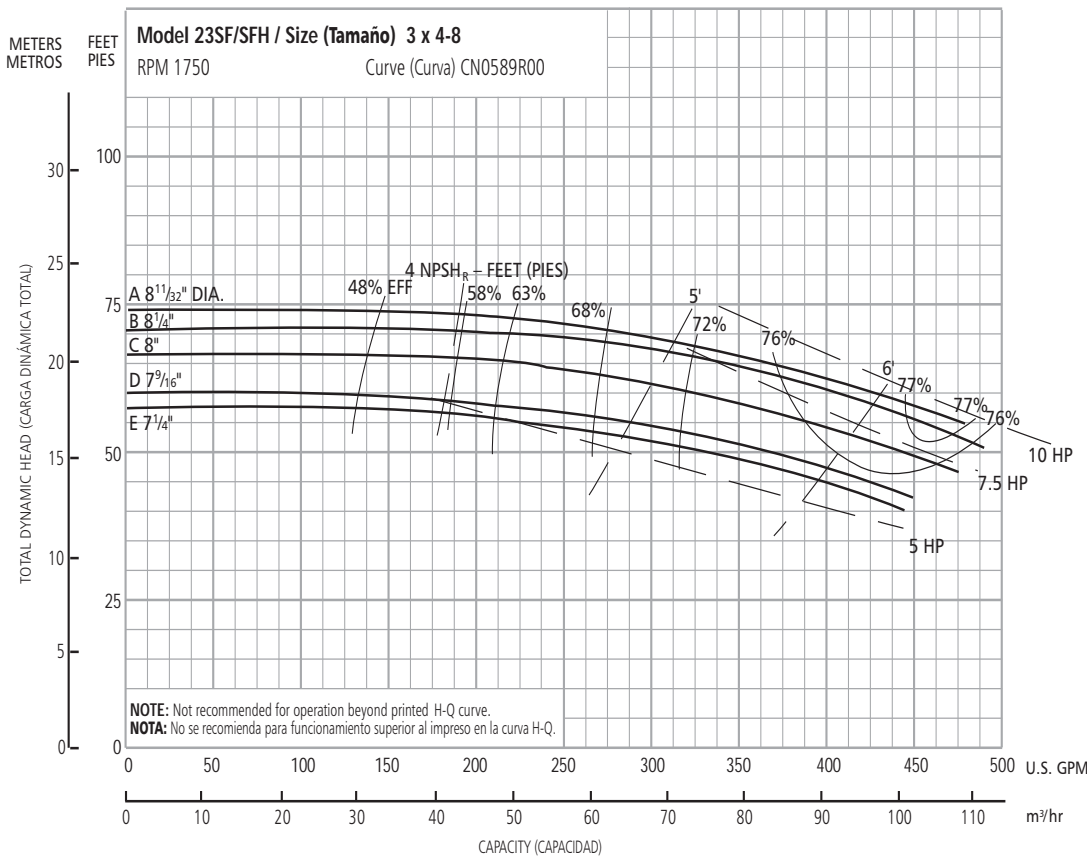

Optional Impeller, Impulsor opcional		
Impeller Code, Código del impulsor	Dia., Diám.	Motor HP, HP del motor
A	8 11/32"	10
B	8 1/4	10
C	8	7 1/2
D	7 9/16	5
E	7 1/4	5

NOTE: Pump will pass a sphere to 5/32" diameter.

NOTA: La bomba pasará una esfera a 5/32" diámetro.

Performance Curves – M-Group, 60 Hz, 1750 RPM
Curvas de funcionamiento – Grupo M, 60 Hz, 1750 RPM

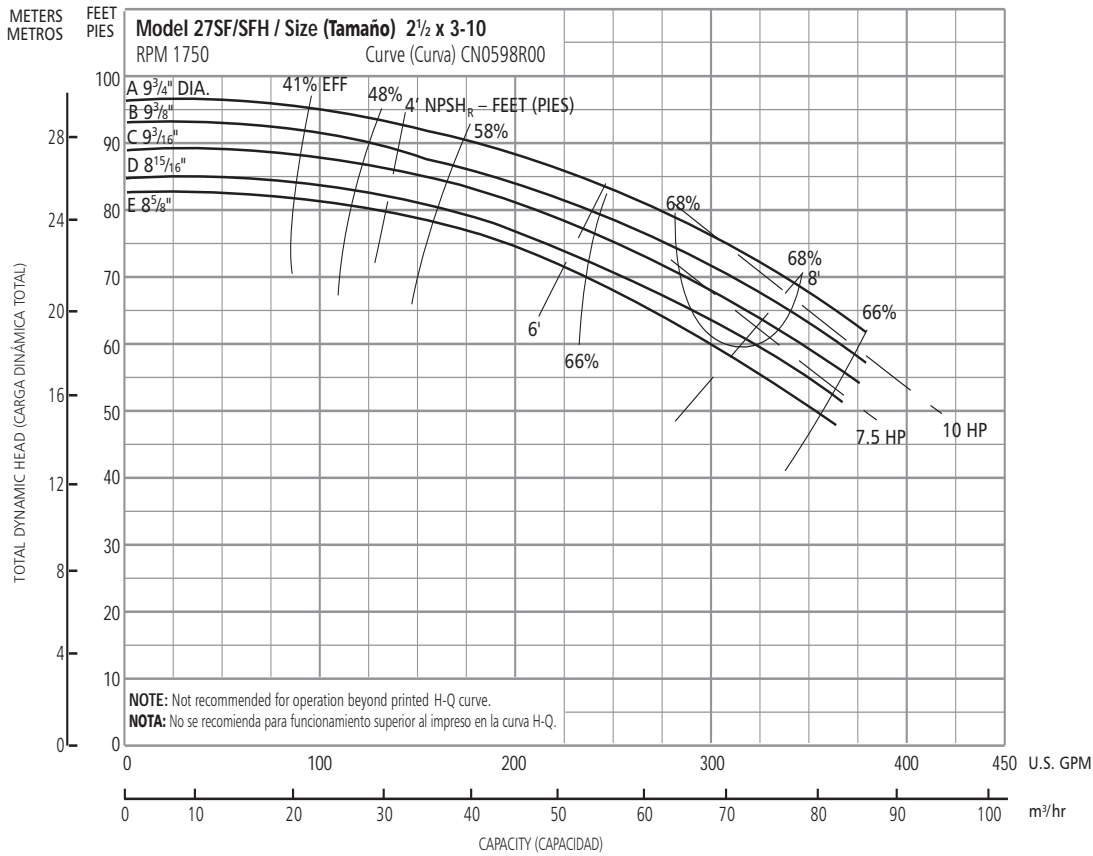

Optional Impeller, Impulsor opcional		
Impeller Code, Código del impulsor	Dia., Diám.	Motor HP, HP del motor
A	9 3/4"	10
B	9 7/8"	10
C	9 1/2"	7 1/2
D	8 15/16"	7 1/2
E	8 5/8"	7 1/2

NOTE: Pump will pass a sphere to 5/32" diameter.

NOTA: La bomba pasará una esfera a 5/32" diámetro.

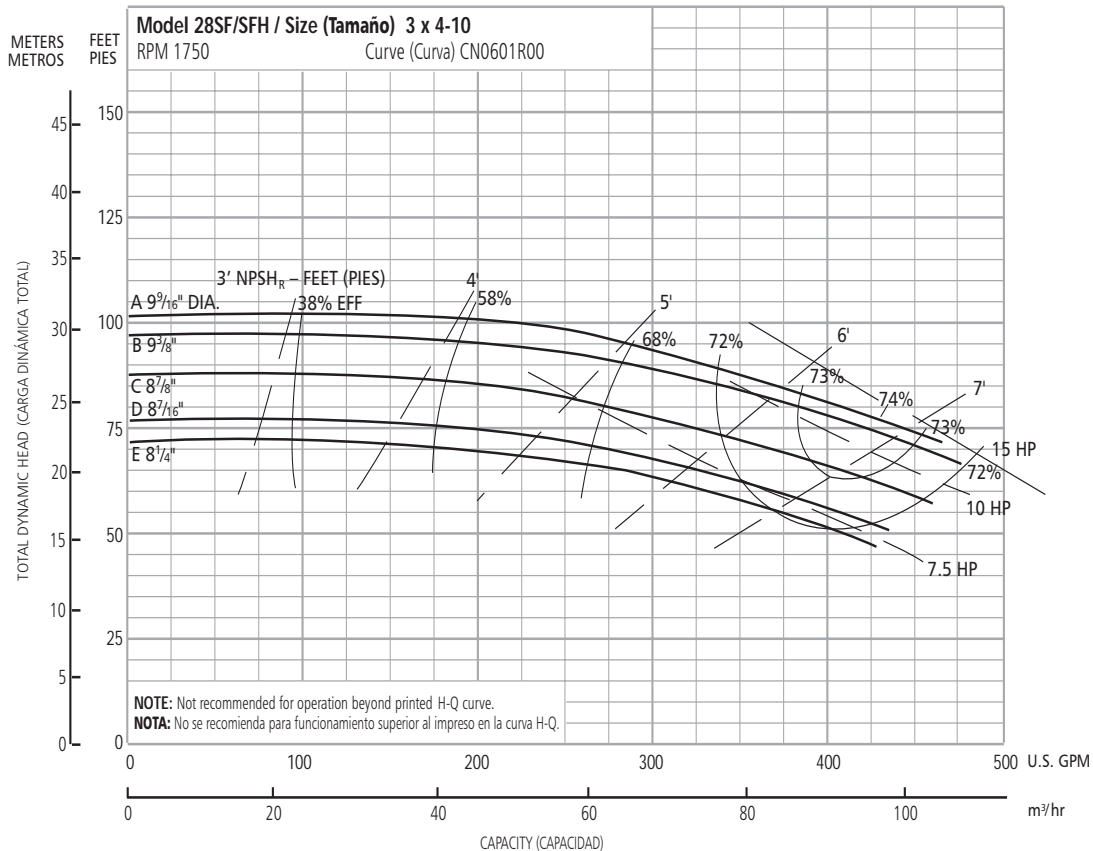

Optional Impeller, Impulsor opcional		
Impeller Code, Código del impulsor	Dia., Diám.	Motor HP, HP del motor
A	9 9/16"	15
B	9 7/8"	10
C	8 7/8"	10
D	8 7/16"	7 1/2
E	8 1/4"	7 1/2

NOTE: Pump will pass a sphere to 5/32" diameter.

NOTA: La bomba pasará una esfera a 5/32" diámetro.

Performance Curves – S-Group, 50 Hz, 2900 RPM
Curvas de funcionamiento – Grupo S, 50 Hz, 2900 RPM

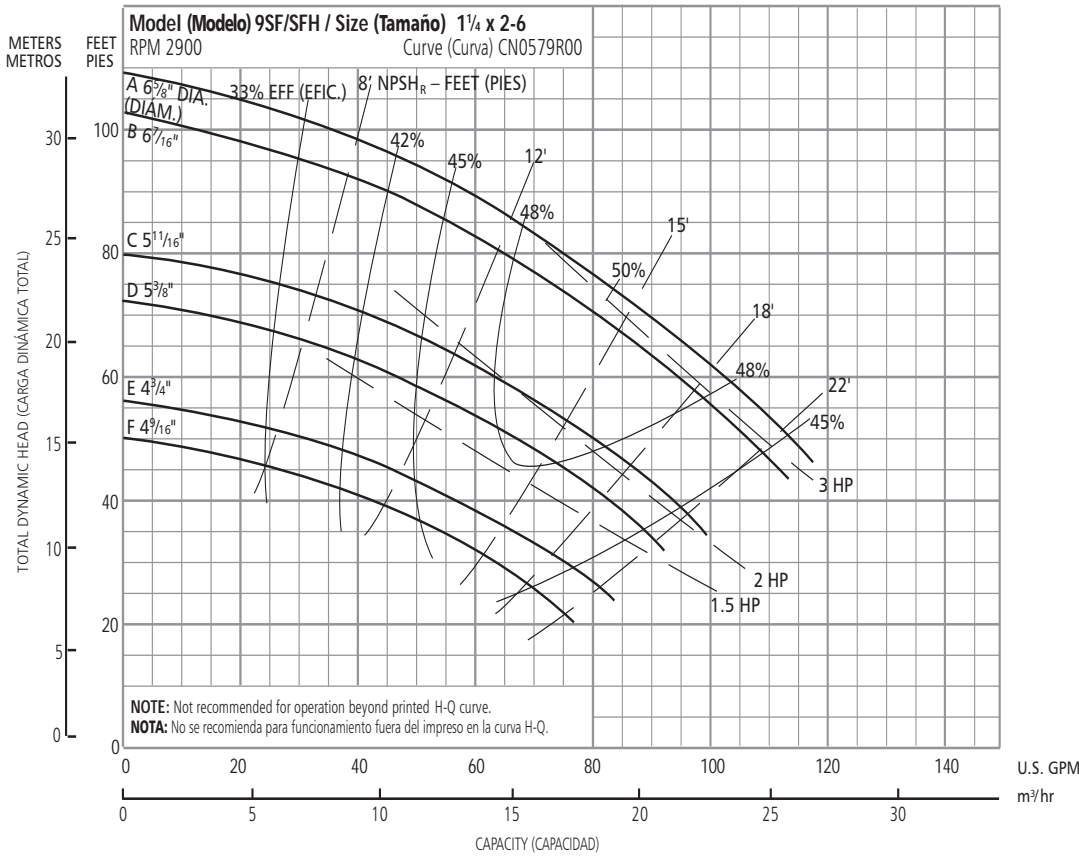

Optional Impeller, Impulsor opcional		
Impeller Code, Código del impulsor	Dia., Diám.	Motor HP, HP del motor
A	6 5/8"	3
B	6 7/16"	3
C	5 11/16"	2
D	5 3/8"	1 1/2
E	4 3/4"	1 1/2
F	4 9/16"	1

NOTE: Pump will pass a sphere to 1/8" diameter.

NOTA: La bomba pasará una esfera a 1/8" diámetro.

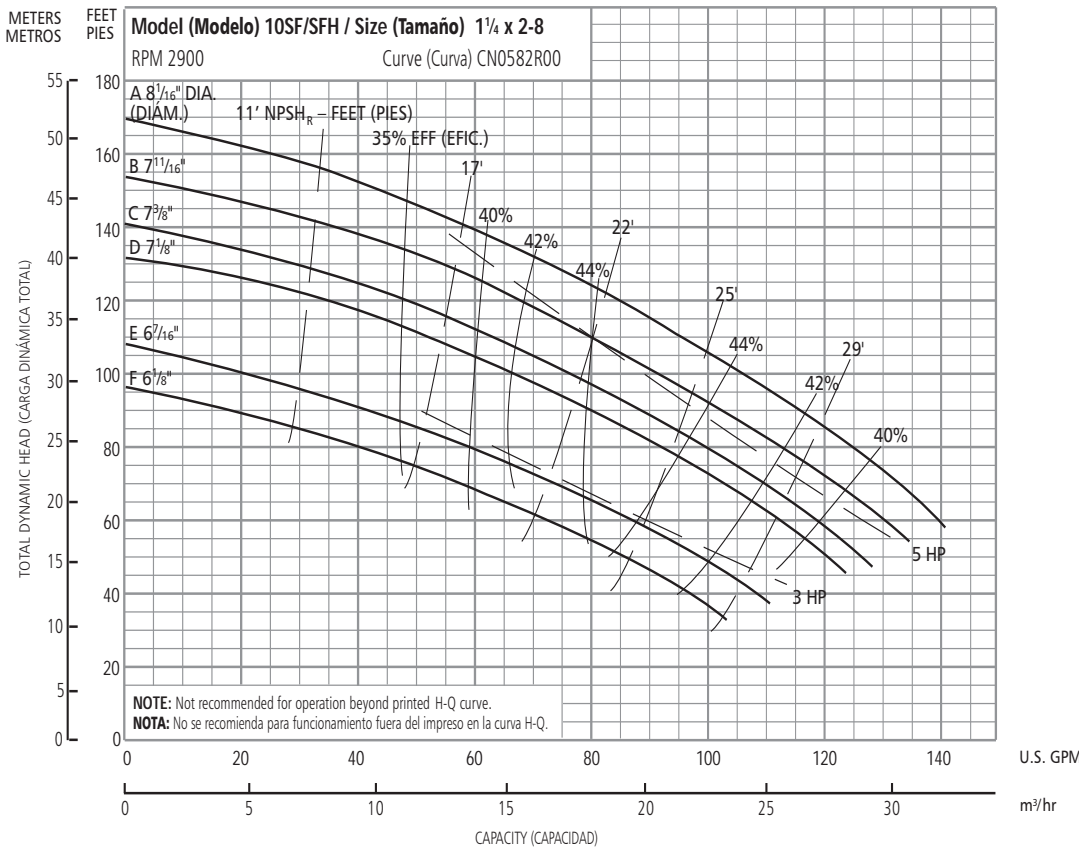

Optional Impeller, Impulsor opcional		
Impeller Code, Código del impulsor	Dia., Diám.	Motor HP, HP del motor
A	8 1/16"	5
B	7 11/16"	5
C	7 7/8"	5
D	7 1/8"	5
E	6 7/16"	3
F	6 1/8"	3

NOTE: Pump will pass a sphere to 1/8" diameter.

NOTA: La bomba pasará una esfera a 1/8" diámetro.

Performance Curves – S-Group, 50 Hz, 2900 RPM
Curvas de funcionamiento – Grupo S, 50 Hz, 2900 RPM

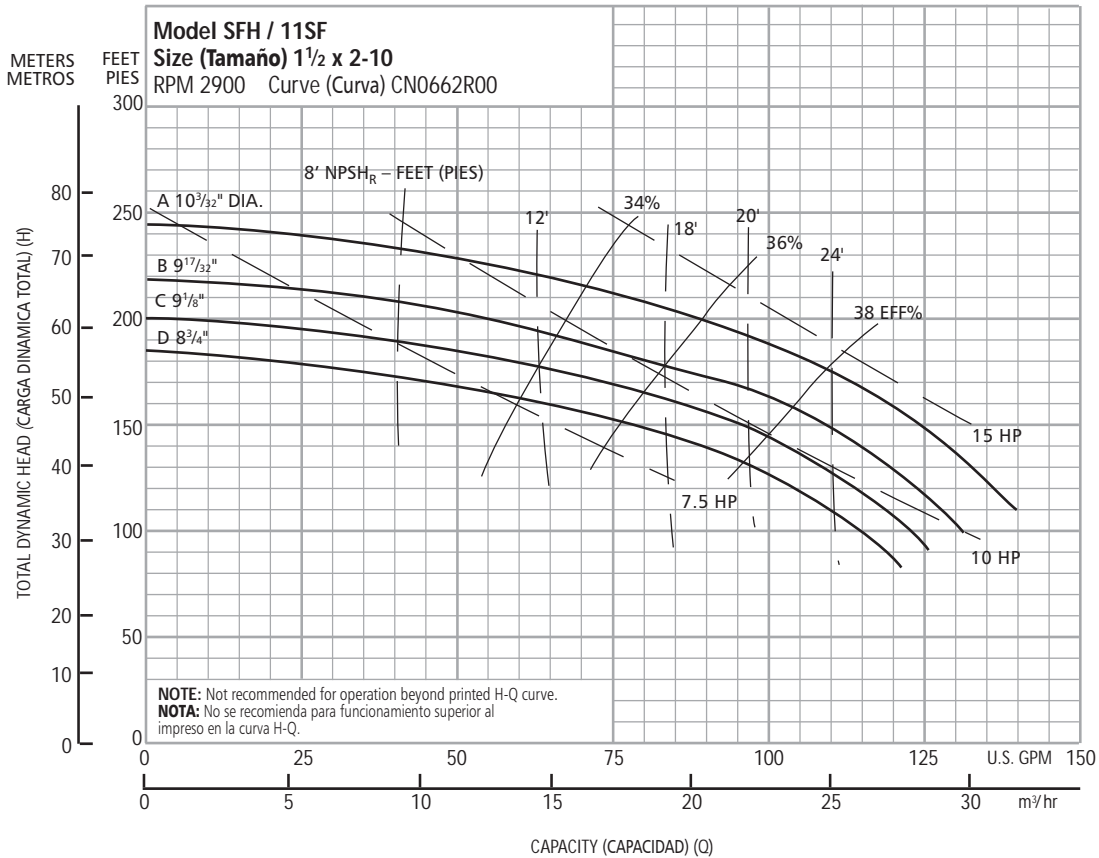

Optional Impeller, Impulsor opcional		
Impeller Code, Código del impulsor	Dia., Diám.	Motor HP, HP del motor
A	10 ³ / ₃₂ "	15
B	9 ¹⁷ / ₃₂ "	10
C	9 ¹ / ₈ "	10
D	8 ³ / ₄ "	7 1/2

NOTE: Pump will pass a sphere to 3/16" diameter.
NOTA: La bomba pasará una esfera a 3/16" diámetro.

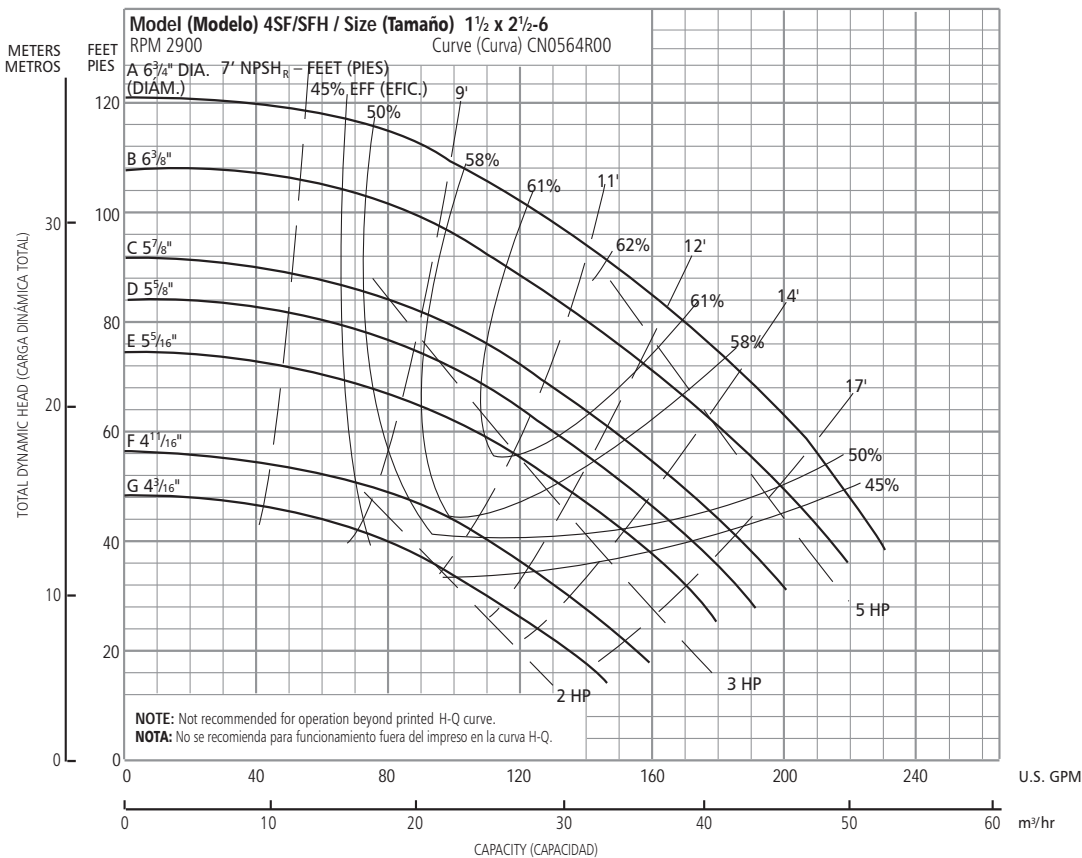

Optional Impeller, Impulsor opcional		
Impeller Code, Código del impulsor	Dia., Diám.	Motor HP, HP del motor
A	6 ³ / ₄ "	5
B	6 ³ / ₈ "	5
C	5 ⁷ / ₈ "	5
D	5 ⁵ / ₈ "	5
E	5 ⁵ / ₁₆ "	3
F	4 ¹¹ / ₁₆ "	3
G	4 ³ / ₁₆ "	2

NOTE: Pump will pass a sphere to 3/16" diameter.
NOTA: La bomba pasará una esfera a 3/16" diámetro.

Performance Curves – S-Group, 50 Hz, 2900 RPM
Curvas de funcionamiento – Grupo S, 50 Hz, 2900 RPM

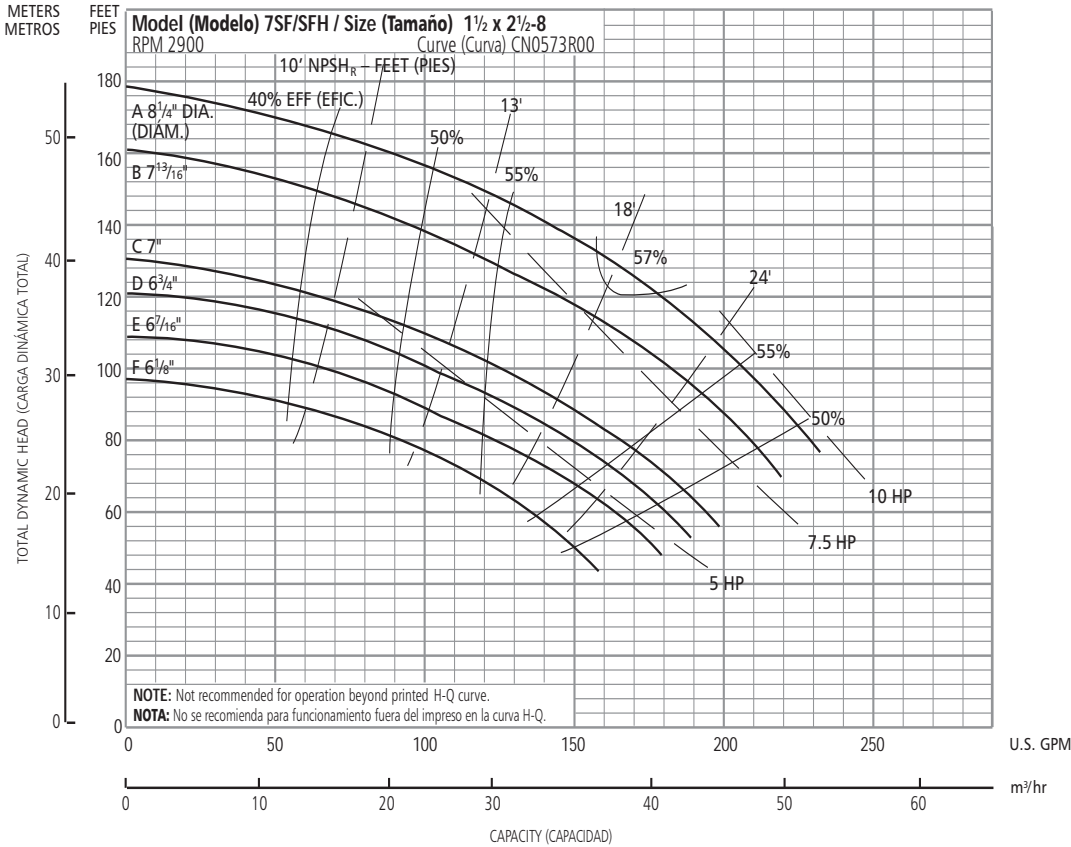

Optional Impeller, Impulsor opcional		
Impeller Code, Código del impulsor	Dia., Diám.	Motor HP, HP del motor
A	8¼"	10
B	7 ¹³ / ₁₆ "	7½
C	7	5
D	6¾"	5
E	6 ⁷ / ₁₆ "	5
F	6 ¹ / ₈ "	5

NOTE: Pump will pass a sphere to ³/₁₆" diameter.

NOTA: La bomba pasará una esfera a ³/₁₆" diámetro.

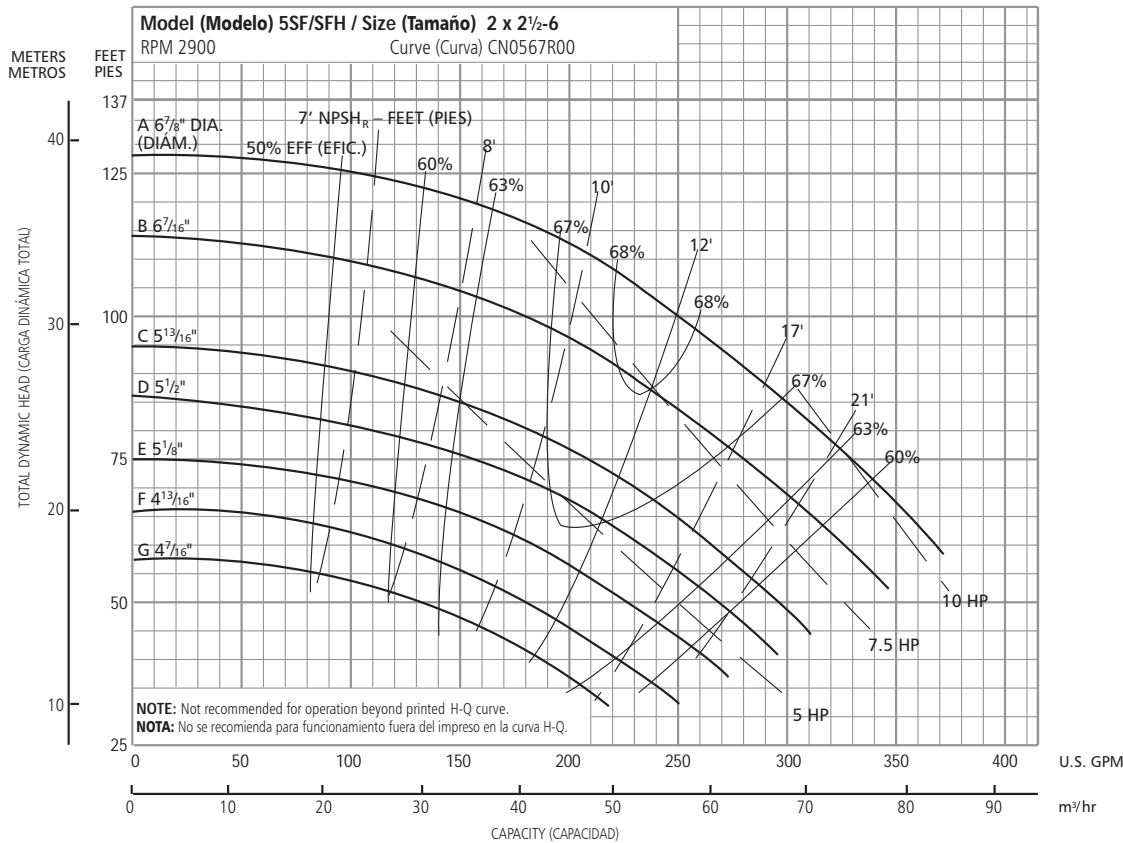

Optional Impeller, Impulsor opcional		
Impeller Code, Código del impulsor	Dia., Diám.	Motor HP, HP del motor
A	6 ⁷ / ₈ "	10
B	6 ⁷ / ₁₆ "	7½
C	5 ¹³ / ₁₆ "	7½
D	5½"	5
E	5 ¹ / ₈ "	5
F	4 ¹³ / ₁₆ "	5
G	4 ⁷ / ₁₆ "	5

NOTE: Pump will pass a sphere to ⁵/₃₂" diameter.

NOTA: La bomba pasará una esfera a ⁵/₃₂" diámetro.

Performance Curves – S-Group, 50 Hz, 2900 RPM
Curvas de funcionamiento – Grupo S, 50 Hz, 2900 RPM

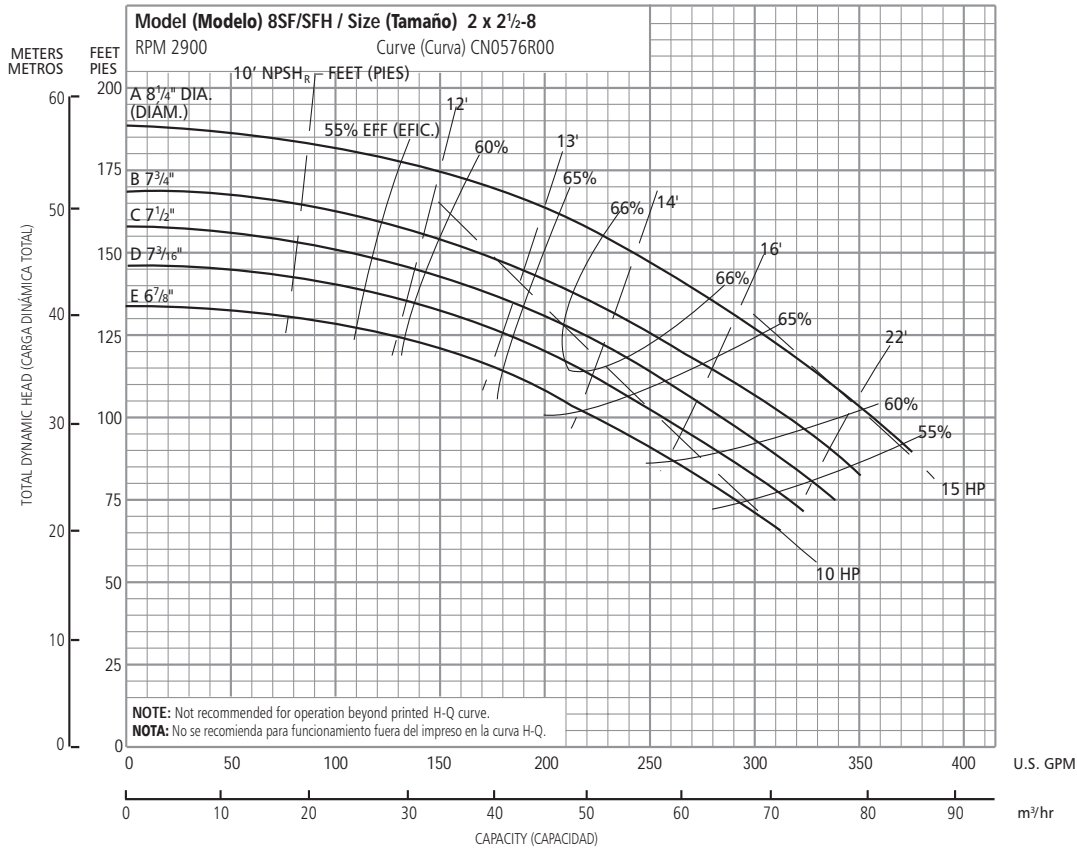

Optional Impeller, Impulsor opcional		
Impeller Code, Código del impulsor	Dia., Diám.	Motor HP, HP del motor
A	8 1/4"	15
B	7 3/4"	15
C	7 1/2"	15
D	7 3/16"	10
E	6 7/8"	10

NOTE: Pump will pass a sphere to 5/32" diameter.

NOTA: La bomba pasará una esfera a 5/32" diámetro.

Performance Curves – M-Group, 50 Hz, 2900 RPM
Curvas de funcionamiento – Grupo M, 50 Hz, 2900 RPM

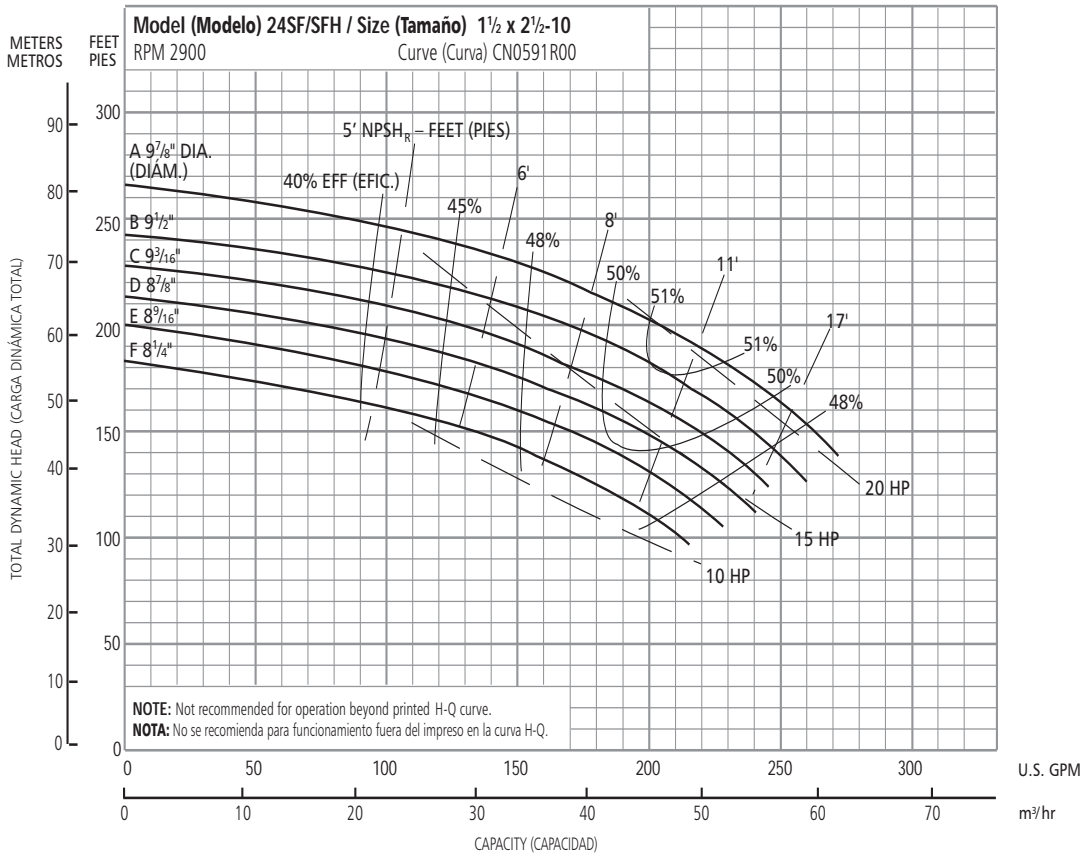

Optional Impeller, Impulsor opcional		
Impeller Code, Código del impulsor	Dia., Diám.	Motor HP, HP del motor
A	9 7/8"	20
B	9 1/2"	20
C	9 3/16"	15
D	8 7/8"	15
E	8 9/16"	15
F	8 1/4"	10

NOTE: Pump will pass a sphere to 5/16" diameter.

NOTA: La bomba pasará una esfera a 5/16" diámetro.

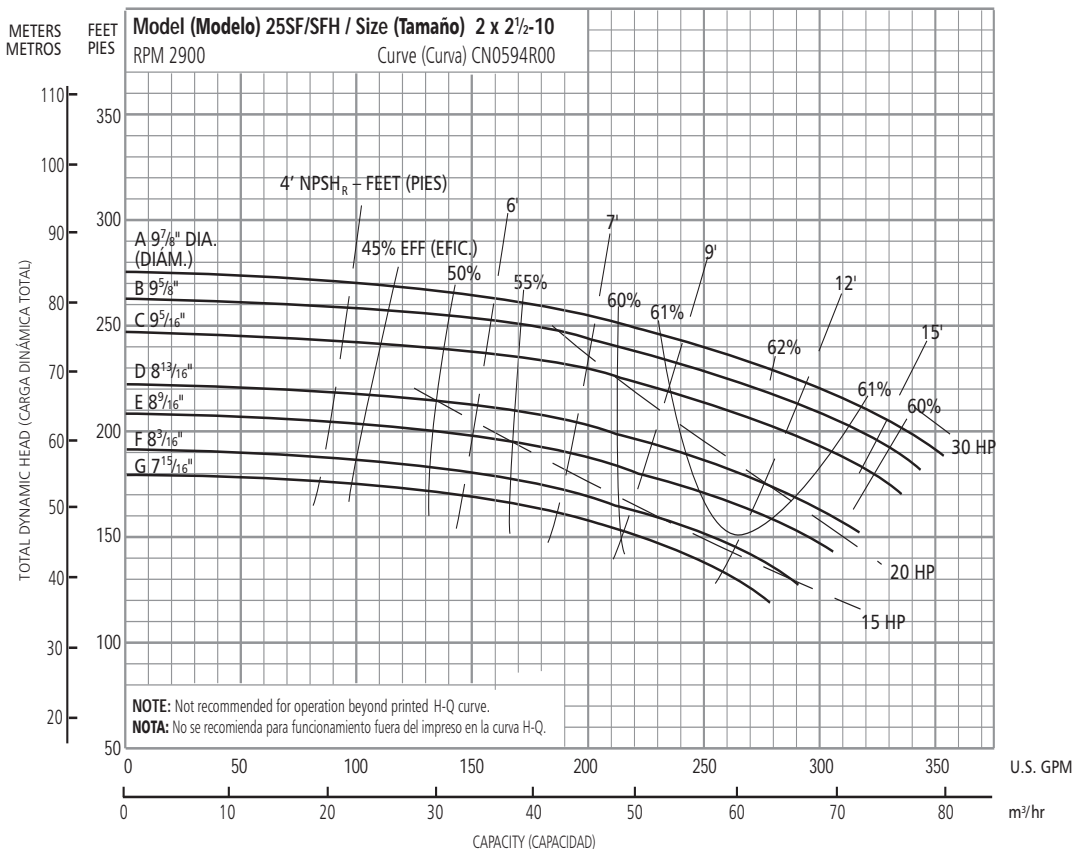

Optional Impeller, Impulsor opcional		
Impeller Code, Código del impulsor	Dia., Diám.	Motor HP, HP del motor
A	9 7/8"	30
B	9 5/8"	30
C	9 5/16"	30
D	8 13/16"	20
E	8 9/16"	20
F	8 3/16"	15
G	7 15/16"	15

NOTE: Pump will pass a sphere to 1/2" diameter.

NOTA: La bomba pasará una esfera a 1/2" diámetro.

Performance Curves – M-Group, 50 Hz, 2900 RPM
Curvas de funcionamiento – Grupo M, 50 Hz, 2900 RPM

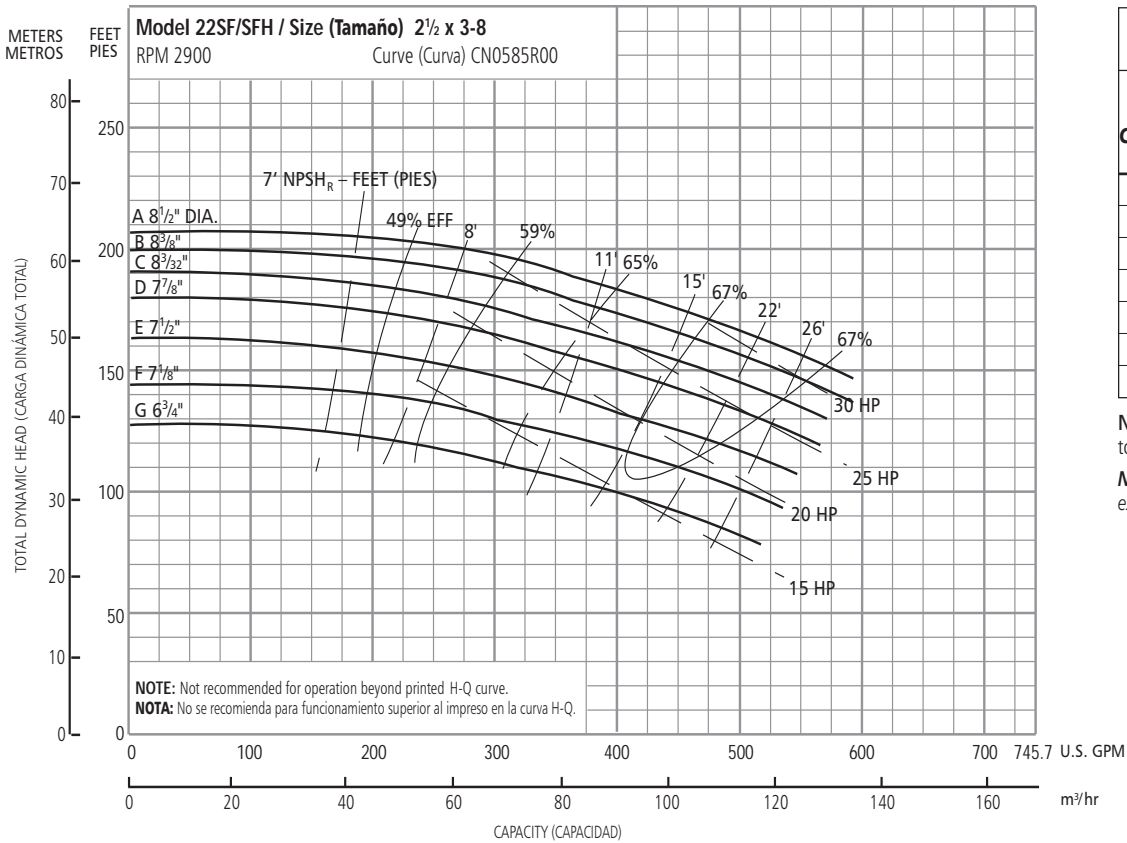

Optional Impeller, Impulsor opcional		
Impeller Code, Código del impulsor	Dia., Diám.	Motor HP, HP del motor
A	8½"	30
B	8⅝"	30
C	8¾"	25
D	7⅞"	25
E	7½"	20
F	7⅜"	20
G	6¾"	15

NOTE: Pump will pass a sphere to ⅝" diameter.

NOTA: La bomba pasará una esfera a ⅝" diámetro.

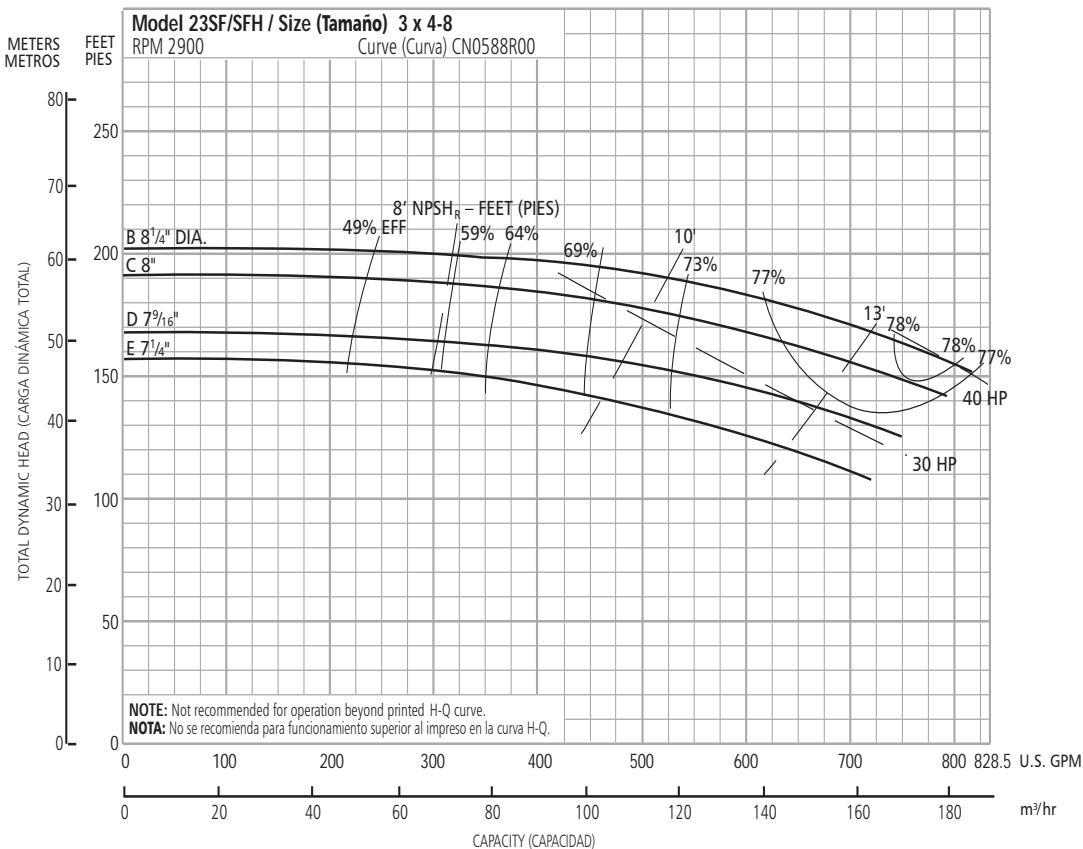

Optional Impeller, Impulsor opcional		
Impeller Code, Código del impulsor	Dia., Diám.	Motor HP, HP del motor
B	8¼"	40
C	8"	30
D	7⅞"	30
E	7¼"	25

NOTE: Pump will pass a sphere to ⅝" diameter.

NOTA: La bomba pasará una esfera a ⅝" diámetro.

Performance Curves – M-Group, 50 Hz, 2900 RPM
Curvas de funcionamiento – Grupo M, 50 Hz, 2900 RPM

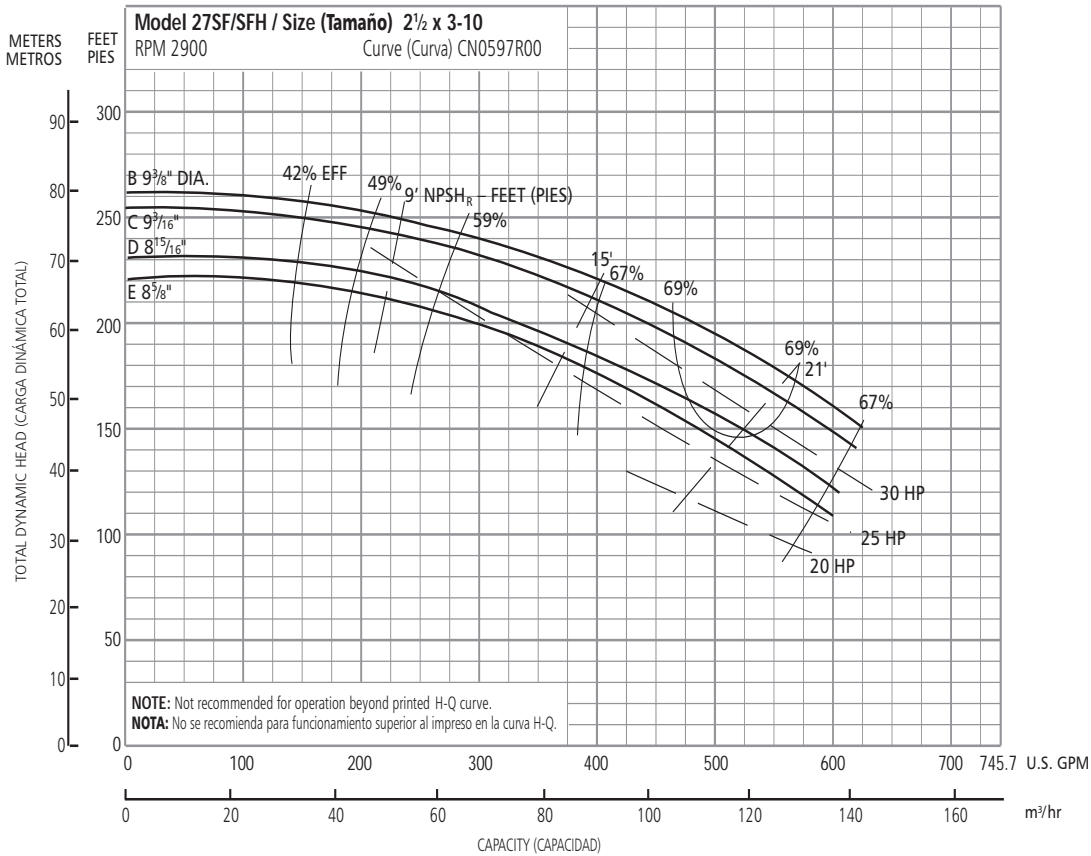

Optional Impeller, Impulsor opcional		
Impeller Code, Código del impulsor	Dia., Diám.	Motor HP, HP del motor
B	9 3/8"	30
C	9 7/16"	30
D	8 7/16"	25
E	8 3/8"	25

NOTE: Pump will pass a sphere to 5/32" diameter.

NOTA: La bomba pasará una esfera a 5/32" diámetro.

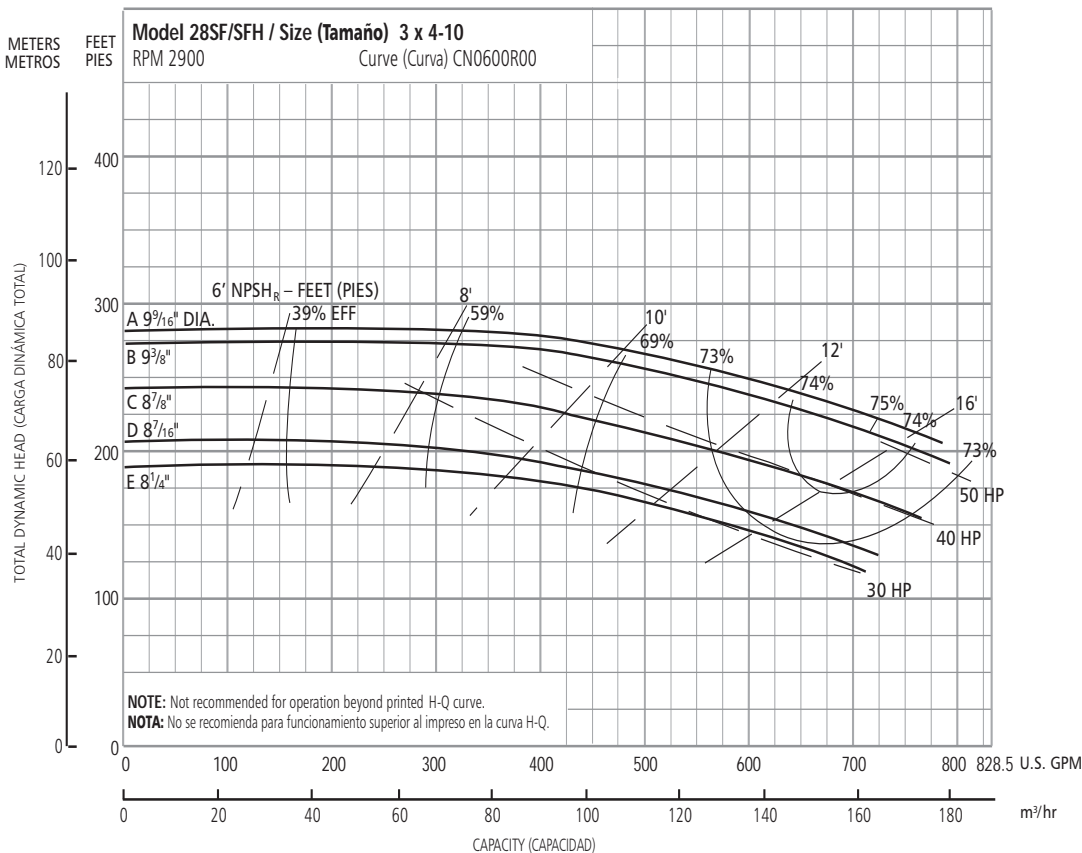

Optional Impeller, Impulsor opcional		
Impeller Code, Código del impulsor	Dia., Diám.	Motor HP, HP del motor
A	9 9/16"	50
B	9 3/8"	50
C	8 7/8"	40
D	8 7/16"	30
E	8 1/4"	30

NOTE: Pump will pass a sphere to 5/32" diameter.

NOTA: La bomba pasará una esfera a 5/32" diámetro.

SFH S-Group Close Coupled – Dimensions and Weights, SFH Acoplamiento compacto Grupo S - Dimensiones y pesos

(All dimensions in inches and weights in lbs. Do not use for construction purposes.)
(Todas las dimensiones en pulgadas y los pesos en libras. No usar para propósitos de construcción.)

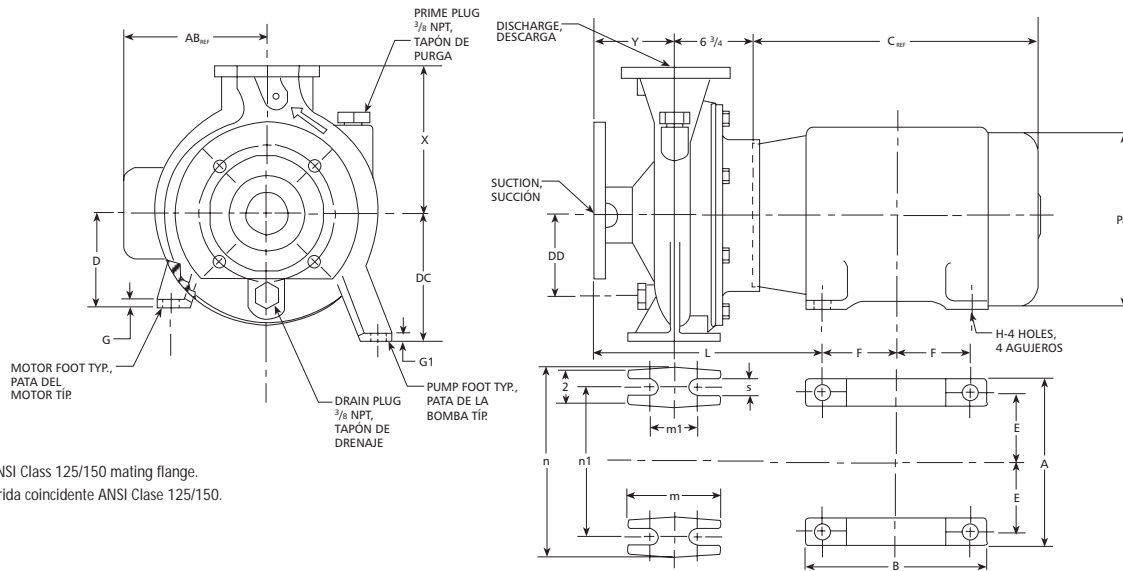

For use with ANSI Class 125/150 mating flange.
Para uso con brida coincidente ANSI Clase 125/150.

Dimensions Determined by Pump, <i>Dimensiones determinadas por la bomba</i>													Dimensions "L" Determined by Pump and Motor, <i>Dimensiones "L" determinadas por la bomba y el motor</i>					
Pump, Bomba	125/150 Flange, Brida de 125/150		DC	DD	X	Y	N	N1	M	M1	S	G	Motor Frame Size, Tamaño del armazón del motor				Wt. (lbs.), Pesos (libras)	
	Suct. Succ. ①	Disch. Desc. ①											140	180	210TCZ	250TCZ		
9SF	1 1/4 x 2 - 6	2	1 1/4	5 5/16	4	6 5/16	3 3/8	9 7/16	7 1/2	3 15/16	2 3/4	9/16	1/2	12 7/8	13 1/2	14 3/8	14 7/8	41
10SF	1 1/4 x 2 - 8			6 5/16	4 3/4	7 1/16								69				
4SF	1 1/2 x 2 1/2 - 6	2 1/2	1 1/2	5 3/16	4	6 3/16	3 15/16	10 1/16	8 5/16	3 15/16	2 3/4	9/16	1/2	13 1 1/16	14 5/16	15 3/16	15 5/16	49
7SF	1 1/2 x 2 1/2 - 8			4 3/4	7 1/16	85												
5SF	2 x 2 1/2 - 6			6 5/16	4 7/16	7 1/16								88				
8SF	2 x 2 1/2 - 8			14 1/16	7 3/4	125												
11SF	1 1/2 x 2 - 10	2	1 1/2	7 3/32	5 3/4	8 3/4	3 13/16	12 14/32	9 27/32	4 29/32	3 3/4	9/16	15 5/8	16 1/4	17 1/2	17 3/8	105	

① For use with ANSI class 125/150 mating flanges.
Para usar con bridas coincidentes ANSI clase 125/150.

NOTE:
1. ALL dimensions in inches.
2. Motor dimensions may vary with motor manufacturer.
3. Not for construction purposes.

NOTA:
1. TODAS las dimensiones en pulgadas.
2. Las dimensiones puede que varíen con los fabricantes.
3. No usar para propósitos de construcción.

Dimensions Determined by JP Motor Frame, Dimensiones determinadas por el armazón del motor JP

JP Frame, Armazón JP	A	AB Ref.	B	C Ref.	D	E	F	G	H Dia., H Diám.	P Ref.
143JP	6 1/2	5 1/4	6	11 1/4	3 1/2	2 3/4	2	1/8	1 1/32	6 5/8
145JP							2 1/2			
182JP	8 1/2	5 7/8	6 1/2	13 1/2	4 1/2	3 3/4	2 1/4	3/16	1 1/32	7 7/8
184JP							2 3/4			
213TCZ	9 1/2	7 3/8	8	15 1/2	5 1/4	4 1/4	3 1/2	7/32	1 1/32	9 5/8
215TCZ							3 3/2			
254TCZ	11 1/4	9	9 1/2	20 1/2	6 1/4	5	4 1/8	1/4	1 7/32	12 15/16
256TCZ			11 3/4				5			

Motor Frame Selections, Selecciones del armazón del motor

Motor Frame, Armazón del motor	Motor Horsepower, <i>Potencia del motor</i>								Motor Wt. (lbs.) Peso motor (lib.)
	3500 RPM, <i>3500 RPM</i>				1750 RPM, <i>1750 RPM</i>				
	1Ø, <i>Monofásicos</i>		3Ø, <i>Trifásicos</i>		1Ø, <i>Monofásicos</i>		3Ø, <i>Trifásicos</i>		
	ODP	TEFC	ODP	TEFC	ODP	TEFC	ODP	TEFC	
143JP	1/2-1 1/2	1/2-1 1/2	1/2-1 1/2	1/2-1 1/2	1/2-1	1/2-3/4	1/2-3/4	1/2-3/4	41
145JP	2	2	2-3	2	1 1/2	1-1 1/2	1 1/2-2	1 1/2-2	57
182JP	3	3	5	3	2	2-3	3	3	77
184JP	5	5	7 1/2	5	3	—	5	5	97
213TCZ	7 1/2	—	10	—	—	—	7 1/2	7 1/2	122
215TCZ	10	—	10-15	15	—	—	—	—	156
254TCZ	—	—	20	—	—	—	—	—	265
256TCZ	—	—	25	20	—	—	—	—	320

SFH M-Group Close Coupled – Dimensions and Weights, SFH Acoplamiento compacto Grupo M - Dimensiones y pesos

(All dimensions in inches and weights in lbs. Do not use for construction purposes.)
(Todas las dimensiones en pulgadas y los pesos en libras. No usar para propósitos de construcción.)

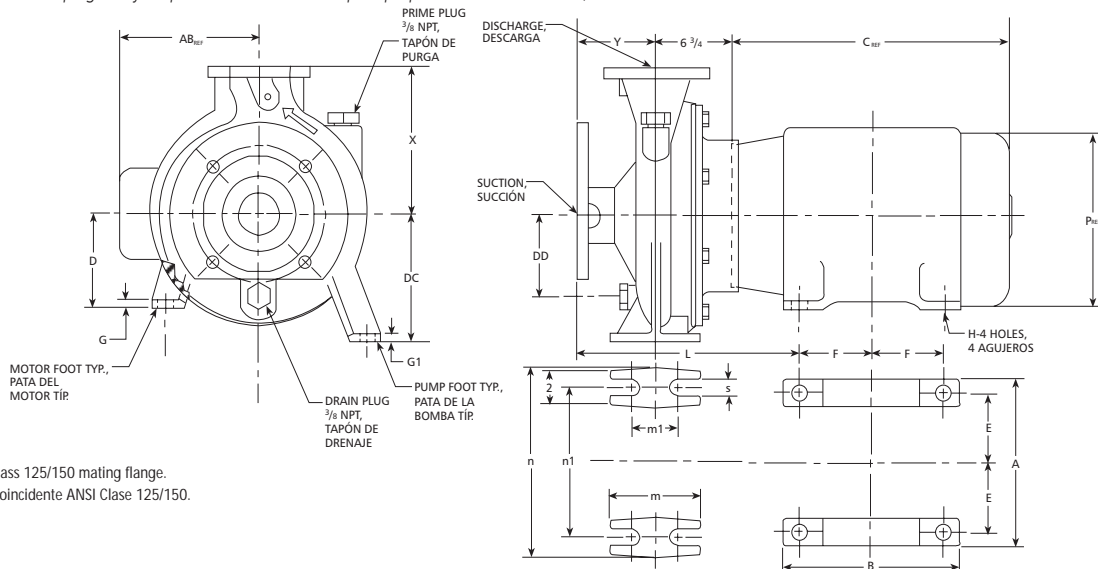

For use with ANSI Class 125/150 mating flange.
Para uso con brida coincidente ANSI Clase 125/150.

Dimensions Determined by Pump, Dimensiones determinadas por la bomba												Dimensions "L" Determined by Pump and Motor, Dimensiones "L" determinadas por la bomba y el motor									
Pump, Bomba	125/150 Flange, Brida de 125/150		DC	DD	X	Y	N	N1	M	M1	S	G1	Motor Frame Size, Tamaño del armazón del motor						Wt. (lbs.), Pesos (libras)		
	Suct. Succ. ①	Disch. Desc. ①											140	180	210TCZ	250	280	320		360	
24SF	1½ x 2 – 10	2	1½																		105
25SF	2 x 2½ – 10	2½	2	7¾	5¾	8¾	3¼	12¼	9¾	4¾	3¼	¾	¾	13¾	14¾	16¾	16¾	16¾	17¾	17¾	115
22SF	2½ x 3 – 8	3	2½		5½																127
27SF	2½ x 3 – 10			7½	6½	9¾	14¾	11¾	6¾	4¾	2¾	¾									
23SF	3 x 4 – 8	4	3		7¾	5¾	4¼	13¾	11¾	4¾	3¼	¾	¾	15¾	16¼	17¾	17¾	17¾	18¾	18¾	145
28SF	3 x 4 – 10			7¾	6½	10¾	15¾	12¾	6¾	4¾	2¾	¾									

① For use with ANSI class 125/150 mating flanges.
Para usar con bridas coincidentes ANSI clase 125/150.

NOTES:
1. ALL dimensions in inches.
2. Motor dimensions may vary with motor manufacturer.
3. Not for construction purposes.

NOTAS:
1. TODAS las dimensiones en pulgadas.
2. Las dimensiones puede que varíen con los fabricantes.
3. No usar para propósitos de construcción.

Dimensions Determined by JP Motor Frame, Dimensiones determinadas por el armazón del motor JP

Frame, Armazón	A	AB Ref.	B	C Ref.	D	E	F	G	H	P Ref.
184JP	8½	5⅞	6⅞	13½	4½	3¾	2¾	¾	13½	7⅞
213JP	9½	7⅞	8	15½	5¼	4¼	3½	7¾		
215JP										
254JP	11¼	8½	11¾	20½	6¼	5	4⅞	¼	17½	12½
256JP										
284JP	12¼	12¼	12¼	23⅞	7	5½	4¾	5½	13½	13½
286JP										
324JP	13¾	13¾	13¾	25½	8	6½	5¼	5/8	15⅞	15⅞
326JP										
364TCZ	16½	14¾	14½	28	9	7	5⅞	2½	17⅞	17⅞
365TCZ										

Motor Frame Selections, Selecciones del armazón del motor

Motor Frame, Armazón del motor	Motor Horsepower, Potencia del motor								Motor Wt. (lbs.) Peso motor (lib.)
	3500 RPM, 3500 RPM				1750 RPM, 1750 RPM				
	1Ø, Monofásicos		3Ø, Trifásicos		1Ø, Monofásicos		3Ø, Trifásicos		
	ODP	TEFC	ODP	TEFC	ODP	TEFC	ODP	TEFC	
145JP	—	—	—	—	—	—	2	2	41
182JP	3	3	5	3	2	2-3	3	3	77
184JP	5	5	7½	5	3	—	5	5	97
213JP	7½	—	10	—	5*	—	7½	7½	122
215JP	10	—	15	10, 15	5, 10	—	10	10	155
254JP	—	—	20	—	—	—	15	15	266
256JP	—	—	25	20	—	—	20	20	320
284JP	—	—	30	25	—	—	25	25	392
286JP	—	—	40	30	—	—	30	30	422
324JP	—	—	50	40	—	—	40	40	520
326JP	—	—	60	50	—	—	50	50	600
364TCZ	—	—	75	60, 75	—	—	60	60	750
365TCZ	—	—	100	100	—	—	75	75	804

* 213TCZ

SFH Close Coupled – Materials of Construction
SFH Acoplamiento compacto – Materiales de construcción

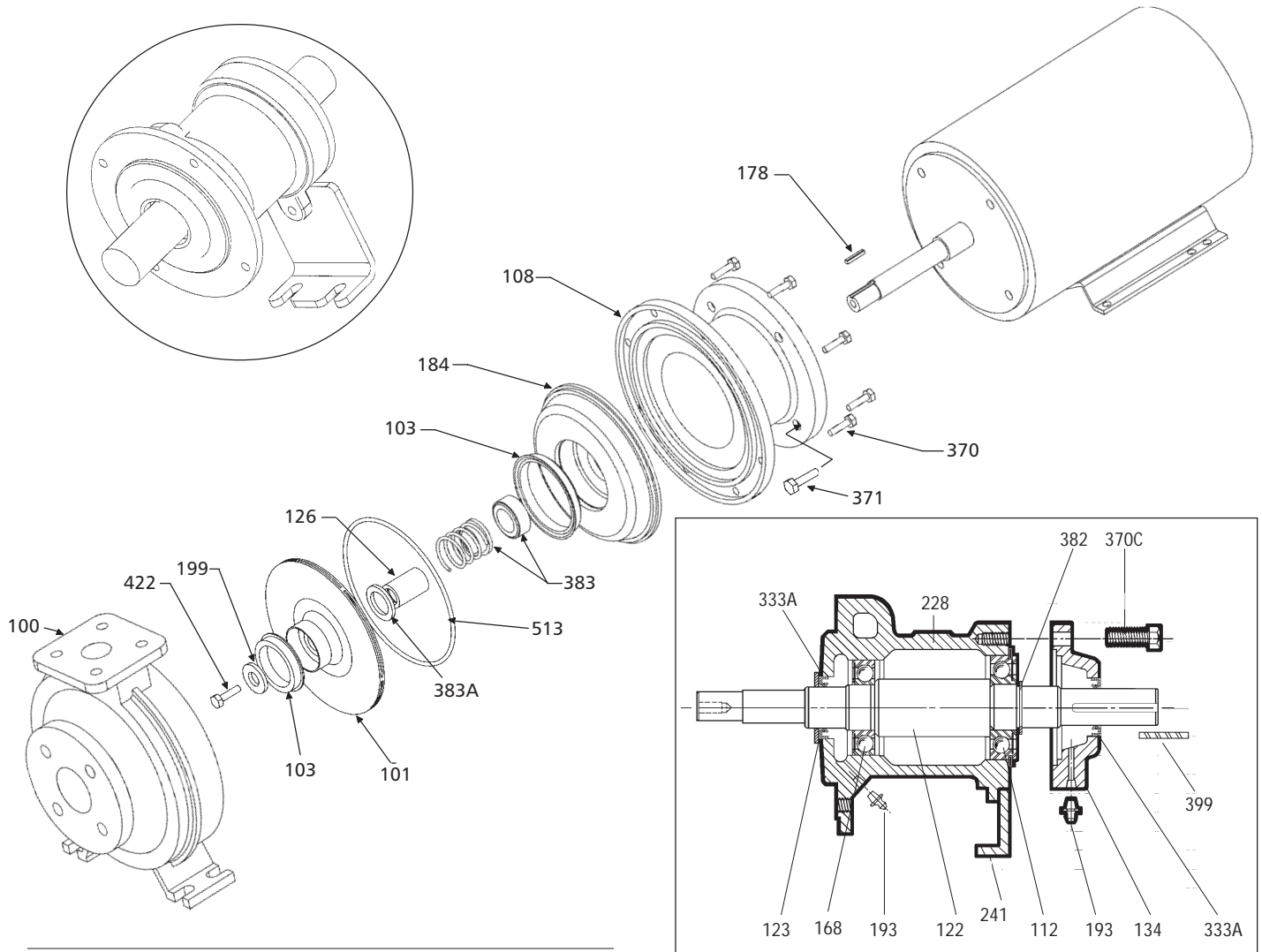

Item No., Parte No.	Description, Descripción	Materials, Materiales
100	Casing, Carcasa	Cast Iron, Hierro fundido
101	Impeller, Impulsor	316L SS (S-Group), Cast Iron (22, 23, 27, 28) Acero inox. 316L (Grupo S), Hierro fundido (22, 23, 27, 28)
103	Wear ring, Anillo de desgaste	316L SS, Acero inox. 316L
184	Seal housing, Alojamiento del sello	Cast Iron, Hierro fundido
178	Impeller key, Chaveta del impulsor	Steel, Acero
126	Shaft sleeve, Camisa del eje	316 SS, Acero inox. 316
422	Impeller Bolt, Perno del impulsor	304 SS, Acero inox. 304
199	Impeller washer, Arandela del impulsor	
370	Casing bolt (casing to adapter), Tornillo de casquete de la carcasa (carcasa al adaptador)	Carbon Steel, Plated, Ac. al carbón, enchapado
108	Adapter, Adaptador	Cast iron, Hierro fundido
371	Hex head cap screw (adapter to motor), Tornillo de cabeza hexagonal (adaptador al motor)	Carbon Steel, Plated, Ac. al carbón, enchapado
513	O-ring casing, Anillo en O carcasa	BUNA-N (standard, estándar)
383	Mechanical seal, Sello mecánico	See seal chart, page 3 Ver tabla del sello, pagina 3

Item No., Parte No.	Description, Descripción	Materials, Materiales
383A	Retainer, Seal Spring, Retén, resorte del sello	304 SS, Acero inox. 304
112	Ball Bearing (Outboard), Cojinete de bolas (exterior)	Steel, Acero
122	Shaft, Eje	Steel, Acero
123	Deflector, Deflector	BUNA-N
134	Bearing Cover, Tapa del cojinete	Cast Iron, Hierro fundido
168	Ball Bearing (Inboard), Cojinete de bolas (interior)	Steel, Acero
193	Grease Fitting (M-Group only), Grasera (Grupo M solamente)	Steel, Acero
228	Bearing Frame, Armazón del cojinete	Cast Iron, Hierro fundido
333A	Lip Seal, Sello de reborde	BUNA / Steel, Acero
370C	Hex Head Cap Screw, Tornillo de casquete de cabeza hexagonal	Steel SAE Gr. 5
382	Retaining Ring, Anillo de retención	Steel SAE Gr. 5
241	Foot, Frame, Pata, armazón	Steel, Acero
399	Key, Frame, Chaveta, armazón	Steel, Acero

**SFH M & S-Group Frame Elevation – Dimensions and Weights,
SFH Elevación del armazón, Grupos M y S – Dimensiones y pesos**

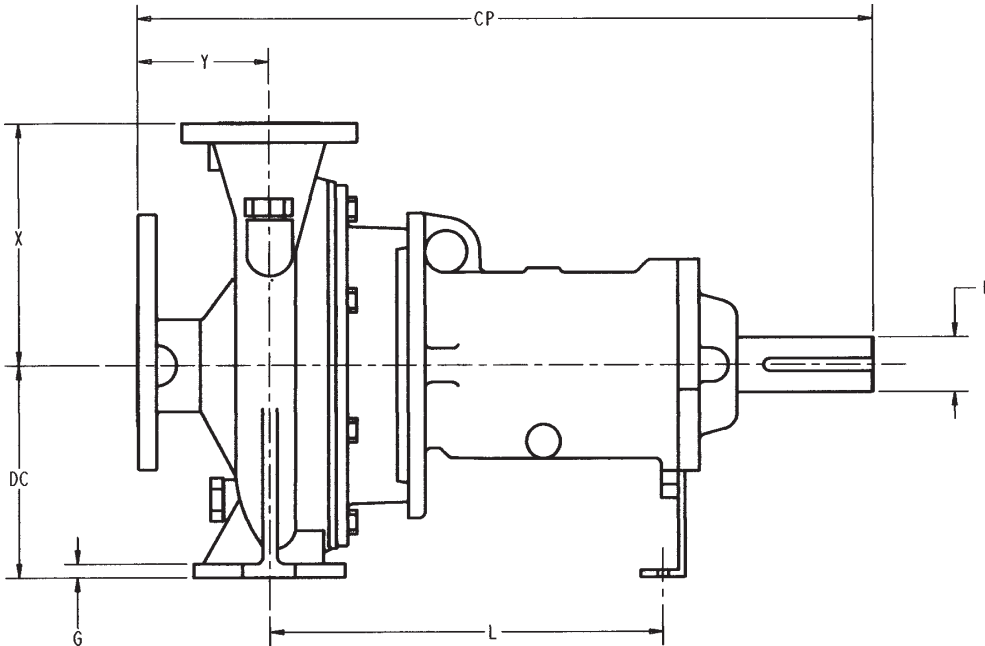

(All dimensions in inches and weights in lbs.
Do not use for construction purposes.)
(Todas las dimensiones en pulgadas y los pesos en libras. No usar para propósitos de construcción.)

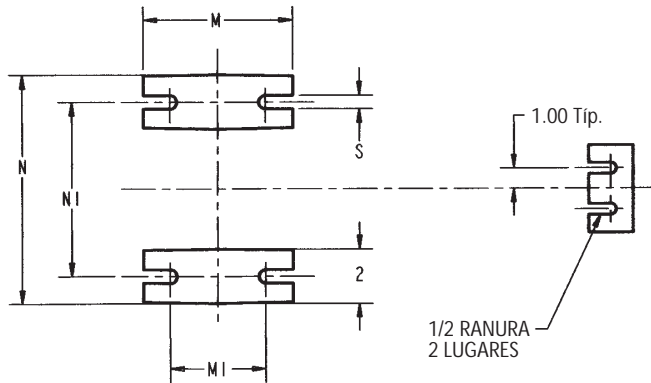

NOTES:

1. ALL dimensions in inches.
2. Motor dimensions may vary with motor manufacturer.
3. Not for construction purposes.

NOTAS:

1. TODAS las dimensiones en pulgadas.
2. Las dimensiones puede que varíen con los fabricantes.
3. No usar para propósitos de construcción.

Pump, Bomba	Suction Succ. ①	Discharge Desc. ①	X	Y	L	N	N1	M	M1	S	G	DC	CP	U	
4SF	2½	1½	6.19	3.12	10.60	9.44	7.50	3.94	2.75	.56	.50	5.19	19.12	1½	
5SF		2	7.06	3.94		10.44	8.31					6.31	19.94		
7SF		1½	7.75	6.19		7.50	5.19					19.12			
8SF		2	7.06	7.06		6.31	19.12								
9SF	2	1½	6.19	3.12	10.98	9.44	7.50	4.92	3.75		.56	.56	7.08	20.92	1½
10SF			7.06	7.06		6.31	19.12								
11SF	3	2½	8.75	3.82	14.60	12.59	9.84	6.29	4.72		.71	.62	7.88	24.44	
22SF	4	3	9.72	4.80		13.58	11.02						25.44		
23SF	2	1½	8.75	3.82	14.60	12.59	9.84	6.29	4.72	.71	.62	7.88	24.44		
24SF	2½	2	9.72	4.80		14.17	11.02					25.44			
25SF	3	2½	9.72	4.80		15.75	12.40					25.44			
27SF	3	2½	9.72	4.80	14.60	14.17	11.02	6.29	4.72	.71	.62	7.88	24.44		
28SF	4	3	10.91	4.80		15.75	12.40					25.44			

① For use with ANSI class 125/150 mating flanges.
Para usar con bridas coincidentes ANSI clase 125/150.

SFH S-Group Frame Mounted – Dimensions and Weights, SFH Montado en el armazón, Grupo S – Dimensiones y pesos

(All dimensions in inches and weights in lbs. Do not use for construction purposes.)
(Todas las dimensiones en pulgadas y los pesos en libras. No usar para propósitos de construcción.)

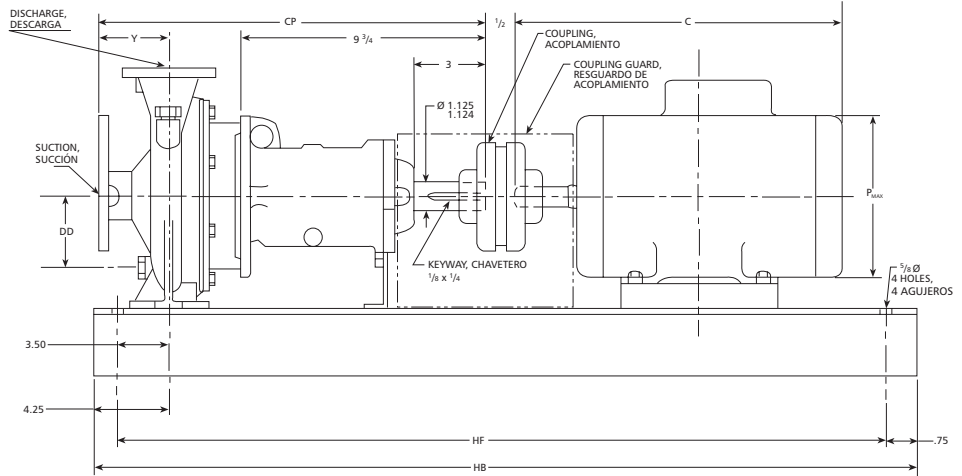
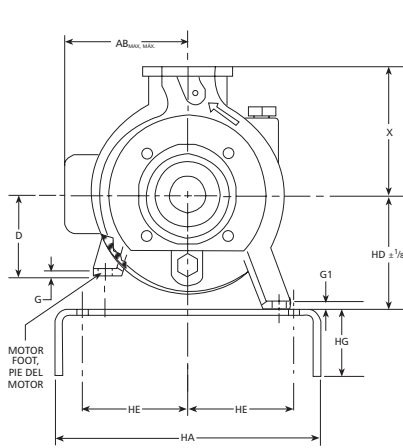

Dimensions Determined by Motor, Dimensiones determinadas por el motor

Frame, Armazón	AB Max., AB máx.	C	D	G	P Max., P Máx.	Wt. (lbs.), Pesos (libras)
143T	5.31	14	3.5	1/8	8	45
145T		14.25				53
182T	6.38	16.63	4.5	3/16	9.5	74
184T		18				95
213T	8.31	20	5.25	7/32	10.75	116
215T						136
254T	11.63	24	6.25	1/4	13	266
256T						264

Dimensions Determined by Pump, Dimensiones determinadas por la bomba

Pump, Bomba	Suction, Succ.	Discharge, Desc.	CP	DD	X	Y	G1	Wt. (lbs.), Pesos (libras)	Pwr. Frm. Wt. (lbs.)
9SF	2	1.25	19.12	4	6.19	3.12	.50	41	75
10SF			19.12	4.75	7.06			69	103
4SF	2.5	1.5	19.12	4	6.19	49		83	
7SF			19.94	4.75	7.06	85		119	
5SF		2	19.94	4.44	7.06	88		122	
8SF			19.94	5	7.75	125		159	
*11SF	2	1.5	20.92	5.75	8.75	3.82	.56	105	139

*11SF assembly uses 14x46 baseplate always. *El conjunto 11SF siempre usa placa base de 14 x 46.

Centerline Dimension, Dimensión de la línea central

Pump, Bomba	HD(± 1/8) Centerline, Línea central Frame Size, Tamaño del armazón	
	140 - 210	250
4SF / 9SF	5.25	6.25
5SF / 7SF / 8SF / 10SF	6.31	6.31
11SF	7.08	7.08

Motor Frame Selections, Selecciones del armazón del motor

Motor Frame, Armazón del motor	Motor Horsepower, Potencia del motor							
	3500 RPM, 3500 RPM				1750 RPM, 1750 RPM			
	1Ø, Monofásicos		3Ø, Trifásicos		1Ø, Monofásicos		3Ø, Trifásicos	
	ODP	TEFC	ODP	TEFC	ODP	TEFC	ODP	TEFC
143T	1/2, 1, 1 1/2	3/4, 1, 1 1/2	1/2, 1, 1 1/2	1/2, 1, 1 1/2	1/2, 3/4	1/2, 3/4	1/2, 3/4, 1	1/2, 3/4, 1
145T	2	2	2 - 3	2 - 3	—	—	2	2
182T	3	3	5	3	2	2 - 3	3	3
184T	5	3 - 5	7 1/2	5	3	—	5	5
213T	7 1/2	—	10	7 1/2	5	—	7 1/2	7 1/2
215T	10	—	15	10 - 15	—	—	10	10
254T	—	—	20	15	—	—	15	15
256T	—	—	25	20 - 25	—	—	20	20

S-Group Dimensions Determined by Baseplate, Grupo S dimensiones determinadas por la placa base

Frame, Armazón	HA (width), HA (ancho)	HB (length), HB (largo)	HE	HF	HG	Baseplate Thickness, Espesor de la placa base	Wt. (lbs.), Pesos (libras)
143T	12	40	5	38.50	2.25	1/4	47
145T							
182T							
184T							
213T	14	46	5	44.50	2.25	1/4	60
215T							
254T							
256T							

NOTE:
1. ALL dimensions in inches.
2. Motor dimensions may vary with motor manufacturer.
3. Not for construction purposes.

NOTA:
1. TODAS las dimensiones en pulgadas.
2. Las dimensiones puede que varíen con los fabricantes.
3. No usar para propósitos de construcción.

SFH M-Group Frame Mounted – Dimensions and Weights, SFH Montado en el armazón, Grupo M – Dimensiones y pesos

(All dimensions in inches and weights in lbs. Do not use for construction purposes.)
(Todas las dimensiones en pulgadas y los pesos en libras. No usar para propósitos de construcción.)

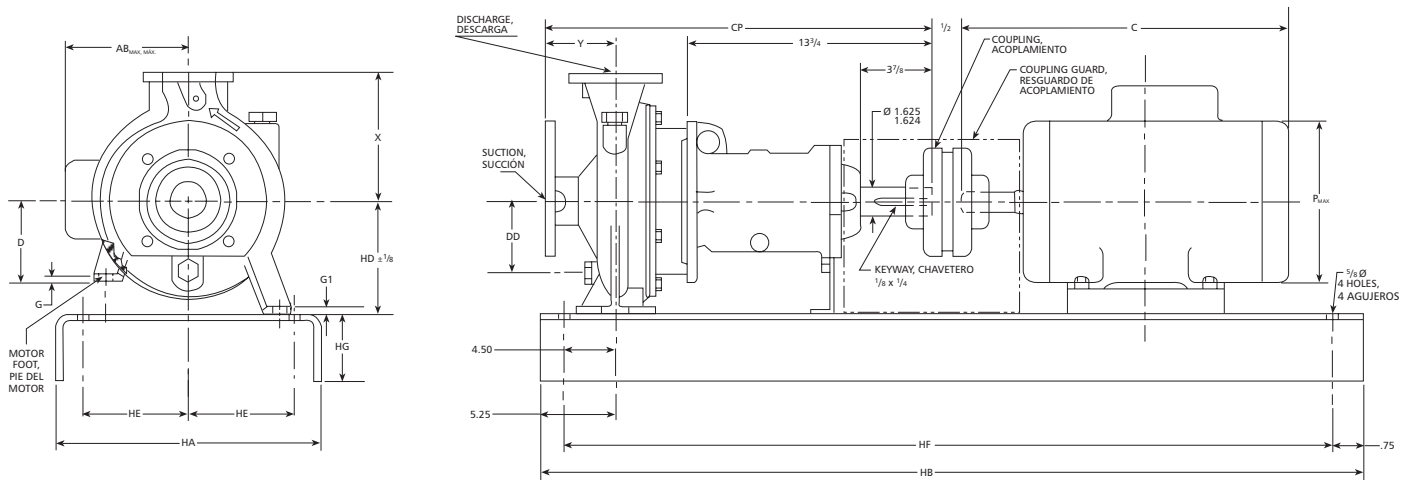

Dimensions Determined by Motor, Dimensiones determinadas por el motor

Frame, Armazón	AB Max., AB Máx.	C	D	G	P Max., P Máx.	Wt. (lbs.), Pesos (libras)
182T	6.38	16.63	4.5	3/16	9.5	74
184T		18				95
213T	8.31	20	5.25	7/32	10.75	116
215T						136
254T	11.63	24	6.25	1/4	13	266
256T						264
284T/TS	12.63	27	7	5/8	15	392
286T/TS						422
324T/TS	14.13	30	8	5/8	17.38	592
326T/TS						634
364T/TS	15.44	34	9	5/8	18.88	834
365T/TS						100

Centerline Dimension, Dimensión de la línea central

Pump, Bomba	HD(± 1/16) Centerline, Línea central		
	Frame Size, Tamaño del armazón		
	180 - 280	320	360
22SF / 23SF / 24SF / 25SF	7.08	8	9
27SF / 28SF	7.88	8	9

M-Group Dimensions Determined by Baseplate, Grupo M dimensiones determinadas por la placa base

Frame, Armazón	HA (width), HA (ancho)	HB (length), HB (largo)	HE	HF	HG	Baseplate Thickness, Espesor de la placa base	Wt. (lbs.), Pesos (libras)
182T/184T	18	46	7.50	44.50	2.25	3/8	110
213T/215T							
254T/256T		52		50.50			
284T/286T							
284TS/286TS				58			
324T/326T							
324TS/326TS							
364T/365T							
364TS/365TS							

M-Group Dimensions Determined by Pump, M-Grupo dimensiones determinadas por la bomba

Pump, Bomba	Suction, Succ.	Discharge, Desc.	CP	DD	X	Y	G1	Wt. (lbs.), Pesos (libras)	Pwr. Frm. Wt. (lbs.)	
24SF	2	1.5	24.45	5.75	8.75	3.82	.56	105	165	
25SF	2.5	2		5.59						
22SF	3	2.5		6.09						
27SF	4	3	25.43	5.72	9.72	4.80	.56	135	195	
23SF				6.50						10.91
28SF				6.50						10.91

Motor Frame Selections, Selecciones del armazón del motor

Motor Frame, Armazón del motor	Motor Horsepower, Potencia del motor							
	3500 RPM, 3500 RPM				1750 RPM, 1750 RPM			
	1Ø, Monofásicos		3Ø, Trifásicos		1Ø, Monofásicos		3Ø, Trifásicos	
	ODP	TEFC	ODP	TEFC	ODP	TEFC	ODP	TEFC
182T	3	3	5	3	2	2 - 3	3	3
184T	5	3 - 5	7 1/2	5	3	—	5	5
213T	7 1/2	—	10	7 1/2	5	—	7 1/2	7 1/2
215T	10	—	15	10 - 15	—	—	10	10
254T	—	—	20	15	—	—	15	15
256T	—	—	25	20 - 25	—	—	20	20
284T/TS	—	—	30	25	—	—	25	25
286T/TS	—	—	40	30	—	—	30	30
324T/TS	—	—	50	40	—	—	40	40
326T/TS	—	—	60	50	—	—	50	50
364T/TS	—	—	75	60	—	—	60	60
365T/TS	—	—	100	75	—	—	75	75

NOTE:
1. ALL dimensions in inches.
2. Motor dimensions may vary with motor manufacturer.
3. Not for construction purposes.

NOTA:
1. TODAS las dimensiones en pulgadas.
2. Las dimensiones puede que varíen con los fabricantes.
3. No usar para propósitos de construcción.

Specifications Especificaciones

Capacities to:

950 GPM (216 m³/hr)
at 3500 RPM
500 GPM (113 m³/hr)
at 1750 RPM

Heads to:

400 feet THD (120 m) at 3500 RPM,
100 feet THD (32 m) at 1750 RPM

Maximum working pressures to:

175 PSI (12 bars)

Maximum temperatures to:

212°F (100°C) with standard seal
or 250°F (121°C) with optional
high temperature seal.

Materials of Construction:

Impellers - 316L SS (S-group)
Cast Iron (22/23/27/28)
Casing and Seal Housing -
Cast Iron

Rotation: Clockwise when
viewed from motor end.

Enclosed impeller and replaceable wear ring:

for high efficiency and maximum
wear life.

Motor (close coupled):

NEMA standard JP shaft open
drip-proof, totally enclosed and
explosion-proof enclosures, 60
Hz, 1750 or 3500 RPM.

Single phase

ODP/TEFC/EXP. (115/230 V)
1750 RPM, ½ – 10 HP.
3500 RPM, ½ – 10 HP.

Three phase ODP/TEFC/EXP.
(208 – 230/460 V).
1750 RPM, ½ – 30 HP
3500 RPM, ½ – 75 HP

NOTE: Overload protection must
be provided. Contactor with
overload for single phase or
starter with heaters for three
phase ordered separately.

Capacidades:

950 GPM (216 m³/hr) a 3500 RPM,
500 GPM (113 m³/hr) a 1750 RPM

Alturas de elevación::

400 pies THD (120 m) a 3500 RPM,
100 pies THD (32 m) a 1750 RPM

Presión de trabajo máxima:

175 PSI (12 bars)

Temperatura máxima:

212°F (100°C) con sello estándar o
250°F (121°C) con sello opcional
para alta temperatura.

Materiales de construcción:

Impulsores – Ac. Inox. 316L
(grupo S)

Hierro fundido (22/23/27/28)

Carcasa y caja del sello – hierro
fundido

Rotación: En el sentido de las
agujas del reloj visto desde el
extremo del motor.

Impulsor encerrado y anillo de desgaste reemplazable:

para alta eficiencia y máxima
durabilidad.

Motor (acoplamiento compacto):

Eje abierto a prueba
de goteo JP estándar NEMA,
totalmente encerrado y recintos a
prueba de explosión, 60 Hz, 1750
ó 3500 RPM.

Monofásicos

ODP/TEFC/EXP. (115/230 V)
1750 RPM, ½ – 10 HP.
3500 RPM, ½ – 10 HP.

Trifásicos ODP/TEFC/EXP.
(208 – 230/460 V).

1750 RPM, ½ – 30 HP
3500 RPM, ½ – 75 HP

NOTA: Se debe de proporcionar
protección térmica contra
sobrecarga. Contactor con
protección térmica contra
sobrecarga para monofásicos o
arrancadores con calentadores para
trifásicos se piden por separado.

Goulds Pumps is a brand of ITT Water Technology, Inc.
- a subsidiary of ITT Industries, Inc.

Goulds Pumps, G&L Pumps and the ITT Engineered Blocks Symbol
are registered trademarks and tradenames of ITT Industries.

*Goulds Pumps son una marca de fábrica de ITT Water Technology,
Inc. - un subsidiario de ITT Industries, inc.*

*Goulds Pumps, G&L Pumps y el símbolo ITT Engineered Blocks son
marcas registradas y marcas comerciales de ITT Industries.*