

AQUAVAR®

Variable Speed
Pump Control

Installation Programming & Operation



Models covered:

02501271 2.1 - 2HP - single phase
02501281 2.2 - 3HP - single phase
02501311 3.4 - 5HP - three phase
02501321 3.5 - 7.5HP - three phase
02501331 3.7 - 10HP - three phase
02501341 3.11 - 15HP - three phase

hardware revision (E)
software revision 120



Goulds Pumps



ITT Industries

AQUAVAR Controller Owner's Information Record

AQUAVAR Controller Model _____ Transducer Model _____
AQUAVAR Serial Number _____ Transducer Rating _____
Date purchased _____
Purchased from _____

Pump Model _____ Software Version _____
Pump Code Number _____





Program Record

Please use the following to record the final values programmed into the AQUAVAR controller after installation.

Required Value _____ (select) Intensity 1 _____ (%)
Autostart _____ (on/off) Intensity 2 _____ (%)
Password _____ (value) Pressure Increase _____ (PSI)
Window _____ (%) Pressure decrease _____ (PSI)
Ramp Hysteresis _____ (%) Enable Sequence Control _____ (Hz)
Ramp 1 _____ (seconds) Switch Interval _____ (hours)
Ramp 2 _____ (seconds) Optional Value _____
Ramp 3 _____ (seconds) Synchron Limit _____ (Hz)
Ramp 4 _____ (seconds) Synchron Window _____ (Hz)
Max. Frequency _____ (Hz) Pump Address _____ (# or off)
Min. Frequency _____ (Hz) ADC Reference _____ (select)
Config. F Min. _____ Freq. Lifting _____ (Hz)
Stop - Delay F Min. _____ (seconds) Lift Intensity _____ (%)
Boost _____ (%) Analog out _____ (select)
Sensor Curve _____ Pressure Unit _____ (select)
Sensor Normalize - 20mA _____ (PSI) Test Run After _____ (in hours)
Mode _____ (select) Test Frequency _____ (Hz)
Regulation Mode _____ Test Boost _____ (%)
Start Value _____ (%) Conveyor Limit _____ (PSI)
Config. Second Value _____ Delay Time _____ (seconds)
Relay Config. _____ Error Reset _____ (on/off)
Offset Input _____ Display Contrast _____ (%)
Level 1 _____ (%) Lock Function _____ (on/off)
Level 2 _____ (%) Heating _____ (on/off)

Index

Index

	System Design	5
	Important Safety Instructions	6
	Installation Procedures	9
	Materials Checklist	9
	1. Mounting the AQUAVAR Controller	10
	2. Dimensions and Weights	11
	3. Electrical Connections	12
	4. Wiring the AQUAVAR Controller to Motor	13
	5. Pump Priming	20
	6. Run Test	20
	Programming	22
	1. The Main Menu - Setting One Pump Constant Pressure	22
	2. Single Pump - Pump Protection	25
	• To Set Run-Out Protection	25
	• To Set Low/No Flow Protection	26
	3. Single Pump - System Curve Compensation	29
	• Entering Compensation Values	30
	• Circulator Applications	32
	4. Single Pump Constant Flow	32
	5. Single Pump - Level Control Applications	34
	6. Single Pump - Submersible	35
	7. Setting a Second Required Value	37
	8. Variable Second Required Value	39
	9. Multiple Pump Constant Pressure - Slave Pump	43
	10. Multiple Pump Constant Pressure and System Curve Compensation	46
	11. Multiple Pump - Pump Protection	52
	• To Set Low/No Flow Protection	52
	Operator Custom Features and Displays	54
	• Jog Mode	54
	• Window	54
	• Ramp Hysteresis	54
	• Ramp Settings	54
	• Ramp 1-4	55
	• Maximum Frequency	55
	• Minimum Frequency	56
	• Config. F Min	56
	• Stop-Delay F Min	56
	• Boost	56
	• Sensor Adjustment	56
	• Sensor Curve	56
	• Mode	56
	• Start Value	57
	• Config. Required Value 2	57
	• Relay Config.	57
	• Submenu Offset	57
	• Regulation Mode	58
	• Submenu Sequence Control	58

Index

Index (*continued*)



Operator Custom Features and Displays (*continued*)

• Actual Value Increase	58
• Actual Value Decrease	58
• Enable Sequence Control	58
• Switch Interval	58
• Source Required Value	58
• Submenu Synchronous Control	58
• Synchronous Limit	58
• Synchronous Window	58
• Pump Sequence	59
• Bus	59
• Pump - Address	59
• ADC Reference	59
• Frequency Lifting	59
• Lift Intensity	60
• Reference	60
• Analog Out	60
• Pressure Units	60
• Test Run	60
• Submenu Test Run Manual	60
• Submenu Errors	60
• Clear Errors	61
• Operating Hours	61
• Total Run Time	61
• Display Contrast	61
• Set Password	61
• Lock Functions	62
• Heating On	62
• Default Values	62
• Save ??	62



Repair of Faults and Errors

• Lack of Water	63
• Conveyor Control	63
• Overtemp Motor	63
• Overtemp Inverter	63
• Over Voltage	63
• Under Voltage	63
• Overloaded	64
• Earth Fault	64
• Pressure Sensor Error	64
• Error 1-8	64



Programming Flow Chart

	65
--	----



Help Windows

	66
--	----

Appendix A - Pressure Transducer Data	71
Appendix B - AQUAVAR Controller Drive Head Technical Data and Terminals	74
Appendix C	77
Appendix D	79
Technical Data - Frequency Inverter	80

System Design

System Design - Typical Constant Pressure Systems

Note

Systems MUST be designed by qualified technicians only.

The following diagrams show typical single pump and multi-pump systems using the AQUAVAR controller. Connection can be made directly to a water supply or water can be drawn from a supply tank or well. In the case of supply tanks and wells, level switches, (item 10) can be used to shut down the pumps when water is low. In the direct connection, a pressure switch on the suction side (item 8) can be used.

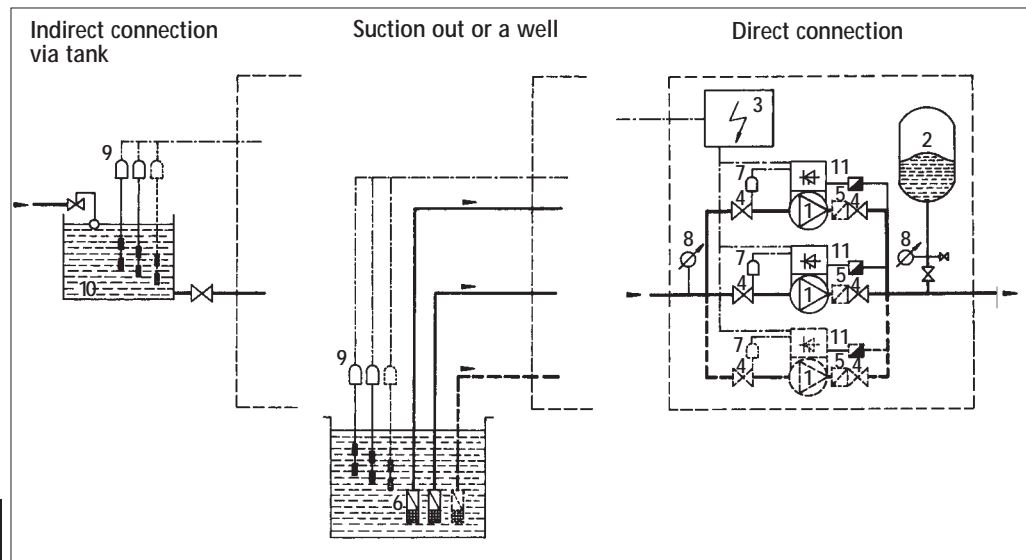

Diagram 1
Multiple Pump Layout

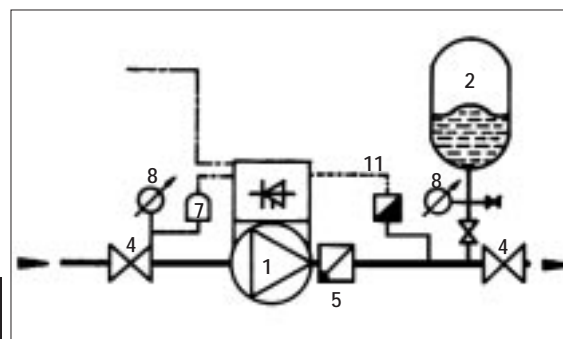

Diagram 2
Single Pump Layout

- 1 Pump with AQUAVAR controller
- 2 Diaphragm tank
- 3 Distribution panel
- 4 Gate valves
- 5 Check valves
- 6 Foot valves
- 7 Incoming pressure switch
- 8 Pressure gauges
- 9 Level switches
- 10 Supply tank
- 11 Pressure transmitter

A diaphragm pressure tank is used on the discharge side of the pump or pumps to maintain pressure in the line when there is no demand. This will keep the pumps from continuing to run. With the AQUAVAR controller control unit, it is not necessary to have a large tank for supply purposes. In selecting a tank, make sure it can withstand maximum system pressure. The tank should have a capacity of about 10% of the maximum system flow rate in gpm. Pre-charge the tank to the following:

PSI Set Pressure	15	30	45	60	75	90	105	120	135	150
PSI Tank Pre-charge	12	21	37	52	64	77	95	117	125	138

Note

Closed loop circulator systems may not require a pressure tank.

! Safety Instructions



Important: Read all safety information prior to installation of the AQUAVAR controller.

Notice



This is a **SAFETY ALERT SYMBOL**. When you see this symbol on the pump or in the manual, look for one of the following signal words and be alert to the potential for personal injury or property damage.



Warns of hazards that **WILL** cause serious personal injury, death, or major property damage.



Warns of hazards that **CAN** cause serious personal injury, death, or major property damage.



Warns of hazards that **CAN** cause personal injury or property damage.

NOTE

Indicates special instructions which are very important and must be followed.

1. This manual is intended to assist in the installation, operation, and repair of the AQUAVAR controller and must be kept with the AQUAVAR controller.

Note

All operating instructions must be read, understood, and followed by the operating personnel. Goulds Pumps accepts no liability for damages or operating disorders which are the result of non-compliance with the operating instructions. When in doubt, call for assistance.

2. To avoid serious or fatal personnel injury or major property damage, read and follow all safety instructions in this manual.

Safety Instructions

Safety Instructions

3. Installation and maintenance **MUST** be performed by properly trained and qualified personnel.
4. Review all instructions and warnings prior to performing any work on the AQUAVAR controller.
5. Any safety decals **MUST** be left on the AQUAVAR controller unit and pump.

Note

Inspect AQUAVAR controller for any damage after unpacking from shipping crates. Report any damage immediately to the carrier or distributor/dealer immediately.

6. In addition to instructions contained in this manual, you must meet any local safety, electrical, or plumbing codes and requirements. Installation, maintenance, or repair work must only be carried out by trained, skilled, and qualified personnel, using proper protective gear and tools.
7. **The AQUAVAR controller drive head must be disconnected from the main power supply before attempting any operation in the electrical or mechanical part of the system.**

Note

When in operation, the motor can be stopped, but power remains at the drive head. The motor and pump could start unexpectedly and produce serious injury. When the AQUAVAR controller drive head is connected to the main power supply, the inverter power supply and master control unit are also connected to the power supply.



WARNING!

FAILURE TO DISCONNECT ELECTRICAL POWER BEFORE ATTEMPTING ANY MAINTENANCE CAN CAUSE SHOCK, BURNS, OR DEATH.

Safety Instructions

Note

TOUCHING THESE COMPONENTS SERIOUSLY ENDANGERS LIFE! Voltages of up to 800 volts are possible (higher if there is a fault).

Before removing the AQUAVAR controller drive top cover, the system must be disconnected from the main power supply. After switching off the power supply, you must wait at least 5 minutes before starting work on or inside the AQUAVAR controller drive head. This allows the capacitors in the circuit to be discharged by the discharge resistors.

8. The AQUAVAR controller has electronic safety devices which will stop the motor in the event of electrical or thermal faults. **This does not remove power to the AQUAVAR controller control head.**



WARNING!

FAILURE TO DISCONNECT AND LOCKOUT ELECTRICAL POWER AND WAIT FIVE MINUTES FOR CAPACITOR DISCHARGE BEFORE SERVICING AQUAVAR CONTROLLER CAN CAUSE SHOCK, BURNS, OR DEATH.

Note

Care must be taken when connecting external control wires and jumpers to avoid short circuit to neighboring components.

9. The system must be properly grounded before being put into operation.
10. High voltage tests of the AQUAVAR controller inverter may damage the electronic components. Before carrying out such a test, bridge the incoming and outgoing terminals L1 - L2 - L3 - U - V - W. Isolate the motor from the AQUAVAR controller drive to avoid incorrect capacitor metering inside the AQUAVAR controller.

Note

Repair of electrical faults can lead to the automatic restart of the motor and pump. You must remove all main line power to the AQUAVAR controller before attempting to correct a fault.

Installation Procedures

Step 1- Identify Materials

The following materials are provided with the AQUAVAR controller. Please familiarize yourself with each prior to installation.

Part	Quantity
1. AQUAVAR Controller	1
2. Fan Cover Assembly	
a. Screw M5x60	3
b. Motor mounting clamp	4
3. Pressure Transducer Assembly	1
a. Pressure transducer (1/4" NPT)	1 (new style)
b. Transducer cable gland	1
c. Pressure transducer cable 9 ft.	
d. Optional 30 ft. transducer cord - (available as a separate part only)	

Components Included:

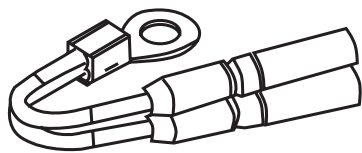

Thermal Resistor

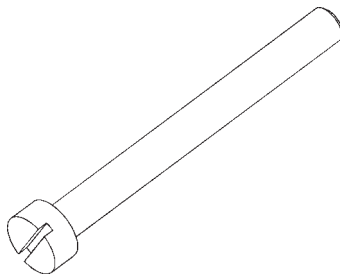

2a

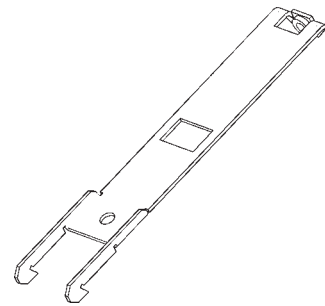

2b

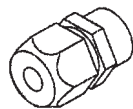

3b

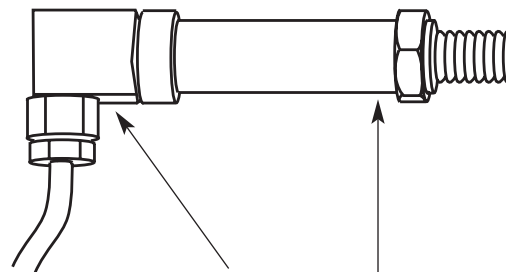

3c or 3d

3a

Diagram 3

Installation Procedures

Step 2 - Mounting the AQUAVAR controller:

WARNING

THE AQUAVAR CONTROLLER DRIVE HEAD AND PUMP MUST BE TOTALLY DISCONNECTED FROM ALL POWER SUPPLY SOURCES BEFORE BEGINNING INSTALLATION OR REPAIR.



WARNING!

FAILURE TO DISCONNECT ELECTRICAL POWER BEFORE ATTEMPTING ANY MAINTENANCE CAN CAUSE SHOCK, BURNS, OR DEATH.

1. The AQUAVAR controller drive head is supplied with all mounting hardware.
2. Remove the 3 screws from the AQUAVAR cover.
3. Place the center bit in the AQUAVAR heat sink.
4. Place the AQUAVAR on the motor.
5. Hang the 4 clamps by the heat sink and mount with the 4 screws.
6. Mount the cover with the 3 screws (remember to use the gaskets).
7. Depending on pump orientation, the display can be rotated 180°.

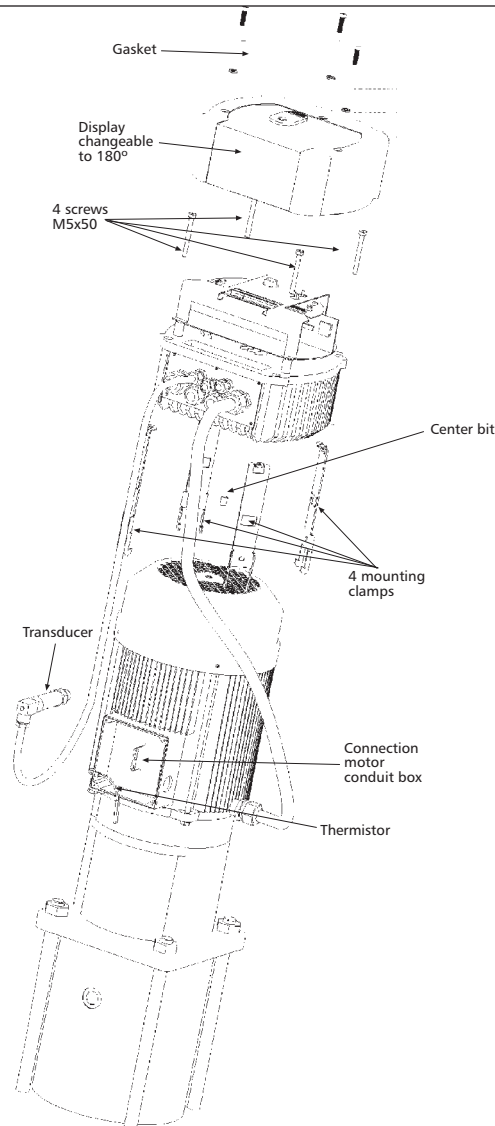

Diagram 4

AQUAVAR Dimensions and Weights

Instructions: Use this supplement for installation and wiring of AQUAVAR models.

Dimension Table:

Type	A	B	C	Weight
04168321	100	185	195	12 lbs.
04168331	100	185	195	12 lbs.
04168371	100	185	195	12 lbs.
04168491	100	185	280	22 lbs.
04168501	100	185	280	22 lbs.
04168511	100	185	280	22 lbs.

Dimensions in (mm)

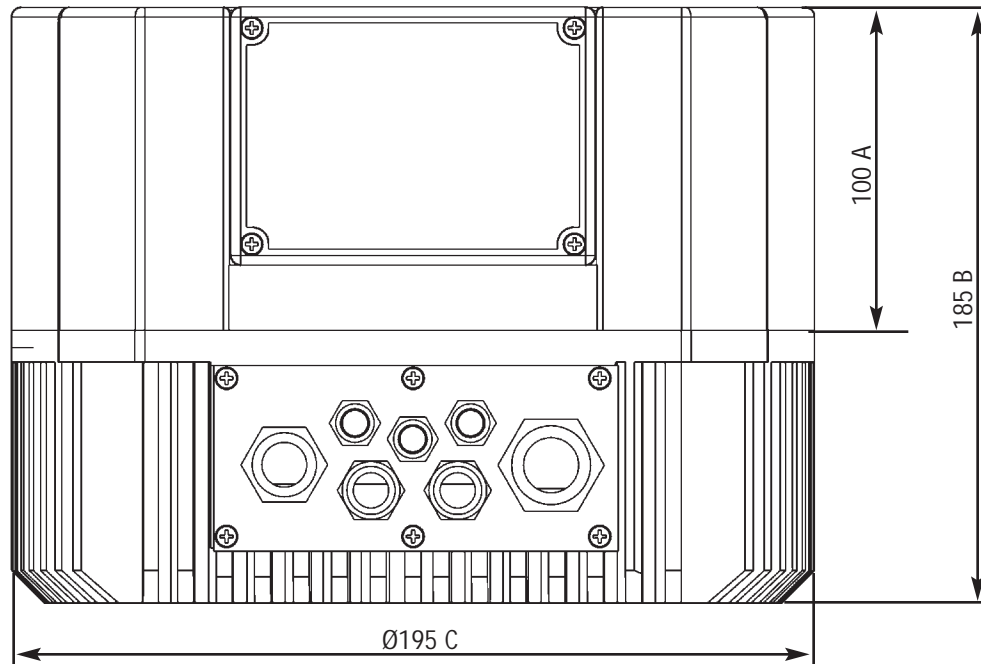

Installation Procedures

Electrical Connections



WARNING!

FAILURE TO DISCONNECT AND LOCKOUT ELECTRICAL POWER AND WAIT FIVE MINUTES FOR CAPACITOR DISCHARGE BEFORE SERVICING AQUAVAR CONTROLLER CAN CAUSE SHOCK, BURNS, OR DEATH.

Note

Installation and maintenance must only be performed by properly trained and qualified personnel equipped with the proper tools.



WARNING!

! INSTALL, GROUND, AND WIRE ACCORDING TO LOCAL AND NATIONAL ELECTRICAL CODE REQUIREMENTS.

! INSTALL AN ALL LEG DISCONNECT SWITCH NEAR THE MOTOR.

! DISCONNECT AND LOCKOUT ELECTRICAL POWER BEFORE INSTALLING OR SERVICING.

ELECTRICAL SUPPLY MUST MATCH PUMP'S AND AQUAVAR CONTROLLER NAME PLATE SPECIFICATIONS. INCORRECT VOLTAGE OR WIRING CAN CAUSE FIRE DAMAGE, AND VOIDS WARRANTY.

MOTORS WITH AUTOMATIC THERMAL PROTECTION MAY OPEN THEIR ELECTRICAL CIRCUIT WHEN A THERMAL OVERLOAD EXISTS. THIS CAN CAUSE THE MOTOR TO START UNEXPECTEDLY AND WITHOUT WARNING.

Installation Procedures

Electrical Connections continued

Step 3 - Wiring the AQUAVAR controller to motor

(Parts in the electrical fittings package will be required for this procedure.) Refer to Diagram 5 before proceeding.

Note: All connections to the AQUAVAR controller are the same for both motor mount and wall mount options.

1. Remove the three screws holding the top of the AQUAVAR controller. Carefully lift off the cover of the AQUAVAR controller.
2. Remove the screw holding the ground wire to the inside of the top of the AQUAVAR controller. Set cover aside.

3. Motor Lead Connections

Locate the terminal block labeled

U, V, W, and ground screw inside the AQUAVAR controller (Diagram 5).

Connect wires to terminal block and route wires through one of the ports on the bottom half of the AQUAVAR controller. (Refer to Diagram 5).

Installation Procedures

Wiring Procedure

- Single Phase Connections
(2 and 3 HP)

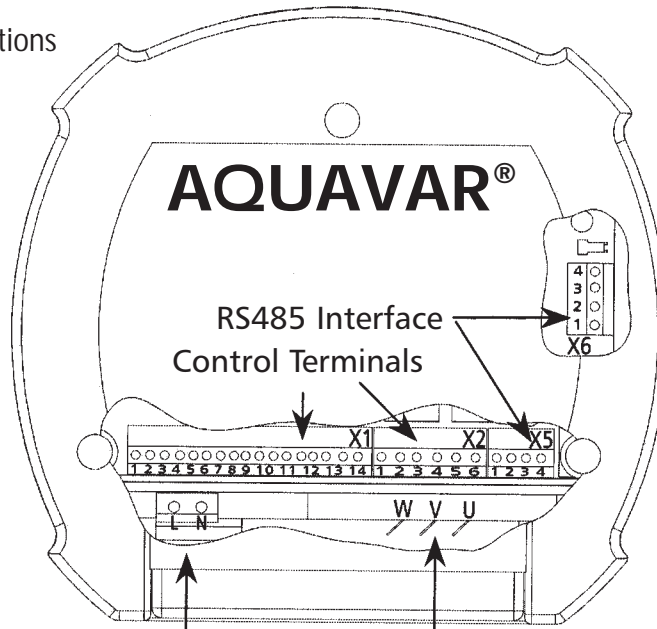

Power Supply
1x230 VAC
L=L₁, N=L₂

Motor Connection
3 Phase Out
U, V, W

- Three Phase Connections
(5 through 15 HP)

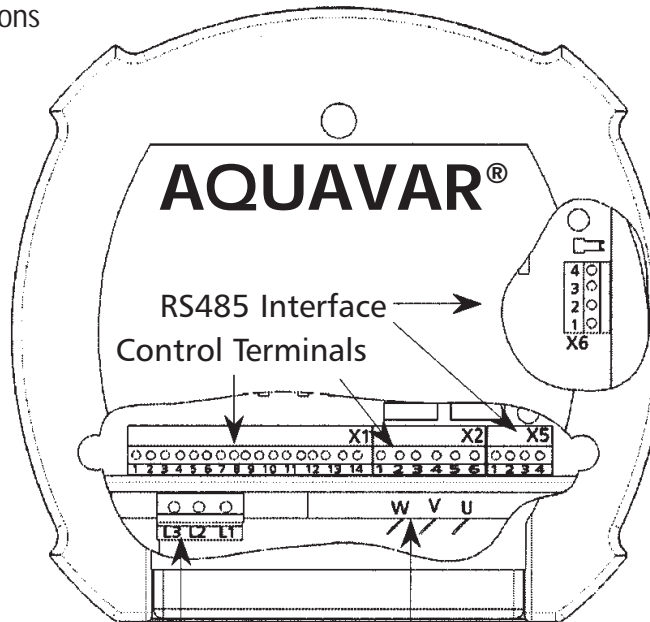

Power Supply
3x400 VAC
L₁, L₂, L₃

Motor Connection
3 Phase Out
U, V, W

Diagram 5

Installation Procedures

Electrical Connections continued

Note

At this time, reference terminal block X1 locations, X1 #7 and #6, and X1 #5 and #4. If these connections are not being used for a low water switch or an external switch, they must be jumped as shown on Diagram 6.

Note

Use two core shielded cables for the thermal sensor and approved UL shielded wire power cable for the motor.

4. Thermal Sensor Wire Connections

Locate the terminal block labeled X1 inside the AQUAVAR controller.

- Connect wires in terminal locations X1 #9 and #8 and route through the same threaded port as the previous wires.

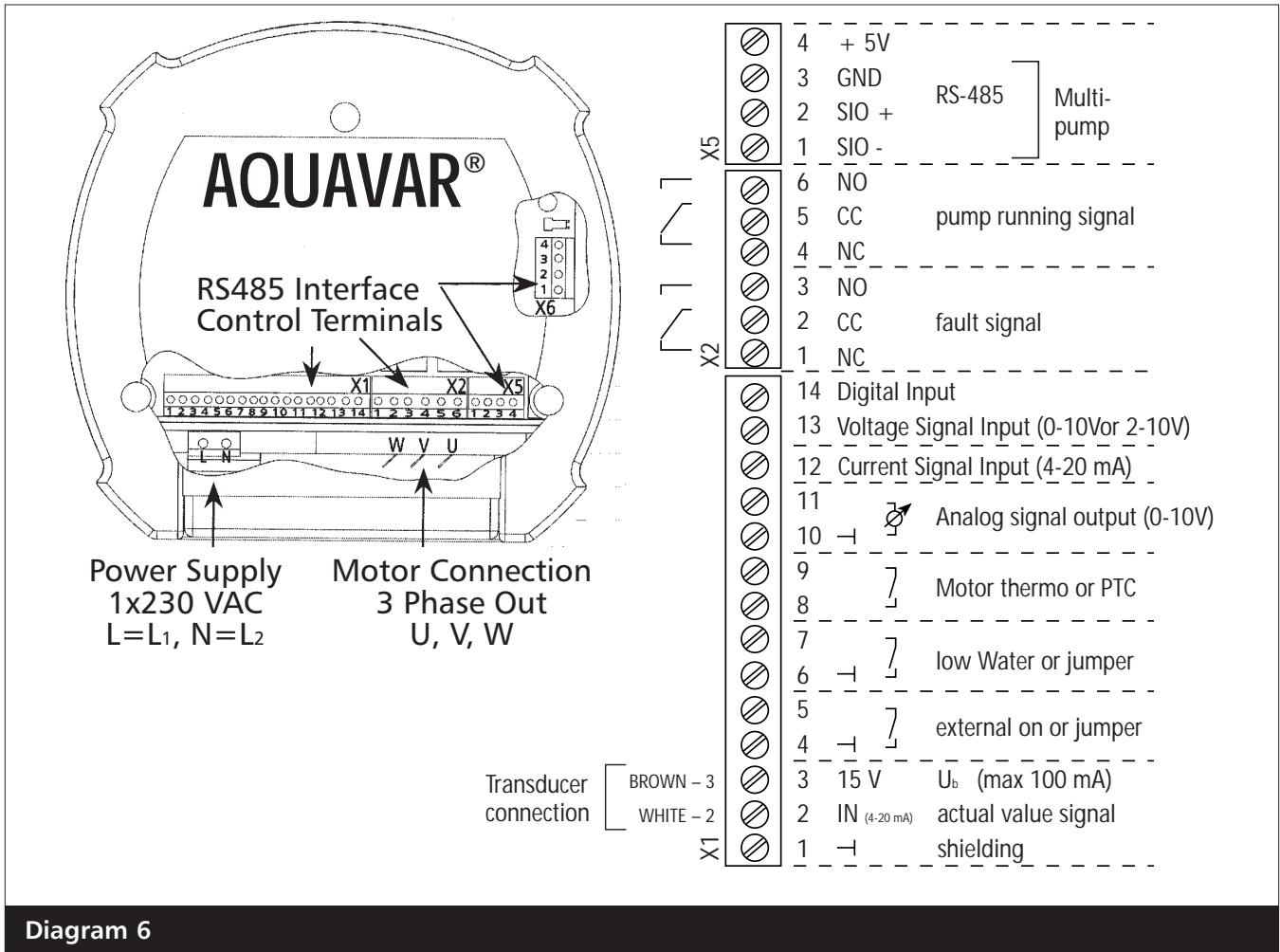

Diagram 6

Installation Procedures

Electrical Connections continued

5. Connections in Conduit Box

Now that the wires have been routed through the port in the AQUAVAR controller.

- Conduit and wires should be trial routed and cut to length at this time. After wire is routed through, insert connector through hole in conduit box and fasten with locknut.

6. Mount the thermistor into the conduit box so the metal side of the sensor will contact the motor shell when mounted.

7. The 4 remaining wires routed from the terminal block U, V, W, and ground screw, should now be connected to the motor leads using the motor nameplate. See Diagram 7 for reference.

- Always check with motor manufacturer for actual motor wiring!

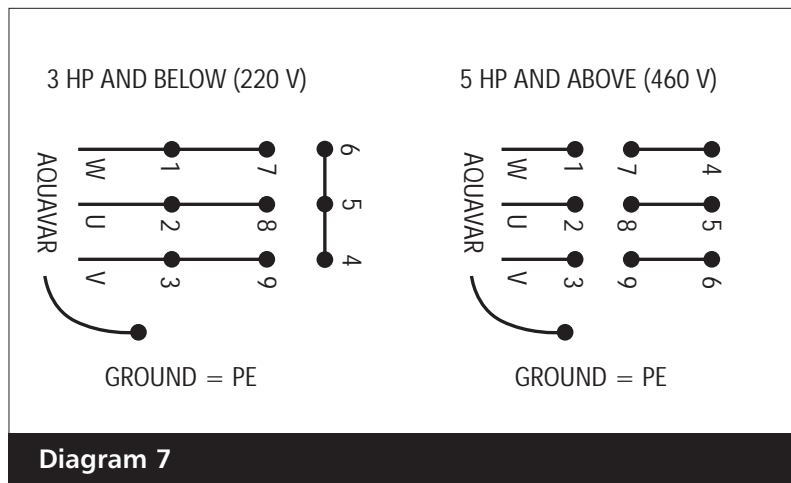

Diagram 7

Note

Use 2 core shielded cable for the heat sensor and approved wire for the motor connections and the input power connections. VFD type shielded power cable is recommended.

8. Pressure Transducer Installation and Wiring

It is recommended that the transducer be mounted in the discharge piping. The location should be in a non-turbulent, straight piece of pipe. See layout on page 5.

9. Place the square gasket over the end of the transducer, plug the cable connector on, and tighten the screw.

Note

Cable connector will fit on one way only! Do not force on or damage may occur.

- The transducer is supplied with NPT threads for direct mounting in the discharge piping.

Installation Procedures

Electrical Connections continued

10. Now select one of the ports in the AQUAVAR controller to route the transducer cable. Cut to length and connect to locations X1 #2 and #3 as shown in Diagram 8. The brown wire is connected to X1 #3 and the white wire to X1 #2. Tighten strain relief.

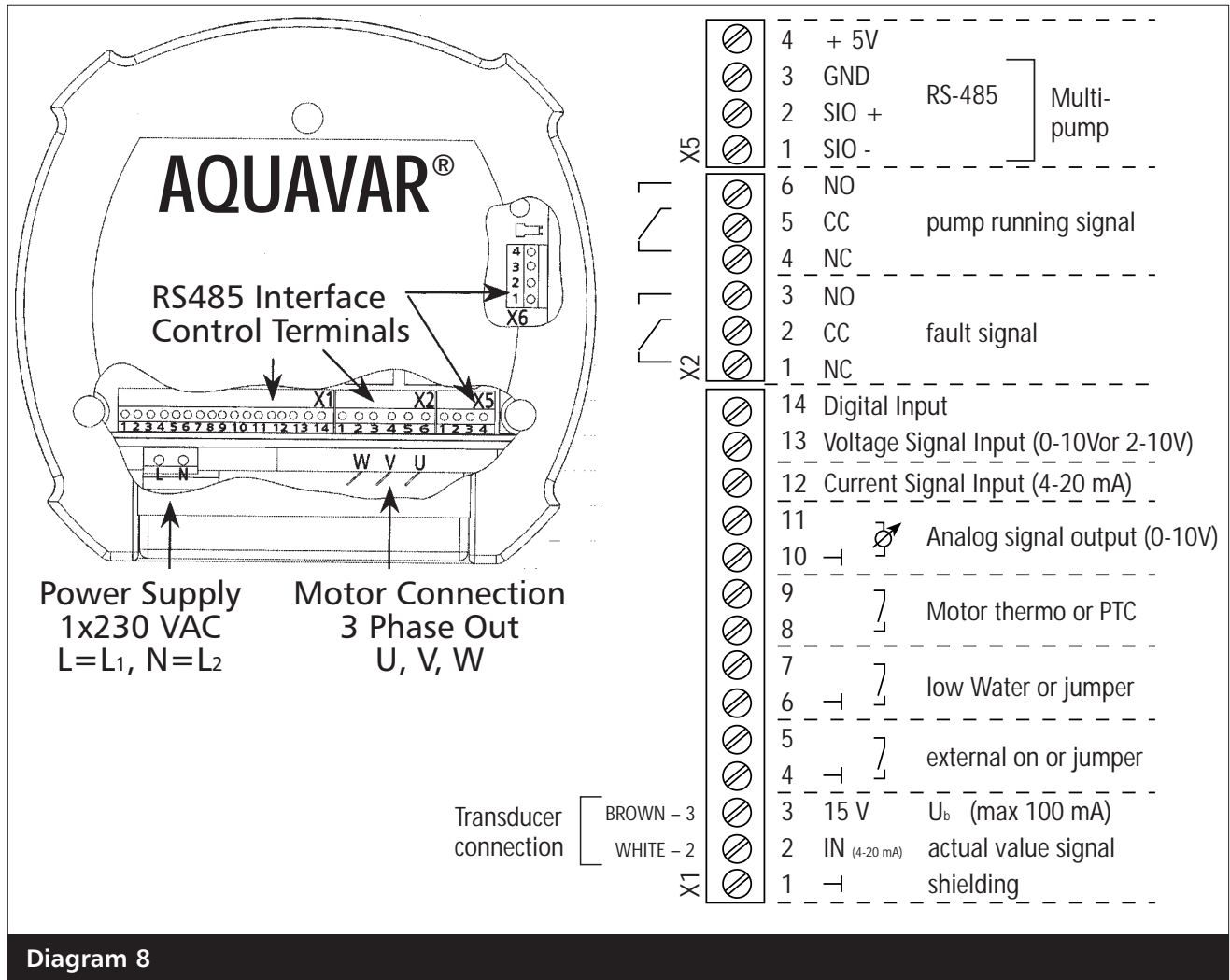

Diagram 8

11. Input Power Cable Installation

The main power cable is connected to the terminal block labeled L1, L2 (N) for the 230 volt 1phase input power units, and labeled L3, L2, and L1 for the 460 volt 3 phase input power units; refer to Diagram 9.

12. Select one of the ports in the AQUAVAR controller to route the input power cable.

Installation Procedures

Wiring Procedure

- Single Phase Connections
(2 and 3 HP)

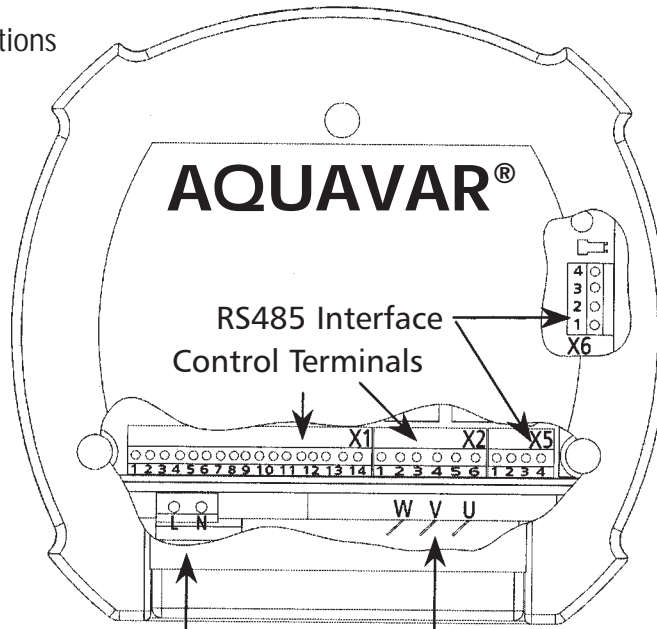

Power Supply
1x230 VAC
L=L₁, N=L₂

Motor Connection
3 Phase Out
U, V, W

- Three Phase Connections
(5 through 15 HP)

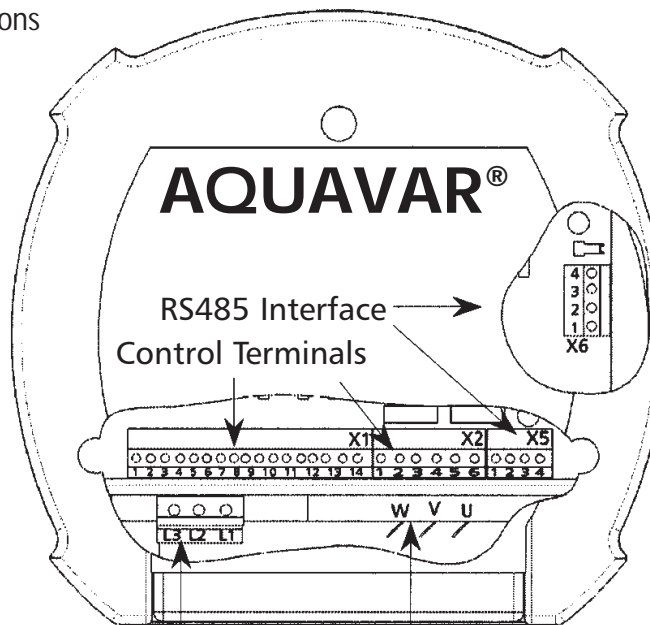

Power Supply
3x400 VAC
L₁, L₂, L₃

Motor Connection
3 Phase Out
U, V, W

Diagram 9

Installation Procedures

Electrical Connections continued

- Route cable through strain relief and connect to the appropriate terminal block. Tighten strain relief.

WARNING

GOULDS PUMPS STRONGLY RECOMMENDS THE USE OF AN INPUT LINE REACTOR TO SAFEGUARD YOUR AQUAVAR FROM DAMAGE CAUSED BY HIGH VOLTAGE SPIKES. THESE LINE REACTORS ARE AVAILABLE FROM YOUR DISTRIBUTOR AND SHOULD BE INSTALLED WHEREVER UNEVEN POWER SUPPLY IS SUSPECTED. DAMAGE FROM HIGH VOLTAGE SPIKES IN SYSTEMS WITHOUT AN INPUT LINE REACTOR MAY NOT BE COVERED UNDER WARRANTY.

- For multi-pump systems: Use a three core shielded cable to connect terminals 1, 2, and 3 on X5 between the AQUAVAR controller units. These are the RS-485 interface connections. (See Diagram 9 and 11). **Note:** either RS485 port can be used.
 - Connect pump one to pump two, two to three, and three to four.

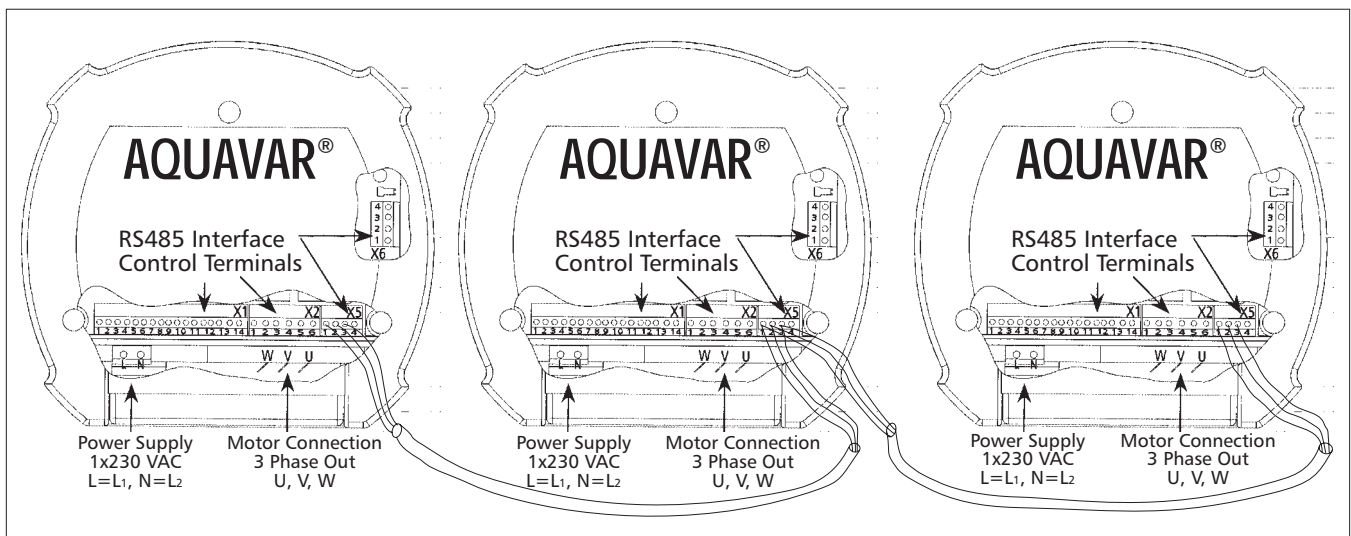

Diagram 10

- External pressure switch or float switch- if used to check incoming pressure and low/no suction. Connect to terminal block X1 at the 6 and 7 location. Refer to Diagram 9. *When using a suction pressure switch, set the cut off at the maximum NPSH required by the pump.*

Note

If an external switch is NOT used, install a jumper wire between X1 Locations 4 and 5.

- External on/off

If used to turn the AQUAVAR controller on or off from an external panel or controller, connect to terminal block X1 at the 4 and 5 location (refer to Diagram 9, page 17).

Installation Procedures

17. Pump running signal and fault signal

Pump running and fault signals such as lights may be wired to the AQUAVAR and set up in remote locations such as central control rooms. The fault signal can be wired to X2 pins 1, 2 and 3 and the pump running signal to X2 pins 4, 5 and 6.

18. Analog output of pressure or frequency

A meter can be connected to X1 pins 10 and 11 for remote display of actual system pressure or motor running frequency. The meter must be 0-10 volt with no more than 2 mA.

19. Second Sensor Input

The ground pin (X1-10) used for analog output can also be used to bridge a connection for a second sensor. This can be digital (on/off) such as a switch which would be connected between X1-10 and X1-14. Another choice is a sensor with a voltage signal of 0-10V or 2-10V which would be connected to X1-10 and X1-13. A final choice is a 4-20 mA current sensor which would be connected to pins X1-10 and X1-12.

20. Replace AQUAVAR controller ground wire to top cover and carefully reinstall top. Carefully position the wires so that the cover sets firmly. Do not force the cover on.

21. With the cover in place, check the operation of the three buttons. You should be able to feel the button actuate. If not, lift the cover and raise the screws (counter-clockwise) on the button. Repeat as necessary. Replace the cover screws.

22. Connect the opposite end of the power cable to a fuse box or a circuit breaker panel.

Note

Power supplies using G.F.I. breakers will cause nuisance tripping which will result in the AQUAVAR controller displaying an "undervoltage" fault.

Pump Priming

Refer to your pump operation manual for instructions on pump priming. You will need to unscrew the pressure transducer and adapter if you used the pump fill plug for mounting. When priming is complete, replace the pressure transducer.

Run Test

WARNING

DO NOT APPLY POWER TO THE AQUAVAR CONTROLLER OR PUMP UNTIL ELECTRICAL CONNECTIONS HAVE BEEN REVIEWED BY A QUALIFIED ELECTRICIAN AND MEET ALL APPLICABLE STATE AND LOCAL REQUIREMENTS.

Installation Procedures

Instructions

1. Check all wiring. (Rotation of motor.)
All motors used with the AQUAVAR controller are three phase. You will need to check the direction of rotation of the motor shaft. If you have followed all of the previous steps carefully, you should now be ready to apply power to the AQUAVAR controller unit. To change rotation of motor, switch any two output leads (U, V, W) on AQUAVAR with power disconnected.

2. Close discharge valve.
Make sure the discharge valve is closed. Apply power to the AQUAVAR controller. The first screen appears for 2 seconds and shows the software version and manufacture date. The next screen will appear automatically
**If auto start is preprogrammed "ON", pump will start immediately.*

3. Check Power Light 

Check the AQUAVAR controller panel. The **"power on"** light should be illuminated and the display should say **"No Autostart - disable inverter."** If either of these conditions is not present, turn off all power to the AQUAVAR controller and recheck all connections.

Screen

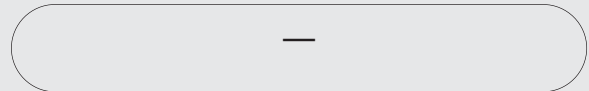

ITT Industries
SW:120

Date: 10/30/00

NO AUTOSTART - DISABLE INVERTER



WARNING!

FAILURE TO DISCONNECT AND LOCKOUT ELECTRICAL POWER AND WAIT FIVE MINUTES FOR CAPACITOR DISCHARGE BEFORE SERVICING AQUAVAR CONTROLLER CAN CAUSE SHOCK, BURNS, OR DEATH.

Note

To change the display language on the AQUAVAR controller, press the "S" key and the up arrow key at the same time. A scrolling line will appear on the bottom of the screen and tell you which button to push for the language you want. After selecting the language, press the up arrow to return to the main display.

4. Check Display.

*** If these conditions exist, proceed.
If NOT, check all wiring.**

5. Press the down arrow key ▼
The next display will be:

Screen

NO AUTOSTART - DISABLED INV.

INVERTER STOP - ON -> START

Installation Procedures

6. Press the up arrow ▲ to turn on the AQUAVAR controller.

RUN LIGHT ON

7. Open the discharge valve slowly until the pump starts. Observe the rotation of the pump shaft or motor fan. If rotation of motor is reversed, disconnect input power on AQUAVAR. Then change any two leads on AQUAVAR output (U, V, W). See Diagram 9, page 18.
8. Close the discharge valve.
9. Press the down arrow ▼ to turn off the AQUAVAR controller. (Inverter Stop - On → Start)
10. If the direction of rotation was correct, proceed to the **Programming** section beginning on the following page.
11. If the direction was not correct, **remove all power from the AQUAVAR controller and wait five minutes.**

Open the AQUAVAR cover and exchange any two of the three motor leads: U, V or W. Close the AQUAVAR. Repeat steps 1 through 5 to check the direction of the motor shaft rotation.

Programming

Programming of the AQUAVAR controller is accomplished by using the three pressure sensitive buttons on the control panel along with the two line LCD display.

The format of the program is a series of menus which can be scrolled through by using the select "✱" button. Each screen display is used to provide information about the operation of the system or to change one or more of the operating parameters.

Changes are made by pushing the up or down arrows.

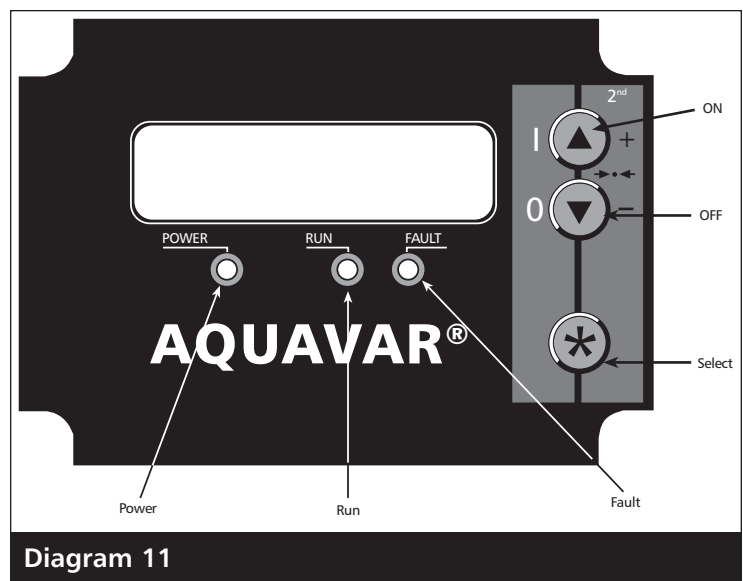

Diagram 11

I. The Main Menu - Setting Single Pump Constant Pressure

Diagram 15 shows the display screens in a flow chart format. Refer to this flow chart for the next 6 steps.

There are ten display screens in the main menu which will allow you to set the required system pressure, save it, and turn the system on. Several of these display screens were already used during the test run. After power has been turned on, the "Power on" light should be illuminated and the display should briefly show the software version and date, then show "No Autostart - disable inverter."

◆ Programming

Instructions

1. Check Power Light 
2. Press the down arrow  to advance the display to:
3. Press Select  to advance the display to:

Screen

NO AUTOSTART - DISABLE INVERTER

INVERTER STOP - ON->START



REQUIRED VALVE - XXX PSI

Note

If "Inverter Locked" is displayed, the external on/off switch is in the off position or contacts at X1:4 and 5 are not jumped.

4. Enter the pressure  you want the pump to maintain (constant pressure) for your system.

Press the  until the reading shows the value you want. Use the down arrow to back up if you have gone too far.

For example: if you need a constant pressure of 50 PSI in your system at various demand rates, you would enter 50 as the value by using the .

5. Autostart setting

Press  to advance the display to:
(This displays the autostart setting.)

Push  to turn the autostart function on.

Screen



50

AUTO START - OFF

AUTO START - ON

If the autostart function is on, the AQUAVAR controller will automatically turn on and resume activity when power is restored after a failure. If autostart is off, the AQUAVAR controller must be manually turned on by the operator after a power failure. Be sure the discharge valve is closed to prevent pump start.

Note

If you have advanced past a window and want to return to it, press  and  at the same time to back up.

Programming

6. Press  to advance the display to:
This display shows the last recorded error or fault encountered by the AQUAVAR controller.

ERROR 1

7. Press  to advance the display to:
This in the error which occurred before the last one.

ERROR 2

8. Press  to advance the display to:
The error before error 2.

ERROR 3

9. Press  to advance the display to:
The error before error 3.

ERROR 4

10. Press  to advance the display to:
The error before error 4.

ERROR 5

11. Press  to advance the display to:
This is the total amount of run time of the motor. It can be reset using a method described later.

TOTAL RUN TIME
0000:00

12. Saving changes

Press  to advance the display to:

SAVE ??? ▲ + ▼

13. Press and hold down **BOTH arrows**  at the same time until the display changes to:
This will allow you to save the changes you have made in the microprocessor memory.

SAVE ??? SAVED

14. After about five seconds the display will automatically return to:

INVERTER STOP - ON->START

Push . The AQUAVAR controller will begin to automatically maintain system pressure at the point you have selected and the display will show the pressure set point.

Note

If the AQUAVAR controller is not maintaining the rating you selected, check the sensor adjustment procedures on page 56 and check your rotation.

Programming

AQUAVAR Controller Program Flow Chart Single Pump Constant Pressure

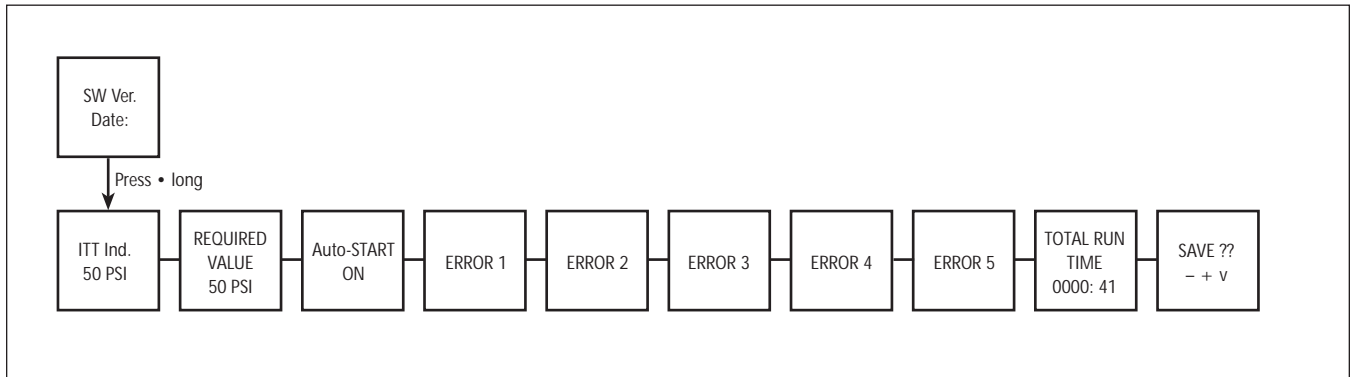

Diagram 12

WARNING

FAILURE TO SAVE SETTINGS AFTER PROGRAMMING RESULTS IN LOSS OF PROGRAM VALUES WHEN POWER IS REMOVED!

II. Single Pump - Pump Protection

The AQUAVAR controller has the ability to protect the pump by shutting it off in low/no suction or run out conditions.

Note

Low/no suction protection can be managed by the installation of a suction line pressure switch, or float switch for a tank. This switch is connected to the AQUAVAR controller as described earlier in the Electrical Installation section. The cut off setting for this switch should be the maximum NPSH required by the pump.

To set run out protection:

For steps 1 through 8, refer to the flow chart, diagram 13.

Instructions

1. Password *The password protection prevents untrained personnel from accidentally changing the base settings.*

- From the main menu, hold down the  key for 2-3 seconds until the display changes to:

Screen

PASSWORD 0000

Programming

2. Press the ▲ key until you reach the number 66. You will now be able to access all of the alternate menus for all AQUAVAR controller optional controls.

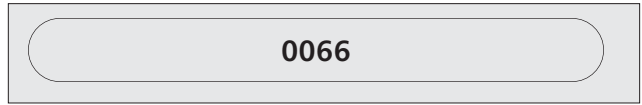

3. Press * to advance the display to the next window:

The jog mode is very useful because it allows you to check on the actual outgoing frequency and system pressure. By pressing either ▲ or ▼ the controller changes to manual, and you can change the frequency to set any constant speed. The AQUAVAR returns to normal automatic operation when you leave the jog mode window.



4. Continue to briefly touch the * key to scroll past all of the windows and submenus until you reach:

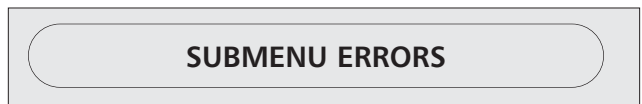

5. Hold the * key down for 2-3 seconds until the display changes to:

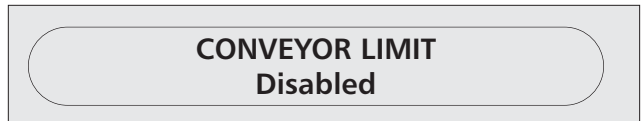

6. Set the minimum pressure the system is allowed to maintain before shutting down. For example, if the set point for the system is 50 PSI, and the operator will allow anything above 41 PSI, then the conveyor limit would be set at 40 PSI. This function can also be turned off by pressing ▼ until "disabled" is shown.

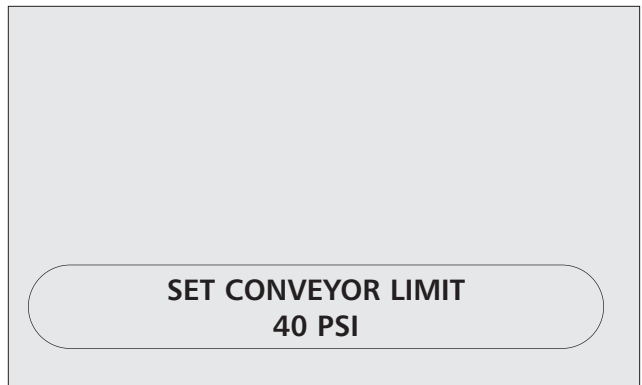

Programming

To set timed protection:

7. **Delay Time** Enter the amount of time that the pump is allowed to run at maximum frequency after pressure begins to drop below the conveyor limit. This should never occur if the system has been properly sized and there are no leaks in the system.

Note: This delay time is also applied to low suction pressure.

DELAY TIME

Press the ▼▲ to enter the number of seconds. The pump will run after pressure begins to drop at pump run out or a suction switch activates.

15 SEC

8. **Error Reset** Turning this control on will enable the AQUAVAR controller to retry its operation five times when a fault condition occurs. Turning the control to "off" means that the AQUAVAR controller will shut down the first time a fault occurs. Select the mode you want by pushing the up or down arrow key.

Note

"Fatal" errors will always shut down the system the first time.

- Press * to advance the display to:

ERROR RESET

Press ▲ to set the time between attempted restarts or ▼ to disable this function

CLEAR ERRORS
0000

9. **Clear error.** The error memory can be deleted by entering a password supplied by your distributor.

Returning to normal operation:

10. Hold down the * key for 2-3 seconds until the display changes to:

Screen

SUBMENU ERRORS

11. Briefly touch the * key to scroll until you reach the display:

SAVE ??? ▲ + ▼

12. Press both ▲▼ at the same time until the display changes to:

SAVE ??? SAVED

After a moment, the screen will automatically return to the main menu start position.

Programming

Entering compensation values: (system curve)

For steps 1 through 4, refer to the flow chart.

Instructions

1. From the main menu, hold down the  key for 2-3 seconds until the display changes to:

- Enter **66** by pressing the 

Screen

PASSWORD 0000



0066

2. **Freq.- Lifting 30.0 hz** *This indicates the speed (flow rate) at which you want the pressure compensation to begin. On a 60 hz system, there is virtually no flow below 40 hz. Set this frequency with the up arrow. On a 50 hz system, the normal starting point would be 30 hz.*

- Use the  key to scroll through the menu screens until you reach:
Change if required.

FREQ - LIFTING 40.0 HZ

3. Use the  key to move to the next screen:



- Use the   to enter the percentage pressure increase **calculated on page 29**.

LIFT - INTENS. 0.0%

LIFT - INTENS. 3.0%

Increase values are recommended from 0 to 20%. If your friction loss increase is above 20% of your set pressure, please contact the AQUAVAR distributor or factory for application assistance. 0-99.9% actual.

4. Save the new settings.

- Use the  key to scroll to the screen
- Press both the  arrows until the display indicates the save process is complete.

SAVE ???  + 

SAVE ??? SAVED

The screen will automatically return to the main menu.

Programming - System Curve Compensation

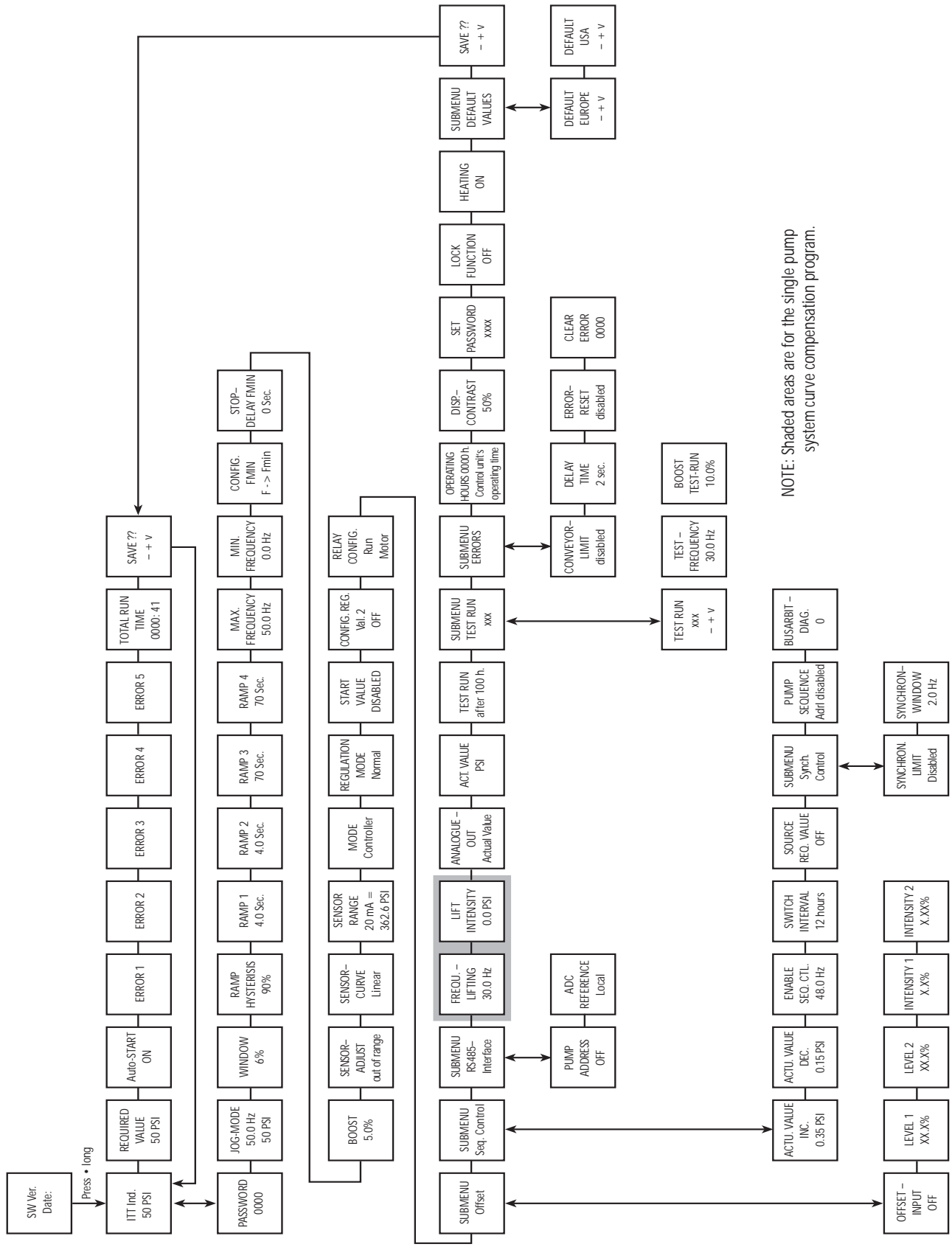

NOTE: Shaded areas are for the single pump system curve compensation program.

Programming

Circulator applications

On circulator pumps, the system curve can be automatically tracked through the use of a differential pressure transducer. This pressure transducer reads the outgoing discharge pressure and the incoming return pressure and compensates for differences in pressure as demand and speed increase. Programming is the same as just covered for the single transducer version. Data on the differential pressure transducer can be found in Appendix A.

IV. Single Pump Constant Flow



A single pump AQUAVAR controller system can also be set to maintain a constant flow by changing motor speed to create more or less pressure when demand changes. The pump should be selected so that the flow rate required is approximately in the middle of the pump curve and the maximum pressure is within the performance of the pump at maximum speed. In general, pumps are not designed to be piped in series (discharge to suction) due to maximum working pressure limitations. Select a single pump which meets system requirements through either higher staging or larger impeller diameters.

An orifice plate with differential transducer or a flow transducer can be used for constant flow applications. Follow the instructions provided with the orifice/transducer or flow transducer assembly for installation procedures and electrical connections.

Instructions

In flow applications, you will want to change the sensor curve from linear or to quadratic and the units from PSI to %, when using to orifice/transducer assembly. To do this, hold down the

 key at the main menu until screen:

1. Enter the number **66**.
2. Briefly press the  key to scroll through the displays until screen:
3. Use the  to change to Quadratic. **Note:** If you are using a flow sensor rather than an orifice plate, leave the sensor curve at linear.
4. Briefly press the  key to scroll through the displays until screen:

Screen

PASSWORD 0000

0066

SENSOR CURVE

QUADRATIC

DIMENSION UNIT PSI

Programming

Single Pump Constant Flow continued

5. Use the ▲ to change the units to GPM if you are using a flow sensor or % if you are using the orifice plate.



6. Hold down the * key until the screen:

7. Hold down the * key until the screen:

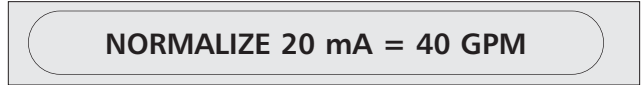

8. Enter either 37 psi for orifice plate application or the maximum flow range of your flow sensor in gpm.

9. Hold down the ◀▶ at the same time until

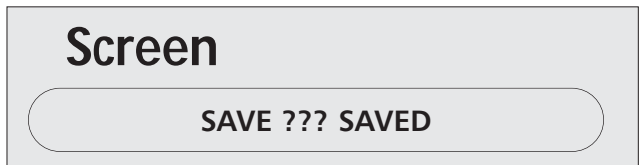

The display will automatically return to the main menu.

10. Advance to the screen:



11. Use either ▲▼ to enter the flow you want to maintain on the AQUAVAR controller (see example). For orifice plate applications, use the table below to set the required %.



Select orifice size from the following chart. Select the orifice by the maximum flow of the pump.

Orifice	Nominal Pipe Size	Flow Range GPM
1	1"	12-35
2	1"	18-52
3	1 1/2"	20-62
4	1 1/2"	32-90
5	2 1/2"	35-105







Orifice	Nominal Pipe Size	Flow Range GPM
6	2 1/2"	52-160
7	3	52-160
8	3	70-210
9	3	120-350

Based on the maximum flow shown for the orifice selected, calculate the percent of maximum flow you want to maintain. For example, to maintain a flow of 20 GPM with a #1 orifice, select 57% ($20 \div 35$).

Programming

V. Single Pump - Level Control Applications

For drainage applications using a surface pump, the transducer is typically needed to measure pressure on the suction line. As the catch basin or tank empties, the pressure will decrease, and the pump needs to slow down and eventually stop. This is the opposite way the AQUAVAR controller would usually respond. To change to suction side measurement:

1. On the main menu, enter the PSI value of the liquid at the LOWEST level you want to maintain. For example, you may want to leave 3-4 feet of water in a tank which is equal to 2-3 PSI.
2. From the main menu, hold down the  key for 2-3 seconds until the screen changes to:
 - Enter 66 by pressing the  key.
3. Use the  key to scroll to:
 - Use the  key to change to inverse.
4. Briefly press the  key until the screen:
5. Hold down the  at the same time until:
The display will automatically return to the main menu.

In operation, the pump will start wherever the suction side pressure is above the set point and slow down and stop when the suction pressure comes down to the set point and stays there.

Screen

REQUIRED VALUE - PSI

PASSWORD 2000

0066

REGULATION MODE - NORMAL

REGULATION MODE - INVERSE

SAVE ??? +

SAVE ??? SAVED

Note

For discharge level control, the programming operation is the same as a constant discharge pressure system.

Programming

VI. Single Pump - Submersible Applications and Minimum Frequency

It is possible to use the wall mounted version of the AQUAVAR controller with a submersible pump.

*Never attempt to mount an AQUAVAR controller on the pump itself in these applications since the AQUAVAR controller is not designed to be submerged. The standard distance allowed between the pump and the AQUAVAR controller is up to 60 feet. If you need a longer connection, be sure to contact your distributor for a drive applied filter.

The submersible pump will often use motor service factor and will overload the AQUAVAR controller at maximum speed. To avoid this, select an AQUAVAR controller based on the full load amp rating of the motor and the maximum amps allowed by the AQUAVAR. If you have questions about the requirements of the submersible pump and which AQUAVAR controller to use, please contact the AQUAVAR controller distributor or factory applications Goulds Pumps.

The submersible pump can be set for either constant pressure or level control applications as described in programming section I and section V. Normally, the constant pressure application would use well pumps or turbines with a steady source of water. Drainage applications would normally use a sump, effluent or sewage pump.

Minimum Frequency

Many submersible well pumps have a required minimum frequency to keep motor bearings lubricated. To avoid running the motor at lower frequencies, you can program in a minimum. For most Franklin submersible motors the minimum is 30 Hz so a setting of 35 Hz is good.

DANGER - BY ELECTROCUTION

End suction centrifugal pumps may also be used in level control systems for draining or filling. Multiple pumps end suction or submersible systems may also be used in level control.





Programming

At the status window, hold the  key until you reach the password screen. Enter the password.

PASSWORD 0066

Use the  key to advance to:



MINIMUM FREQUENCY
0 Hz

Use the  and  to change to the desired minimum frequency (Example 35 Hz).

MINIMUM FREQUENCY
35 Hz

Use the  key to advance to:

CONFIG. FMIN
F -> FMIN

Use the  and  arrow keys to change to:
This allows the AQUAVAR to go down to the selected minimum frequency but not below it.



CONFIG. FMIN
F => 0

Note

In the setting $f \rightarrow F_{min}$, the Aquavar will only run between minimum frequency and maximum frequency. Automatic shut off is not possible, but manual shut off is possible with external on/off connected at X1/4 and X1/5.

Use the  key to advance to:

STOP - DELAY FMIN
OS

Use the  and  keys to enter the number of seconds the AQUAVAR will run at minimum speed before it shuts off when there is no demand.

STOP - DELAY FMIN
10

Advance to the same window and save all settings.

SAVE ???  + 

Programming

VII. Setting A Second Fixed Required Value

The AQUAVAR controller can also be used in applications where the required value changes. As an example, a single pump system might be used to supply both water supply and irrigation needs on a farm. When the irrigation system is used, the pressure which needs to be maintained is higher than the pressure for normal water supply. The AQUAVAR gives you the ability to program in this higher set point and to automatically change to it when the irrigation system turns on, and change back when it turns off.

Electrical

Wiring for the switch to change between one set point and the other is shown below. This could be a normal switch or a timer for automatic operation. Wire the switch to X1-14 and X1-10 (ground). When the switch is open, set point 1 is used. Closing the switch activates set point 2.

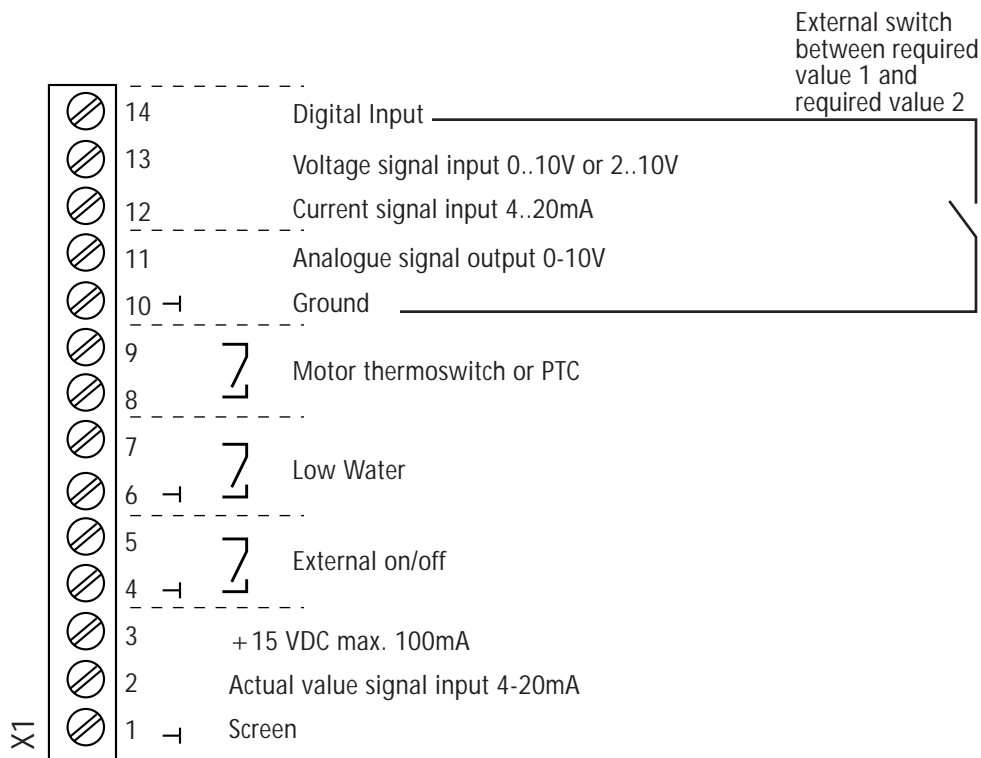

*Refer to Appendix B for explanation of terminals.

Programming

Enter the submenu by holding the  key.

ITT INDUSTRIES
20 PSI

Enter the password and press the  key.

PASSWORD
0066

Press the  key until you see the screen:

CONFIG. 2ND REQUIRED VALUE
OFF

Use the  and  arrows to change the selection to:

CONFIG. 2ND REQUIRED VALUE
INT

Note

The other possibilities (Ext. ADC-1, Ext ADC-U 0-10V, Ext ADC-V 2-10V) involve variable second values controlled by a second sensor. These are discussed in the next section.

Advance the display with the  key to:

SUBMENU
SEQUENCE CONTROL

Hold the  key to enter the submenu.

Press the  key to advance to:

SOURCE REQUIRED VALUE
OFF

Use the arrow keys to change to:

SOURCE REQUIRED VALUE
ADR1

Hold the  key to leave the submenu then advance to:

SAVE ??? +

Press both buttons until the display changes to:

SAVE ??? SAVED

Press the  key to advance to:

REQUIRED VALUE 1
XXX PSI

Use the  and  arrows to set the first required value.

Close the switch connected to X1-10 and X1-14 to activate the second set point. The display changes to:

INT REQUIRED VALUE 2 XXX PSI

Use the  and  arrows to set the second required value.

Advance to the Save window and save all settings.

SAVE ??? SAVED

Two required values are now stored in memory. The active required value is determined by the switch on X1/10 - X1/14. As noted earlier, this can be a manual or automatic (timer controlled) switch.

Programming

VIII. Variable Second Required Value

In this section, we will cover the set up and programming of the AQUAVAR for a second sensor input. This sensor can be either a 4-20mA or 0/2-10V device such as a pressure transducer, flow transducer, heat sensor, etc. When connected to the AQUAVAR, the output of this second sensor becomes the new set point. As input from the second sensor changes, the set point will also change.

Example: If the second sensor was a 150 psi 4-20mA pressure transducer and the input to the AQUAVAR was 10mA, the set point would become 62 psi. If the input dropped to 8mA, the set point would go to 94 psi. Keep in mind that this change only offsets the set point. Motor speed continues to be varied by the primary transducer reading of demand change. This function could be used for chlorine or fertilizer injection where a flow sensor in the main pipe would track system demand and adjust the pump flow set point to keep the mix percentage the same.

Electrical

Connect the second sensor as shown to X1/10 and either X1/12 for 4-20mA or X1/13 for 0/2-10V.

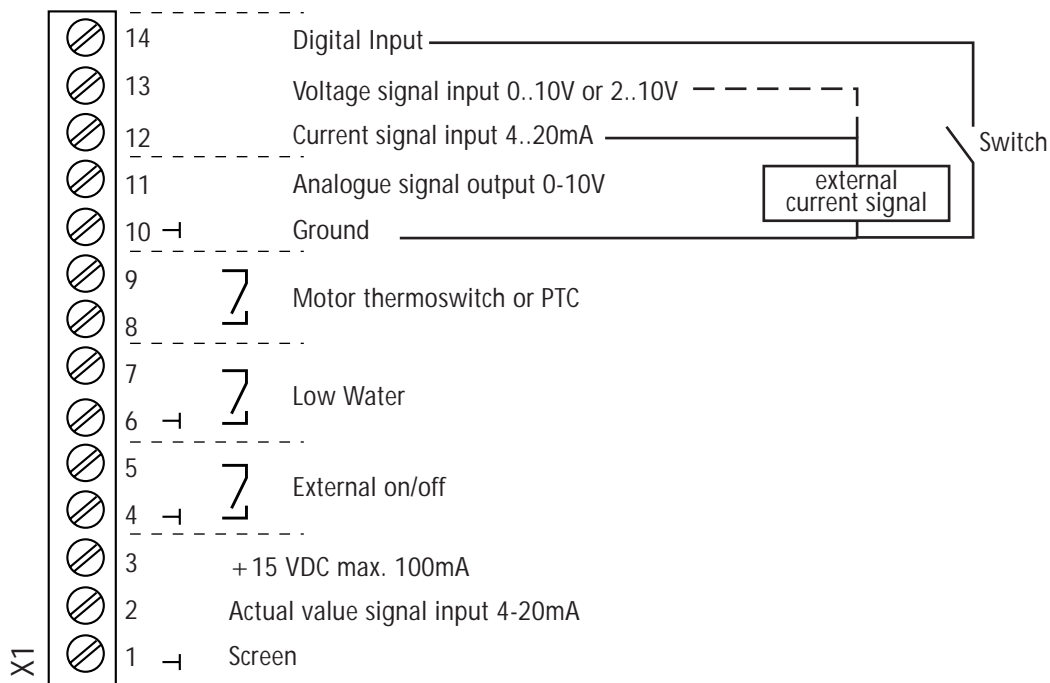

Programming

Enter the submenu by holding the  key.



ITT INDUSTRIES
20 PSI

Enter the password and press the  key.

PASSWORD
0066

Press the  key until you see the screen:

CONFIG. 2ND REQUIRED VALUE
OFF

Use the  and  arrows to change the selection to:
EXT ADC-1 for 4-20mA input
EXT ADC-U 0-10V for 0-10V input
EXT ADC-U 2-10V for 2-10V input

CONFIG. 2ND REQUIRED VALUE
EXT ADC-1

Advance the display with the  key to:

SUBMENU
SEQUENCE CONTROL

Hold the  key to advance to:

SOURCE REQUIRED VALUE
OFF

Use the arrow keys to change to:

SOURCE REQUIRED VALUE
ADR1

Hold the  key to leave the submenu then advance to:



SAVE ??? +

Press both buttons until the display change to:

SAVE ??? SAVED

Press the  key to advance to:

REQUIRED VALUE 1
XXX PSI

Use the  and  arrows to set the first required value.

Close the switch connected to X1/10 and X1/14 to activate the second set point. The display changes to:

REQUIRED VALUE 2
EXT ADC-1 XXX PSI

Note

This display is now a read only window. The actual set point is coming from the external signal.

Offsets

It is also possible to use second sensor input as an offset for the primary required value. An example would be locating the second sensor in a supply tank or well and setting an offset so that when the water level got too low, the pump discharge pressure setting would be reduced until the tank or well had recovered.

Another example would be the use of both a pressure sensor and flow sensor in the discharge line so that if the flow became too high for the pump, the offset could reduce the discharge pressure set point to keep the pump from cavitation.

Programming

To implement the offset function,

Enter the submenu by holding the  key.



Enter the password and press the  key.



Press the  key until you see the screen:



Enter the submenu by holding down the  key.



Use the  and  arrows to select the source of the second value:



- EXT ADC-1 for 4-20mA input
- EXT ADC-U 0-10V 0-10V input
- EXT ADC-U 2-10V 2-10V input

Refer to the following page to determine the offset variables and intensities to use for your application.

Example for Offset:

Sensor range: 20mA \triangleq 150 PSI

Required value: 75 PSI

Level 1: 20% of the 2nd additional input **Level 2:** 80% of the 2nd additional input

Intensity 1: -10% \triangleq -15 PSI (refer to the required value)

Intensity 2: -20% \triangleq -30 PSI (refer to the required value)

Programming

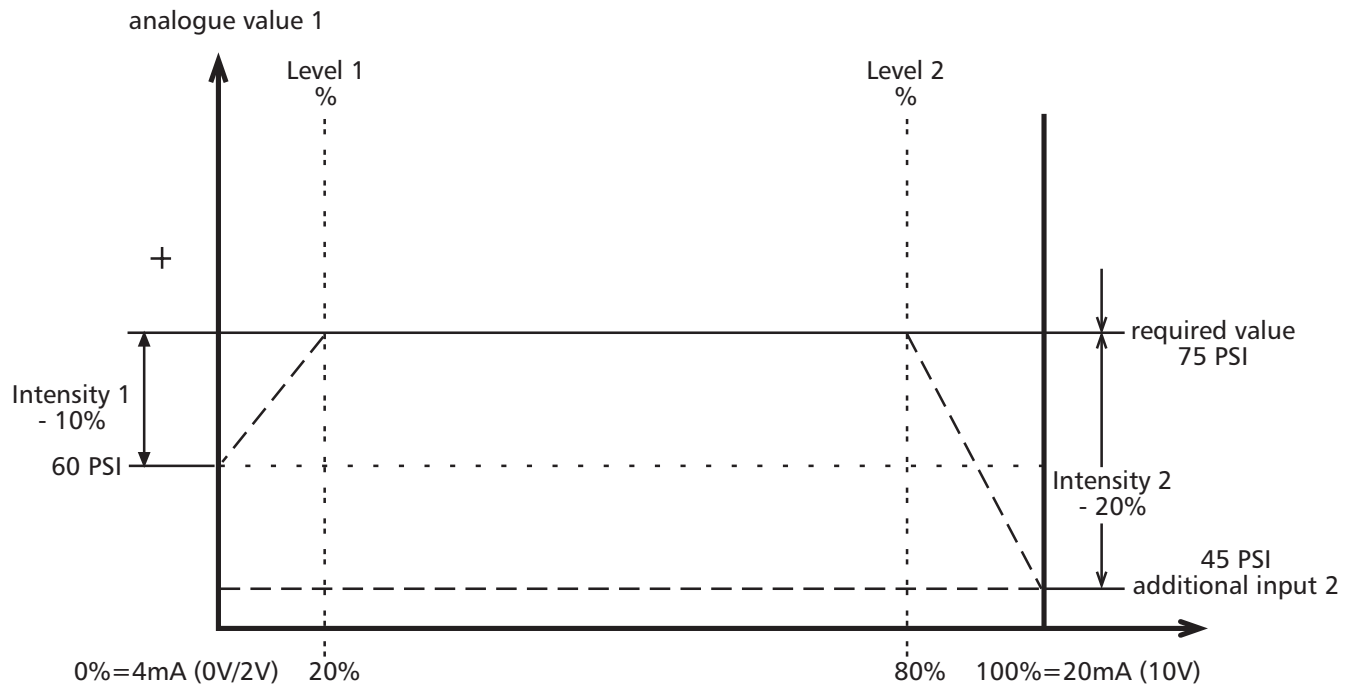

At *Level 1* and *Level 2*, you enter the required value in percent from the *Second Additional* input (20%) and (80%).

Intensity one and two depend on the *Sensor range* of the external value signal. The *Intensity 1* that you have entered is valid until you reach *Level 1*, after reaching *Level 1* the *Required Value* has no offset.

The *Required Value* is valid until you reach *Level 2*. After reaching *Level 2*, the new value, depending on the *Intensity 2*, is valid.

Note that for most applications only one level and one intensity would be needed.

Press the  key to advance to:

LEVEL 1
XX.X%

Use the ▲ and ▼ arrow keys to enter the % of the additional input range where the first offset to the required value will occur. The chart on the previous page uses 20% as an example.

LEVEL 1
20.0%

Press the  key to advance to:

LEVEL 2
XX.X%



Use the ▲ and ▼ arrow keys to enter the % of the additional input range where the second offset to the required value will occur (if needed) The chart on the previous page uses 80% as an example.

LEVEL 2
80.0%

Programming

Press  key to advance to:

INTENSITY 1
+XX.X%



Use the  and  arrow keys to enter the % of the required value you want to increase or decrease when the second sensor input is below Level 1. The

INTENSITY 1
-10.0%

chart on the previous page uses -10% as an example. This represents an application where the second sensor is in a well or tank. When the pressure reading or the second sensor drops below an acceptable minimum, the discharge pressure set point automatically drops by 10% to give the tank or well time to recover. As soon as the pressure in the well reaches the minimum again, the set point returns to normal.

Press the  key to advance to:

INTENSITY 2
+XX.X%

Use the  and  arrow keys to enter the % of required value you want to increase or decrease when the second sensor input is above level 2. The

INTENSITY 2
-20.0%

chart on the previous page was -20% as an example. This represents an application where the second sensor is a flow transducer in the discharge line. When the flow reading on this second sensor goes higher than an acceptable maximum, the discharge pressure set point automatically drops by 20% until flow demand is reduced. As soon as flow is back below the maximum again, the set point returns to normal.

Hold the  key to get out of the submenu.

SUBMENU
OFFSET

Press the  key to advance to:

SAVE ??? +

Press both arrows to save the settings.

SAVE ??? SAVED

IX. Multiple Pump Constant Pressure - Slave Pump

In applications where a second pump is required only for peak demand at limited times, a second variable frequency drive is not needed. In such a situation, the AQUAVAR can start and stop a second pump at full speed when it is needed for peak demand.

This method would not be desirable if the second pump is required frequently since the energy saving and lead/lag capability with a second AQUAVAR is not available with this method. A description of a multi-pump system with more than one AQUAVAR is described in section X.

Programming

Electrical Connection

Dry contacts are available to connect a relay at X2/4-X2/5 (normally closed) or X2/6-X2/5 (normally open). The relay is located between main line power and the second, full speed, pump. **NOTE:** 250 VAC, 1 amp is maximum for the above contacts.

In this method, the second (slave) full speed pump may be either single or three phase with any motor enclosure. The main pump (AQUAVAR controlled) must still be a three phase motor and TEFC if the AQUAVAR is to be pump mounted. Note that if a three phase slave pump is used, a starter must still be provided.

Programming

At the status window, hold the  key to advance to:

ITT INDUSTRIES
50 PSI

Enter the password and press the  key until you reach the display.

PASSWORD
0066

Use the  and  keys to change the setting to:

RELAY CONFIG.
RUN SIGNALING

Press the  key to advance to:



RELAY CONFIG.
SIMPLE MULTI-CONTR.

Hold the  key to enter the submenu.

SEQUENCE
SUBMENU CONTROL

Use the  key to advance to:

ACT. VALUE INC.
0 PSI

Use the  and  keys to set the frequency of the main (AQUAVAR controlled pump) that you want to reach before the slave pump is started. This would normally be at or near full speed (example 58 Hz).



ENABLE SEQUENCE CONTROL
50 HZ

Press the  key to advance to:

ENABLE SEQUENCE CONTROL
58 HZ

Hold the  key to enter the submenu.

SUBMENU SYNCH.
CONTROL

Use the  and  keys to set the slowest speed you want the main (AQUAVAR controlled) pump to work before turning off the slave pump. In 60 Hz systems, little pumping is done below 40 Hz, so this would be a good setting.

SYNCHRON. LIMIT
DISABLED

SYNCHRON. LIMIT
DISABLED

Programming

Hold the  key to return to the synchronous control submenu.

SUBMENU
SYNCH. CONTROL

Hold the  key again to return to the sequence control submenu.

SUBMENU
SEQUENCE CONTROL

Press the  key to advance to:

SAVE ??? +

Hold the  and  arrows until:

SAVE ??? SAVED

Using the above settings, when there is system demand, the AQUAVAR pump will start first and maintain pressure until it reaches 58 Hz. At that point, the relay will start the slave pump at full speed. As soon as the slave pump is started the AQUAVAR pump will reduce its speed and continue to vary to maintain constant pressure. If demand is reduced and the AQUAVAR controlled pump slows to 40 Hz, the slave pump will be turned off. At this point, the AQUAVAR controlled pump would increase speed to continue to maintain constant pressure.

Note

When using the slave pump, this pump will start and go to full speed immediately. You must use your common values and mechanical devices to prevent "run out" or over pressure of this system or "hunting" or oscillation of pressure will occur.





Programming

X. Multiple Pump Constant Pressure and System Curve Compensation

When two, three, or four AQUAVAR controller controlled pumps are connected in a system, they can be programmed to work together to maintain system pressure up to the maximum flow rate of all pumps combined. As the first pump reaches its maximum speed and flow, the second pump will automatically turn on (and so on). In addition, the sequence of the pump that will run first (lead pump) can be automatically varied to reduce premature wear on any one pump in the system.

1. Refer to the section **The Main Menu - Setting One Pump Constant Pressure**. Follow steps 1 through 6, then continue with step 2 below.

Instructions

2. From the main menu, hold down on the  key for 2-3 seconds until the display changes to:
 - Use  to enter the number:
3. **Mode: Multicontroller** *This setting allows the AQUAVAR controller units to communicate with each other in a multi-pump system.*
 - Use the  key to scroll through the screens to reach:
 - Use the   to change the setting to:

Screen

PASSWORD 0000

0066

MODE CONTROLLER

MODE: MULTICONTROLLER

Note

Other possibilities are Synchronous Controller described later in this section and Actuator which shuts off the internal controller and allows the AQUAVAR to function as a standard VFD. This can be from external input (actuator) or manual control (actuator local). This is described further in operator custom features and displays.

4. Advance to the next screen:

SUBMENU SEQ CONTROL

Programming

Multiple Pump Constant Pressure... continued

Generally, a slight pressure drop is allowed on the first pump before the next is started. This allows for brief system fluctuations without pump cycling. Once the next pump starts, however, you will want the system to resume its normal set pressure.

5. To do this, enter the amount of pressure drop you will allow before the next pump starts.

Diagram 19 shows the pressure drop and increase.

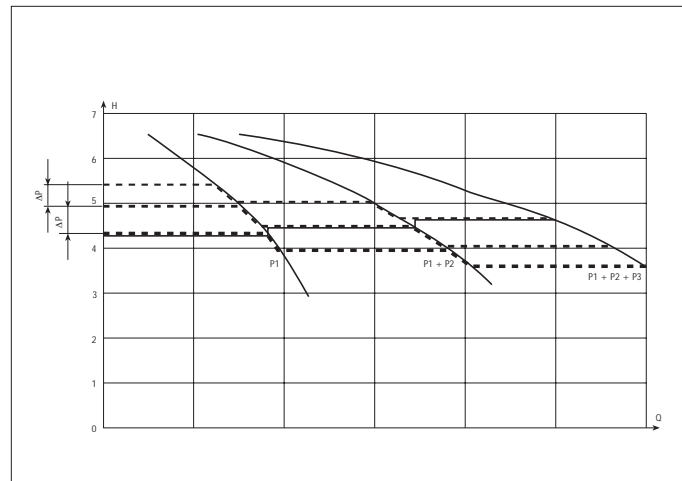

Diagram 16

6. To increase the pressure even more to compensate for system losses at higher flow, enter the total of the system drop allowed before next pump starts and the increased pressure desired.

For example, if the pressure drop allowed is 5 PSI before the next pumps starts, and the increased pressure needed to compensate for system losses is 3 PSI, you would enter 5 + 3, or 8 PSI to compensate for both system pressure drop and compensation requirements.

*Examples: Value Increase = Value Decrease → Pressure is constant
Value Increase > Value Decrease → Pressure increases with each additional pump
Value Increase < Value Decrease → Pressure decreases with each additional pump*

Note

This value is cumulative. An extra 3 PSI will be added to the total system pressure with each additional pump which turns on. For example, if the initial system pressure was 50 PSI, pump two would create 53 PSI, pump three would create 56 PSI, and pump four would create 59 PSI system pressure.

7. Pressure Incr. 000 psi *This setting tells the AQUAVAR controller how much to increase the pressure setting when the second pump turns on.*

- Hold down the  for 2-3 seconds until the display changes to:

ACTUAL VALUE INC. 000 PSI

Programming

Multiple Pump Constant Pressure... continued

8. Enter the value required.

- Press  to advance to the next screen:
- Enter the **PSI drop** before the next pump starts. Use this value for each pump in the AQUAVAR controller system.

Screen

ACTUAL VALUE INC. 0003 PSI

ACTUAL VALUE DEC. 000 PSI

ACTUAL VALUE DEC. 0002 PSI

9. Enable Seq. Ctl. 60.0 hz *This tells the next pump when the preceding pump has reached its maximum speed.*

- Press  to advance to the next screen:

Screen

ENABLE SEQ. CTL. 60.0 HZ.

In most North American applications, this would be set for 58-60 hz. If you are using a 50 hz system, reset the display for 50 hz.



Note

The next pump will not start until both the system pressure drop and maximum first pump speed have been reached. If Enable Sequence Control is set higher than the maximum frequency, the next pump will not start.

10. **Switch Interval** *This allows you to set the amount of time before the "lead pump" switches over to another pump in the system. This means that the first pump to turn on when the system starts up will change when the switch interval time is reached. A manual change over is also possible by using the  in the first main menu display.*

- Press  to advance to the next screen:

SWITCH INTERVAL

- Use the   to set the time desired.
(If set over 100 hours, the function is disabled.)

Programming

Multiple Pump Constant Pressure... continued

Source Required Value

The next screen refers to the use of a second input signal for changing the required value. This was discussed in Section VIII.

If a second sensor or switch is used, you must tell the AQUAVAR which pump has the connection. Use the ▲ and ▼ keys to select. ADR1, ADR2, ADR3 or ADR4. If you are not using a second sensor, leave this set to "off".

SOURCE REQUIRED VALUE
ADR1

Follow the other steps in Section VIII for using a second sensor with multiple pumps.

11. Synchronous Control: If you choose synchronous control, the second pump (and 3 or 4) will all try to regulate the pressure together by running at the same frequency (speed). In order to get the second pump to shut off, you need to set a minimum frequency.

- To choose synchronous control hold * to enter the submenu.
- When synchronous limit appears use ▲ to set the frequency for pump #2 to shut off. For 60 Hz pumps, this would normally be 50 hz.
- If pumps 3 and 4 are used, advance to the synchronous window with *
- The window can be set between 0-10 Hz. This number will be added to the synchronous limit. For example, if the synchronous window is set at 5 hz, pump four will turn off when all pumps go below 50 hz, and pump three will turn off when all pumps go below 45 hz.

SUBMENU SYNCH. CONTROL

SYNCHRON LIMIT - DISABLED

SYNCHRON LIMIT - 50 HZ

SYNCHRON WINDOW - 0 HZ

SYNCHRON WINDOW - 5 HZ

Note

The synchronous option can only be used if all pumps are the same.

Programming

Multiple Pump Constant Pressure... continued



12. Pump Address *In this section you will give the pump an address number. Generally, the first pump programmed will be number 1, the second will be number 2, and so on. The purpose of this is to help the AQUAVAR controller sequence the start and stop activity of the pumps in the system including the selection of lead and lag pumps.*

- Hold the  for 2 seconds to return to:

SUBMENU SEQ. CONTROL

- Press  again briefly to advance to:

SUBMENU RS485 INTERFACE

- Press  again for 2 seconds to display:
- Use the  to select the address number. (1, 2, 3 or 4)

PUMP ADDRESS OFF

Screen

13. Hold the  for 2 seconds to return to:

SUBMENU RS485 INTERFACE

- Press  briefly to advance to:

FREQ. LIFTING

- Press  again to advance to:



LIFT INTENSITY 0%

- Set at 0% with 

SAVE ??? +

- Hold the  for 2 seconds to return to the Main Menu.

- At the Main Menu, advance to the screen:

SAVE ??? +

- Press  at the same time until the display changes to:

SAVE ??? SAVED

14. Repeat steps 1 through 12 for each pump in the system. Use a different address number for each pump.

Programming- Multiple Pump Constant Pressure

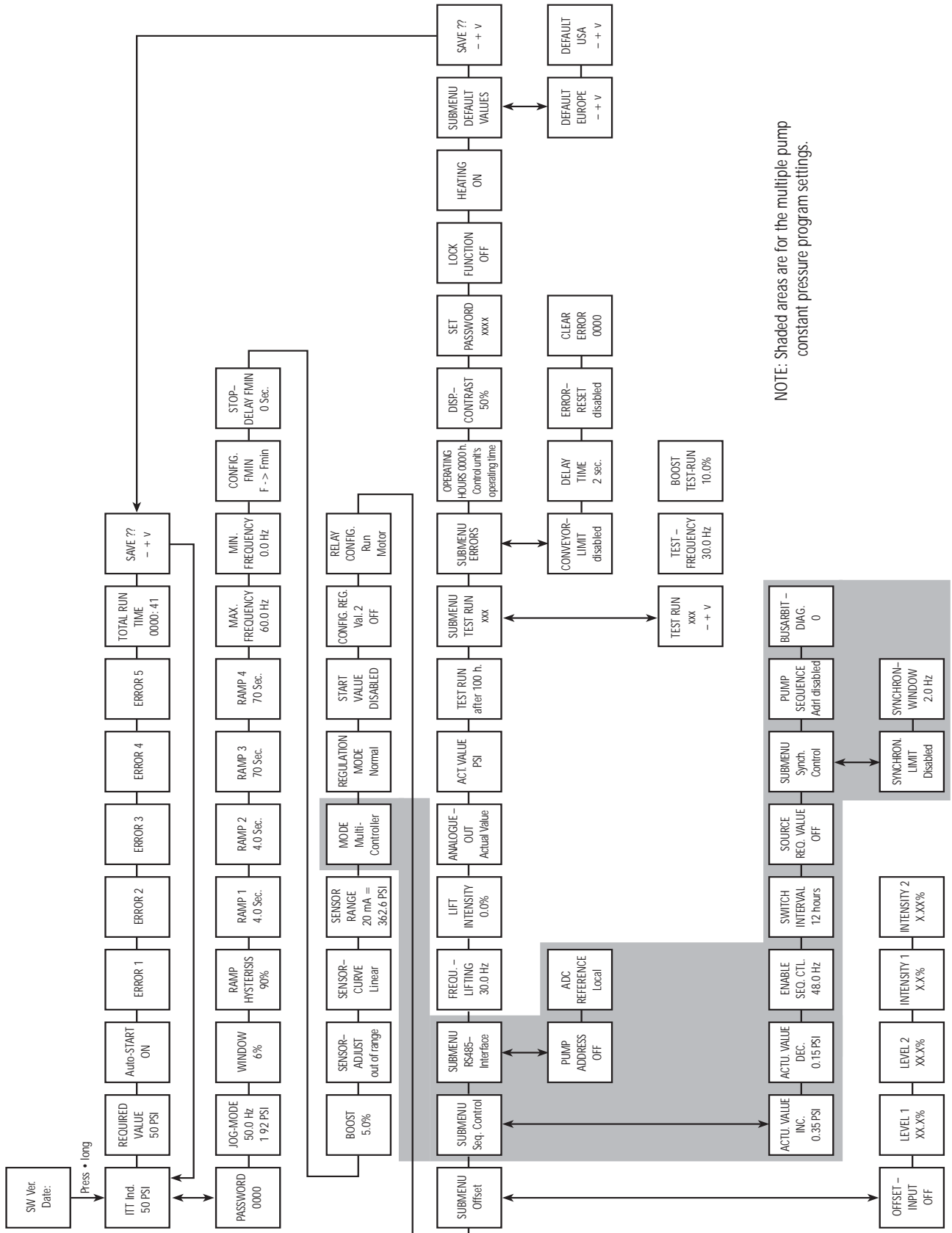

Programming

XI. Multiple Pump - Pump Protection

The AQUAVAR controller can protect the pump by shutting it off in low/no suction or run out conditions.



Note



Low/no suction protection depends on the installation of a suction line pressure switch or float switch for a tank. This switch is connected to the AQUAVAR controller as described earlier in the electrical installation section. The cut out setting for a suction pressure switch should be greater than the maximum NPSH required by the pump.

To set low/no flow and run out protection:

Instructions

1. Press the  key for 2 seconds and advance to the:

- Use  to enter **66**.
- Use the  key to scroll to:

*Conveyor limit is default "disabled".
Use  and  to set a low discharge pressure shut off value.

2. Press the  key for 2 seconds to display: Set the minimum pressure the system is allowed to maintain before shutting down. For example, if the set point for the system is 60 PSI and the operator will allow anything above 55 PSI, then the conveyor limit would be set at 54 PSI.

- Press  again briefly to advance to:
- Enter the amount of time the pump is allowed to run after the suction pressure switch or float switch has activated. This is also used to set the amount of time the pump can run at maximum frequency after the pressure drops below the conveyor limit.

Screen

PASSWORD 0000

0066

SUBMENU ERRORS

CONVEYOR LIMIT - 40 PSI

DELAY TIME
0.0 SEC

DELAY TIME
2.0 SEC

Note



When using this feature, each pump in the system can have its own switch or a junction box must be used for multiple pump operation with one switch.

Programming

Multiple Pump Protection... continued

Instructions

3. **Error Reset** *Turning this control on will enable the AQUAVAR controller to retry its operation five times when a fault condition occurs. Turning the control to "off" means that the AQUAVAR controller will shut down the first time a fault occurs.*

- Press  to advance the display to:
- Use the   to select the mode you want.

Screen

ERROR RESET

Note

"Fatal" errors will always shut down the system the first time.

Returning to normal operation:

4. Hold down the  key for 2-3 seconds until the display changes to:

SUBMENU ERRORS

- Scroll past the next few screens (briefly touch the  key) until you reach:

SAVE ???  + 

5. Save the new settings by pressing the  at the same time until the display changes to:

SAVE ??? SAVED

After a moment, the screen will automatically return to the main menu start position.

6. *Repeat steps 1 through 5 above for each of the other pumps in the system which have suction switches or float switches.*

Operator Custom Features and Displays

Operator Custom Features and Displays

Refer to the overall Program Flow Chart for the location of the following operator custom features.

To access a particular feature:

- Enter the password (66) at the Main Menu.
- Scroll to the selected feature by using the “*” key.
Other features have already been discussed in the application set-up instructions described earlier.

Note

Custom features are pre-programmed to default settings. These settings are the same for all horsepower sizes and may require adjustments to meet the particular pump system and horsepower requirements.

Jog-Mode

This display shows the actual frequency the pump is running at and the signal being read by the pump’s transducer. The frequency (speed) can also be manually changed by using the up or down arrow keys. When leaving the Jog Mode, the pump will automatically return to normal operating speed unless you have set 0.0 for the frequency setting (this sets the AQUAVAR controller to “off”).

Window

The AQUAVAR controller regulates motor speed in very small increments, allowing the pressure to rise and fall within a range around the set point. This range is called the “window.” The size of this window can be set as a percentage of the set pressure.

For example, if the set pressure is 100 PSI and the window is set at 10%, the swing in pressure would be 10 PSI (5 PSI above the set pressure and 5 PSI below the set pressure) during operation. This large a swing would probably become noticeable as motor cycling or surging. This setting should be adjusted according to the required value. Lower required values should use about 10% and higher required values should use about 5%.

Ramp Hysteresis

This setting tells the AQUAVAR controller what portion of the operating window should be set aside for electrical fluctuations in the system (Hysteresis). Part of this built-in inaccuracy is due to the pressure transducer and part is due to the inverter drive. Typically, this would be set at 50%. In a 4 PSI window, 2 PSI would be the expected hysteresis error. This is also the point at which the AQUAVAR changes over to the long slow ramps.

Ramp Settings

The next four displays relate to the time it takes for the AQUAVAR controller to speed up and slow down the motor when pressure or flow requirements change. **In normal operation, these should not be changed. Please carefully read the descriptions for the ramp speeds.**

Operator Custom Features and Displays

Ramp 1

This ramp is the fast run up time used when the pump first comes on and is trying to reach the set point. The normal set point for this ramp is 4 seconds for the horse power range 2 through 15 hp. For versions with higher horsepowers, 20 hp and above, the setting should be 10 seconds minimum. A setting which is too fast may overload the inverter. A setting which is too slow tends to cause uneven outgoing pressure (pressure drops).

Ramp 2

This ramp is the fast run down time used when the pump is shutting down after demand has ended. The normal set point for this ramp is 4 seconds for the horse power range 2 through 15 hp. For versions with higher horsepowers, 20 hp and above, the setting should be 10 seconds minimum. A setting which is too fast leads to pump oscillation or hunting. A setting which is too slow tends to generate overpressure. **Note: air in the pump system can cause a condition which looks like hunting. Please be sure all air is purged from the system before trying to change ramp 2.**

Ramp 3

This ramp is the slow run up time used when the pump is operating within its set point window as described above. The normal setting is 50 seconds. A setting which is too slow may cause the outgoing pressure to drop when demand varies. A setting which is too fast may lead to over oscillation and inverter overload.

Ramp 4

This ramp is the slow run down time used when the pump is operating within its set point window. The normal setting is 50 seconds. A setting which is too slow leads to oscillation. A setting which is too fast delays motor shut down after demand is over.

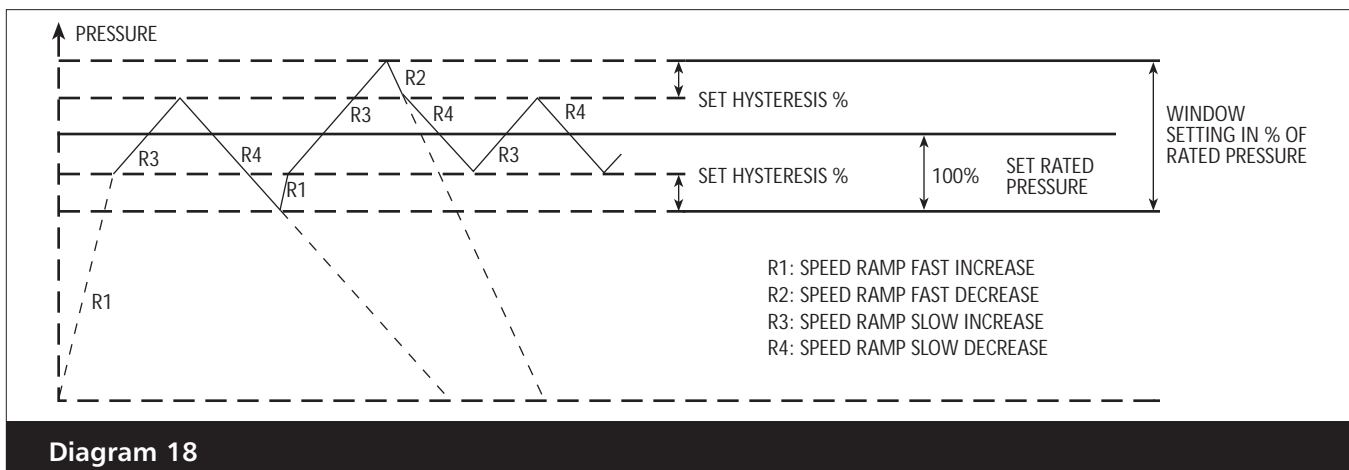

Diagram 18

Maximum Frequency

This setting should match the requirements of the motor being used. If the motor being used is a 60 hz motor, the setting should be 60 hz. If the motor is 50 hz, change this setting to 50 hz.

Note

It is possible to set this frequency up to 70 hz. This is not recommended for standard pumps. A 10% increase in frequency causes 33% more power draw.

Operator Custom Features and Displays

Minimum Frequency

Settings between 0 and 50 Hz are possible. When a minimum frequency is set, the AQUAVAR will not run the pump below this speed. See the section on submersible pumps.

Config. F Min

This setting allows you to configure a minimum frequency in one of two ways. If you select "f->0", the inverter will go down to the minimum frequency and then continue running at that level for the delay time (see next features). If there is no demand, the inverter will shut off. It will not ramp down through lower frequencies.

If the selection is "f->f min" the inverter will slow to the minimum frequency but will not stop unless there is a fault or an external control is connected to terminals X1/4 and X1/5. **Caution: There is a possibility of pump overheating without automatic shut off.**

Stop-Delay F Min

This is the delay time in use if "F->0" is set above. This is set in seconds and will hold the minimum frequency according to this time delay.

Boost

This setting boosts outgoing voltage to the motor to compensate for the difference between frequency and voltage as speed changes. **This should be set at 5%. Do not change this under normal operating conditions to avoid overloading the motor. Adjust to 10% maximum for high starting torque applications (i.e. submersibles, turbine or cast iron pumps).**

Sensor Adjustment

The AQUAVAR controller can automatically calibrate the sensor (transducer or flow meter). Close all gate valves around the sensor, turn off the pump, and relieve static pressure so that the sensor reads zero pressure or flow. Press the up and down arrows at the same time until "**adjusted**" is displayed.

Note

If "Out of Range" is displayed, the system is still under pressure and the transducer cannot be calibrated.

The second sensor adjustment, "**Sensor Curve**," allows control of linear and quadratic sensors. Use the linear setting for pressure, differential pressure, level, temperature and flow transmitters. Use the quadratic setting only for constant flow control with orifice plates and differential pressure transmitters.

The third sensor adjustment, "**Normalize**," allows the maximum pressure or flow rating to be set for the sensor being used. Refer to the specification sheet for the sensor you are using to determine the maximum rating at 20mA. Use the up or down arrow to advance to the correct setting. The standard transducer supplied with the AQUAVAR controller is 25 bar (360 PSI).

Mode

This setting is used to tell the AQUAVAR controller the type of input which will be used to control the system.

Operator Custom Features and Displays

Controller - Used for a single AQUAVAR controlled pump

Multicontroller - Used where several AQUAVAR pumps are connected via RS485

Synchronous Controller - Used for multipump systems where all pumps will run at the same frequency.

Actuator - Used if you have an external (PID) controller. In this mode the internal controller is turned off. The output frequency changes proportionally based on sensor input (X1/2) and the following chart. Low water, thermal protection and external on/off continue to function.

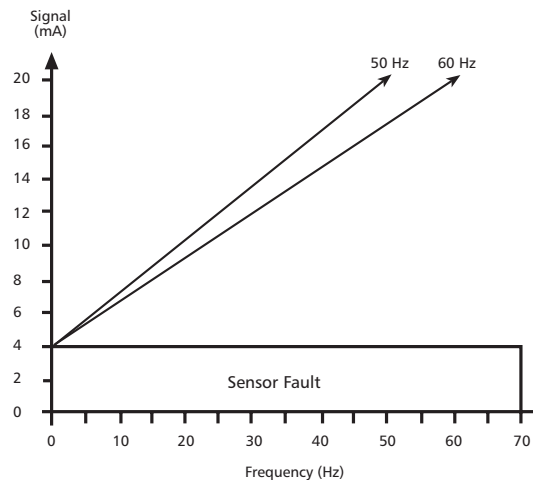

Manual - When this is used, the required value window in the main menu will change to “manual control” and the actual frequency and actual value will be displayed (similar to the Jog Mode). The ▲ and ▼ keys can then be used to set a specific frequency. If saved, this will become the set point after power loss.

Start Value

This allows you to set a percentage of the required value at which the AQUAVAR will begin to ramp up when there is demand. For example, if the required value is 50 psi and the start value is set at 45 PSI, the AQUAVAR will start when system pressure drops to 45 psi.

Config. Required Value 2

This allows you to select the types of second input value in use in a two value system. Refer to Section VII.

Relay Config.

This is used to select the function of the output relay for either motor running or slave pump. See Section IX.

Submenu Offset

A discussion of the various windows and functions of this submenu can be found in Section VIII.

Operator Custom Features and Displays

Regulation Mode

The "**Normal**" setting increases the output speed with falling signal (constant pressure in discharge). The "**Inverse**" setting decreases the output speed with falling signals (suction control).

Submenu Sequence Control - *for further information see Section V*

Use this menu to allow starting and stopping of up to 4 pumps with the RS-485 communication port. The following setup items allow the user to determine when the pumps will start and stop.

Actual Value Increase

Enter a value to increase the setpoint (required value) after a lag pump starts. Initiates a pressure boost, when the second pump starts. Pressure loss compensation for multi-pump.

Actual Value Decrease

Enter a value to decrease the setpoint (required value) after a lag pump starts. The required value will be calculated from the following equation after a lag pump starts:

$$\text{NEW REQUIRED VALUE} = \text{REQUIRED VALUE} - \text{ACT. VALUE DEC.} + \text{ACT. VALUE INC.}$$

This setting will allow a system pressure drop, before starting second pump in multi-pump systems. For no modification to the setpoint keep both of the increase and decrease values at the same value.

Actual value decrease pressure setting and maximum frequency of pump must be achieved before second pump will start in a multi-pump system.

Enable Sequence Control

Enter the maximum speed prior to starting the lag pump(s). Typically set a +2 HZ below the maximum frequency. To disable pump staging set this value greater than the maximum frequency. This should be set for your maximum frequency of each pump or below.

Switch Interval

Enter the amount of time the lead pump should operate prior to alternating the pump sequence. This variable allows equal wear on all controlled pumps. Set this value greater than 100 hours to deactivate alternation.

Source Required Value

Used to set the address for the source of a second required value. May be set to off, ADR1, ADR2, ADR3 or ADR4. Default is off.

Submenu Synchronous Control

To use this method of multiple pump control, all pumps must be exactly the same. When the synchronous control is active all of the activated pumps work together to satisfy the required value. When the synchronous control is deactivated the lead pump(s) run at full speed while the lag pump modulates in speed to satisfy the required value.

Operator Custom Features and Displays

Synchronous Limit

To deactivate synchronous control, set this value below 0 HZ. This will be the lowest speed that multiple pumps will operate prior to switching off the last pump in sequence. For 60 Hz systems using synchronous mode, this would normally be set to 40 Hz. This window is also used for the stop value of a slave pump.

Synchronous Window

This is a frequency offset that increases the synchronous limit that each lag pump is stopped at. This allows the minimum speed to be increased for each lag pump. For example, if the synchronous limit were set for 40 Hz and the synchronous window is set for 50 Hz. Pump 3 shuts off at 45 Hz and pump 2 shuts off at 40 Hz.

Pump Sequence

This screen is located in the Sequence Control Submenu and displays the address and status of the pump as follows:

AdrX *	Pump address 1-4 is displayed as assigned by the operator during system set up. If the * is displayed, this is the address for this pump.
hold Px	The pump is off and the pressure/flow regulator is working.
run Px	The pump is running and the pressure/flow regulator is working.
stop Px	The pump is stopped and the pressure/flow regulator for this pump is blocked.
disabled	The AQUAVAR controller is not ready to start (Autostart on the main menu is off).
error	There is a fault in the AQUAVAR controller operation. This will be identified in the error displays (see pages 67-68).
fault	There is a problem with communication to other pumps via the RS-485 connection.
detected	Communication with other pumps via the RS-485 connection is enabled.

Bus

The Data Bus Diagnostic display is a warning which shows the number of attempts used by the RS-485 interface to synchronize the pump controllers in the system. In a multiple pump system, each AQUAVAR controller must be set to the same operating parameters. If this is not the case, or if there is some mechanical or electrical block to the signal, the display will indicate a fault. To clear the display, unplug the AQUAVAR controller for about one minute.

Pump - Address

If only one unit is used the proper setting is "OFF". If 2 through 4 units are installed, each pump must be assigned a unique address number. Used in multi-pump programming to address each AQUAVAR.

Operator Custom Features and Displays

ADC Reference

This setting tells the unit where to look for the actual value signal. Set to "LOCAL" if the actual value is obtained from a 4-20mA transmitter wired to the unit's actual value input terminals (X1: 2, 3). Set to "REMOTE" if the actual value is obtained from the RS-485 port via a remote device. Default is local.

Frequency Lifting

Allows modification of the required pressure to accommodate for system frictional losses due to increased flow. Enter the speed at which system losses are a concern and compensation should begin to be added to the required pressure. Typical settings are 40 HZ for a 60 HZ motor and 30 HZ for a 50 HZ motor. See section III for more information. System curve compensation for one pump at a certain frequency.

Lift Intensity

Enter a value for increasing the required pressure due to frictional losses once the frequency lifting speed is exceeded. Calculate the pressure drop due to frictional losses and divide by the required pressure and input this value as a percentage. Enter 0% if frictional losses are of no concern. Increases the output pressure in PSI (used for one pump systems).

Reference

This display is located in the RS-485 Submenu and shows whether control is being received from the local ADC (Analog/Digital Converter) or from another source shown as "*SIO*" via the RS-485 interface.

Analog Out

It is possible for the AQUAVAR controller to supply an output signal from 0-10 Volts at a maximum of 2 mA. Connection of the outside recording device (such as a meter) is done at terminals 10 (ground) and 11 (output signal) of terminal strip X1 inside the AQUAVAR controller drive head. The "*Analog Out*" display allows you to select either frequency or pressure as the output to be displayed. 0-10 Volts equals 0-100% in either frequency or pressure.

Pressure Units

This display allows the user to select Bar, PSI, or meters of water for pressure or gallons per minute for flow, or percent. If percent is selected, the percentage displayed will be the percentage of the maximum sensor value. Default is PSI.

Operator Custom Features and Displays

Test Run

The AQUAVAR controller can carry out a test run of the pump either automatically or manually. For automatic settings, enter the number of hours you want to elapse between the last pump shut down and the test. Possible settings are between 10 and 100 hours. When the time has elapsed, the pump will automatically turn on at 50% of maximum frequency (normally 30 hz) for 20 seconds and then turn off again.

Note

This will only work when the Auto Start function on the main menu is on. If you do not want to use the automatic test run function, you can turn it off by selecting 100 hours, and then pressing the up and down arrows at the same time until the display changes to deactivated.

Submenu Test Run Manual

To conduct a manual test run of the pump, enter this submenu by holding down on the **S** key. The first display in the submenu is the activation display for the test run. To start the test, press the up and down arrow keys at the same time. If you want the test to be conducted at some other frequency than 30 hz, use the next display in the submenu: **Test Frequency**. This can be set from 6-60 hz. The final display in this submenu is **Boost Test-Run**. This allows you to set a starting voltage boost to ensure proper starting of the motor at the frequency you have selected. This should be left at the pre-set 5% setting to avoid motor overload. When finished, hold down on the **S** button until the display returns to the **Submenu** display.

Submenu Errors

Two of the functions in this submenu have been covered: **Conveyor Limit** (used to set system shut off when maximum flow is exceeded) and **Delay Time** (used to set pump shut off in conjunction with conveyor limit and a suction side pressure switch or float). The remaining displays in this submenu are used to show the cause of failure in the last three instances where a pump or system failure caused the AQUAVAR controller to turn the pump off.

Within the **Error Submenu**, the **Error Reset** display allows the operator to tell the AQUAVAR controller to re-try pumping after a non-fatal fault. When turned on, the AQUAVAR controller will retry up to five times before shutting the unit off. If Error Reset is off, the AQUAVAR controller will shut down the system the first time a fault occurs. In both cases, the AQUAVAR controller can be reset by removing all power to the unit for at least one minute. This will reset the fault counter to zero.

Clear Errors

This display allows you to clear all error memory by entering a password. To clear error memory, enter 0726, then press "✱" in the clear errors screen once. "Cleared" should appear.

Operator Custom Features and Displays

Operating Hours

This counter displays the total amount of time that the AQUAVAR controller drive head has operated, (whether the pump was running or not). This time can be reset to zero by pressing the up and down arrows at the same time for 25 seconds.

Total Run Time

This display shows the total run time of the pump motor in hours and minutes. This display resets automatically when Operating Hours is reset.

Display Contrast

This display allows the operator to set the contrast of the LCD display on the control panel from 10% to 100%. Use the up and down arrows to set the contrast desired.

Set Password

The pre-set factory password is 0066. This display allows you to create a new password for security. If you decide to change the password, **write it down and store it in a safe place.**

NOTE

YOUR GOULDS DISTRIBUTOR OR APPLICATION ENGINEER WILL NOT BE ABLE TO HELP YOU WITH PROGRAMMING PROBLEMS IF YOU HAVE CHANGED THE PASSWORD AND LOST IT!

Lock Function

This allows the operator to lock all of the settings on the main menu except On/Off. When the lock function is off, main menu settings may be changed normally. On pre-packaged systems, the lock function will assure that package settings remain as selected at the factory. Default is off. Set to "On" to lock out persons from changing settings.

Heating On

In order to prevent the possibility of condensation inside the AQUAVAR controller head, a heating unit (10 watt) is switched on when the pump motor is off. This heating unit can be set for on or off.

Default Values

Default values can be set for either US or Europe base data. The US default is PSI, 60 Hz, etc. To return all settings to the pre-programmed factory settings: press the up and down arrow keys at the same time and hold them as a count down timer counts back from 5 to 0. When complete, the display will return to the main menu and show Inverter - Stop/Default. All settings can be entered again following the directions given in the Programming Section. After loading default values, the screen will flash until values are saved.

Save ??

This display allows any program changes to be saved and return to the main menu. **Remember that all program changes will be cancelled when the system is turned off unless these are saved.**

Repair of Faults and Errors

Repair of Faults and Errors

WARNING



DISCONNECT POWER FROM THE AQUAVAR CONTROLLER BEFORE CONNECTING THE FAULTS TO AVOID POTENTIAL FOR AUTOMATIC PUMP RESTART.

Lack of Water

This error message will be displayed when a switch has indicated that the incoming water pressure or water level in a suction tank falls below the required NPSH of the pump. If suction conditions appear to be correct, check the pressure switch or float switch to make sure it is operating properly. When the suction conditions have returned to normal, the pump will restart automatically. This message will also appear if terminals 6 and 7 on terminal block X1 are not bridged.

Conveyor Control (Value Range Control Error)

The drive is not able to obtain the minimum required value set in the conveyor limit setting. Look for potential reasons for the low signal or lower the "CONVEYOR CONTROL" or increase the "DELAY TIME" settings. Under "SUBMENU ERRORS", check the PSI setting on the conveyor limit and increase the "DELAY TIME".

Overtemp Motor

The motor temperature is too high and has tripped the temperature sensor inside the conduit box. To correct, check terminal connections for evidence of a switch or jumper, check ambient temperature, check rotation cooling (TEFC fan operation), and possible motor overload. Once corrected, the unit may be reset by turning off the AQUAVAR controller for at least 30 seconds.

Overtemp Inverter

The inverter temperature is too high. This is normally caused by a lack of cooling of the aluminum heat sink on the bottom of the AQUAVAR controller. Check this area for dirt, check the flow of air from the motor fan, and check the ambient temperature. Once the temperature has been reduced to the operating range, the AQUAVAR controller can be reset by turning it off for at least 30 seconds.

Over Voltage

The AQUAVAR controller can run at 230 V single phase $\pm 15\%$ or 460 V three phase $\pm 10\%$ in normal U.S. configuration. Voltage spikes beyond this range can cause the unit to shut down. High voltage switching somewhere in the main line can cause such a spike to occur. If this tripping continues, a main line reactor may be installed at the circuit box. A fast setting for Ramp 2 can also cause this error. To reset the AQUAVAR controller, turn it off for at least 30 seconds.

Under Voltage

Check the actual voltage or check for a burned-out fuse or tripped circuit breaker. After correcting the problem, turn off the AQUAVAR controller for at least 30 seconds to reset.

Repair of Faults and Errors

Overloaded

The most common problem is incorrect program settings causing the pump to exceed its duty range. When this happens, the AQUAVAR controller will shut down the system to protect the pump and motor. Check programming, maximum system requirements, pump blockage due to solids, broken mechanical seal, defective non-return valve, pump motor run in reverse, motor amps, and pump selection. A "Limit" message may also appear before "overloaded" which may indicate the pump was running beyond rated capacity. A fast setting for Ramp 1 can also cause this error. Once corrected, the system can be reset by turning it off for at least 30 seconds.

Earth Fault (Short Circuit)

This is a ground fault or short in the electrical system. Possible causes include frayed or faulty wiring and possible moisture inside the AQUAVAR controller cover. Disconnect the unit from the main power supply and check the wiring and for possible moisture. When corrected, turn the unit back on.

Pressure Sensor Error

The pressure or flow sensor is out of order, not connected properly, not zeroed properly, or the cable is damaged. Check the sensor and zero object and then turn the unit back on.

Error 1 through Error 8

These are program errors within the AQUAVAR controller control system. If one of these errors occurs, turn the unit off for at least 30 seconds and then back on. If the error is displayed again, contact your Goulds Pumps AQUAVAR distributor with an exact description of the fault.

Error 1 Eprom Error

Error 2 Security Software Protection Error

Error 4 Keyboard Error, check pushbuttons for proper actuation, or buttons may be held down by the cover being on too tight.

Error 5 Eprom Error

Error 6 Watchdog Error

Error 7 Processor Pulse Error (Failure of oscillator for processor)

Error 8 Invalid Processor Command Error, power wires and motor leads may be too close to the control board or communication ribbon. Use separate conduits for power and control wires.

Inverter Locked

The contacts on X1, terminal strip, 4 and 5, must be open. A jumper wire should be used to close contacts 4 and 5.

? Help Windows

Help Windows

You can access a help display at any time by pressing and holding the “*” and ▲ arrow keys at the same time. This will change the second line of the window to a “running” text which provides more information about the window function. The following list shows the normal window text and the available help text.

Window text	Help Text
No Autostart / ITT Industries Disable Inverter / X.XX PSI	Spanish > Inc.; English > Dec; French > Select
Required Value x.xx PSI	Input Required Pressure / Flow for Value #1 or Value #2
Auto-Start Off	ON = Autostart enabled; Off = Autostart disabled
Error 1	Last Error
Error 2	4th recorded error
Error 3	3rd recorded error
Error 4	2nd recorded error
Error 5	1st recorded error
Total Run Time 0000:00	Total motor run time hh:mm
Save ??? Inc + Dec	Press ▲ + ▼ to save parameter values
Password 0000	Enter Password, Default 0066
Jog Mode 0.0Hz xx.xx PSI	Jog Mode: frequency controlled by ▲ or ▼

Help Windows

Window text	Help Text
Window 4%	Pressure window
Ramp Hysteresis 50%	Hysteresis
Ramp 1 4.0 Sec	Ramp 1: fast acceleration time
Ramp 2 4.0 Sec.	Ramp 2: fast deceleration time
Ramp 3 50%	Ramp 3: slow acceleration time
Ramp 4 50%	Ramp 4: slow deceleration time
Max. Frequency 60.0 Hz	Maximum output frequency range: 6 - 60 Hz
Min. Frequency 0.0 Hz	Minimum output frequency (range: 0 - max. frequency)
Config. FMin f->0	Configuration behavior at minimum frequency
Stop-Delay Time 0 Sec.	Delay for pump stop when f->0 is chosen
Boost 5.0%	Boost, voltage boost applied on start-up and shutdown.
Sensor Adjust? Out of Range	Sensor zero adjustment (press ▲ + ▼)
Sensor Curve	Sensor characteristic curve
Sensor Range 20mA = 25.0 bar (362.6 PSI)	Normalize to max. Sensor Value
Mode: Controller	Mode: controller > pressure control; Actuator > frequency set point as ADC Value Multicontroller > control of up to 4 pumps

Help Windows

Window text	Help Text
Regulation Mode	Pumping regulation mode, normal or increased
Start Value %, PSI	Start value Allows system pressure drop before unit starts.
Config. 2nd Required Value Off	Configuration of a second value
Relay Configuration Run Motor	Relay configuration
Submenu Offset	Submenu offset: to enter push select for at least 1 second.
Offset Input Off	Selection of offset input
Level 1 XX.X %	Start level for offset 1
Level 2 XX.X%	Start level for offset 2
Intensity 1 XX.X%	Intensity of offset 1
Intensity 2 XX.X%	Intensity of offset 2
Submenu Seq. Control	Submenu seq. control; to enter push select at least one second
Pressure Incr. 4 PSI	Pressure increment at switching of additional pump
Pressure dec. 4 PSI	Pressure decrement for consecutive pumps
Enable seq. ctl. 40.0 hz	Frequency limit enable sequence control
Switch interval 12h	Time interval pump sequence change, alternate time.

Help Windows

Window text	Help Text
Submenu Synch. control	Submenu: synchronous regulation; to enter push select at least one second.
Synchron limit 35.0 Hz	Frequency limit to enable the synchronous regulation
Synchron window 5.0 hz	Frequency offset for the frequency limit which activates the synchronous regulation
Pump sequence Adr 1 Hold P1	Diagnostics: Pump sequence and status
BUSARBIT DIAG 0	Diagnostics: Bus arbitration (this pump)
SUBMENU RS485 Interface	Submenu: Serial Interface; to enter push select at least one second.
Pump Address off	SIO address of the pump
ADC Reference local	Pressure or frequency reference enabled by local ADC or by SIO
Frequency Lifting 30.0 hz	Frequency limit for pressure lift
Lift Intensity 0.0%	Max. lift in % of pressure set point at max. frequency
Analog out actual value	Meter output: frequency; pressure
Dimension unit PSI	Displayed dimension unit
Test run after 24 h	Time interval for test run 10 - 100 hr. or deactivated (inc+ dec)
Submenu Test Run Man.	Submenu pump test manual; to enter push select at least one second

Help Windows

Window text	Help Text
Test Run Man. (Inc + Dec)	Start test run with Increase + Decrease
Test Frequency 30.0 hz	Test frequency
Boost Test Run 5%	Test boost
Submenu Error	Submenu: errors; to enter push select at least one second
Conveyor Limit	Value at which pump system shall be deactivated
Delay 2 sec	Enter a time the pump is allowed to run after a suction line sensor has activated, or conveyor limit has been reached.
Error Reset On	Automatic error reset
Clear Errors 0000	Clear error history
Operating Hours xxxxh	Total AQUAVAR controller operating time (reset counters: press inc + dec)
Disp. Contrast 100%	Display contrast
Set Password 0000	Modify password, 0066 Default
Lock function off	On > keypad locked: off > changes allowed
Heating	Internal heating element on/off
Submenu Default Values	Submenu load default parameters to enter push select at least 1 second.
Default USA/Europe Inc + dec	Reset to default parameters
Save ??? Inc + dec	Press Inc + Dec to save entered values

Appendix A

Pressure Transducer Data

Series 1200 Gems Type

Specifications

Measuring Range (FS):	.52 bar	10 bar	25 bar	(other ranges upon request)
Over-Pressure (P _{MAX}):	2 bar	40 bar	100 bar	
Class of protection:	IP 65 (Nema 4)			

Type

Output-Signal:

Supply:

Linearity:

Stability:

Total Error:

Operating Temperature:

Material: Body and diaphragm: 17-4 PH

Sealed gauge:

4-20mA; 2 wire

7-35 VDC

0.5% FS

0.2% FS max.

2% FS

-22°F to 260° F

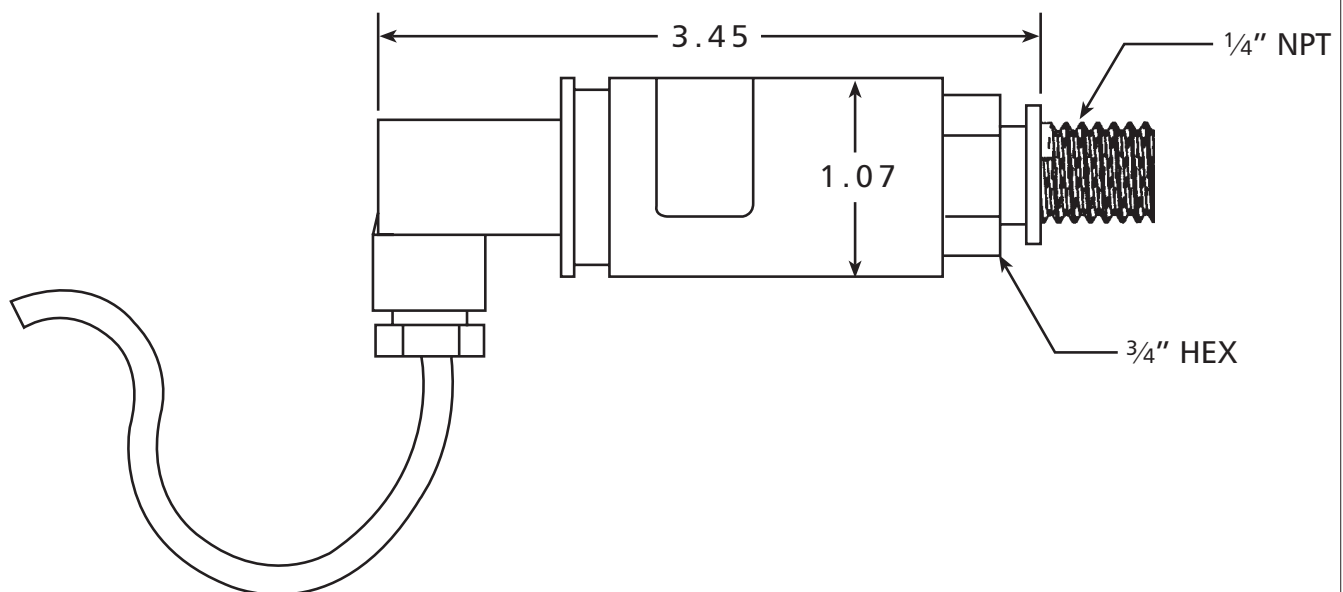

Diagram 20

Appendix A

Differential Pressure Transmitter

Series PD-39S

The sensors of this differential transmitter are two piezoresistive silicon pressure sensors, mounted on a tape (TAP), freely floating in an oil chamber. The pressure is transferred to the sensor by a separating steel diaphragm in the oil chamber.

Plug: mPm 193
incl. 2 m cable

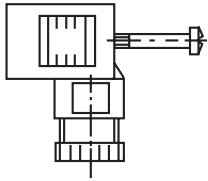

Cable:
Out (white)
+ Vcc (brown)
Screen

Screw joint and cover:

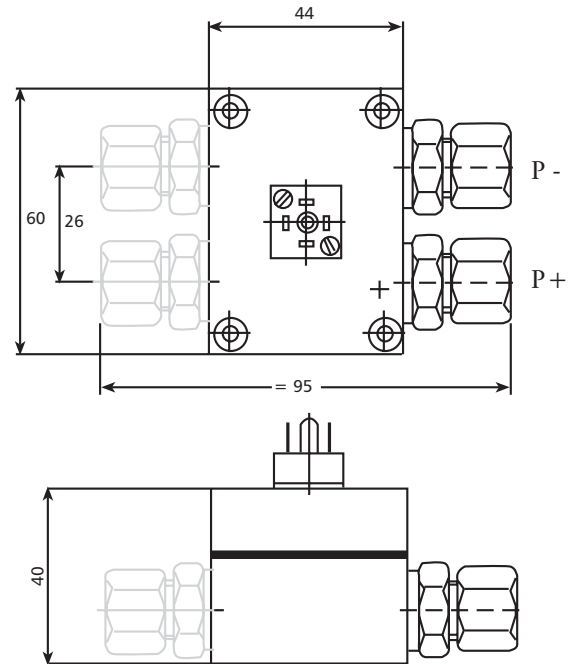

Diagram 21

Specifications

Measuring Range (FS):	0,4 bar	4 bar	10 bar	<i>Differential</i> (other ranges upon request)
Over-Pressure (P _{MAX}):	16 bar	16 bar	16 bar	Single-sided
Class of protection:	IP 65	IP 65		

Type

Output-Signal:
Supply:
Load resistance:

Sealed gauge:

4-20mA; 2 wire
8-28 VDC
max. 50Ω at supply voltage = 10VDC

Linearity:
Stability:

± 0.2% FS; max ±0.5% FS
± 0.1% FS; max ± 0.2% FS

Operating Temperature:
Storage Temperature:

-20° to +80° C
-40° to +120° C

Material: Body and diaphragm: 1.4435 stainless steel

Appendix A

Pressure Transducer Data

Model Delta 692 Differential Pressure Transducer and Orifice Plate

Specifications	Standard 80096 ND
Range (FS)"	2, 5 bar - 37 PSI
Over Pressure (P _{MAX})	12 bar - 177 PSI
Signal over Range	4... 20mA; 2 wire
Power Supply	9... 33 volts DC
E1 Connection	DIN-plug 43650

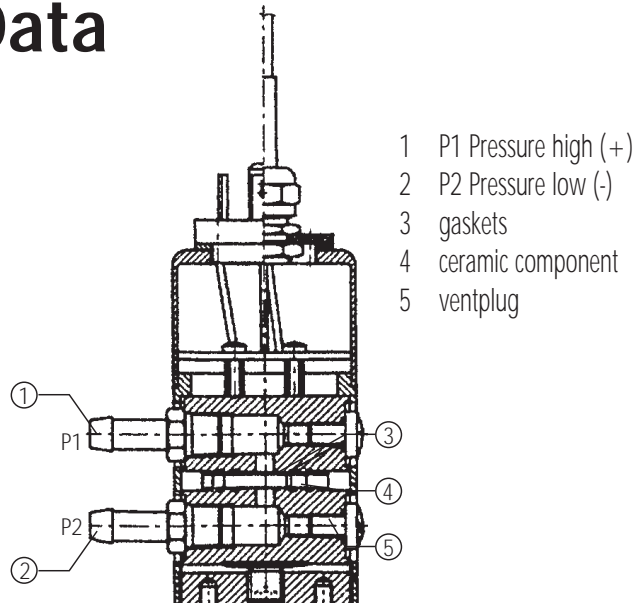

Diagram 22

Hydraulic connection	R 1/8"
Linearity	tip ± .25%FS; max. ± .5%FS
Stability	tip ± .1%FS; max. ± .5%FS
Operating Temperature	-15° - 80° C
Storage Temperature	-15° - 80° C
Materials	Stainless steel (body) Ceramic (diaphragm)

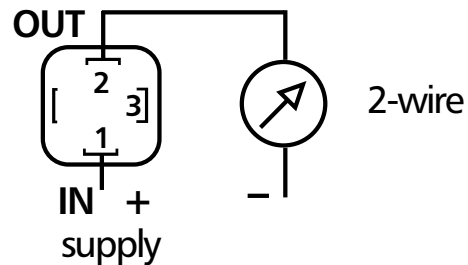

Diagram 23

Nominal Pipe/ Discharge Size	Constant Flow Range
1"	12-35 GPM
1"	18-52 GPM
1 1/2"	20-62 GPM
1 1/2"	32-90 GPM
2 1/2"	35-105 GPM
2 1/2"	52-160 GPM
3"	52-160 GPM
3"	70-210 GPM
3"	120-350 GPM

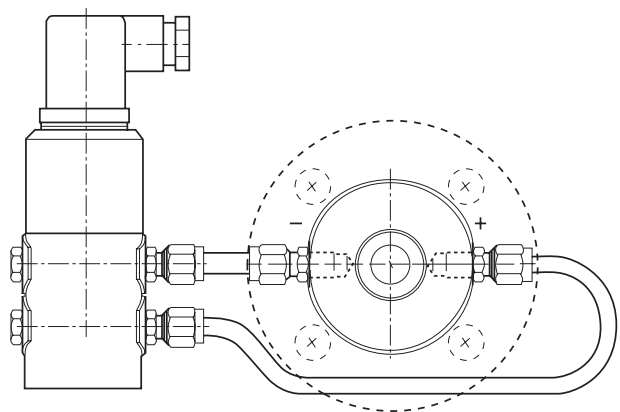

Diagram 24

Appendix B

AQUAVAR Controller Drive Head Technical Data and Terminals

Instructions: Use this supplement for installation and wiring of AQUAVAR models 04168321, 04168331, 04168371, 04168491, 04168501 and 04168511.

AQUAVAR Controller Technical Data:

AQUAVAR Controller		Motor		Supply Voltage 40-60 Hz	Recommended Circuit Protection *
Type	Rated Output	Voltage	Current		
04168321	2 HP	3 ph 230V	7 A	Single Phase 240 VAC \pm 10%	15 Amps
04168331	3 HP	3 ph 230V	10 A	Single Phase 240 VAC \pm 10%	15 Amps
04168371	5 HP	3 ph 460V	9 A	Three Phase 380-460 VAC \pm 15%	15 Amps
04168491	7½ HP	3 ph 460V	13½ A	Three Phase 380-460 VAC \pm 15%	20 Amps
04168501	10 HP	3 ph 460V	17 A	Three Phase 380-460 VAC \pm 15%	25 Amps
04168511	15 HP	3 ph 460V	23 A	Three Phase 380-460 VAC \pm 15%	35 Amps

*Note: Recommend using delay type fused protection. Always refer to NEC and local codes.

Maximum current:

There is a dynamic limit of 500 pulses for current which exceeds maximum allowable. If current remains above the maximum after 500 pulses, the AQUAVAR controller will shut down. After correcting the current problem, the unit may be reset by disconnecting the power supply for over 30 seconds.

Output voltage: Single phase units: three phase 230 VAC
Three phase units: three phase 460 VAC

Output frequency: Operator selectable up to 60 hz
Min. = 0; Max. = 60 hz

Electrical Efficiency > 95%

Protection Against: Short circuit, ground fault, under-voltage, electronics overheating/overload, overvoltage, motor over temperature, standard electronic low/no water (or with external switch), radio emission per EMV, ENV, and FCC

Note

Minimum temperature can be increased to 125°F by using a higher power rating AQUAVAR controller.

Ambient Temp.: 5° - 40° C; (41° - 105° F) - Consult factory for maximum applications with temperatures greater than 105° F.

Storage Temp.: -25° - 55° C

Humidity: 90° F at 105° F, non-condensing. **Condensation not allowed.**

Appendix B

AQUAVAR Controller Drive Head Technical Data and Terminals continued

Air Pollution:	Minor amounts of dust and dirt are permitted. Excessive dust, acids, corrosives and salts must be avoided.																
Altitude:	3300' above sea level, without derating. Derate 2% each 1000' above 3300'.																
Approvals:	UL, CUL, CE																
Enclosure:	NEMA 4, IP 54																
Control:	Modified PID using two point control based on pressure, differential pressure or flow input from electronic sensors.																
Lead/Lag:	Controlled by on-board microprocessor with alternation based on time, and auto start/stop of each pump based on demand.																
Inverter:	The inverter is controlled by voltage (IGBT) and varies outgoing frequency with a sinus valuated pulse width modulated output voltage. It works with controlled sinusoidal current synthesis and a dynamic overcurrent limitation. An adjustable high switching frequency of 8 khz prevents undesired noise from driving motors. Reactions to the feeder are prevented by a filter, and cooling is enhanced by the motor fan, or integral fan for wall mount versions.																
Terminals:	There is a terminal strip inside the AQUAVAR controller which will allow the connection of a wide range of external devices for display or control. When using these terminals, shielded wires need to be used. Unshielded wires may produce signal interference which will affect the inverter. Always use shielded wire.																
X1	<table><tr><td>1</td><td>Ground connection</td></tr><tr><td>2</td><td>Actual value input 4- 20 mA, 50 ohm load resistance. Used to connect external pressure transducer, flow meter, etc. Can also be used as input source from another device signalling actual speed when "actuator" is selected in controller mode.</td></tr><tr><td>3</td><td>Power source for external transducer 15 V DC, max. 100 mA current load</td></tr><tr><td>4</td><td>Ground connection for external on/off</td></tr><tr><td>5</td><td>External on/off connection, 10 kOhm resistance, 5 VDC gold plated contact. Note that the external device must have a switch suitable for < 10 V. If no outside panel or control is used, a <u>jumper wire</u> is installed on contacts 4 and 5 to prevent "INVERTER LOCKED".</td></tr><tr><td>6</td><td>Ground connection for low water switch or float.</td></tr><tr><td>7</td><td>Low water switch connection, 10 kOhm resistance, 5 VDC. This contact is where an external level switch, float switch or pressure switch from the suction line would be installed. If no suction pressure devices are used, a jumper wire is installed on contacts 6 and 7.</td></tr><tr><td>8</td><td>5 V power source for the Klixon thermostwitch mounted in the motor conduit box. 10 kOhm resistance.</td></tr></table>	1	Ground connection	2	Actual value input 4- 20 mA, 50 ohm load resistance. Used to connect external pressure transducer, flow meter, etc. Can also be used as input source from another device signalling actual speed when "actuator" is selected in controller mode.	3	Power source for external transducer 15 V DC, max. 100 mA current load	4	Ground connection for external on/off	5	External on/off connection, 10 kOhm resistance, 5 VDC gold plated contact. Note that the external device must have a switch suitable for < 10 V. If no outside panel or control is used, a <u>jumper wire</u> is installed on contacts 4 and 5 to prevent "INVERTER LOCKED".	6	Ground connection for low water switch or float.	7	Low water switch connection, 10 kOhm resistance, 5 VDC. This contact is where an external level switch, float switch or pressure switch from the suction line would be installed. If no suction pressure devices are used, a jumper wire is installed on contacts 6 and 7.	8	5 V power source for the Klixon thermostwitch mounted in the motor conduit box. 10 kOhm resistance.
1	Ground connection																
2	Actual value input 4- 20 mA, 50 ohm load resistance. Used to connect external pressure transducer, flow meter, etc. Can also be used as input source from another device signalling actual speed when "actuator" is selected in controller mode.																
3	Power source for external transducer 15 V DC, max. 100 mA current load																
4	Ground connection for external on/off																
5	External on/off connection, 10 kOhm resistance, 5 VDC gold plated contact. Note that the external device must have a switch suitable for < 10 V. If no outside panel or control is used, a <u>jumper wire</u> is installed on contacts 4 and 5 to prevent "INVERTER LOCKED".																
6	Ground connection for low water switch or float.																
7	Low water switch connection, 10 kOhm resistance, 5 VDC. This contact is where an external level switch, float switch or pressure switch from the suction line would be installed. If no suction pressure devices are used, a jumper wire is installed on contacts 6 and 7.																
8	5 V power source for the Klixon thermostwitch mounted in the motor conduit box. 10 kOhm resistance.																

Appendix B

AQUAVAR Controller Drive Head Technical Data and Terminals continued

- | | | |
|------|----|--|
| | 9 | Thermoswitch return connection. |
| | 10 | Ground connection for analog output. |
| | 11 | Analog output connection 0 - 10 Vdc, maximum 2 mA. Can be used to connect an outside meter or display panel to display actual pump running frequency or pressure as selected on the Analog Out part of the program. |
| | 12 | Current signal input 4-20mA. |
| | 13 | Voltage signal input 0-10V or 2-10V. |
| | 14 | Digital input. |
| X2 | 1 | Fault signal relay connection. This relay turns on the fault light on the control panel if a fault occurs. This relay may also be connected to an outside panel or display through connections 3, 4, and 5. Each is a maximum 250VAC connection with 1 Amp free of inductivity. Normally Open (NO). |
| | 2 | Common connection for fault signal relay. 250 VAC with 1 Amp free from inductivity. (CC) |
| | 3 | Normally open connection for fault signal relay. 250 VAC with 1 Amp free inductivity. Connection 3 is normally closed. (NC) |
| | 4 | Pump operation signal relay connection. This relay turns on the run light on the control panel when the pump is operating. This relay may also be connected to an outside panel or display through connections 6, 7, and 8. Each is a maximum of 250 VAC with 1 Amp free from inductivity. Connection 6 is normally closed. (NC) |
| | 5 | Common connection for the operation signal relay. 250 VAC with 1 Amp free inductivity. (CC) |
| | 6 | Normally open connection for pump operation signal relay. 250 VAC with 1 Amp free inductivity. (NO) |
| X5/6 | 1 | RS-485 interface connection. SIO - (low) for connection of the AQUAVAR controller to other AQUAVAR controller units in a set, or to an outside controller. |
| | 2 | RS-485 interface connection. SIO + (high) for connection of the AQUAVAR controller to other AQUAVAR controller units in a set, or to an outside controller. |
| | 3 | RS-485 interface connection. Common ground. |
| | 4 | RS-485 interface connection. +5 VAC output signal. Maximum 20 mAmp output current. |

Note

When using the RS-485 connection for multiple pump connection, connections (X5, 1, 2 and 3) must be connected with three core shielded wire to like connections on each AQUAVAR controller drive head. Always use shielded wire.

Appendix C

Interference Suppression Measures

Introduction

Electrical/electronic devices are capable of influencing or disturbing each other through connecting cables or other metallic connections. Interference suppression measures (electromagnetic compatibility) consists of two elements: interference resistance and interference emission.

Correct installation of the inverter in conjunction with any possible local interference suppression measures has a crucial effect on minimizing or suppressing mutual interference.

Guidelines for interference Suppression

The following guidelines assume a power source that is not contaminated by high frequency interference. Other measures may be necessary to reduce or suppress interference if the power source is contaminated, and no general recommendations can be given for such cases. Please consult G&L Applications Engineering Department if the following recommended interference suppression measures do not produce the desired result.

Guidelines are as follows:

- When dealing with RFI (radio frequency interference), the surface area of the conductors is a more critical consideration than its cross sectional area. Since high frequency interference does not flow through the entire cross section of the conductor, but tends to stay toward its outer surface (skin effect), braided copper tapes of equal cross section should be used.
- A central grounding point should be used for interference suppression. Route the ground cables radially from this point, avoiding loops which may lead to interference.
- The inverter and all components used for interference suppression, particularly the shield of the motor cable, should be connected over as large a surface area as possible when passing over metallic surfaces. Remove the paint from contact surfaces to ensure a good electrical connection. See Diagram 25 for recommended connection technique.

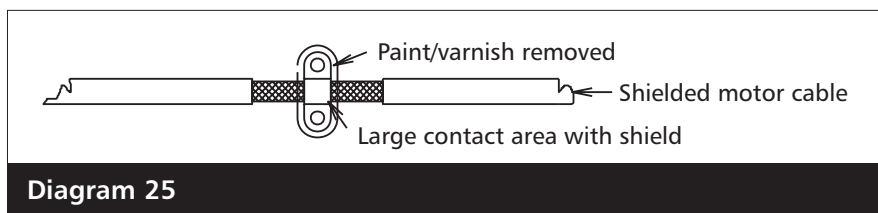

Appendix C

- Take care not to damage the shield cross section when connecting it to the continuing lines. This raises the RF resistance of the shield and radiates rather than discharges the RF energy traveling on the shield. Shields, particularly those on control cables, must not be routed through pin contacts (plug connectors).
- When shielded cables must pass through a plug connection, use the metallic hand guard of the plug for the continuation of the shield. It is strongly recommended that the shield be uninterrupted whenever possible.
- When selecting shielded cable for use as motor leads, it is important to select a cable which is designed for operation at the frequencies and power levels involved. Improper selection of motor cable can cause high potential to exist on the shield. This could cause damage to the inverter and other equipment and could pose a safety hazard.
- Separate power and control wiring. Never run transducer or RS485 wire in same conduit as the power wiring.
- Use metal conduit that is grounded.
- Keep peripheral devices and machines as far from the ground cables as possible. Where possible, use separate ground on the AQUAVAR.
- Do not use enclosure of AQUAVAR as ground. The enclosure itself should be grounded.
- Use shielded (armored VFD) cable for power cables. (i.e.: Belden wire and cable, Olflex cable.)

Appendix D

The final difference is the addition of a DIP switch SW4 which can be used to select a lower switching frequency. This could be used to improve the motor efficiency of submersible pumps, and overall power consumption. This will also increase the audible motor noise. Before changing this switch the AQUAVAR controller must be disconnected from the power supply. The switch settings are as follows:

<u>Switch 1</u>	<u>Switch 2</u>	<u>Switching Frequency</u>
Off	Off	8khz (standard)
On	Off	5khz
Off	On	4khz
On	On	2.5khz

Operating Instruction

Technical Data - Frequency Inverter

Output voltage:	Three phase unit:	3 x 400-460 V AC
Max. frequency:	See: max. Frequency	60 Hz
Min. frequency:	0 - f-max. (0 Hz or Fmin setting)	
Electrical Efficiency:	> 95%	

Note

If the motor and control unit are assembled separately keep the motor cable as short as possible in order to avoid electromagnetic emissions and capacitive currents. The length may not exceed 30 m (60 ft.) and a shielded cable must be used.

Protection against: Short circuit, under-voltage, overheating of the electronics (overload) and additional protective function via external switch (motor temperature, low water).

A mains filter is fitted to ensure interference immunity.

The HV Series frequency converter complies with the general EMV provisions and has been tested according to the following standards:

- Radio Interference Suppression EN 50081 Part 2 and EN 50082 Part 2
- High Frequency Field Interference ENV 50140 and ENV 50141
- Static Electricity Discharge EN 61000-4

Ambient temperature: 5° C – +35° C

Storage temperature: -24° C – +55° C (+70° C during max. 24 hours)

Humidity: rH max. 50% at 40° C Unlimited
rH max. 90% at 20° C Maximum 30 days per year
75% average per year (Class F, DIN 40 040)
Condensation not permitted!

Air pollution: The air may contain dry dust as found in workshops where there is no excessive quantity of dust due to machines. Excessive amounts of dust, acids, corrosive gases, salts etc. are not permitted.

Altitude: Maximum 3300' above sea level.
At higher altitudes the maximum available power has to be reduced.
Please ask the manufacturer for further details.
2% derate every 1000' above 3300'.

Class of protection: IP54, NEMA 4

Notes

Notes

GOULDS PUMPS LIMITED WARRANTY

This warranty applies to all water systems pumps manufactured by Goulds Pumps.

Any part or parts found to be defective within the warranty period shall be replaced at no charge to the dealer during the warranty period. The warranty period shall exist for a period of twelve (12) months from date of installation or eighteen (18) months from date of manufacture, whichever period is shorter.

A dealer who believes that a warranty claim exists must contact the authorized Goulds Pumps distributor from whom the pump was purchased and furnish complete details regarding the claim. The distributor is authorized to adjust any warranty claims utilizing the Goulds Pumps Customer Service Department.

The warranty excludes:

- (a) Labor, transportation and related costs incurred by the dealer;
- (b) Reinstallation costs of repaired equipment;
- (c) Reinstallation costs of replacement equipment;
- (d) Consequential damages of any kind; and,
- (e) Reimbursement for loss caused by interruption of service.

For purposes of this warranty, the following terms have these definitions:

- (1) "Distributor" means any individual, partnership, corporation, association, or other legal relationship that stands between Goulds Pumps and the dealer in purchases, consignments or contracts for sale of the subject pumps.
- (2) "Dealer" means any individual, partnership, corporation, association, or other legal relationship which engages in the business of selling or leasing pumps to customers.
- (3) "Customer" means any entity who buys or leases the subject pumps from a dealer. The "customer" may mean an individual, partnership, corporation, limited liability company, association or other legal entity which may engage in any type of business.

THIS WARRANTY EXTENDS TO THE DEALER ONLY.

AQUAVAR, G&L Pumps and Goulds Pumps are Tradenames and Trademarks of ITT Industries and its subsidiaries.

www.goulds.com