

# AQUAVAR®

Variable Speed  
Pump Control

New Sizes Addendum\*  
(August 2004)



#### Models covered:

- 04168321 - 2 HP - single phase, 230V
- 04168331 - 3 HP - single phase, 230V
- 04169131 - 5 HP - single/three phase, 230V\*
- 04169141 - 7½ HP - single/three phase, 230V\*
- 04169181 - 10 HP - single phase, 230V\*
- 04169151 - 10 HP - three phase, 230V\*
- 04168371 - 5 HP - three phase, 460V
- 04168491 - 7½ HP - three phase, 460V
- 04168501 - 10 HP - three phase, 460V



Goulds Pumps



ITT Industries

# AQUAVAR

## AQUAVAR Controller Technical Data:

AQUAVAR Controller		Motor		Supply Voltage 40-60 Hz	Recommended Circuit Protection (1)
Part Nos.	Rated Output	Voltage	Current		
04168321	2 HP	3 ph 230V	7A	Single Phase 240 VAC $\pm$ 10%	15 Ampere
04168331	3 HP	3 ph 230V	10A	Single Phase 240 VAC $\pm$ 10%	15 Ampere
04168371	5 HP	3 ph 460V	9A	Three Phase 380-460 VAC $\pm$ 15%	15 Ampere
04168491	7½ HP	3 ph 460V	13½A	Three Phase 380-460 VAC $\pm$ 15%	20 Ampere
04168501	10 HP	3 ph 460V	17A	Three Phase 380-460 VAC $\pm$ 15%	25 Ampere

AQUAVAR Controller (2)				Motor			Circuit Protection Single Phase INPUT (1)	Circuit Protection Three Phase INPUT (1)
Part Number	Rated Output (HP)	Supply Voltage 40-60 Hz	Input Frequency (Hz)	Input Phase	Voltage (V)	Current (A)	Fuse Size (A)	Fuse Size (A)
04169131	5	220-240 VAC $\pm$ 15%	48...62	1 or 3 ph	3 ph 230V	15	40	20
04169141	7½	220-240VAC $\pm$ 15%	48...63	1 or 3 ph	3 ph 230V	22	60	30
04169181	10	220-240VAC $\pm$ 15%	48...64	1ph only	3 ph 230V	28	70	NA
04169151	10	220-240VAC $\pm$ 15%	48...64	3ph only	3 ph 230V	28	NA	40

**NOTE:** (1) Recommended short circuit protection is UL Type T, very fast acting fuses.

(2) Dimensions are similar to the 5, 7½ and 10 HP, 3 phase, 460 Volt units.

## Dimensions and Weights

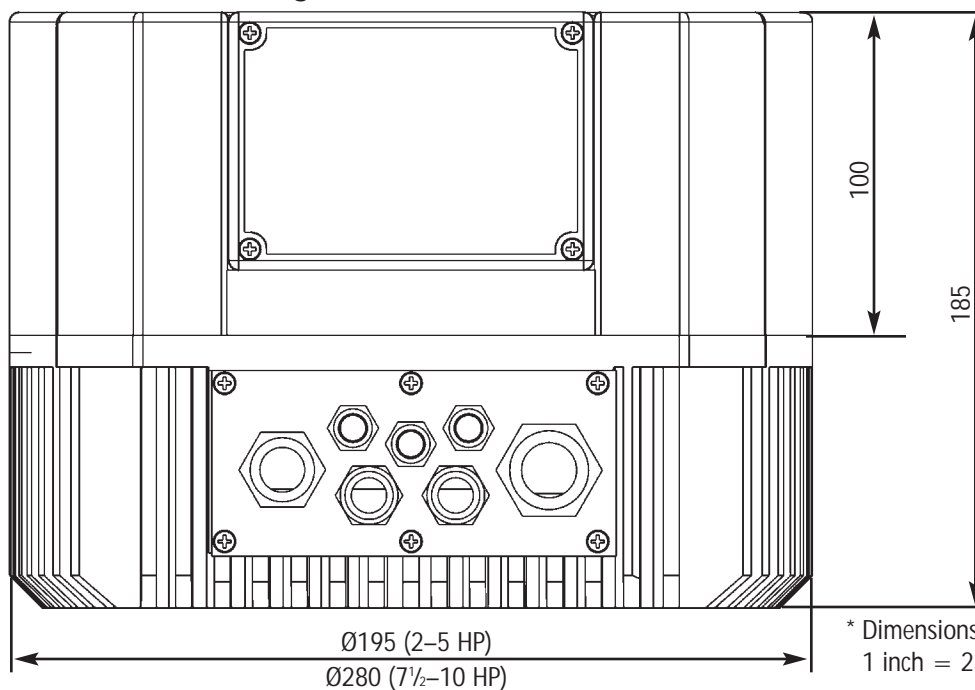

Part Nos.	Weight
04168321	12 lbs.
04168331	12 lbs.
04168371	12 lbs.
04168491	22 lbs.
04168501	22 lbs.

For other technical data,  
see Appendix B  
of IM043R07.

**NOTE:** All motors must be  
at least 3 phase, TEFC,  
Class B design.

\* Dimensions are in mm.  
1 inch = 25.4 mm

# AQUAVAR

## Electrical Connections (Line Reactors)

### Input Line Requirements

#### Line Voltage

See the Power and Current Ratings table for the allowable fluctuation of AC line voltage for your particular model. A supply voltage above or below the limits given in the table will cause the drive to trip with either an overvoltage or undervoltage fault.

To verify power quality, consult your local power utility for a chart recorder.

Exercise caution when applying the AQUAVAR controller on low-line conditions.

For example, an AQUAVAR controller will operate properly on a 208 Vac line – but the maximum output voltage will be limited to 208 Vac. Now if a motor rated for 230 Vac line voltage is controlled by this drive, higher motor currents and increased heating will result.

Therefore, ensure that the voltage rating of the motor matches the applied line voltage.

#### Use of Isolation Transformers and Line Reactors

The AQUAVAR controller is perfectly suitable in most cases for direct connection to a power source as specified in this manual and the technical nameplate affixed to the unit. There are however a few cases where a properly sized isolation transformer or line reactor should be employed to minimize the risk of drive malfunction, damage or nuisance tripping:

- As noted in *Table 7*, transformer sizing, when line capacity is greater than 10 times the KVA rating of the drive. Consult the factory for assistance in sizing the line reactor.
- When power factor correction capacitors are employed on the drive's power source.
- When the power source is known to be subject to transient power interruptions or significant voltage spikes.
- When the power source supplying the drive also supplies large devices such as DC drives that contain controller rectifiers.
- When power quality or known transient voltage spikes is suspected or questioned.

**Table 7: Transformer Sizing for the AQUAVAR Controller**

Controller HP	1	2	3	5	7.5	10	15	20	25	30	40	50	60	75
Transformer kVA	2	4	5	9	13	18	23	28	36	42	56	70	90	112

\* Consult factory for more information, if needed.

# AQUAVAR

## Mounting Procedure

### Components Included

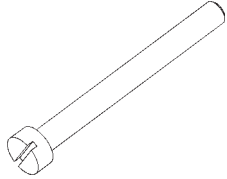

(4) Screw M 5 x 60

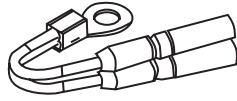

(1) Thermal Resistor

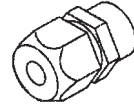

Cable Gland

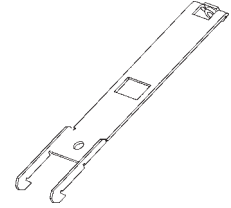

(4) Motor Mounting Clamp

### Mounting

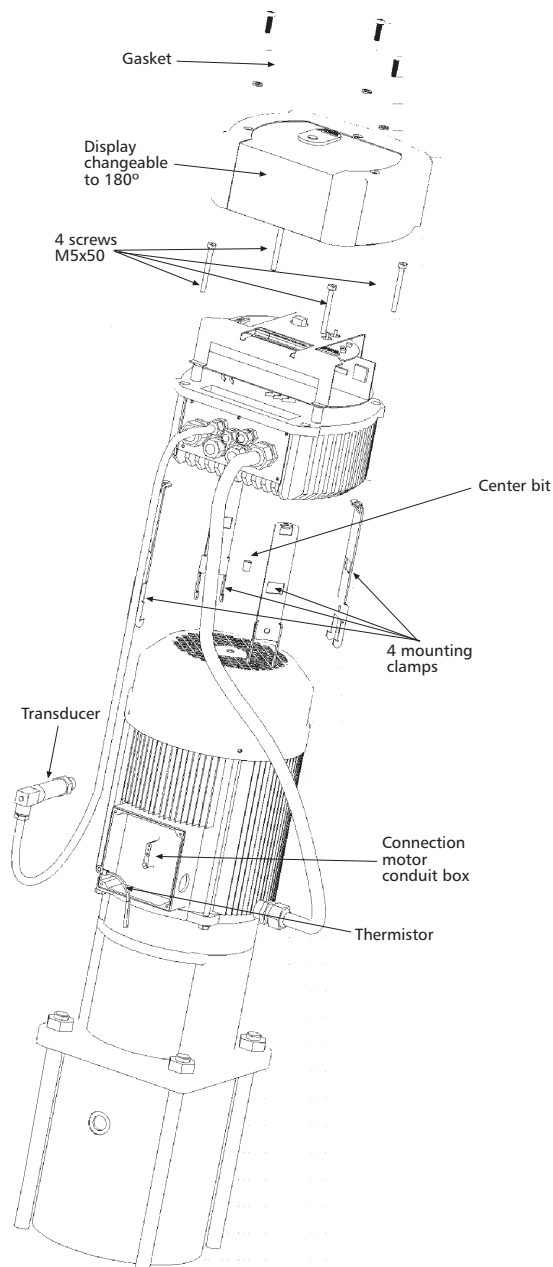

### Mounting:

- Remove the 3 screws from the AQUAVAR cover.
- Place the center bit in the AQUAVAR heat sink.
- Place the AQUAVAR on the motor.
- Hang the 4 clamps by the heat sink and mount with the 4 screws.
- Mount the cover with the 3 screws (remember to use the gaskets).
- Depending on pump orientation, the display can be rotated 180°.

# AQUAVAR

## Wiring Procedure

– Single Phase Connections (2, 3, 5, 7½ and 10 HP)

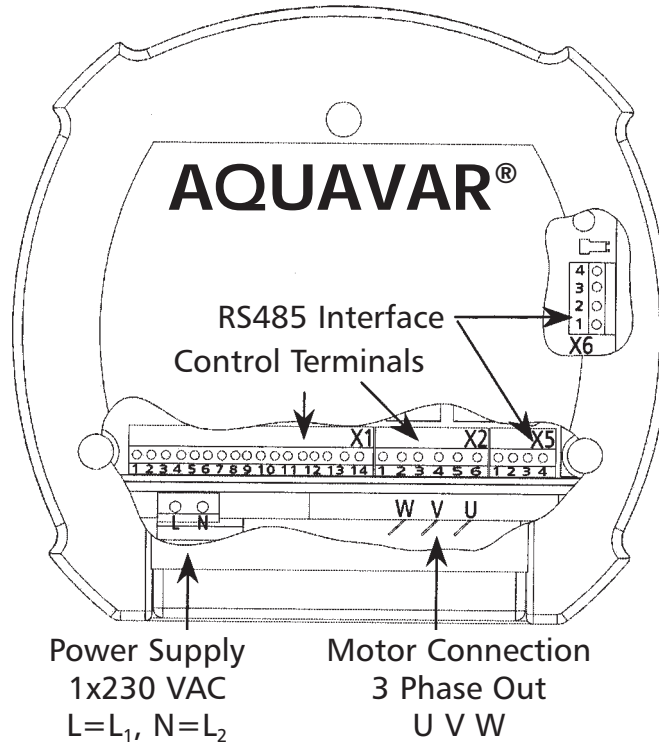

– Three Phase Connections (5, 7½, 10 and 15 HP)

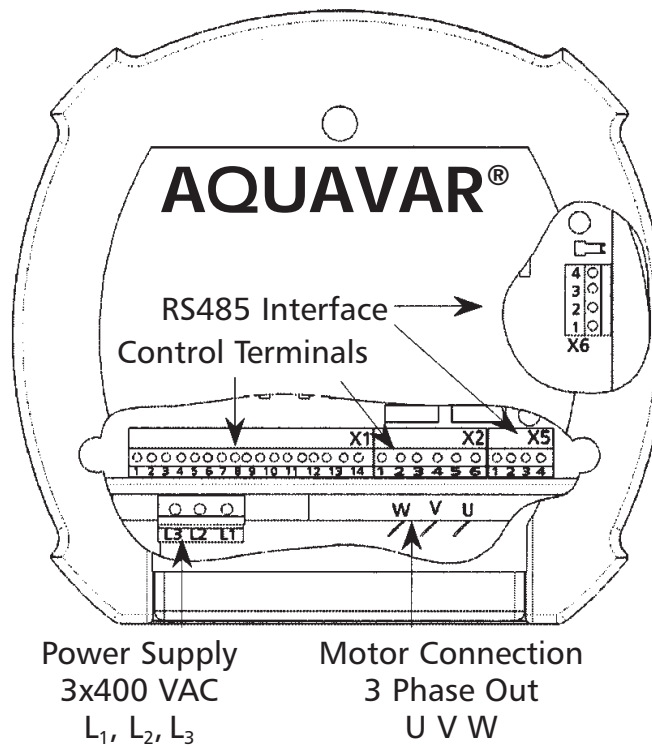

# AQUAVAR

## Main Parts of the Control Board (PN# 2509641)

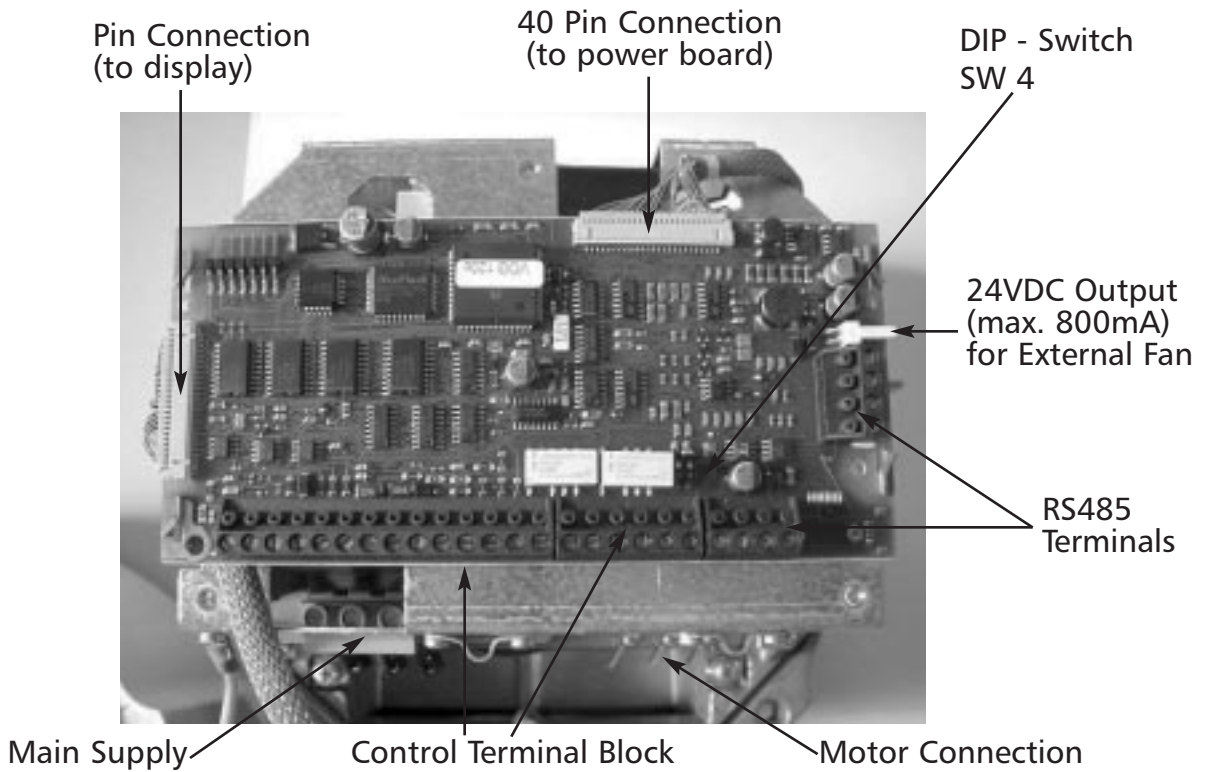

## Dip-Switch on the Controller Board

SW4: DIP-Switch to Select the Switching Frequency

**⚠ ATTENTION**

Before switching, disconnect the power supply, otherwise the AQUAVAR could be destroyed.

SW 4		Switching Frequency
1	2	
OFF	OFF	8 kHz (Standard)
ON	OFF	5 kHz
OFF	ON	4 kHz
ON	ON	2.5 kHz*

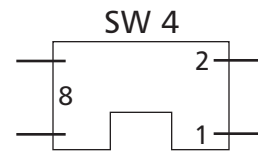

\*Recommended for submersible motors.

**NOTE**

Lower switching frequencies reduce heat in motor, but increase audible noise.

For complete wiring procedures, refer to page 18 of IM043R07.

For complete programming procedures, refer to page 26 of IM043R07.

# AQUAVAR

## Front Plate

The diagram below shows the location of the programming keys and displays on the new AQUAVAR models. Use this illustration with the programming steps in IM043R07.

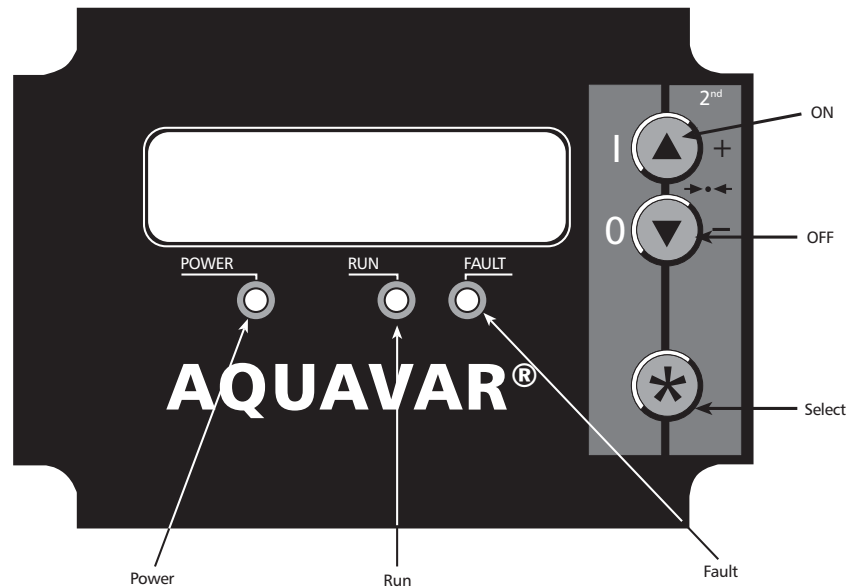

### AQUAVAR LIMITED WARRANTY

This warranty applies to all new style AQUAVAR controllers referenced on the front of this booklet. Any part or parts found to be defective within the warranty period shall be replaced at no charge to the distributor during the warranty period. The warranty period shall exist for a period of twenty four (24) months from date of installation or thirty (30) months from date of manufacture, whichever period is shorter. A dealer who believes that a warranty claim exists must contact the authorized Goulds Pumps distributor from whom the AQUAVAR was purchased and furnish complete details regarding the claim. The distributor is authorized to adjust any warranty claims utilizing the Goulds Pumps Customer Service Department.

**The warranty excludes:**

- (a) Labor, transportation and related costs incurred by the dealer;
- (b) Reinstallation costs of repaired equipment;
- (c) Reinstallation costs of replacement equipment;
- (d) Consequential damages of any kind; and,
- (e) Reimbursement for loss caused by interruption of service.

**For purposes of this warranty, the following terms have these definitions:**

- (1) "Distributor" means any individual, partnership, corporation, association, or other legal relationship that stands between Goulds Pumps and the dealer in purchases, consignments or contracts for sale of the subject pumps.
- (2) "Dealer" means any individual, partnership, corporation, association or other legal relationship which engages in the business of selling or leasing pumps to customers.
- (3) "Customer" means any entity who buys or leases the subject AQUAVAR from a dealer. The "customer" may mean an individual, partnership, corporation, limited liability company, association or other legal entity which may engage in any type of business.

**THIS WARRANTY EXTENDS TO THE DEALER ONLY.**

Goulds Pumps is a brand of ITT Water Technology, Inc. -  
a subsidiary of ITT Industries, Inc.

AQUAVAR, G&L Pumps and Goulds Pumps and  
the ITT Engineered Blocks Symbol are registered  
trademarks and tradenames of ITT Industries.

[www.goulds.com](http://www.goulds.com)

©2004 ITT Water Technology, Inc.  
September, 2004  
Printed in U.S.A.

1 Goulds Drive  
Auburn, NY 13021

Goulds Pumps



ITT Industries