



Submersible Sewage Pump

MODEL 3888D4

WS_D4 Series

APPLICATIONS

Used in a variety of residential, commercial and industrial applications such as:

- Sewage systems
- Flood and pollution control
- Dewatering/Effluent
- Farms
- Hospitals
- Trailer courts
- Motels

SPECIFICATIONS

Pump:

- Maximum solid size: 3"
- Discharge size: 4", 125 # ANSI flange
- Maximum capacity: 620 GPM
- Maximum total head: 60 feet
- 300 Series stainless steel fasteners
- 20' Power cord
- Standard silicon carbide/silicon carbide outer seal

Motor:

- Maximum ambient temperature:
 - 104° F (40° C) continuous duty
 - 140° F (60° C) intermittent duty

- Rated for continuous duty when fully submerged
- Insulation: Class B
- 60 Hertz
- Single row ball bearings
- 300 Series stainless steel keyed shaft

Single Phase:

- 1.5 - 5 HP
- 208 and 230 volts
- Built-in thermal overloads with automatic reset
- Built-in capacitors

Three Phase:

- 1.5 - 7.5 HP
- 200, 230, 460 and 575 volts
- Class 10 overload protection must be provided in control panel

FEATURES

- **Impeller:** Cast iron, two vane semi-open, non-clog with pump-out vanes for mechanical seal protection. Balanced for smooth operation. Silicon bronze impeller available as an option.
- **Casing:** Heavy duty cast iron, volute type for maximum efficiency. 4" flange conforms to 125 # ANSI standard. Connects to A10-40 or A10-60 guide rail system.

■ Dual Mechanical Seals:

Silicon carbide vs. silicon carbide outer seal and ceramic vs. carbon inner seal, stainless steel metal parts, BUNA-N elastomers. Upper and lower shaft seals are positioned independently and are separated by an oil-filled chamber.

■ Shaft:

300 series stainless steel keyed design.

■ Fasteners:

300 series stainless steel.

■ Capable of running dry

without damage to components.

■ Bearings:

Upper and lower heavy duty ball bearing construction for precision positioning of parts and to carry thrust loads.

■ Power Cable:

Severe duty rated, oil and water resistant. Epoxy seal on motor end provides secondary moisture barrier in case of outer jacket damage and to prevent oil wicking. 20 foot standard with optional lengths available.

■ O-ring:

Assures positive sealing against contaminants and oil leakage.

MOTORS

- Fully submerged in oil-filled chamber. High grade turbine oil surrounds motor for more efficient heat dissipation, permanent lubrication of bearings and mechanical seal for complete protection against outside environment.

■ Class B insulation.

- **Designed for Continuous Operation:** Pump ratings are within the motor manufacturer's recommended working limits and can be operated continuously without damage when fully submerged.

AGENCY LISTINGS



Tested to UL 778 and CSA 22.2 108 Standards By Canadian Standards Association File #LR38549

Goulds Pumps is ISO 9001 Registered.

MODEL AND MOTOR INFORMATION

Order No.	HP	Phase	Volts	RPM	Impeller		Maximum Amps	L.R. Amps	KVA Code	Power Cable	F.L. Motor Efficiency %	Resistance		Wt. (lbs.)	
					Dia. (in.)	Code						Start	Line-Line		
WS1518D4M	1.5	1	208	1750	5.63	E	17.2	50.8	F	14/3	80	1.1	0.9	195	
WS1512D4M			230				13.2	32.7	H		73	1.5	1.4		
WS1538D4M		3	200				11.5	43.0	K	14/4	81	NA	1.7		14.8
WS1532D4M			230				10.0	40.0	E		81		2.3		
WS1534D4M			460				5.0	20.0	E		74		9.3		
WS1537D4M			575				4.0	11.8	B		74		14.8		
WS1518D4	1.5	1	208	1750	6.25	D	17.2	50.8	F	14/3	80	1.1	0.9	195	
WS1512D4			230				13.2	32.7	H		73	1.5	1.4		
WS1538D4		3	200				11.5	43.0	K	14/4	81	NA	1.7		14.8
WS1532D4			230				10.0	40.0	E		81		2.3		
WS1534D4			460				5.0	20.0	E		74		9.3		
WS1537D4			575				4.0	11.8	B		74		14.8		
WS2018D4	2	1	208	1750	6.63	C	20.3	50.8	D	14/3	80	1.1	0.9	200	
WS2012D4			230				16.3	37.4	H		76	1.4	1.3		
WS2038D4		3	200				13.3	43.0	F	14/4	81	NA	1.7		14.8
WS2032D4			230				11.6	40.0	F		83		2.3		
WS2034D4			460				5.8	20.0	H		83		9.3		
WS2037D4			575				4.6	14.4	B		74		14.8		
WS3018D4	3	1	208	1750	7.00	B	25.5	50.8	C	10/3	80	1.1	0.9	208	
WS3012D4			230				21.5	46.4	G		79	1.0	1.0		
WS3038D4		3	200				16.6	43.0	H	14/4	85	NA	1.3		11.6
WS3032D4			230				14.4	49.5	H		83		1.9		
WS3034D4			460				7.2	24.8	G		83		7.5		
WS3037D4			575				6.6	17.3	A		78		11.6		
WS5012D4	5	1	230	1750	7.25	A	26.5	57.7	F	10/3	80	1.0	0.8	210	
WS5038D4			200				19.1	77.8	E	10/4	84	NA	0.9		
WS5032D4		3	230				16.6	63.6	E		85		1.2		
WS5034D4			460				8.3	31.8	E	14/4	85	4.8			
WS5037D4			575				6.6	22.8	G		80	7.4			
WS7532D4	7.5	3	230	1750	7.69	F	23.0	105.0	G	10/4	83	NA	0.7	225	
WS7534D4			460				11.5	53.0	E	14/4	83		2.8		
WS7537D4			575				9.2	50.0	E		84		4.4		

Submersible Sewage Pump

MODEL 3888D4

WS_D4 Series

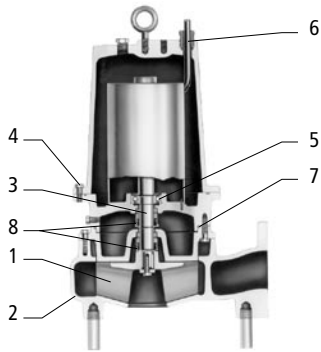

DIMENSIONS

(All dimensions are in inches. Do not use for construction purposes.)

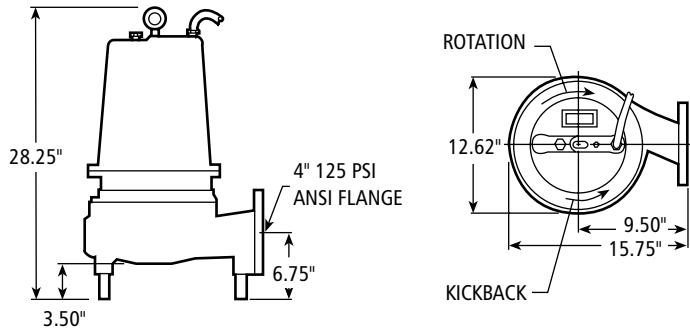

MATERIALS OF CONSTRUCTION

Item No.	Part Name	Material				
		Standard	Optional			
1	Impeller, non-clog	1003	1179			
2	Casing	1003				
3	Shaft-keyed	300 Series SS				
4	Fasteners	300 Series SS				
5	Ball bearings	Steel				
6	Power cable	STOW, 20 feet	Additional lengths			
	Seal sensor cable					
7	O-ring	BUNA-N				
8	Outer Mech. Seal	Service	Rotary	Stationary	Elastomers	Metal Parts
	OPT	Heavy duty	Silicon Carbide	Tungsten Carbide	BUNA-N	300 Series SS
	STD	Mild abrasives	Silicon carbide		BUNA-N	300 Series SS
Material Code		Engineering Standard				
1003		Cast iron — ASTM A48 Class 30				
1179		Silicon bronze — ASTM C87600				

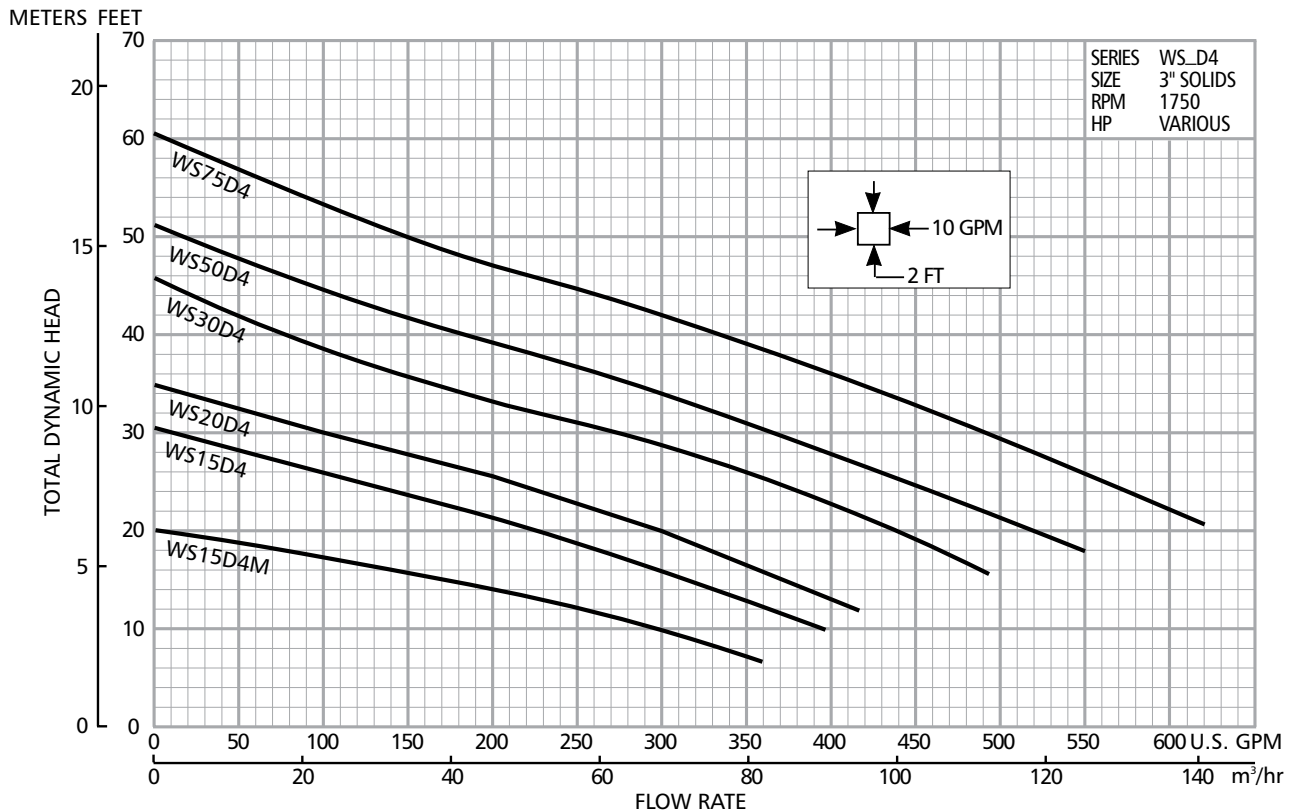

Goolds Pumps

APPLICATION DATA

Maximum Solid Size	3"
Minimum Casing Thickness	5/16"
Casing Corrosion Allowance	1/8"
Maximum Working Pressure	30 PSI
Maximum Submergence	50 feet
Minimum Submergence	Fully submerged for continuous operation
	6" below top of motor for intermittent operation
Maximum Environmental Temperature	40° C (104° F) continuous operation
	60° C (140° F) intermittent operation

CONSTRUCTION DETAILS

Power Cable – Type (See Motor Information for AWG data/size.)	Type SJTOW: single phase, 1½ and 2 HP
	Type STOW: single phase, 1½ – 3 HP and 5 HP, 460 V
	Type STOW: single phase, 3 & 5 HP, three phase 5 HP, 230 V and 7½ HP
Motor Cover	Gray Cast Iron – ASTM A48, Class 30
Bearing Housing	Gray Cast Iron – ASTM A48, Class 30
Seal Housing	Gray Cast Iron – ASTM A48, Class 30
Casing	Gray Cast Iron – ASTM A48, Class 30
Impeller	Gray Cast Iron – ASTM A48 or Cast Bronze – ASTM B584 C87600
Motor Shaft	AISI 300 Series Stainless Steel
Motor Design	NEMA 56 Frame, oil filled with Class B Insulation
Motor Overload Protection	Single phase: on winding thermal overload protection auto reset
	Three phase: requires Class 10 overloads in control panel
External Hardware	300 Series Stainless Steel
Impeller Type	Semi-open with pump out vanes on back shroud
Oil Capacity – Seal Chamber	1.5 quarts
Oil Capacity – Motor Chamber	1½-5 HP single and three phase: 7 quarts
	7½ HP three phase: 6.5 quarts

STANDARD PARTS

Ball Bearing – Upper	1½ – 5 HP single and three phase: single row ball – SKF™ 6204-2Z
	7½ HP three phase: single row ball – SKF™ 6204-2Z
Ball Bearing – Lower	1½ – 5 HP single and three phase: single row ball – SKF™ 5206-2Z
	7½ HP three phase: double row ball – SKF™ 5206-2Z
Mechanical Seals – Standard	Upper Carbon/Ceramic; Type 21
	Lower Silicon Carbide/Silicon Carbide; Type 31
Mechanical Seals – Optional Lower	Silicon Carbide/Tungsten Carbide; Type 31
O-Ring – Stuffing Box	BUNA-N, AS 568A-265
O-Ring – Motor Cover	BUNA-N, AS 568A-374

Goulds Pumps is a brand of ITT Water Technology, Inc.
- a subsidiary of ITT Industries, Inc.

Goulds Pumps and the ITT Engineered Blocks Symbol are registered trademarks and tradenames of ITT Industries.