

# Frame-Mounted Centrifugal Pumps

MODEL

# 3742

1/2 to 3 HP

## FEATURES

- **Construction:** Available in bronze-fitted (BF), all iron (AI), or all bronze (AB). Bronze-fitted means bronze impeller.
- **Frame-Mounted Design:** Flexibility of installation and driver arrangements.
- **Back Pull-Out Design:** Simplifies maintenance when used with spacer type coupling.
- **Cast Iron Power Frame:** Rigidly supported, grease-for-life ball bearing assembly.
- **Impeller:** Enclosed design for high efficiencies. Threaded directly on pump shaft. Stainless steel locknut on three phase models. Requires no clearance adjustments. Balanced for smooth operation.

- **Mechanical Seal:** Standard John Crane Type 6 with carbon versus ceramic faces, BUNA elastomers, and 18-8 stainless metal parts. Optional high temperature and chemical duty seals available.
- **Motors:** NEMA standard open drip-proof, totally enclosed fan cooled or explosion proof enclosures. Rugged ball bearing design for continuous duty under all operating conditions.

## APPLICATIONS

- Specifically designed for a broad range of general applications traditionally requiring various materials such as all iron, bronze-fitted or all bronze construction.
- Water circulation
  - Booster service
  - Liquid transfer
  - Spray systems
  - Jockey pumps
  - OEM applications
  - General water services

## SPECIFICATIONS

- **Capacities to:** 108 GPM
- **Heads to:** 116 feet
- **Working pressures to:** 100 PSI
- **Maximum temperatures to:** 212°F (100°C) with standard seal or 250°F (121°C) with optional high temperature seal.
- **Direction of rotation:** Clockwise when viewed from motor end.
- **Motors:** T-Frame single and three phase. Open drip-proof, TEFC or explosion proof enclosures are available for 60 Hz, 3500, and 1750 RPM operation. For three phase motors, overload protection must be provided in starter unit. Starter and heaters must be ordered separately.
- **Accessories:** Rigid steel bedplate, sheet metal coupling guard designed to OSHA specifications and spacer type couplings.

Goulds Pumps is ISO 9001 Registered.

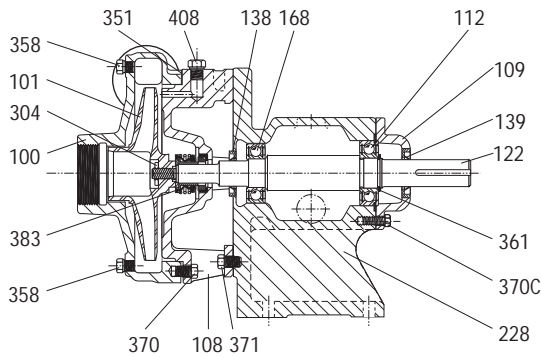

**Mechanical Seal Item 383						
Part No.	Service	Rotary	Stationary	Elastomer	Metal Parts	Crane Type
10K10	Standard Duty	Carbon	Ceramic	BUNA	316 SS	6
10K6	Fluct. Temp up to 212° F		Ni-Resist		18-8 SS	
10K18	Hot Water up to 250° F		Sil.-Carbide	EPR	316 SS	21
10K55	Mild Chemical		Ceramic	Viton		

**MATERIALS OF CONSTRUCTION**

Item No.	Description	Materials
100	Casing	Cast Iron or Bronze
101	Impeller	
108	Adapter Frame	Cast Iron
109	Bearing Cover	
112	Ball Bearing (outboard)	Steel
122	Shaft	AISI 303 SS
138	Lip-seal (inboard)	BUNA/Steel
139	Lip-seal (outboard)	BUNA/Steel
168	Ball Bearing (inboard)	Steel
228	Bearing Frame	Cast Iron
304	Impeller Locknut	AISI 416 SS
351	Gasket	Composite
358	Drain and Vent Plug, Casing	Plated Steel or Brass
361	Retaining Ring	Steel
370	Socket, Head Screw, Casing	Plated Steel
370C	H.H. Screw, Bearing Cover	Plated Steel
371	H.H. Screw, Bearing Frame	Plated Steel
383	Mechanical Seal	**See Chart
408	Priming Plug	Plated Steel or Brass

**PUMP DIMENSIONS AND WEIGHTS**

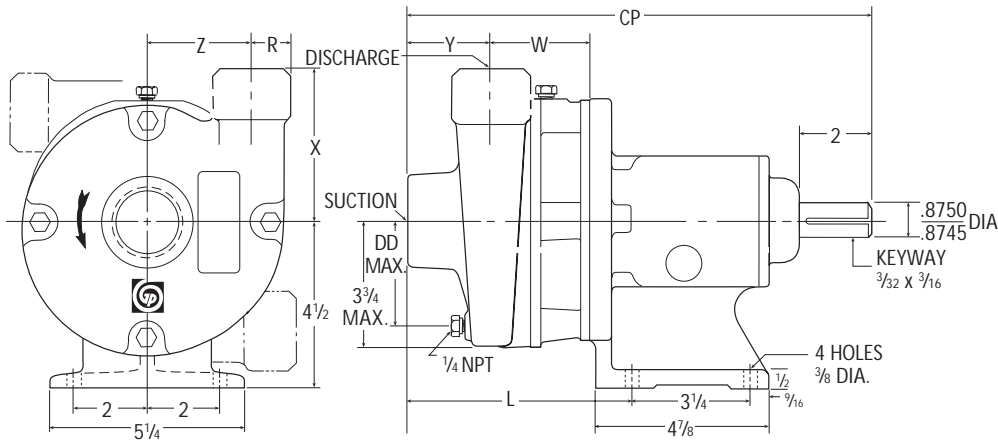

Pump	Suction*	Discharge*	CP	DD Max.	L	R	W	X	Y	Z	Wt. (lbs.)
1 x 1 1/4 - 5	1 1/4	1	12 1/4	3 1/4	5 13/16	1 5/16	2 1/2	4 1/8	2 2/16	3 1/16	45
1 1/4 x 1 1/2 - 5	1 1/2	1 1/4	12 1/2	3 3/8	6 1/8	1 1/16	2 3/4	4	2 1/4	2 15/16	48

\* NPT Connections

**NOTES:**

1. Pumps will be shipped with top vertical discharge as standard. For other orientations, remove casing bolts, rotate to desired position, replace and tighten 3/8 - 16 bolts to 37 lb. / ft.
2. Not to be used for construction purposes.
3. Dimensions in inches