



3656/ 3756 M & L- Group

**Cast Iron
Bronze Fitted
End-Suction
Flanged Pumps**

*Bombas
horizontales
con brida en
hierro fundido o
hierro fundido
y bronce*



A Full Range of Product Features

The 3656 and 3756 M & L-Group pumps from Goulds have been designed with technical benefits to meet the needs of users in a variety of water supply, recirculation, and cooling applications.

- The model 3656 offers close coupled design for space saving and simplified maintenance.
- The model 3756 offers a bearing frame mounted design for flexibility of installation and drive arrangements.
- SAE drive sizes 1 through 5 available on all pumps.
- Back pull-out to reduce maintenance down time.
- Standard Type 21 mechanical seal for both reliability and availability. Carbon/ceramic/BUNA standard, with other faces and elastomers available.
- Available in packed stuffing box design with Teflon™ impregnated packing, split Teflon lantern ring, tapped flush connection and 2 piece investment cast interlocking gland, all standard.
- Available in all iron or bronze fitted construction for application versatility.

- Replaceable wearing components include stainless steel shaft sleeve and casing and hub wear rings to maintain peak efficiency.
- Enclosed impeller design, dynamic balancing and renewable wear rings reduce losses affecting performance and pump life.
- 125 Class ANSI flange suction/discharge connections and casing rotation for piping connection versatility.
- NPT threaded connections are supplied on 1½ x 2 – 10 and 2½ x 3 – 8 models.
- Optional rigid carbon steel bedplate, sheet metal coupling guard and T. B. Woods spacer coupling for 3756 models.
- Standard NEMA motor frame, JM shaft extension (mechanical seal) JP shaft extension (packed box), C face mounting, single phase or three phase, 3500 or 1750 RPM for 60 Hz, 2900 or 1450 RPM for 50 Hz. Open drip-proof and totally enclosed fan cooled.
- Optional explosion proof and high efficiency motors are available.

Una amplia gama de variadas características

Las bombas 3656 y 3756 del Grupo M y L de Goulds han sido diseñadas con beneficios técnicos para satisfacer las necesidades de los usuarios en variadas aplicaciones de suministro y recirculación de agua y aplicaciones de refrigeración.

- El modelo 3656 cuenta con diseño de acoplamiento corto para ahorrar espacio y simplificar el mantenimiento.
- El modelo 3756 cuenta con diseño de montaje sobre bastidor que ofrece gran flexibilidad en los arreglos de instalación y accionamiento.
- Desmontaje posterior que reduce el tiempo de inactividad por mantenimiento.
- Sello mecánico estándar Tipo 21 brinda gran confiabilidad y asegura la disponibilidad. Estándar de carbono/cerámica/BUNA, también se encuentran disponibles con otras caras y elastómeros.
- Disponibles en diseño con caja prensaestopas con empaque de Teflon™ impregnado, aro de linterna de Teflon dividido, conexión de lavado con derivación y glándula fundida de conexión de inversión de 2 piezas, todo estándar.
- Fabricadas en todo hierro o con accesorios de bronce para una mayor versatilidad de aplicación.
- Los componentes de desgaste reemplazables incluyen los anillos de desgaste de la carcasa y del rodete y la camisa del eje, de acero inoxidable, para mantener la eficiencia pico.
- El diseño de impulsor encerrado, balanceo dinámico y anillos de desgaste reemplazables reducen las pérdidas que afectan el desempeño y la vida de la bomba.
- Conexiones de succión y descarga con brida ANSI de 125 Clase y carcasa rotativa para mayor versatilidad de conexión.
- Los modelos 1½ x 2 – 10 y 2½ x 3 – 8 cuentan con conexiones NPT.
- Placa de asiento rígida de acero al carbono, protector de acoplamiento de chapa metálica y acoplamiento espaciador T. B. Woods disponibles como opción en los modelos 3756.
- Bastidor de motor NEMA estándar, extensión de eje JM (sello mecánico), extensión JP (caja prensaestopas), montaje en cara C, monofásico o trifásico, 3500 ó 1750 RPM para 60 Hz, 2900 ó 1450 para 50 Hz. Abierto a prueba de filtraciones o totalmente encerrado enfriado por ventilador.
- Motores a prueba de explosiones y de alta eficiencia disponibles como opción.

Goulds Pumps is ISO 9001 Registered.

Performance Coverage
Campo de desempeño

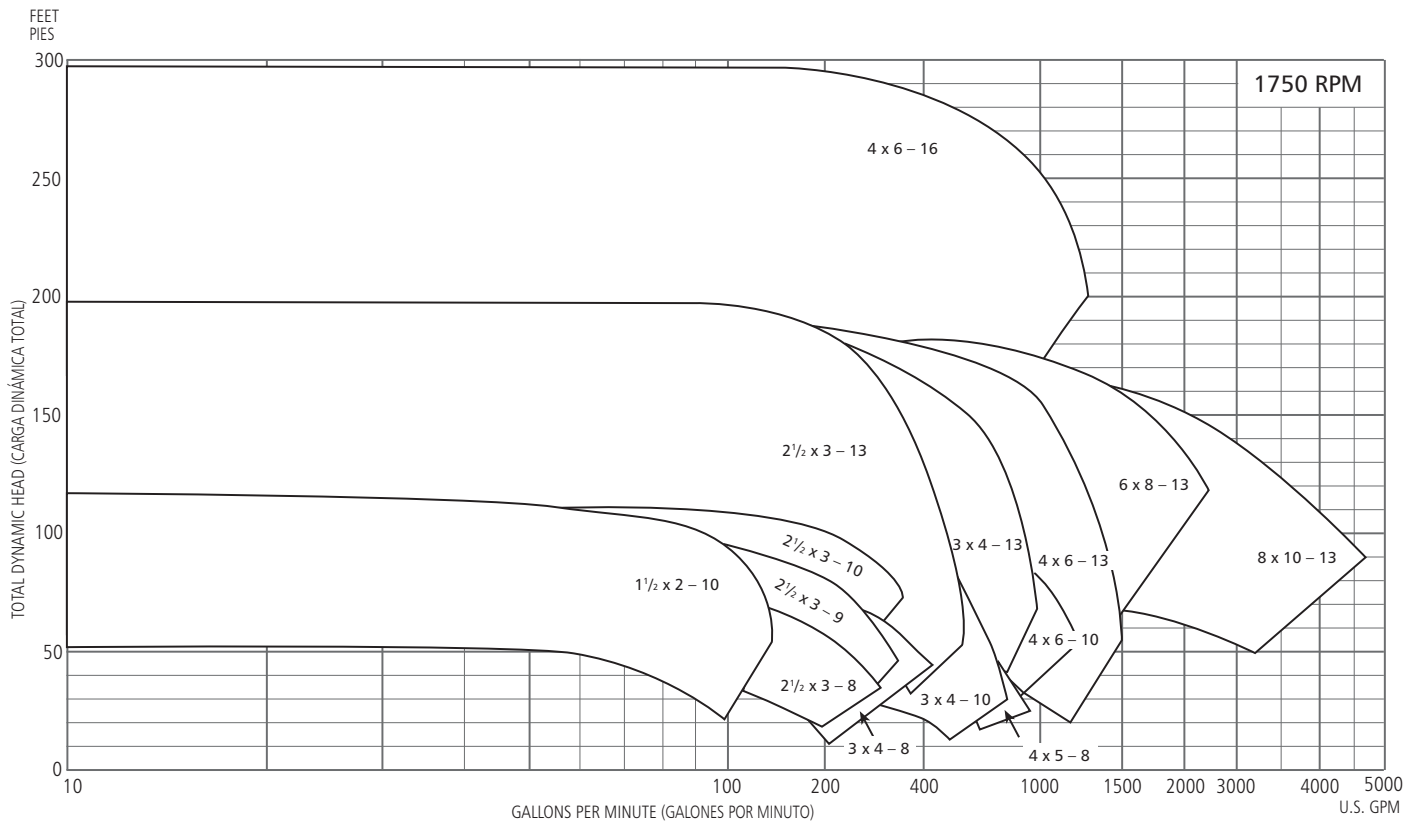
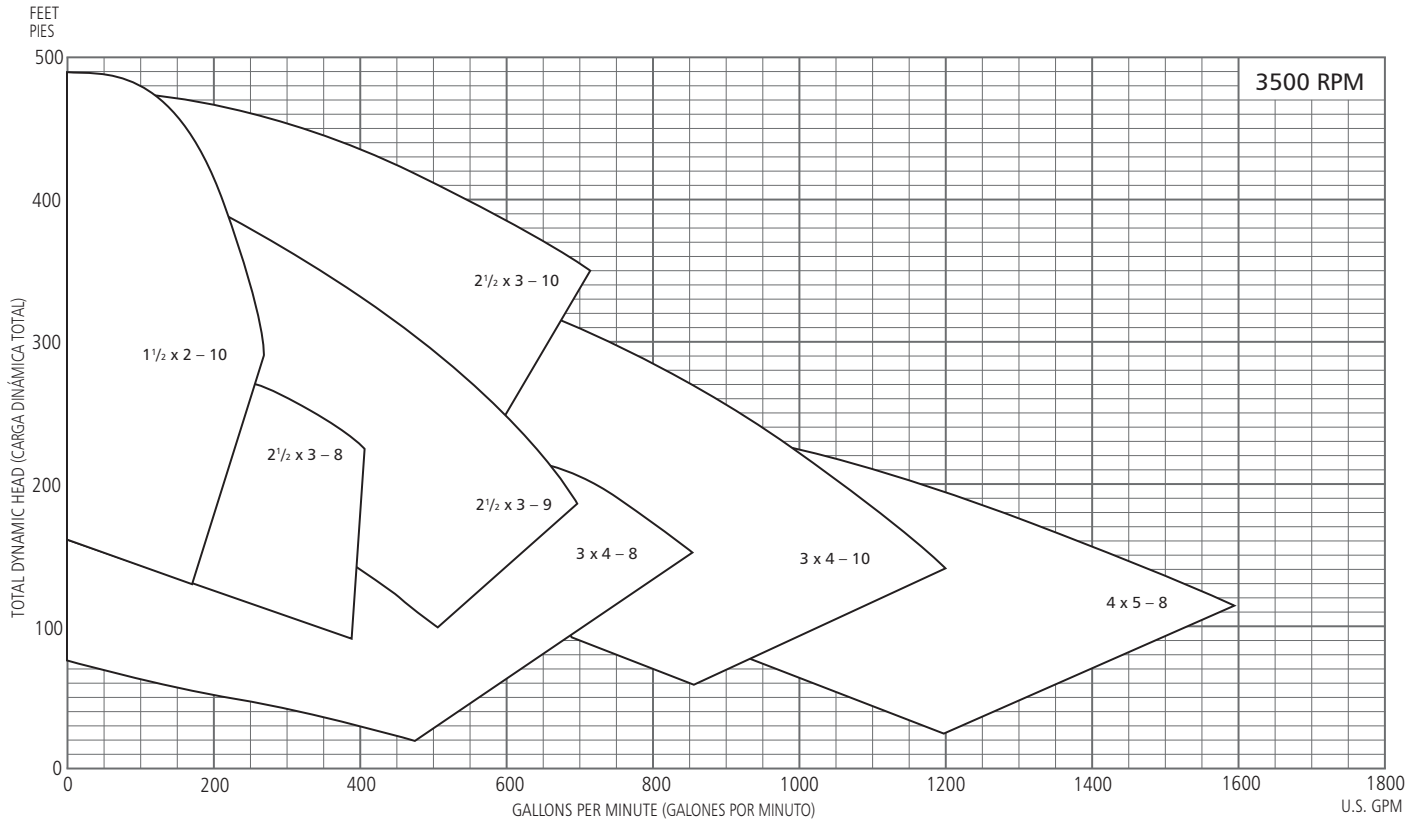

3656/3756 M & L-Group Numbering System

Sistema de numeración del Grupo M y L, modelos 3656/3756

The various versions of the 3656 and 3756 M & L-Group are identified by a product code number on the pump label. This number is also the catalog number for the pump. The meaning of each digit in the product code number is shown below. Not all combinations are possible; consult your G&L distributor for specific requirements.

Las diferentes versiones de los modelos 3656 y 3756 del Grupo M Y L se identifican con un número de código de producto en la etiqueta de la bomba. Este número es también el número de catálogo de la bomba. A continuación se ilustra el significado de cada dígito en el código del producto. No todas las combinaciones son posibles, consulte a su distribuidor G&L para requisitos específicos.

Example Product Code, Ejemplo del código de producto

11 BF 2 L 5 A 0

Mechanical Seal/Packed Box and O-ring Material, Materiales del sello mecánico/empaque y anillo en O

For Optional Mechanical Seal modify catalog order no. with Seal code listed below.

Para sellos mecánicos optativos, modificar el número de pedido del catálogo con los códigos de sello que se indican a continuación.

| Seal Code, Código del Sello | Rotary, Rotativo | Stationary, Estacionario | Elastomers, Elastómeros | Metal Parts, Partes Metálicas | Part No., Pieza Número | | |
|-----------------------------|--|--------------------------------|-------------------------|-------------------------------|------------------------|--------------|------------------|
| | | | | | M-Group, Grupo-M | | L-Group, Grupo-L |
| | | | | | 1.25" Shaft | 1.625" Shaft | |
| 0 | Carbon, Carbone | Ceramic, Cerámica | BUNA-N | 316 SS, 316 Acero inoxidable | 10K13 | 10K16 | 10K84 |
| 1 | | Sil-Carbide, Carburo de sílice | EPR | | 10K19 | 10K20 | NA |
| 3 | | | Viton | | 10K27 | 10K45 | 10K112 |
| 5 | NA | | | | NA | 10K144 | |
| 8A* | Sil-Carbide | | | | 10K64 | | 10K65 |
| 8B** | | | | | 10K64 | 10K65 | |
| 9*** | Packed Box Design with BUNA O-Ring, Diseño de prensaestopas empacado con anillo en O de BUNA | | | | 15K17 | 15K3 | 15K4 |

* Prime-Safe option with oiler, Opción Primero-Segura con el engrasador ** Prime-Safe option with grease, Opción Primero-Segura con la grasa

*** All Packed Box Units use JP style motors, Todas las unidades de prensaestopas empacado utilizan motores estilo JP

Impeller Option Code, Código de opción de impulsor

- Indicates L-Group pump (1780 RPM, 60 to 150 HP) • For 1180 RPM Close-Coupled applications only.
- Indica una bomba Grupo "L". (1780 RPM, de 60 a 150 HP) • Para aplicaciones de acople cerrado de 1180 RPM únicamente.

| Impeller Code, Código del impulsor | M-Group Pump Size, Tamaño de la bomba | | | | | | | | | | | |
|------------------------------------|---------------------------------------|---------|----------|----------|----------|----------|----------|---------|----------|----------|----------|--|
| | 8 | 7 | 11 | 13 | 16 | 12 | 14 | 10 | 17 | 15 | 21 | |
| | Dia. | Dia. | Dia. | Dia. | Dia. | Dia. | Dia. | Dia. | Dia. | Dia. | Dia. | |
| A | 10 1/16" | 7 1/16" | 10 1/16" | 13 1/16" | 8 1/16" | 10 1/16" | 13 1/16" | 7 7/8" | 10 1/16" | 12 3/8" | 10 1/16" | |
| B | 9 3/16" | 7 1/16" | 9 7/8" | 12 3/4" | 7 7/16" | 9 3/4" | 12 3/16" | 7 3/4" | 9 9/16" | 12 1/2" | 9 7/8" | |
| C | 8 3/8" | 7 3/16" | 9 5/8" | 11 7/8" | 7 1/16" | 9 | 12 3/16" | 7 1/2" | 9 7/8" | 12 1/4" | 9 1/2" | |
| D | 7 3/4" | 6 3/16" | 9 | 11 3/8" | 6 3/4" | 8 5/8" | 12 | 7 1/4" | 8 1/16" | 11 7/8" | 9 1/4" | |
| E | 7 1/4" | 6 3/8" | 8 3/8" | 9 7/8" | 6 3/8" | 8 1/8" | 11 3/4" | 7 | 8 1/8" | 11 3/8" | 8 5/16" | |
| F | 7 | 6 3/16" | 8 1/4" | 9 3/8" | 5 15/16" | 7 3/8" | 11 5/16" | 6 3/4" | 7 3/4" | 11 1/16" | 8 1/2" | |
| G | | | 8 | | 5 1/2" | *9 9/16" | 10 3/4" | 6 1/2" | | 10 7/8" | 8 3/16" | |
| H | | | 7 3/8" | | 5 1/8" | *8 3/4" | 10 1/8" | 6 1/16" | | 10 1/2" | 8 | |
| J | | | 7 1/8" | | 4 5/8" | *8 1/16" | 9 1/8" | 5 3/4" | | 10 1/4" | 7 11/16" | |
| K | | | | | | *8 1/8" | 8 11/16" | | | 9 1/8" | | |
| L | | | | | | *7 3/4" | 8 | | | 9 3/8" | | |
| M | | | | | | *7 5/8" | 7 9/16" | | | 13 1/16" | | |
| N | | | | | | *7 1/4" | | | | | | |
| P | | | | | | *7 1/16" | | | | | | |
| Q | | | | | | | | | | | | |
| R | | | | | | *6 3/4" | | | | | | |

| L-Group Pump Size, Tamaño de la bomba | | |
|---------------------------------------|-------------|------------|
| 18 | 19 | 20 |
| Dia. | Dia. | Dia. |
| ■ 13" | ■ 13" | ■ 16" |
| ■ 12 1/2" | ■ 12 3/4" | ■ 15 5/8" |
| ■ 12 1/8" | ■ 12 3/8" | ■ 15 1/16" |
| ■ 11 7/8" | ■ 11 5/16" | ■ 14 1/2" |
| 11 3/8" | ■ 11 1/16" | ■ 13 3/4" |
| 11 1/8" | ■ 11 1/4" | |
| 10 7/8" | ■ 10 7/8" | |
| 10 1/2" | ■ 9 13/16" | |
| 10 | • 13 | |
| 9 1/2" | • 12 3/4" | |
| • 13 | • 12 3/8" | |
| • 12 1/2" | • 11 5/16" | |
| • 12 3/16" | • 11 11/16" | |
| • 11 7/8" | • 11 1/4" | |
| | • 10 7/8" | |
| | • 9 13/16" | |

Driver, Elemento motor

- 1 = 1 PH, ODP 3 = 575 V, ODP 5 = 3 PH, TEFC 7 = 3 PH, XP 9 = 3 PH, TEFC, Premium efficiency
 2 = 3 PH, ODP 4 = 1 PH, TEFC 6 = 575 V, TEFC 8 = 575 V, XP Eficiencia superior
 1PH = monofásico, 3PH = trifásico 0 = 1 PH, XP

HP Rating, Potencia nominal, HP

- G = 2 J = 5 L = 10 N = 20 Q = 30 S = 50 U = 75 W = 125
 H = 3 K = 7 1/2 M = 15 P = 25 R = 40 T = 60 V = 100 X = 150

Driver: Hertz/Pole/RPM, Elemento motor: Hertz/Polos/RPM

- 1 = 60 Hz, 2 pole, 3500 RPM 3 = 60 Hz, 6 pole, 1180 RPM 5 = 50 Hz, 4 pole, 1450 RPM
 2 = 60 Hz, 4 pole, 1750 RPM 4 = 50 Hz, 2 pole, 2900 RPM

Material (Packed Box in AI or BF), Material (Caja prensaestopas en AI o BF)

- AI = All iron BF = Bronze fitted AI = Todo hierro BF = con accesorios de bronce

Pump Size, Tamaño de bomba

- 8 = 1 1/2 x 2 - 10 11 = 2 1/2 x 3 - 10 12 = 3 x 4 - 10 10 = 4 x 5 - 8 16 = 3 x 4 - 8

- 18 = 6 x 8 - 13 19 = 8 x 10 - 13 20 = 4 x 6 - 16 21 = 2 1/2 x 3 - 9

- 7 = 2 1/2 x 3 - 8 13 = 2 1/2 x 3 - 13 14 = 3 x 4 - 13 15 = 4 x 6 - 13 17 = 4 x 6 - 10 (BF Only) (Accesorios de bronce únicamente)

* Indicates 3500 RPM impeller for the 3 x 4 - 10, all others are 1750 RPM.

* Indica un impulsor de 3500 RPM para el 3 x 4 - 10, todos los demás son de 1750 RPM.

Drive Options, Opciones de mando

| Substitute, Substituto | Description, Descripción |
|------------------------|--|
| FRM | Bearing frame mount, Montaje del bastidor del cojinete |
| SAE1 | SAE #1 mount, Montura SAE #1 |
| SAE2 | SAE #2 mount, Montura SAE #2 |
| | SAE #3 mount, Montura SAE #3 |
| SAE4 | SAE #4 mount, Montura SAE #4 |
| | SAE #5 mount, Montura SAE #5 |

SAE drive number is determined by the engine flywheel housing size.

El número del mando SAE se determina por el tamaño de la caja del volante del motor.

Performance Curves – 60 Hz, 3500 RPM Curvas de desempeño – 60 Hz, 3500 RPM

These curves show the performance of the 3656 and 3756 at 3500 RPM and 1750 RPM, 60 Hz, and at 2900 RPM and 1450 RPM, 50 Hz. Standard impeller trims are shown. Note that not all pump sizes are available at the higher speeds.

Estas curvas ilustran el desempeño de los modelos 3656 y 3756 operando a 3500 RPM y 1750 RPM en 60 Hz, y a 2900 RPM y 1450 RPM en 50 Hz. Se muestran los diámetros de impulsor estándar. Se ha de notar que no todos los tamaños de bomba están disponibles en altas velocidades.

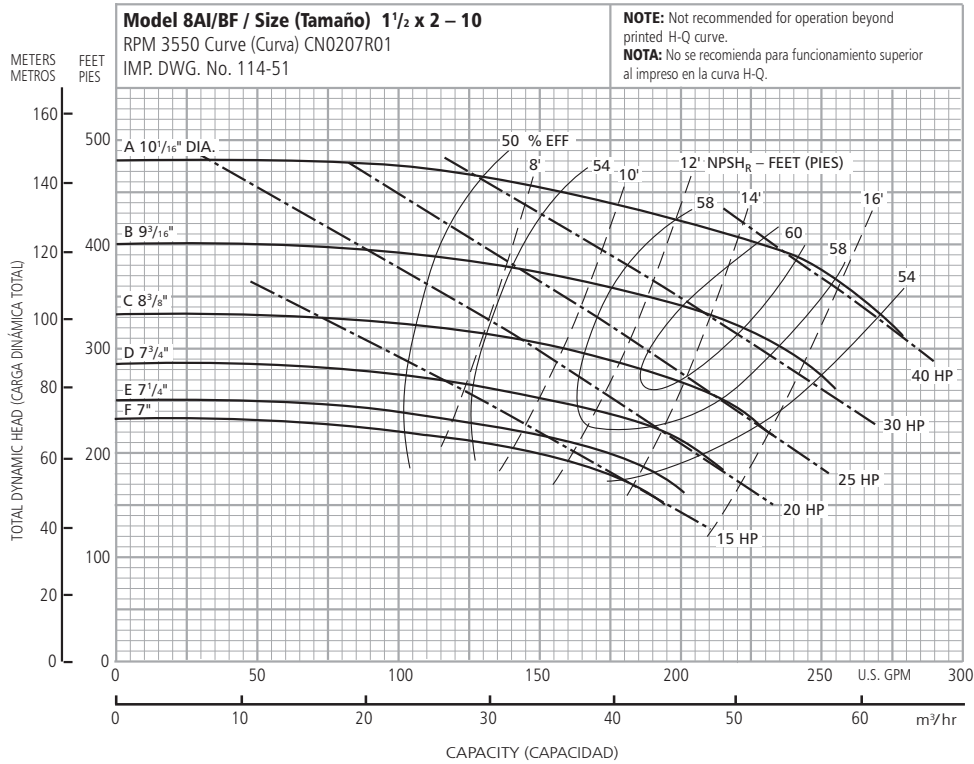

| Optional Impeller Impulsor optativo | |
|--|--------------|
| Ordering Code Código de pedido | Dia. Diá. |
| A | 10 1/16" |
| B | 9 3/16" |
| C | 8 3/8" |
| D | 7 3/4" |
| E | 7 1/4" |
| F | 7" |

NOTE: Pump will pass a sphere to 5/32" diameter.

NOTA: La bomba dejará pasar una esfera de hasta 5/32 de pulgada de diámetro.

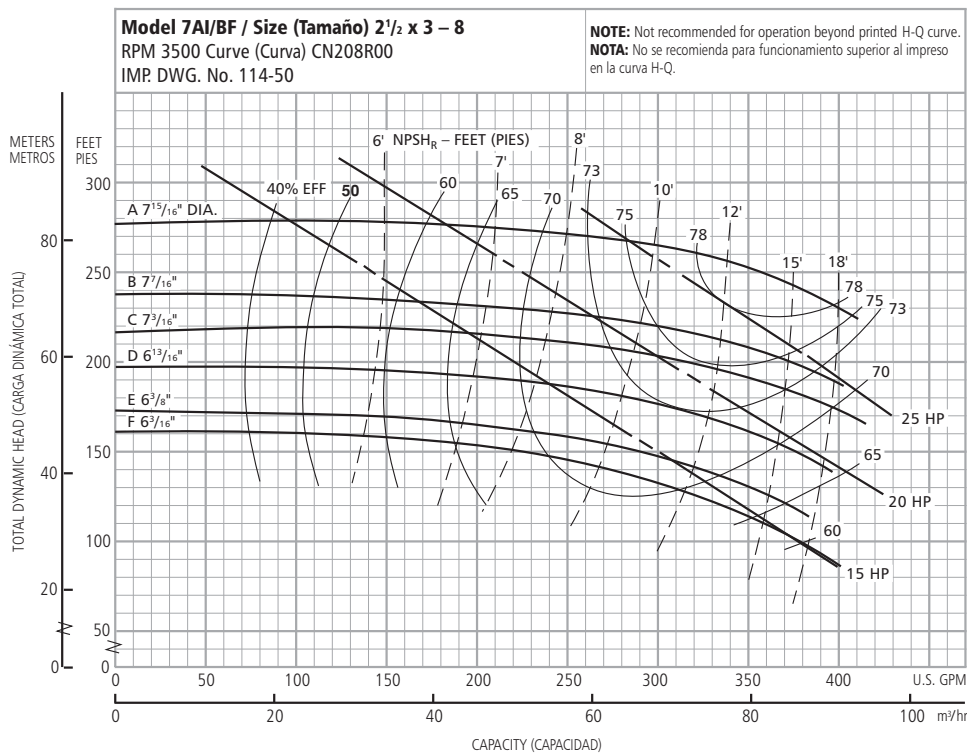

| Optional Impeller Impulsor optativo | |
|--|--------------|
| Ordering Code Código de pedido | Dia. Diá. |
| A | 7 15/16" |
| B | 7 1/16" |
| C | 7 3/16" |
| D | 6 13/16" |
| E | 6 3/8" |
| F | 6 3/16" |

NOTE: Pump will pass a sphere to 5/16" diameter.

NOTA: La bomba dejará pasar una esfera de hasta 5/16 de pulgada de diámetro.

Performance Curves – 60 Hz, 3500 RPM
Curvas de desempeño – 60 Hz, 3500 RPM

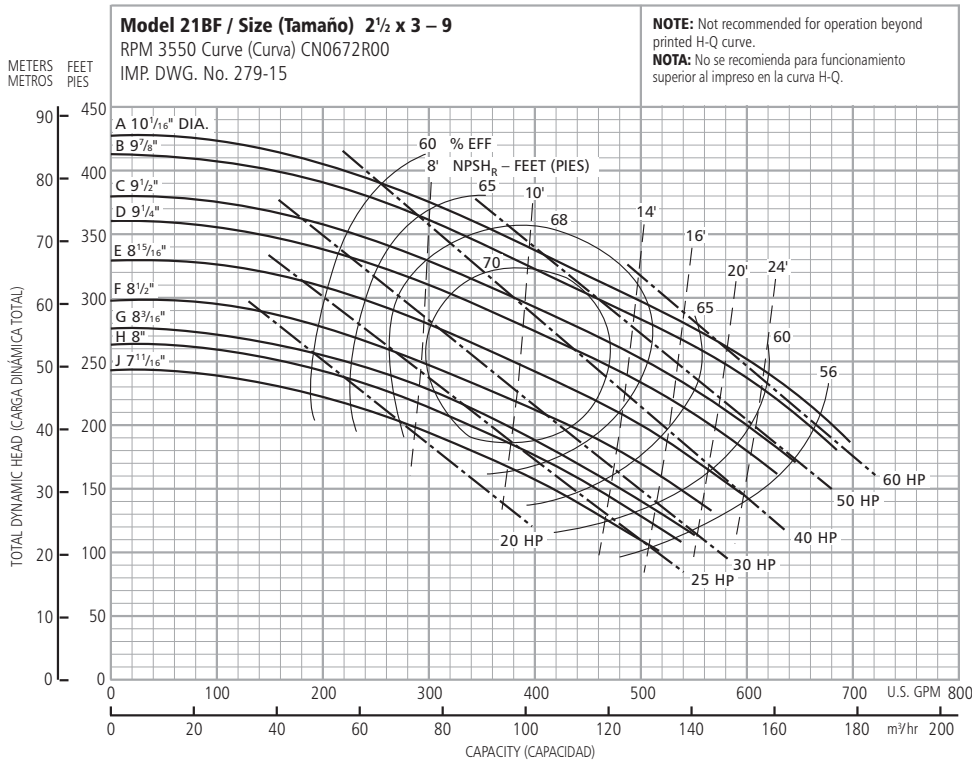

| Optional Impeller Impulsor optativo | |
|--|-----------------------------------|
| Ordering Code Código de pedido | Dia. Diá. |
| A | 10 ¹ / ₁₆ " |
| B | 9 ⁷ / ₈ |
| C | 9 ¹ / ₂ |
| D | 9 ¹ / ₄ |
| E | 8 ¹⁵ / ₁₆ |
| F | 8 ¹ / ₂ |
| G | 8 ³ / ₁₆ |
| H | 8 |
| J | 7 ¹¹ / ₁₆ |

NOTE: Pump will pass a sphere to ⁵/₁₆" diameter.
NOTA: La bomba dejará pasar una esfera de hasta ⁵/₁₆ de pulgada de diámetro.

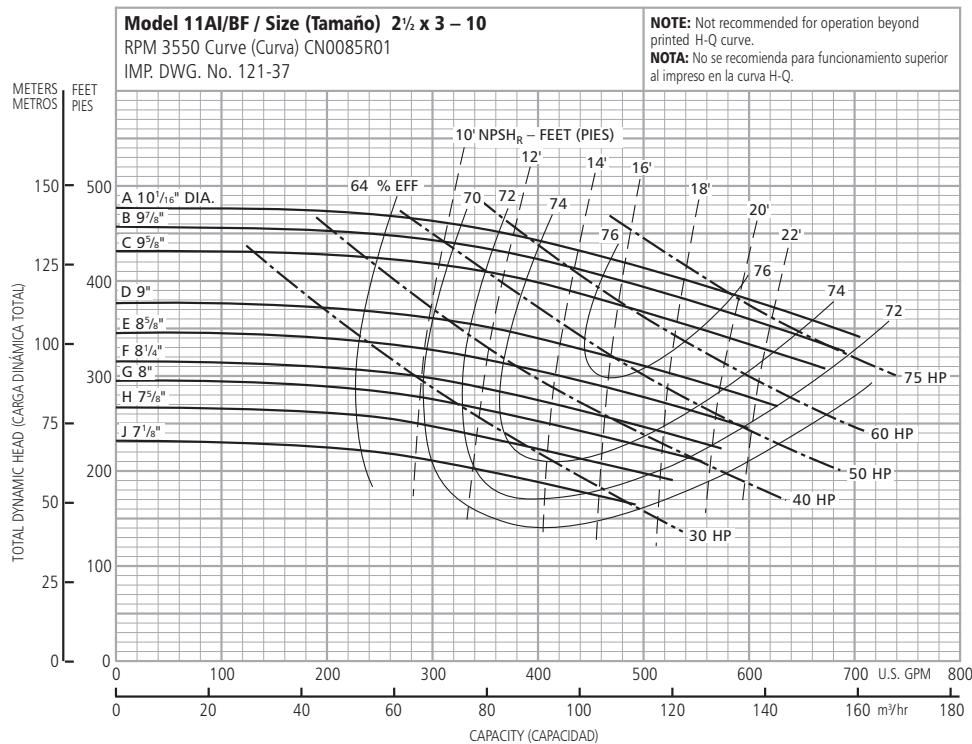

| Optional Impeller Impulsor optativo | |
|--|-----------------------------------|
| Ordering Code Código de pedido | Dia. Diá. |
| A | 10 ¹ / ₁₆ " |
| B | 9 ⁷ / ₈ |
| C | 9 ⁵ / ₈ |
| D | 9 |
| E | 8 ⁵ / ₈ |
| F | 8 ¹ / ₄ |
| G | 8 |
| H | 7 ⁵ / ₈ |
| J | 7 ¹ / ₈ |

NOTE: Pump will pass a sphere to ⁵/₁₆" diameter.
NOTA: La bomba dejará pasar una esfera de hasta ⁵/₁₆ de pulgada de diámetro.

Performance Curves – 60 Hz, 3500 RPM

Curvas de desempeño – 60 Hz, 3500 RPM

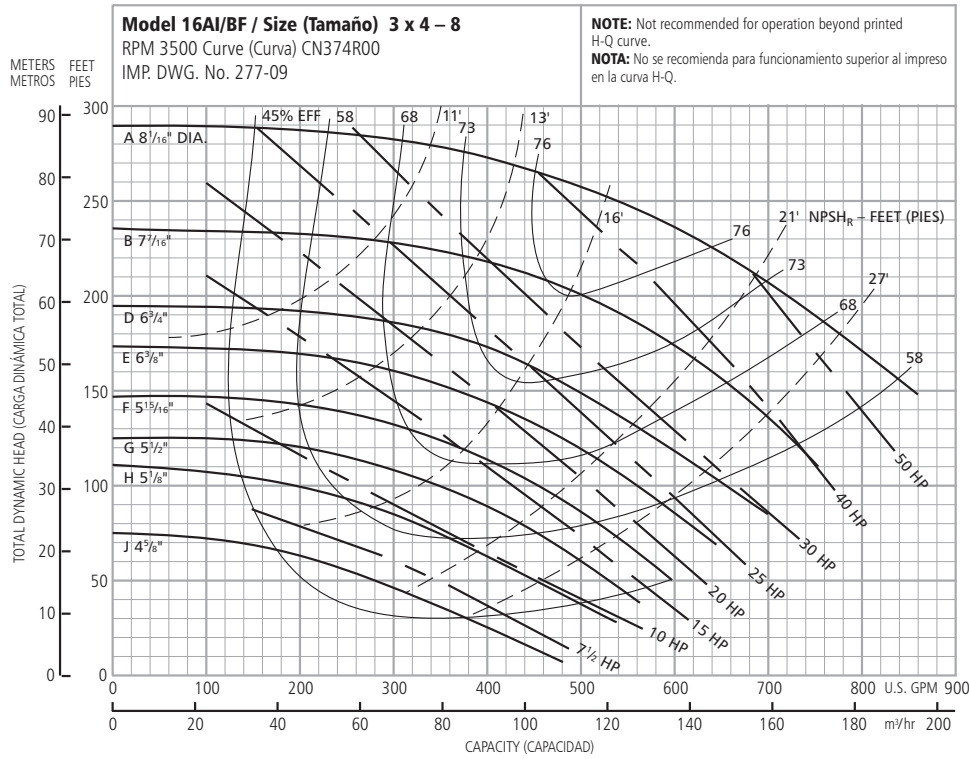

| Optional Impeller Impulsor optativo | |
|--|--------------|
| Ordering Code Código de pedido | Dia. Diá. |
| A | 8 1/16" |
| B | 7 7/16" |
| D | 6 3/4" |
| E | 6 3/8" |
| F | 5 15/16" |
| G | 5 1/2" |
| H | 5 1/8" |
| J | 4 7/8" |

NOTE: Pump will pass a sphere to 3/8" diameter.
NOTA: La bomba dejará pasar una esfera de hasta 3/8 de pulgada de diámetro.

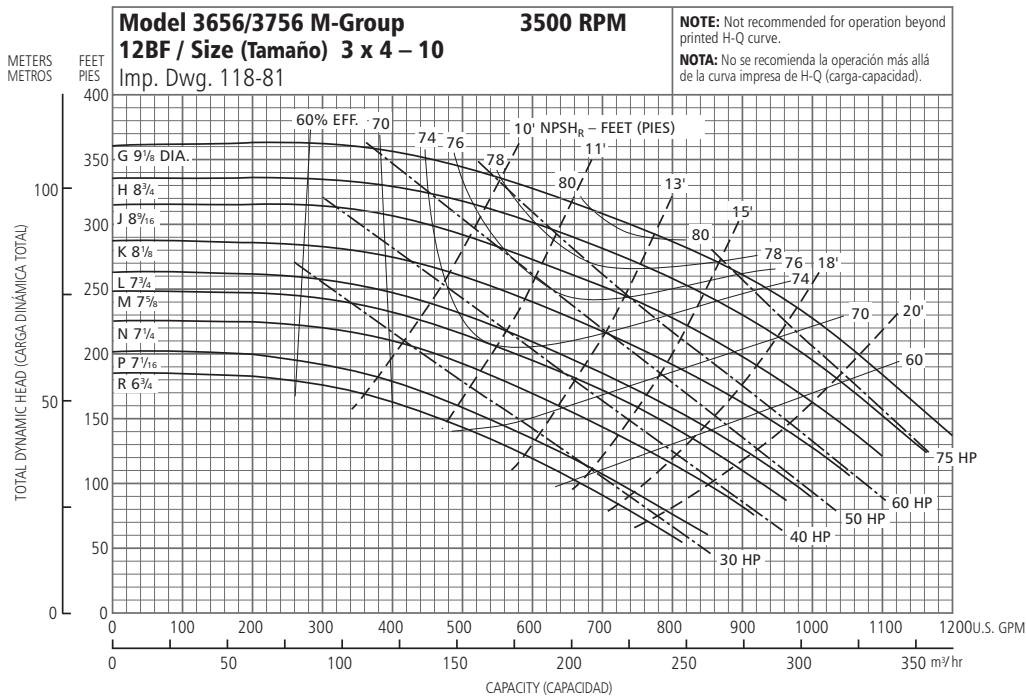

| Optional Impeller Impulsor optativo | |
|--|--------------|
| Ordering Code Código de pedido | Dia. Diá. |
| G | 9 1/8" |
| H | 8 3/4" |
| J | 8 9/16" |
| K | 8 1/8" |
| L | 7 3/4" |
| M | 7 5/8" |
| N | 7 1/4" |
| P | 7 1/16" |
| R | 6 3/4" |

NOTE: Pump will pass a sphere to 1/2" diameter.
NOTA: La bomba dejará pasar una esfera de hasta 1/2 de pulgada de diámetro.

Performance Curves – 60 Hz, 3500 RPM
Curvas de desempeño – 60 Hz, 3500 RPM

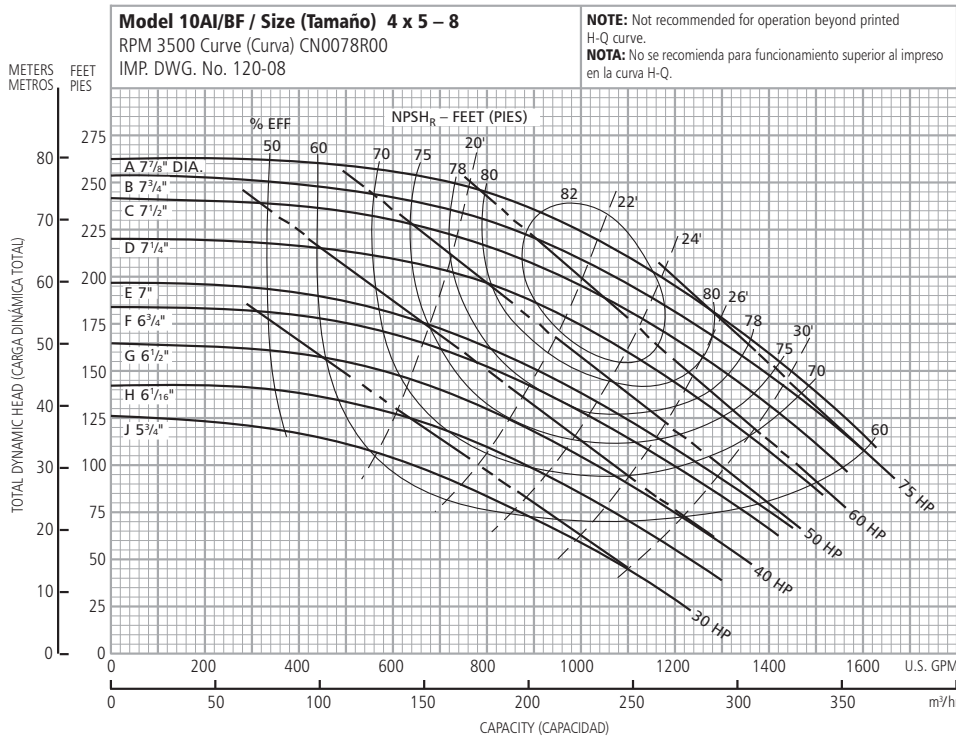

| Optional Impeller Impulsor optativo | |
|--|--------------|
| Ordering Code Código de pedido | Dia. Diá. |
| A | 7 7/8" |
| B | 7 3/4" |
| C | 7 1/2" |
| D | 7 1/4" |
| E | 7" |
| F | 6 3/4" |
| G | 6 1/2" |
| H | 6 1/16" |
| J | 5 3/4" |

NOTE: Pump will pass a sphere to 5/16" diameter.
NOTA: La bomba dejará pasar una esfera de hasta 5/16 de pulgada de diámetro.

Performance Curves – 60 Hz, 1750 RPM
Curvas de desempeño – 60 Hz, 1750 RPM

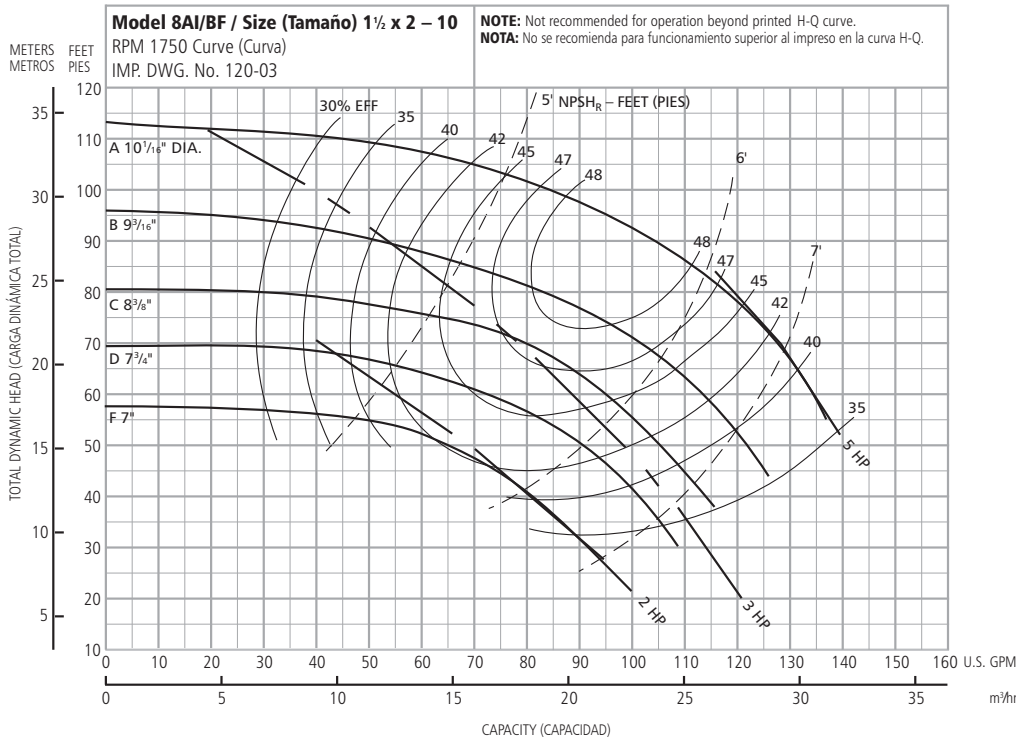

| Optional Impeller Impulsor optativo | |
|--|--------------|
| Ordering Code Código de pedido | Dia. Diá. |
| A | 10 1/16" |
| B | 9 3/16" |
| C | 8 3/8" |
| D | 7 3/4" |
| F | 7" |

NOTE: Pump will pass a sphere to 5/32" diameter.
NOTA: La bomba dejará pasar una esfera de hasta 5/32 de pulgada de diámetro.

Performance Curves – 60 Hz, 1750 RPM
Curvas de desempeño – 60 Hz, 1750 RPM

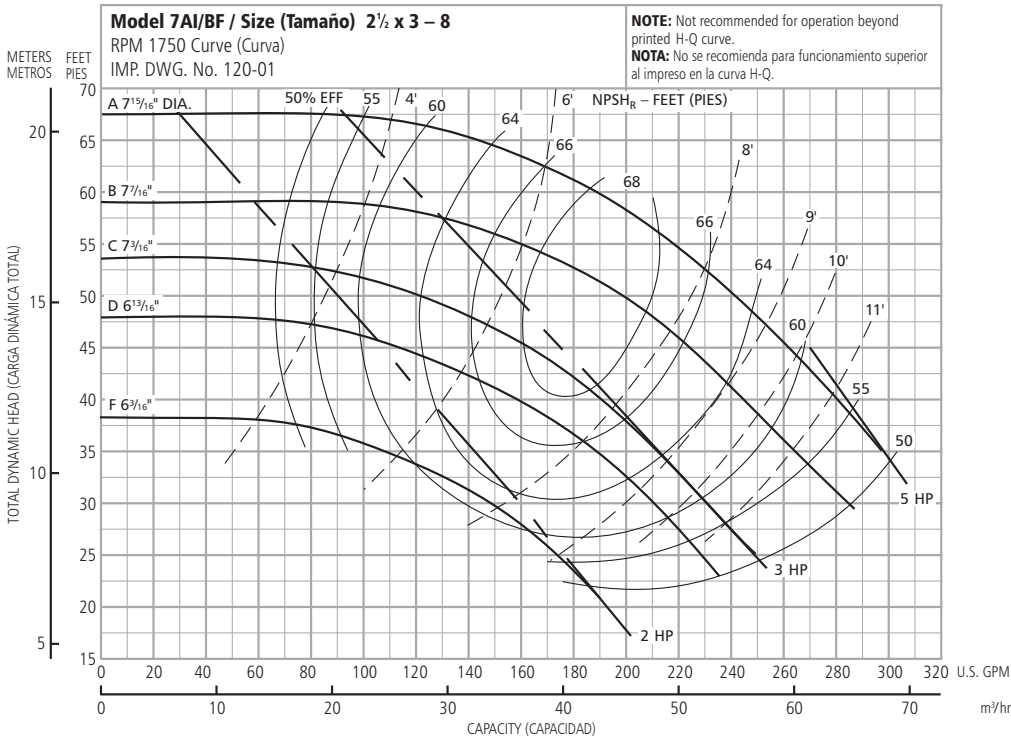

Optional Impeller
Impulsor optativo

| Ordering Code Código de pedido | Dia. Diá. |
|-----------------------------------|----------------------------------|
| A | 7 ¹ / ₁₆ " |
| B | 7 ⁷ / ₁₆ " |
| C | 7 ³ / ₁₆ " |
| D | 6 ³ / ₁₆ " |
| F | 6 ³ / ₁₆ " |

NOTE: Pump will pass a sphere to 5/16" diameter.
NOTA: La bomba dejará pasar una esfera de hasta 5/16 de pulgada de diámetro.

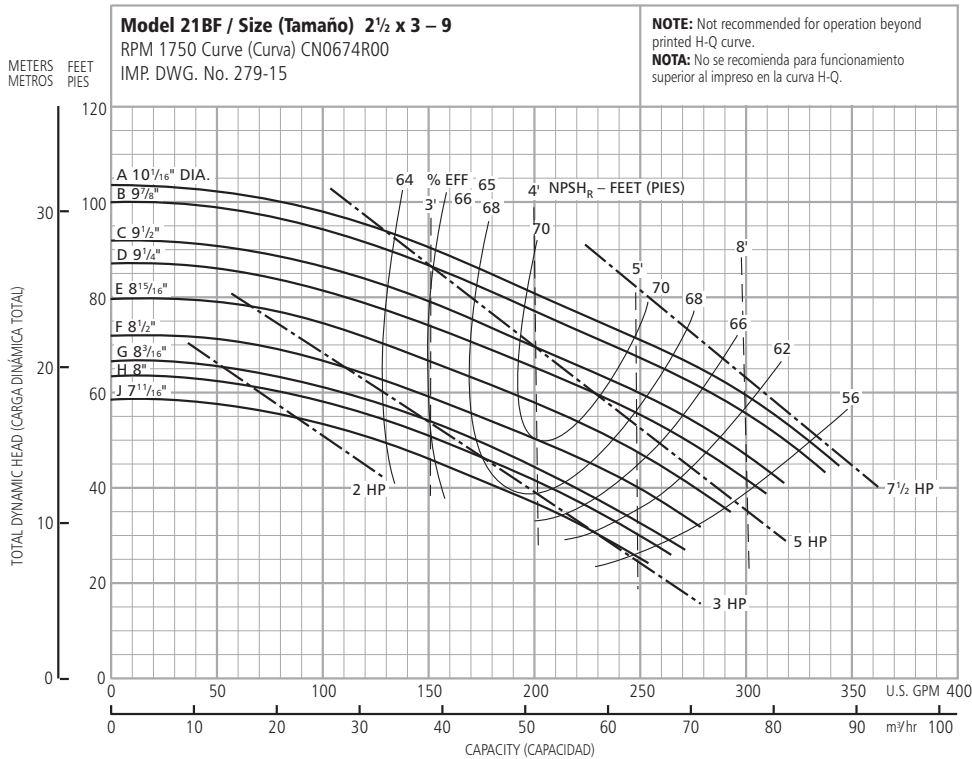

Optional Impeller
Impulsor optativo

| Ordering Code Código de pedido | Dia. Diá. |
|-----------------------------------|-----------------------------------|
| A | 10 ¹ / ₁₆ " |
| B | 9 ⁷ / ₈ " |
| C | 9 ¹ / ₂ " |
| D | 9 ¹ / ₄ " |
| E | 8 ¹⁵ / ₁₆ " |
| F | 8 ¹ / ₂ " |
| G | 8 ³ / ₁₆ " |
| H | 8 |
| J | 7 ¹ / ₁₆ " |

NOTE: Pump will pass a sphere to 5/16" diameter.
NOTA: La bomba dejará pasar una esfera de hasta 5/16 de pulgada de diámetro.

Performance Curves – 60 Hz, 1750 RPM
Curvas de desempeño – 60 Hz, 1750 RPM

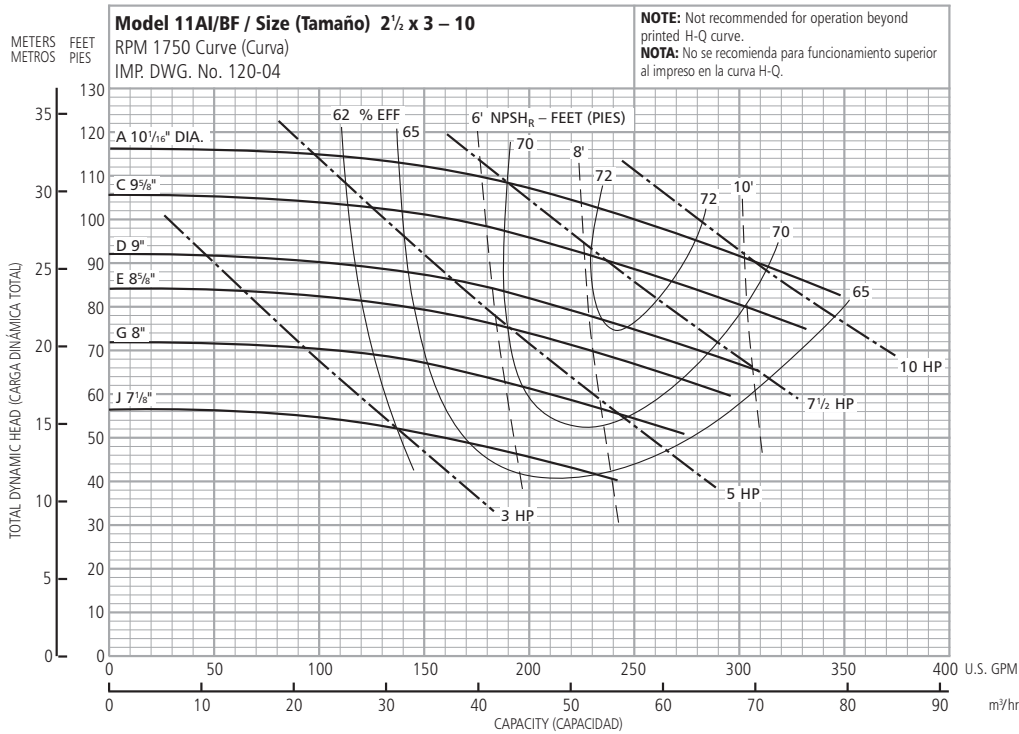

| Optional Impeller Impulsor optativo | |
|--|--------------|
| Ordering Code Código de pedido | Dia. Diá. |
| A | 10½" |
| C | 9⅝" |
| D | 9" |
| E | 8⅝" |
| G | 8" |
| J | 7⅝" |

NOTE: Pump will pass a sphere to 5/16" diameter.
NOTA: La bomba dejará pasar una esfera de hasta 5/16 de pulgada de diámetro.

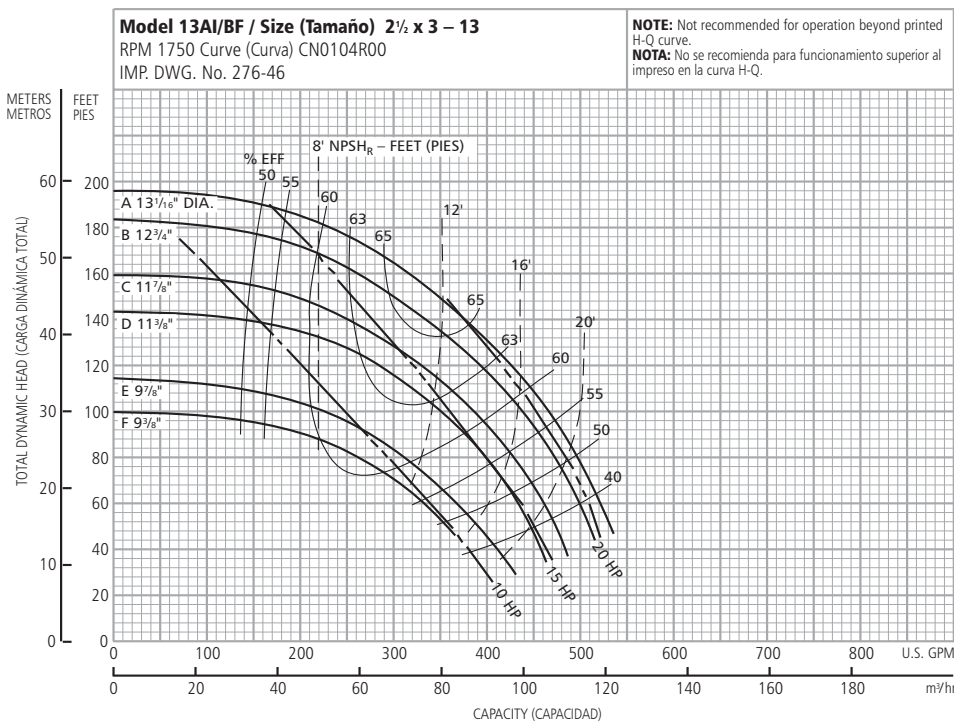

| Optional Impeller Impulsor optativo | |
|--|--------------|
| Ordering Code Código de pedido | Dia. Diá. |
| A | 13½" |
| B | 12¾" |
| C | 11⅞" |
| D | 11⅜" |
| E | 9⅞" |
| F | 9⅝" |

NOTE: Pump will pass a sphere to 5/16" diameter.
NOTA: La bomba dejará pasar una esfera de hasta 5/16 de pulgada de diámetro.

Performance Curves – 60 Hz, 1750 RPM
Curvas de desempeño – 60 Hz, 1750 RPM

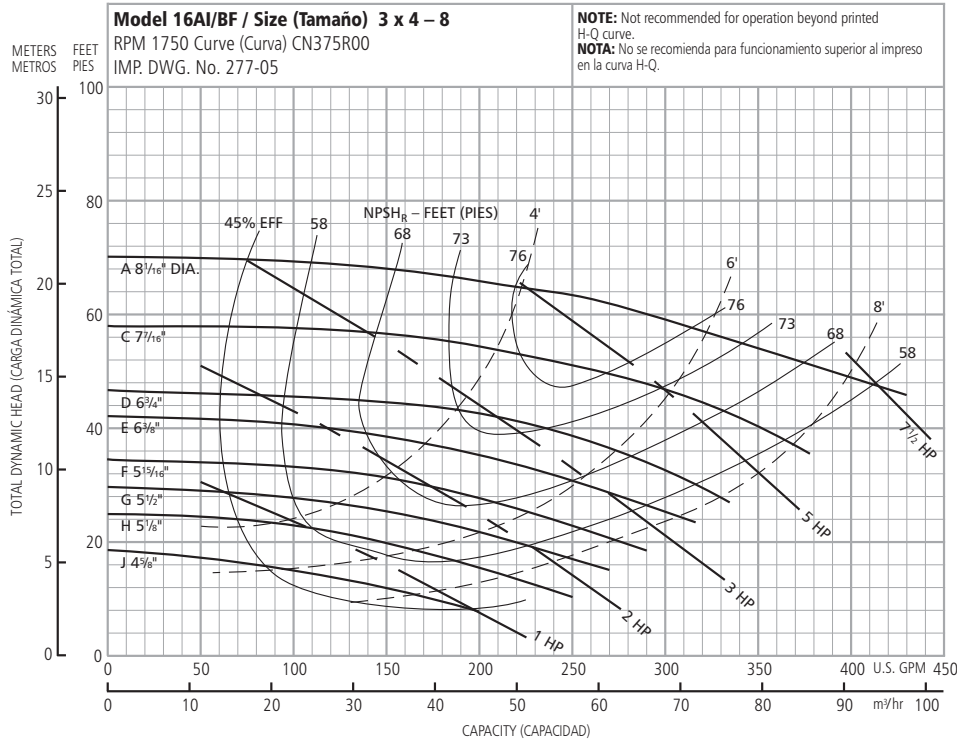

| Optional Impeller Impulsor optativo | |
|--|--------------|
| Ordering Code Código de pedido | Dia. Diá. |
| A | 8 1/16" |
| C | 7 7/16 |
| D | 6 3/4 |
| E | 6 3/8 |
| F | 5 15/16 |
| G | 5 1/2 |
| H | 5 1/8 |
| J | 4 5/8 |

NOTE: Pump will pass a sphere to 3/8" diameter.
NOTA: La bomba dejará pasar una esfera de hasta 3/8 de pulgada de diámetro.

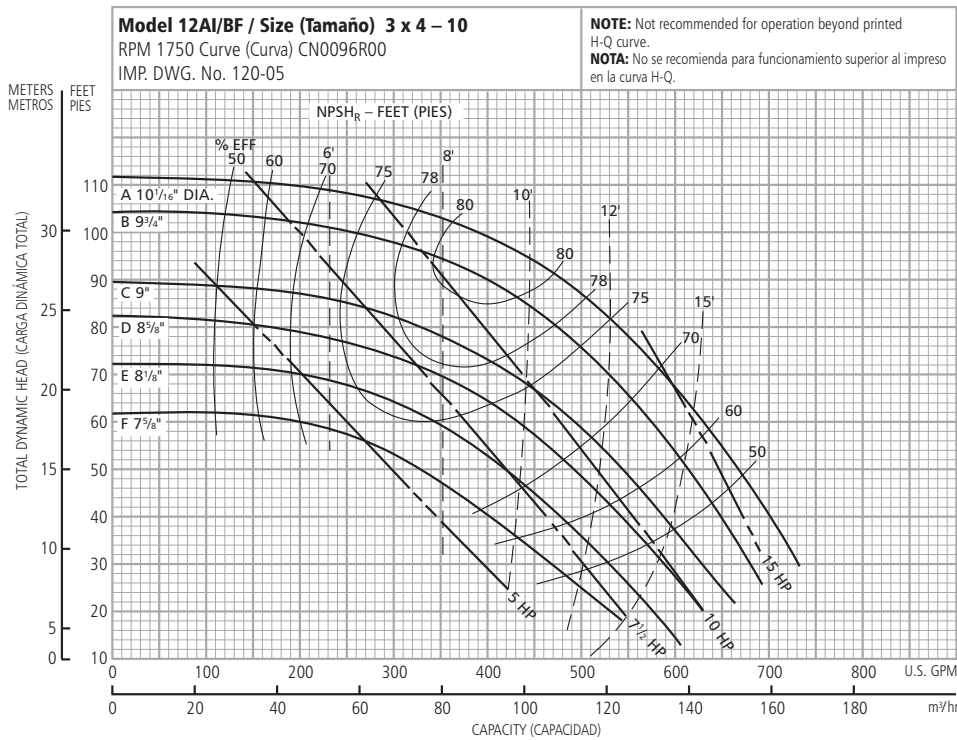

| Optional Impeller Impulsor optativo | |
|--|--------------|
| Ordering Code Código de pedido | Dia. Diá. |
| A | 10 1/16" |
| B | 9 3/4 |
| C | 9 |
| D | 8 5/8 |
| E | 8 1/8 |
| F | 7 5/8 |

NOTE: Pump will pass a sphere to 3/8" diameter.
NOTA: La bomba dejará pasar una esfera de hasta 3/8 de pulgada de diámetro.

Performance Curves – 60 Hz, 1750 RPM
Curvas de desempeño – 60 Hz, 1750 RPM

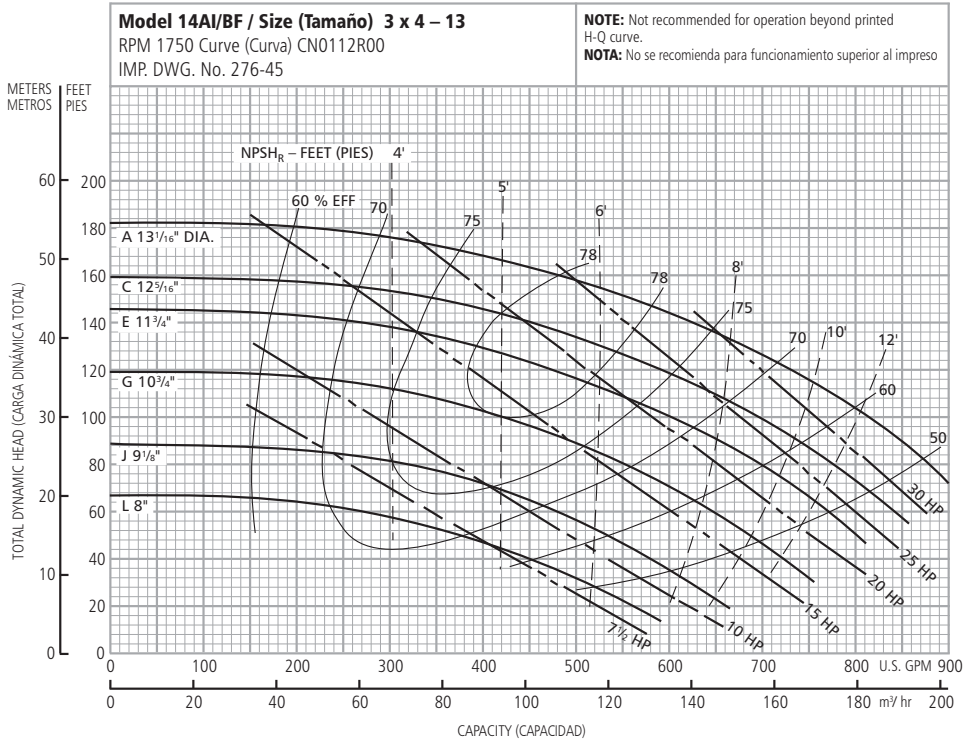

| Optional Impeller Impulsor optativo | |
|--|--------------|
| Ordering Code Código de pedido | Dia. Diá. |
| A | 13 1/16" |
| C | 12 5/16" |
| E | 11 3/4" |
| G | 10 3/4" |
| J | 9 1/8" |
| L | 8" |

NOTE: Pump will pass a sphere to 3/8" diameter.
NOTA: La bomba dejará pasar una esfera de hasta 3/8 de pulgada de diámetro.

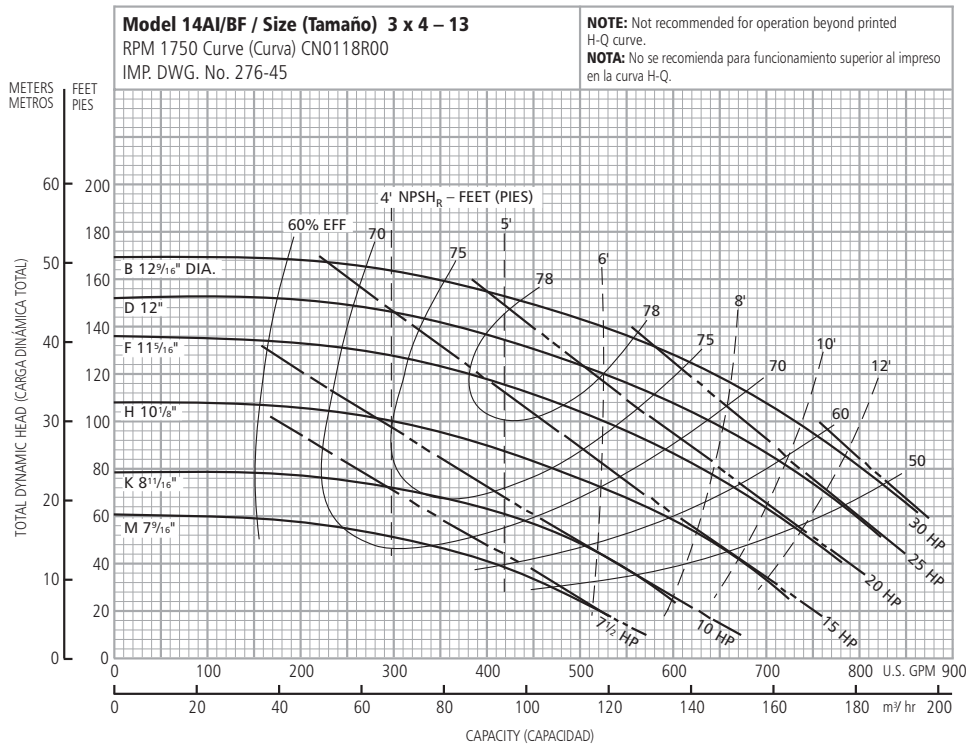

| Optional Impeller Impulsor optativo | |
|--|--------------|
| Ordering Code Código de pedido | Dia. Diá. |
| B | 12 9/16" |
| D | 12" |
| F | 11 5/16" |
| H | 10 1/8" |
| K | 8 1/16" |
| M | 7 9/16" |

NOTE: Pump will pass a sphere to 3/8" diameter.
NOTA: La bomba dejará pasar una esfera de hasta 3/8 de pulgada de diámetro.

Performance Curves – 60 Hz, 1750 RPM
Curvas de desempeño – 60 Hz, 1750 RPM

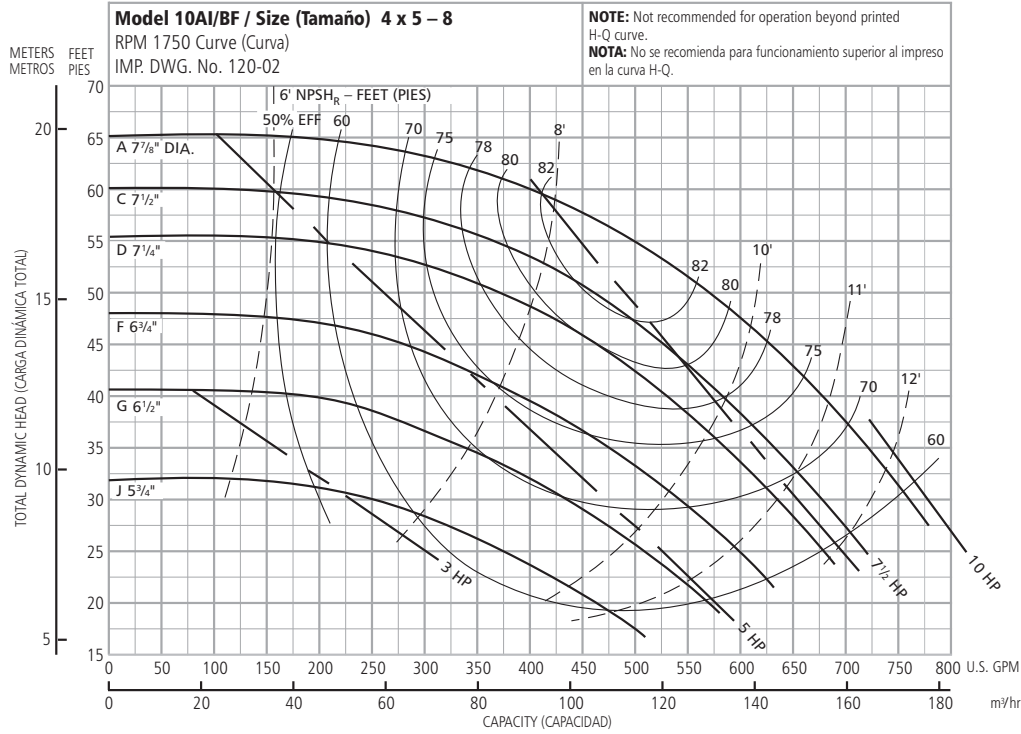

| Optional Impeller Impulsor optativo | |
|--|----------------------------------|
| Ordering Code Código de pedido | Dia. Diá. |
| A | 7 ⁷ / ₁₆ " |
| C | 7 ¹ / ₂ " |
| D | 7 ¹ / ₄ " |
| F | 6 ³ / ₄ " |
| G | 6 ¹ / ₂ " |
| J | 5 ³ / ₄ " |

NOTE: Pump will pass a sphere to 5³/₁₆" diameter.
NOTA: La bomba dejará pasar una esfera de hasta 5³/₁₆" de pulgada de diámetro.

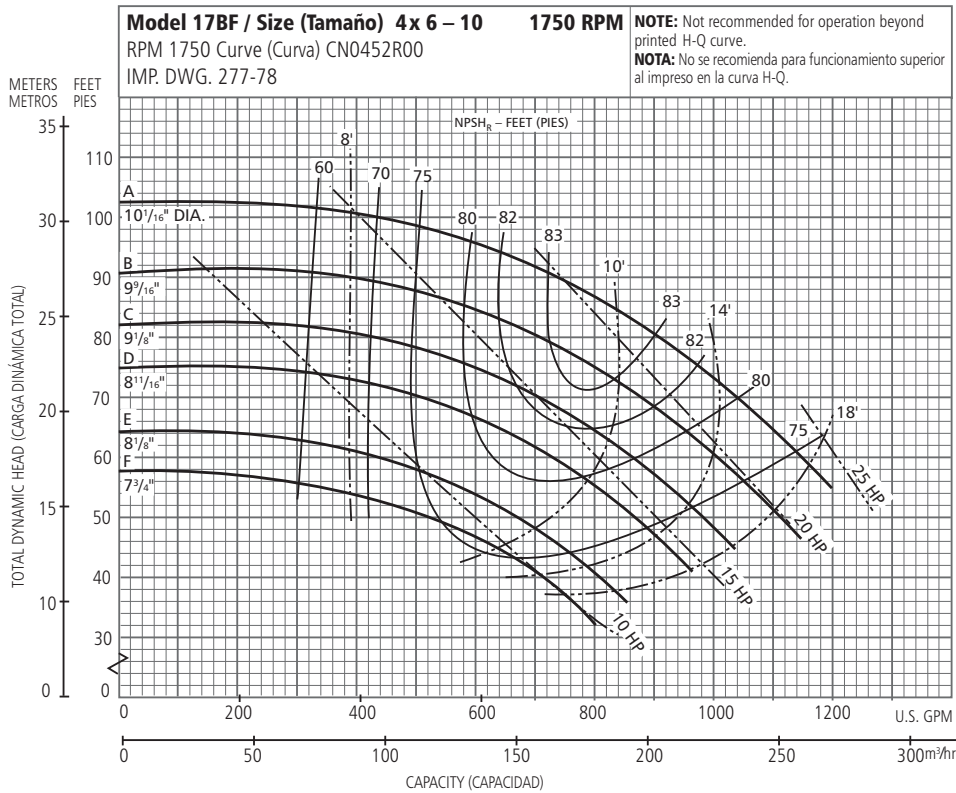

| Optional Impeller Impulsor optativo | |
|--|-----------------------------------|
| Ordering Code Código de pedido | Dia. Diá. |
| A | 10 ¹ / ₁₆ " |
| B | 9 ⁹ / ₁₆ " |
| C | 9 ¹ / ₈ " |
| D | 8 ¹¹ / ₁₆ " |
| E | 8 ¹ / ₈ " |
| F | 7 ³ / ₄ " |

NOTE: Pump will pass a sphere to 7¹/₁₆" diameter.
NOTA: La bomba dejará pasar una esfera de hasta 7¹/₁₆" de pulgada de diámetro.

Performance Curves – 60 Hz, 1750 RPM
Curvas de desempeño – 60 Hz, 1750 RPM

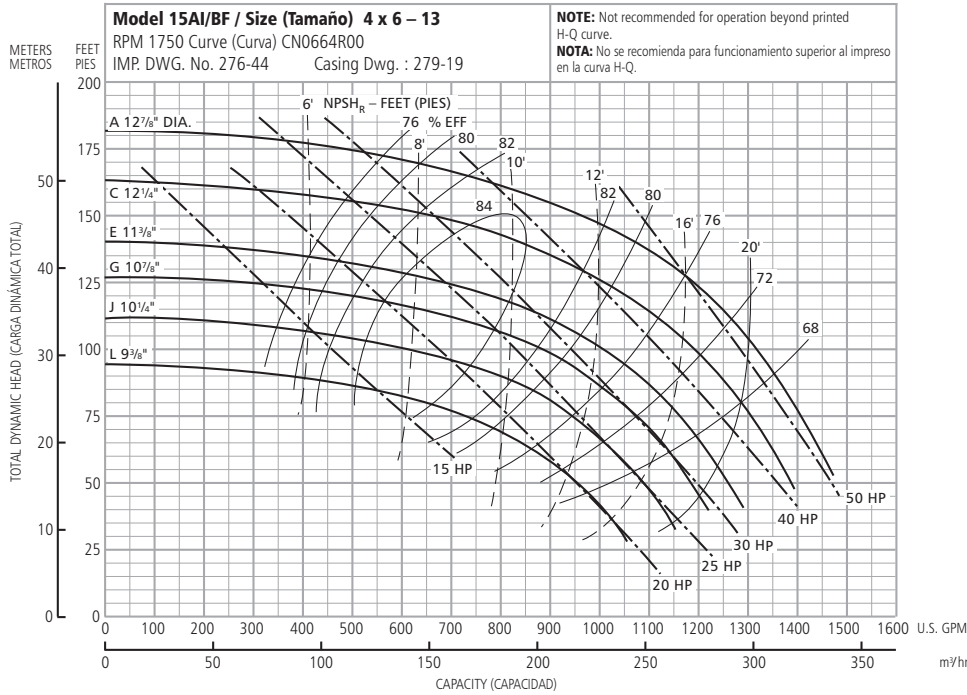

| Optional Impeller Impulsor optativo | |
|--|--------------|
| Ordering Code Código de pedido | Dia. Diá. |
| A | 12 7/8" |
| C | 12 1/4" |
| E | 11 3/8" |
| G | 10 7/8" |
| J | 10 1/4" |
| L | 9 3/8" |

NOTE: Pump will pass a sphere to 7/16" diameter.
NOTA: La bomba dejará pasar una esfera de hasta 7/16 de pulgada de diámetro.

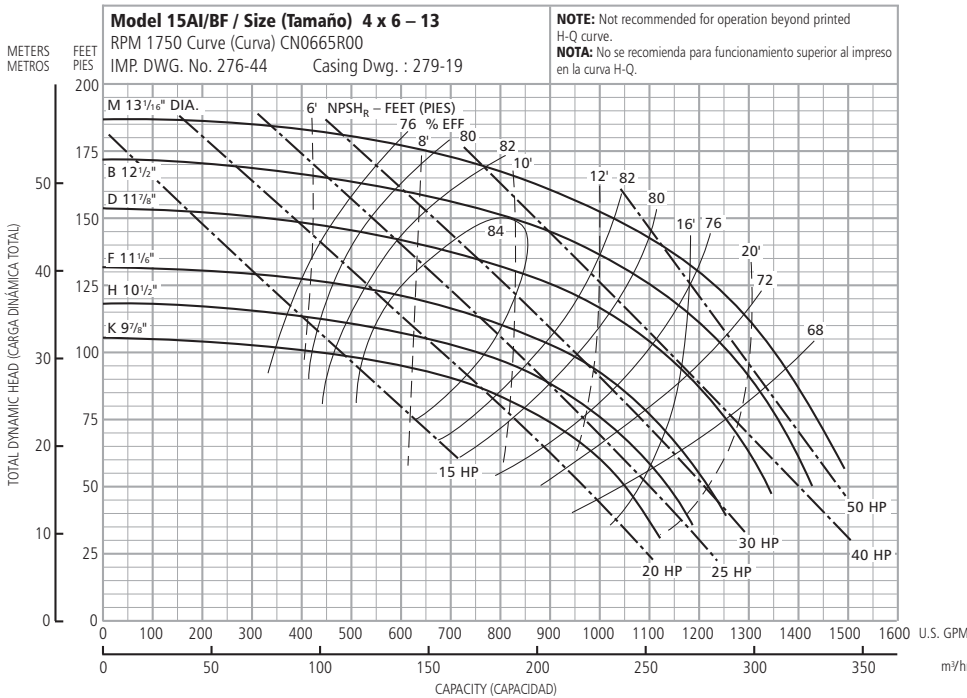

| Optional Impeller Impulsor optativo | |
|--|--------------|
| Ordering Code Código de pedido | Dia. Diá. |
| M | 13 1/8" |
| B | 12 1/2" |
| D | 11 7/8" |
| F | 11 1/8" |
| H | 10 1/2" |
| K | 9 7/8" |

NOTE: Pump will pass a sphere to 7/16" diameter.
NOTA: La bomba dejará pasar una esfera de hasta 7/16 de pulgada de diámetro.

Performance Curves – 60 Hz, 1780 RPM
Curvas de desempeño – 60 Hz, 1780 RPM

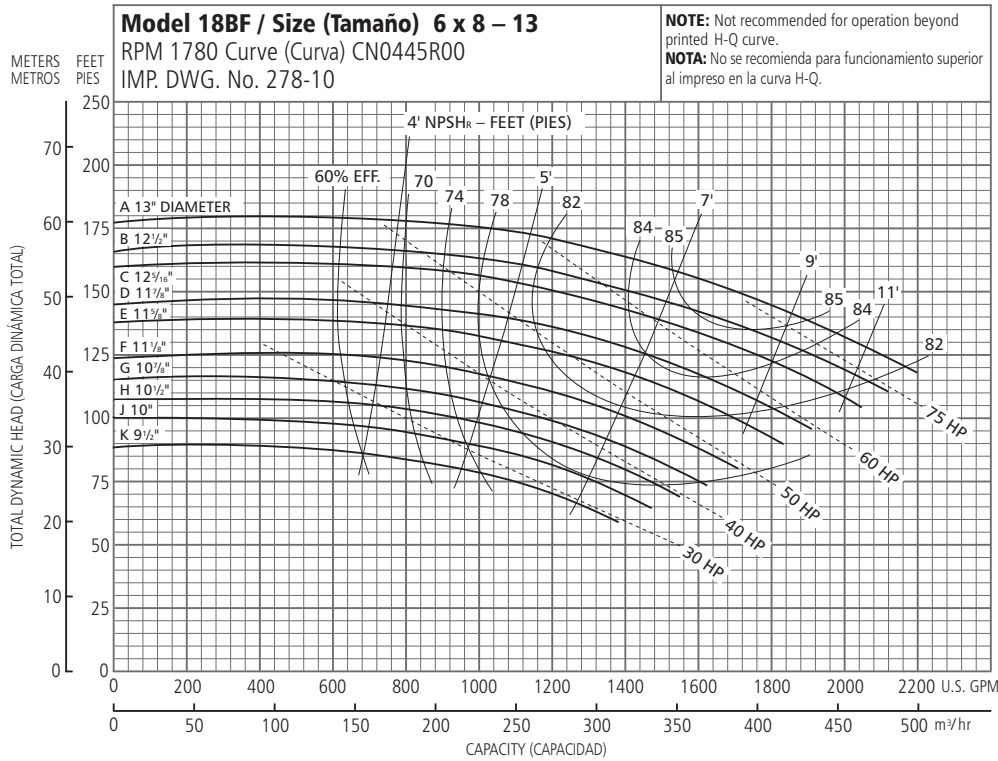

| Optional Impeller Impulsor optativo | |
|--|--------------|
| Ordering Code Código de pedido | Dia. Diá. |
| ■ A | 13" |
| ■ B | 12 1/2" |
| ■ C | 12 5/16" |
| ■ D | 11 7/8" |
| ■ E | 11 5/8" |
| ■ F | 11 1/8" |
| ■ G | 10 7/8" |
| ■ H | 10 1/2" |
| ■ J | 10" |
| ■ K | 9 1/2" |

NOTE: Pump will pass a sphere to 7/8" diameter.

NOTA: La bomba dejará pasar una esfera de hasta 7/8 de pulgada de diámetro.

■ Indicates "L" Group pump.

■ Indica una bomba Grupo "L".

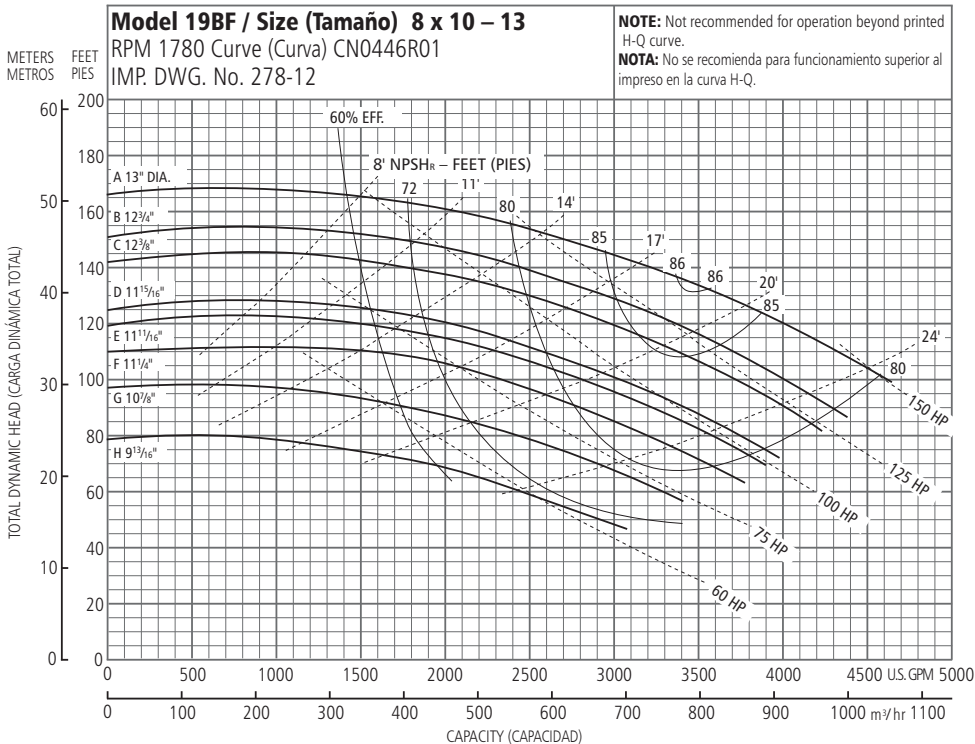

| Optional Impeller Impulsor optativo | |
|--|--------------|
| Ordering Code Código de pedido | Dia. Diá. |
| ■ A | 13" |
| ■ B | 12 3/4" |
| ■ C | 12 3/8" |
| ■ D | 11 15/16" |
| ■ E | 11 11/16" |
| ■ F | 11 1/4" |
| ■ G | 10 7/8" |
| ■ H | 9 13/16" |

NOTE: Pump will pass a sphere to 7/8" diameter.

NOTA: La bomba dejará pasar una esfera de hasta 7/8 de pulgada de diámetro.

■ Indicates "L" Group pump.

■ Indica una bomba Grupo "L".

Performance Curves – 60 Hz, 1780 RPM
Curvas de desempeño – 60 Hz, 1780 RPM

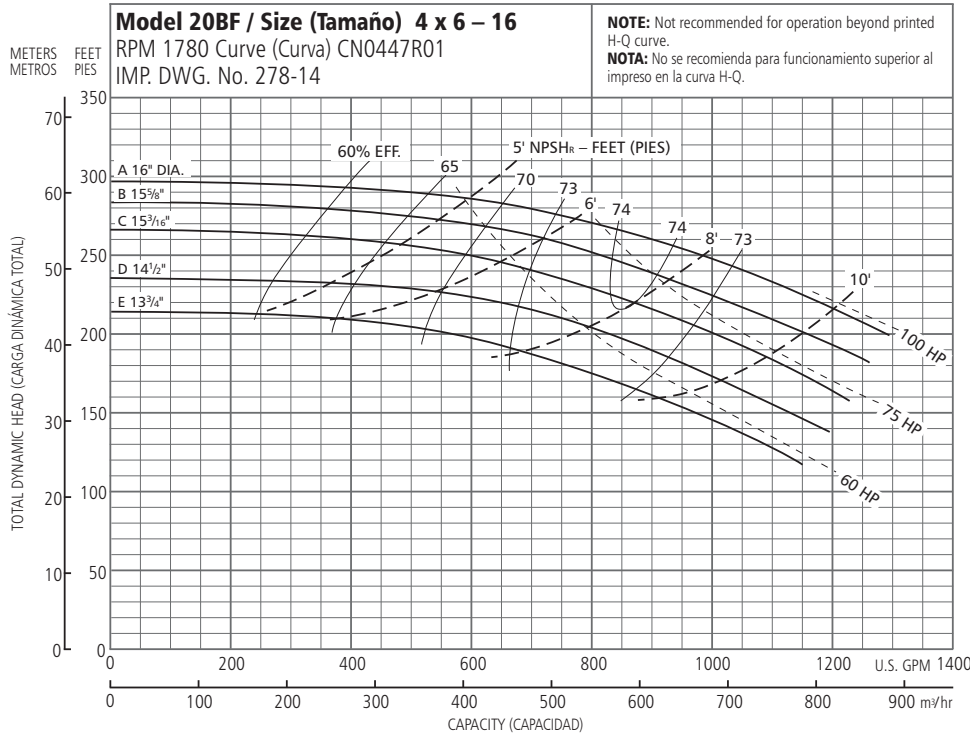

| Optional Impeller Impulsor optativo | |
|--|---------------------------------|
| Ordering Code Código de pedido | Dia. Diá. |
| ■ A | 16" |
| ■ B | 15 ⁵ / ₈ |
| ■ C | 15 ³ / ₁₆ |
| ■ D | 14 ¹ / ₂ |
| ■ E | 3 ³ / ₄ |

NOTE: Pump will pass a sphere to 5/8" diameter.
NOTA: La bomba dejará pasar una esfera de hasta 5/8 de pulgada de diámetro.

■ Indicates "L" Group pump.
 ■ Indica una bomba Grupo "L".

Performance Curves – 60 Hz, 1180 RPM
Curvas de desempeño – 60 Hz, 1180 RPM

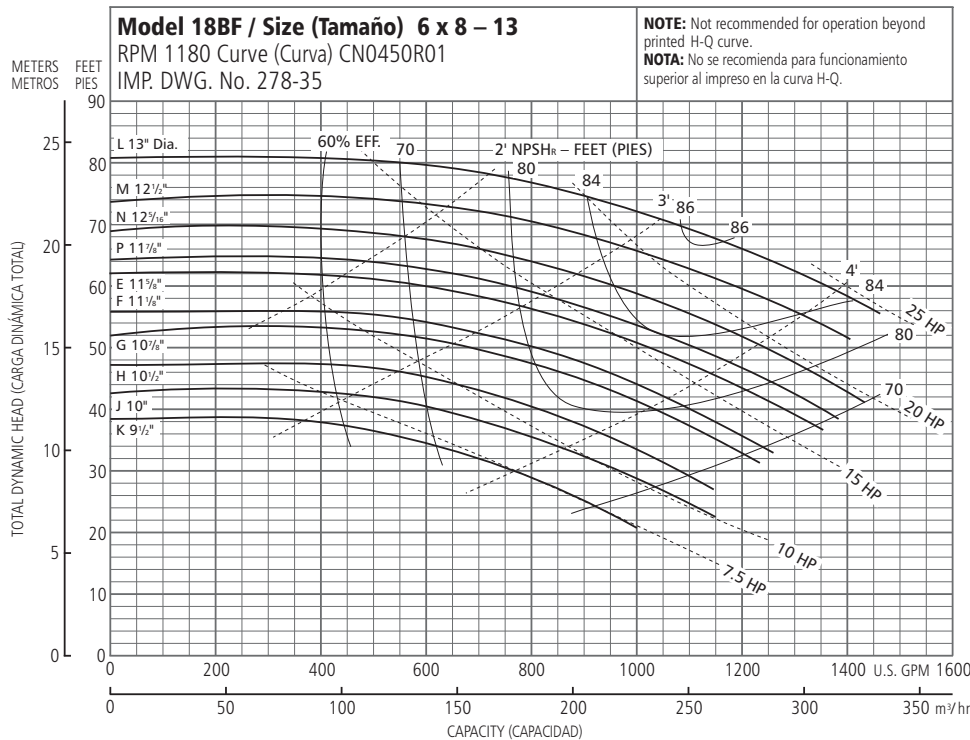

| Optional Impeller Impulsor optativo | |
|--|---------------------------------|
| Ordering Code Código de pedido | Dia. Diá. |
| L | 13" |
| M | 12 ¹ / ₂ |
| N | 12 ⁵ / ₁₆ |
| P | 11 ⁷ / ₈ |
| E | 11 ⁵ / ₈ |
| F | 11 ¹ / ₈ |
| G | 10 ⁷ / ₈ |
| H | 10 ¹ / ₂ |
| J | 10 |
| K | 9 ¹ / ₂ |

NOTE: Pump will pass a sphere to 7/8" diameter.
NOTA: La bomba dejará pasar una esfera de hasta 7/8 de pulgada de diámetro.

Performance Curves – 60 Hz, 1180 RPM
Curvas de desempeño – 60 Hz, 1180 RPM

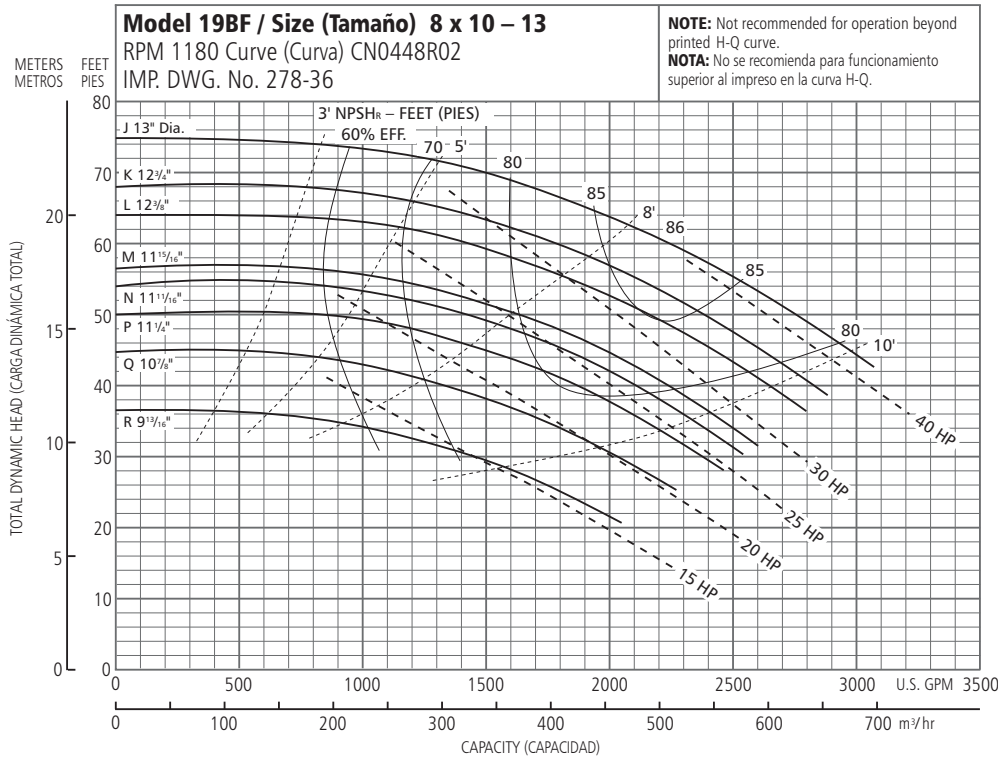

Optional Impeller
Impulsor optativo

| Ordering Code Código de pedido | Dia. Diá. |
|-----------------------------------|--------------|
| J | 13" |
| K | 12 3/4" |
| L | 12 3/8" |
| M | 11 15/16" |
| N | 11 1/16" |
| P | 11 1/4" |
| Q | 10 7/8" |
| R | 9 13/16" |

NOTE: Pump will pass a sphere to 7/8" diameter.
NOTA: La bomba dejará pasar una esfera de hasta 7/8 de pulgada de diámetro.

Performance Curves – 50 Hz, 2900 RPM
Curvas de desempeño – 50 Hz, 2900 RPM

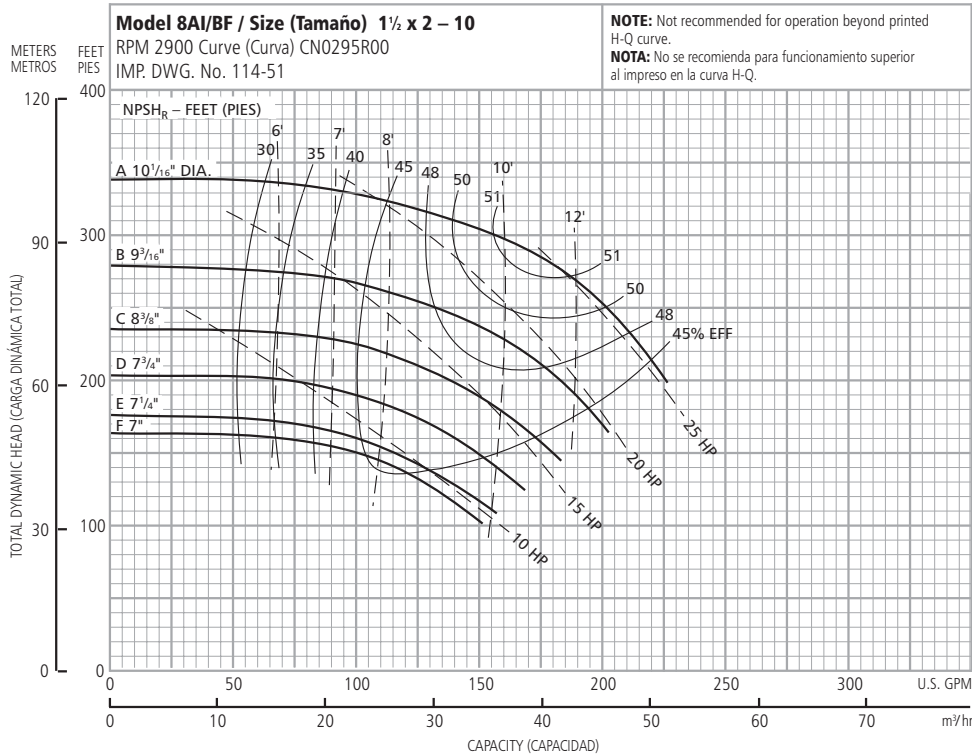

Optional Impeller
Impulsor optativo

| Ordering Code Código de pedido | Dia. Diá. |
|-----------------------------------|--------------|
| A | 10 1/16" |
| B | 9 3/16" |
| C | 8 3/8" |
| D | 7 3/4" |
| E | 7 1/4" |
| F | 7" |

NOTE: Pump will pass a sphere to 3/32" diameter.
NOTA: La bomba dejará pasar una esfera de hasta 3/32 de pulgada de diámetro.

Performance Curves – 50 Hz, 2900 RPM

Curvas de desempeño – 50 Hz, 2900 RPM

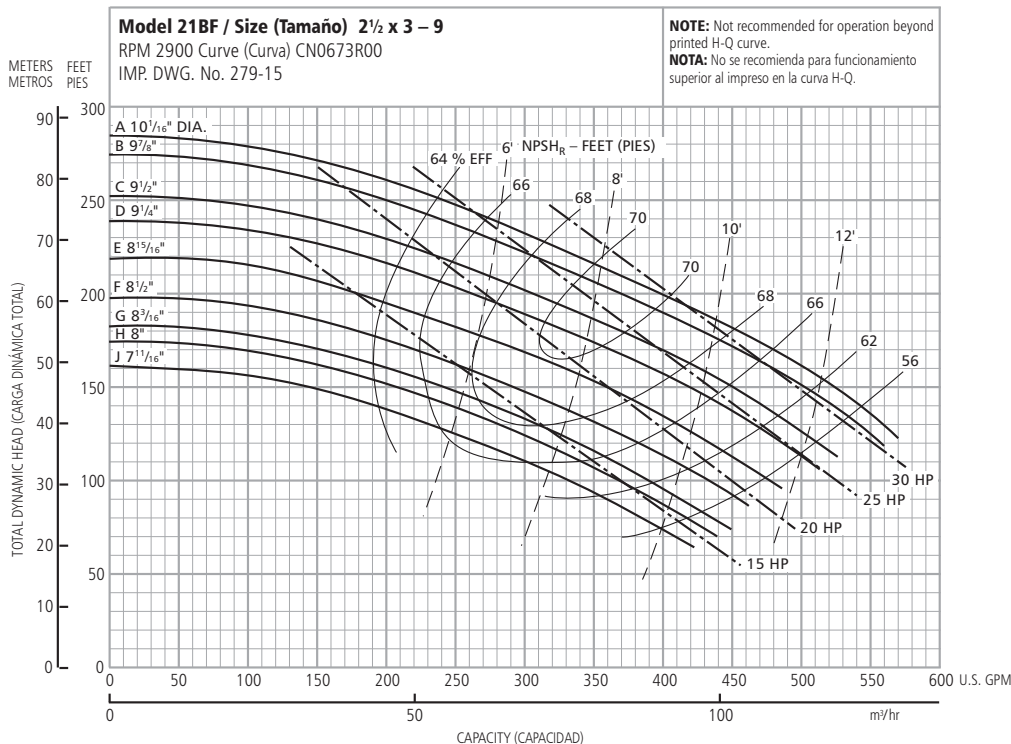
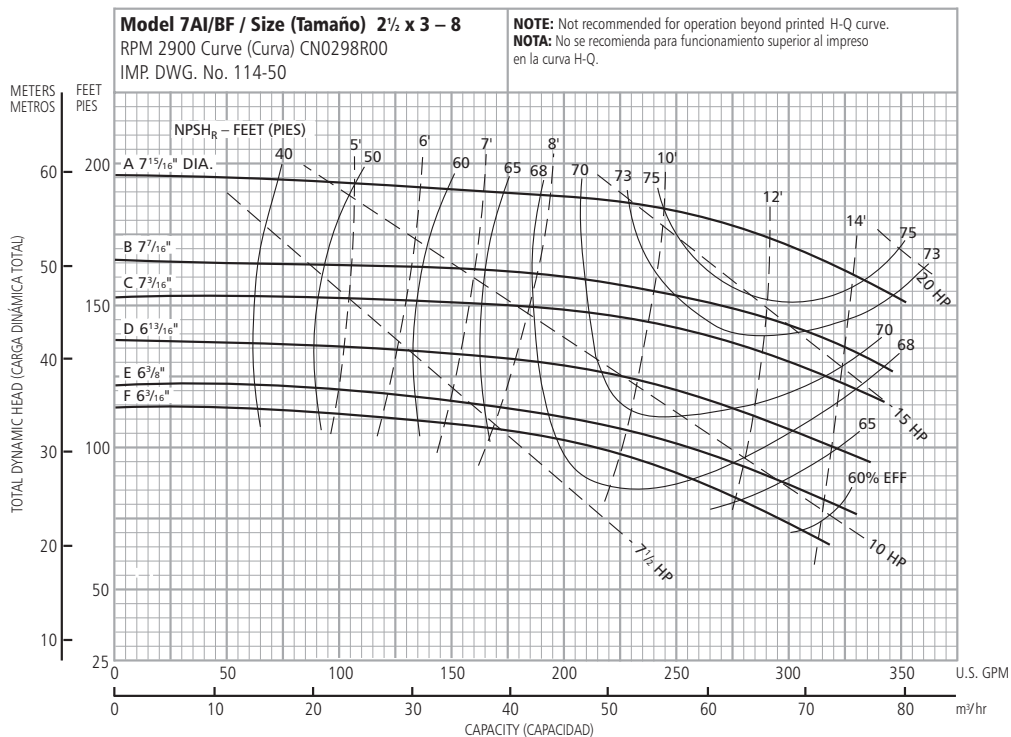

Performance Curves – 50 Hz, 2900 RPM
Curvas de desempeño – 50 Hz, 2900 RPM

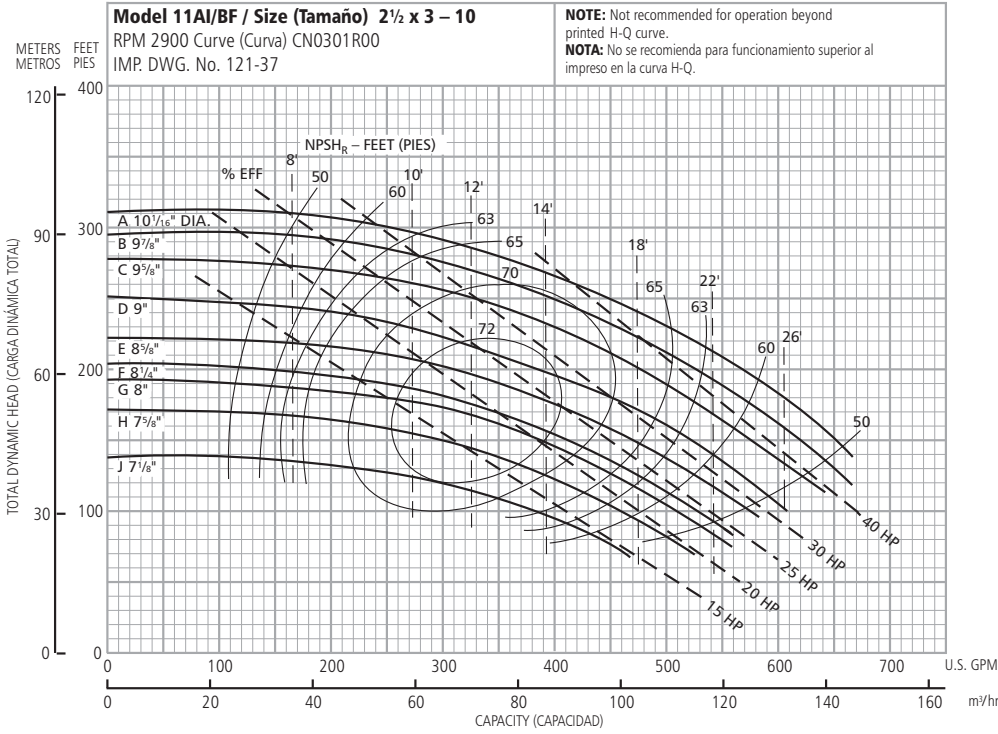

| Optional Impeller Impulsor optativo | |
|--|--------------|
| Ordering Code Código de pedido | Dia. Diá. |
| A | 10 1/16" |
| B | 9 7/8 |
| C | 9 3/8 |
| D | 9 |
| E | 8 5/8 |
| F | 8 1/4 |
| G | 8 |
| H | 7 5/8 |
| J | 7 1/8 |

NOTE: Pump will pass a sphere to 5/16" diameter.
NOTA: La bomba dejará pasar una esfera de hasta 5/16 de pulgada de diámetro.

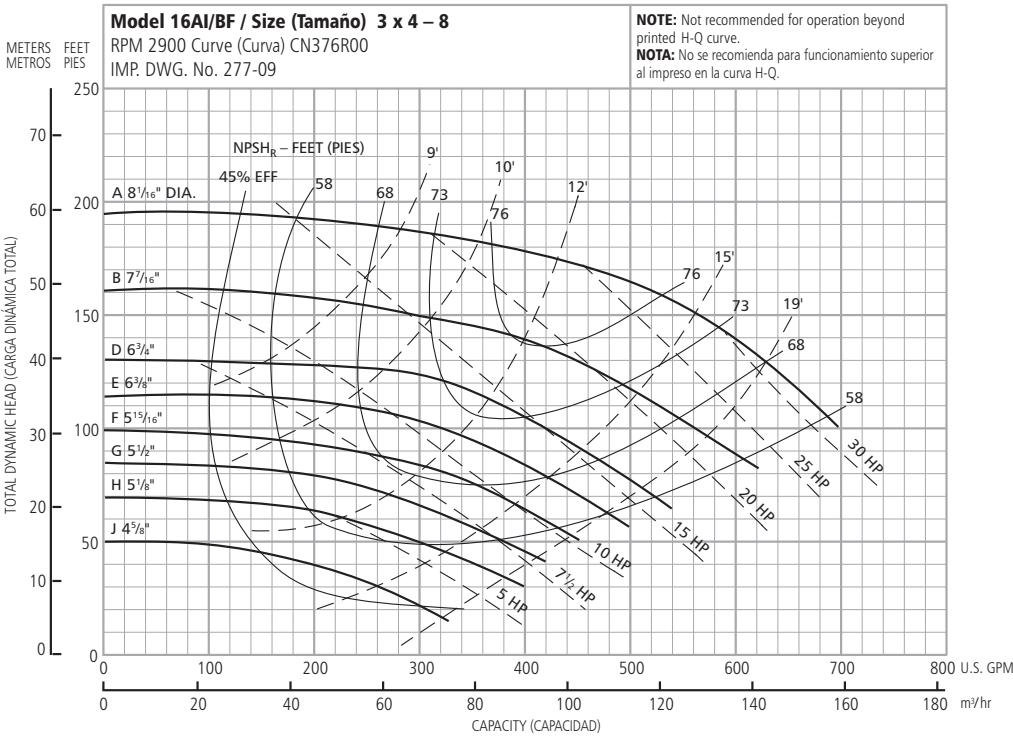

| Optional Impeller Impulsor optativo | |
|--|--------------|
| Ordering Code Código de pedido | Dia. Diá. |
| A | 8 1/8" |
| B | 7 7/16 |
| D | 6 3/4 |
| E | 6 3/8 |
| F | 5 15/16 |
| G | 5 1/2 |
| H | 5 1/8 |
| J | 4 5/8 |

NOTE: Pump will pass a sphere to 5/16" diameter.
NOTA: La bomba dejará pasar una esfera de hasta 5/16 de pulgada de diámetro.

Performance Curves – 50 Hz, 2900 RPM
Curvas de desempeño – 50 Hz, 2900 RPM

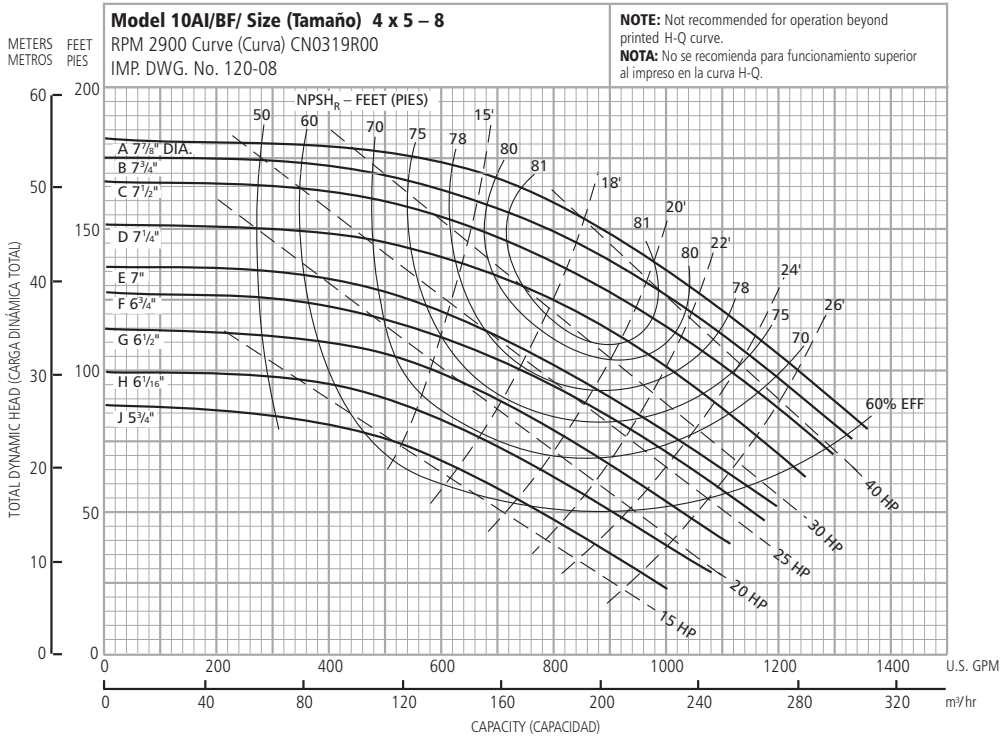

Optional Impeller Impulsor optativo

| Ordering Code Código de pedido | Dia. Diá. |
|--------------------------------|-----------|
| A | 7 7/8" |
| B | 7 3/4" |
| C | 7 1/2" |
| D | 7 1/4" |
| E | 7" |
| F | 6 3/4" |
| G | 6 1/2" |
| H | 6 1/16" |
| J | 5 3/4" |

NOTE: Pump will pass a sphere to 5/16" diameter.
NOTA: La bomba dejará pasar una esfera de hasta 5/16 de pulgada de diámetro.

Performance Curves – 50 Hz, 1450 RPM
Curvas de desempeño – 50 Hz, 1450 RPM

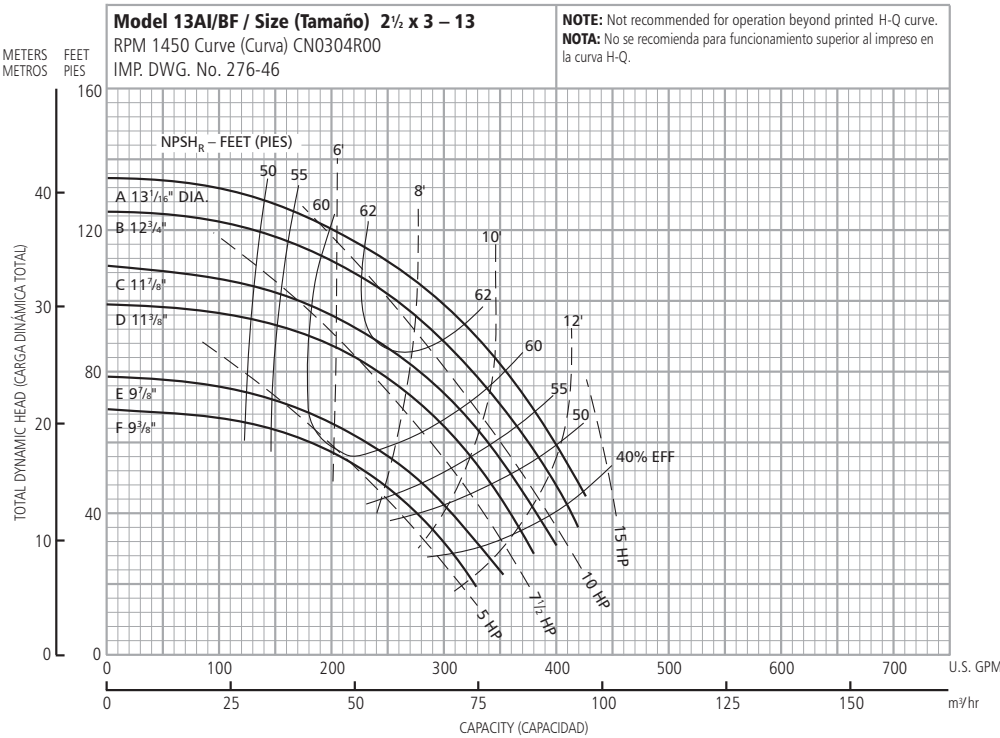

Optional Impeller Impulsor optativo

| Ordering Code Código de pedido | Dia. Diá. |
|--------------------------------|-----------|
| A | 13 1/16" |
| B | 12 3/4" |
| C | 11 7/8" |
| D | 11 3/8" |
| E | 9 7/8" |
| F | 9 3/8" |

NOTE: Pump will pass a sphere to 5/16" diameter.
NOTA: La bomba dejará pasar una esfera de hasta 5/16 de pulgada de diámetro.

Performance Curves – 50 Hz, 1450 RPM
Curvas de desempeño – 50 Hz, 1450 RPM

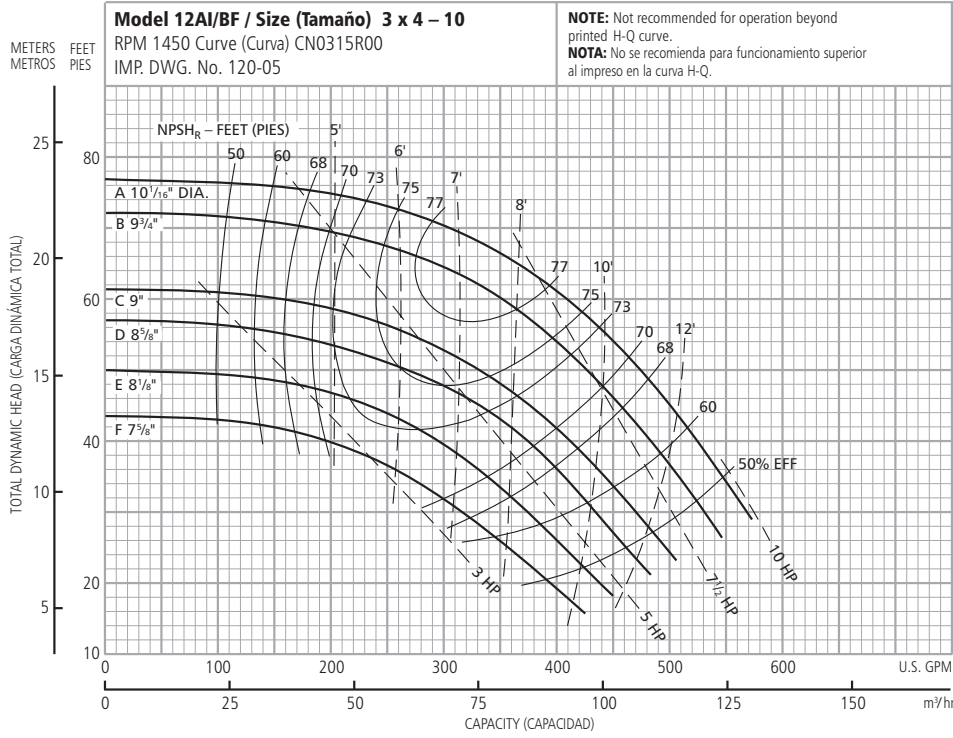

| Optional Impeller Impulsor optativo | |
|--|--------------|
| Ordering Code Código de pedido | Dia. Diá. |
| A | 10 1/16" |
| B | 9 3/4 |
| C | 9 |
| D | 8 5/8 |
| E | 8 1/8 |
| F | 7 7/8 |

NOTE: Pump will pass a sphere to 3/8" diameter.
NOTA: La bomba dejará pasar una esfera de hasta 3/8 de pulgada de diámetro.

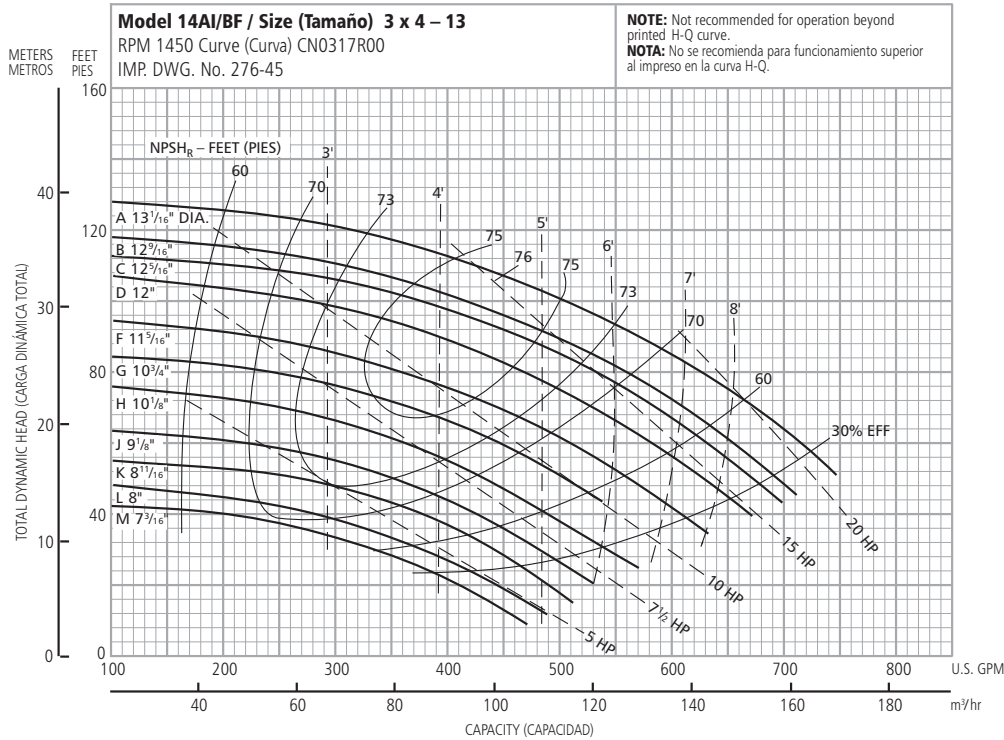

| Optional Impeller Impulsor optativo | |
|--|--------------|
| Ordering Code Código de pedido | Dia. Diá. |
| A | 13 1/16" |
| B | 12 9/16 |
| C | 12 5/16 |
| D | 12 |
| F | 11 3/16 |
| G | 10 3/4 |
| H | 10 1/8 |
| J | 9 1/8 |
| K | 8 11/16 |
| L | 8 |
| M | 7 3/16 |

NOTE: Pump will pass a sphere to 3/8" diameter.
NOTA: La bomba dejará pasar una esfera de hasta 3/8 de pulgada de diámetro.

Performance Curves – 50 Hz, 1450 RPM
Curvas de desempeño – 50 Hz, 1450 RPM

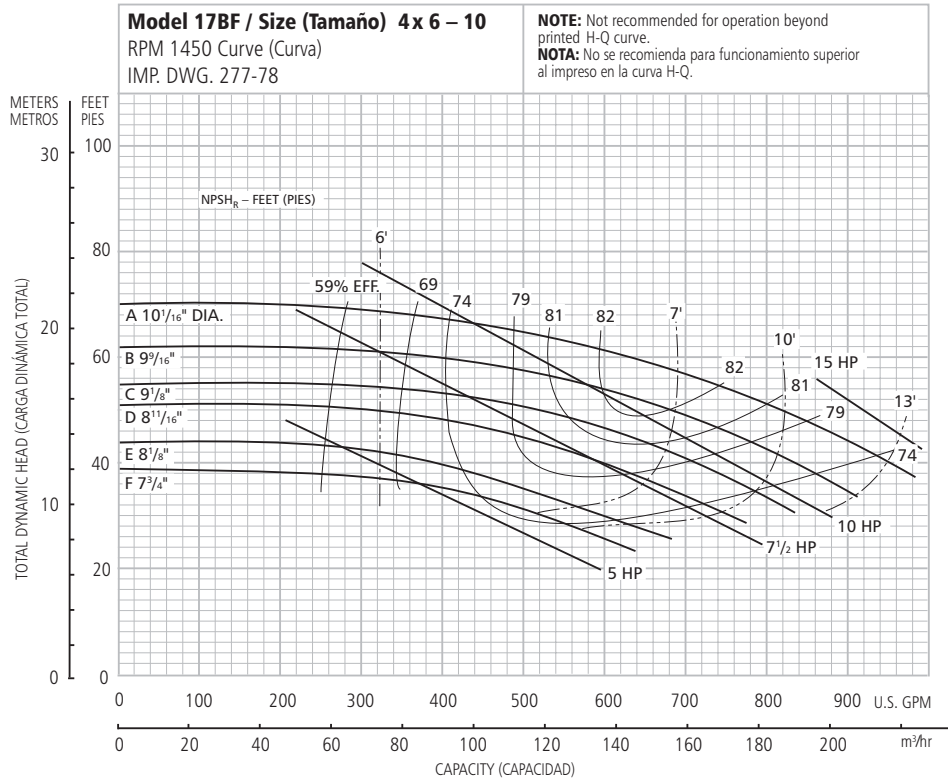

| Optional Impeller Impulsor optativo | |
|--|-----------------------------------|
| Ordering Code Código de pedido | Dia. Diá. |
| A | 10 ¹ / ₁₆ " |
| B | 9 ⁹ / ₁₆ |
| C | 9 ¹ / ₈ |
| D | 8 ¹¹ / ₁₆ |
| E | 8 ¹ / ₈ |
| F | 7 ³ / ₄ |

NOTE: Pump will pass a sphere to ⁷/₁₆" diameter.
NOTA: La bomba dejará pasar una esfera de hasta ⁷/₁₆ de pulgada de diámetro.

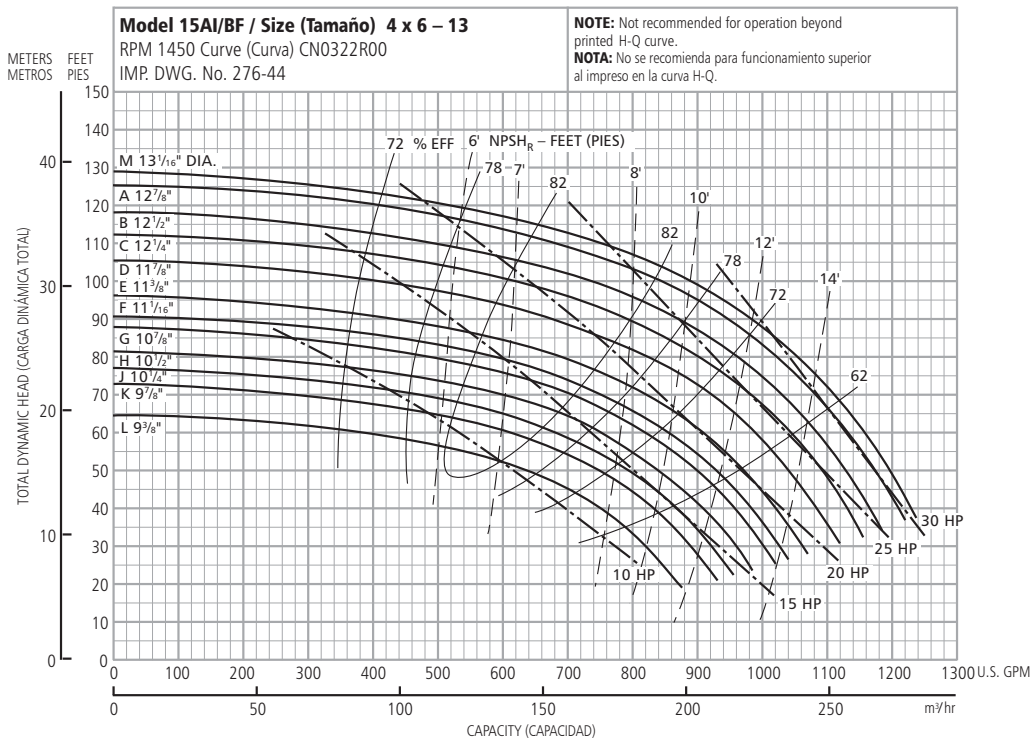

| Optional Impeller Impulsor optativo | |
|--|-----------------------------------|
| Ordering Code Código de pedido | Dia. Diá. |
| M | 13 ¹ / ₁₆ " |
| A | 12 ⁷ / ₈ |
| B | 12 ¹ / ₂ |
| C | 12 ¹ / ₄ |
| D | 11 ⁷ / ₈ |
| E | 11 ³ / ₈ |
| F | 11 ¹ / ₁₆ |
| G | 10 ⁷ / ₈ |
| H | 10 ¹ / ₂ |
| J | 10 ¹ / ₄ |
| K | 9 ⁷ / ₈ |
| L | 9 ³ / ₈ |

NOTE: Pump will pass a sphere to ⁷/₁₆" diameter.
NOTA: La bomba dejará pasar una esfera de hasta ⁷/₁₆ de pulgada de diámetro.

Performance Curves – 50 Hz, 1450 RPM
Curvas de desempeño – 50 Hz, 1450 RPM

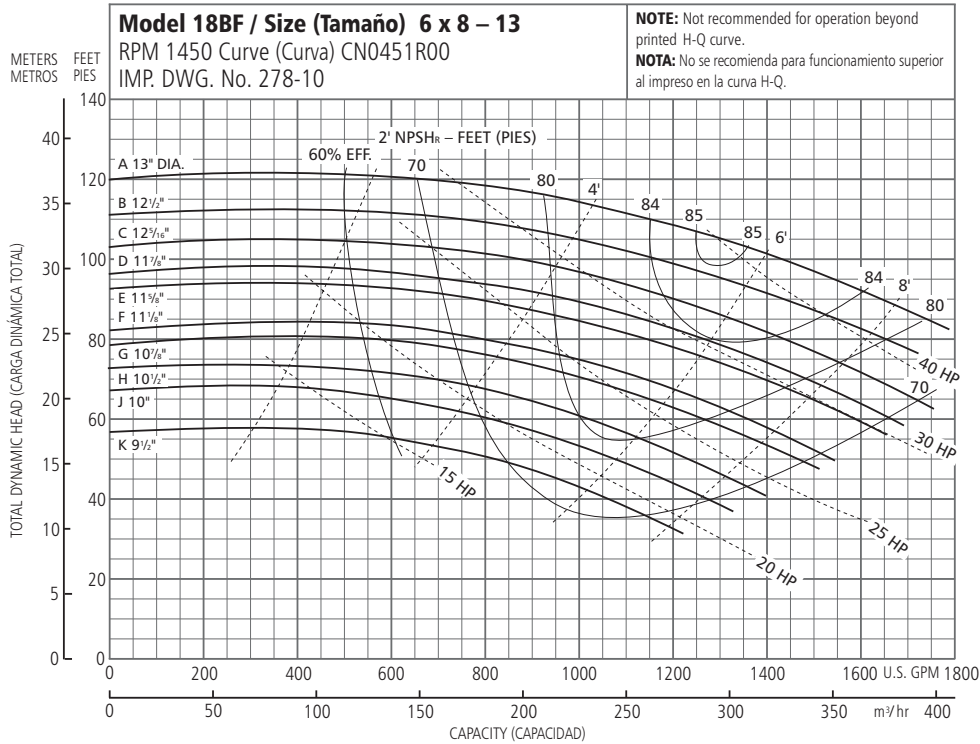

Optional Impeller Impulsor optativo

| Ordering Code Código de pedido | Dia. Diá. |
|--------------------------------|-----------|
| ■ A | 13" |
| ■ B | 12 1/2" |
| ■ C | 12 5/16" |
| ■ D | 11 7/8" |
| E | 11 5/8" |
| F | 11 1/8" |
| G | 10 7/8" |
| H | 10 1/2" |
| J | 10" |
| K | 9 1/2" |

NOTE: Pump will pass a sphere to 7/8" diameter.
NOTA: La bomba dejará pasar una esfera de hasta 7/8 de pulgada de diámetro.
 ■ Indicates "L" Group pump.
 ■ Indica una bomba Grupo "L".

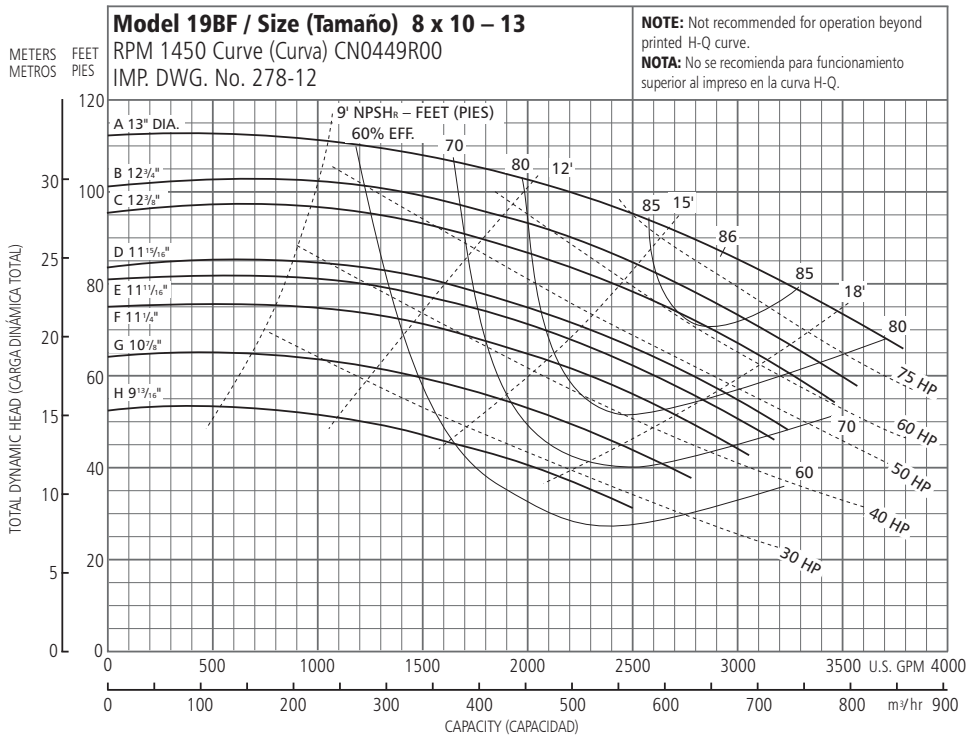

Optional Impeller Impulsor optativo

| Ordering Code Código de pedido | Dia. Diá. |
|--------------------------------|-----------|
| ■ A | 13" |
| ■ B | 12 3/4" |
| ■ C | 12 3/8" |
| ■ D | 11 15/16" |
| ● E | 11 11/16" |
| ● F | 11 1/4" |
| ● G | 10 7/8" |
| ● H | 9 13/16" |

NOTE: Pump will pass a sphere to 7/16" diameter.
NOTA: La bomba dejará pasar una esfera de hasta 7/16 de pulgada de diámetro.
 ■ Indicates "L" Group pump.
 ■ Indica una bomba Grupo "L".
 ● For close coupled version, consult factory.
 ● Para la versión compacta, consulte con la fábrica.

Performance Curves – Variable Speed
Curvas de desempeño – Velocidad variable

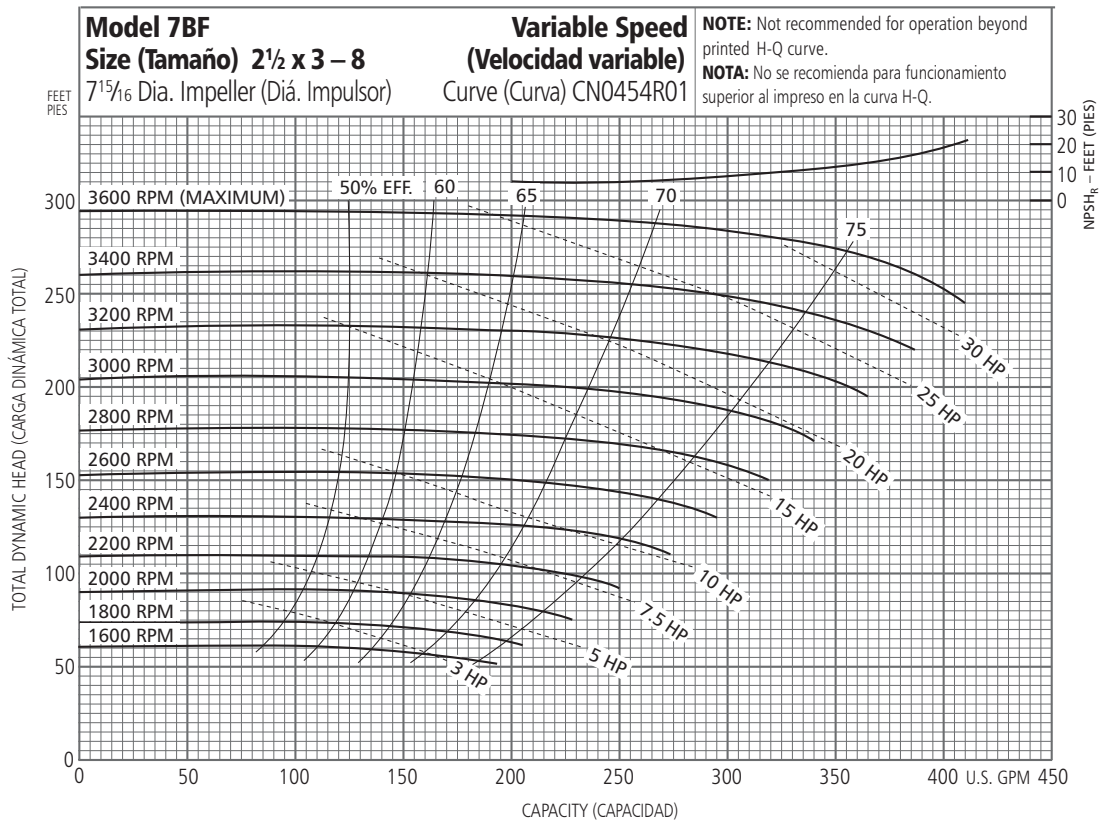
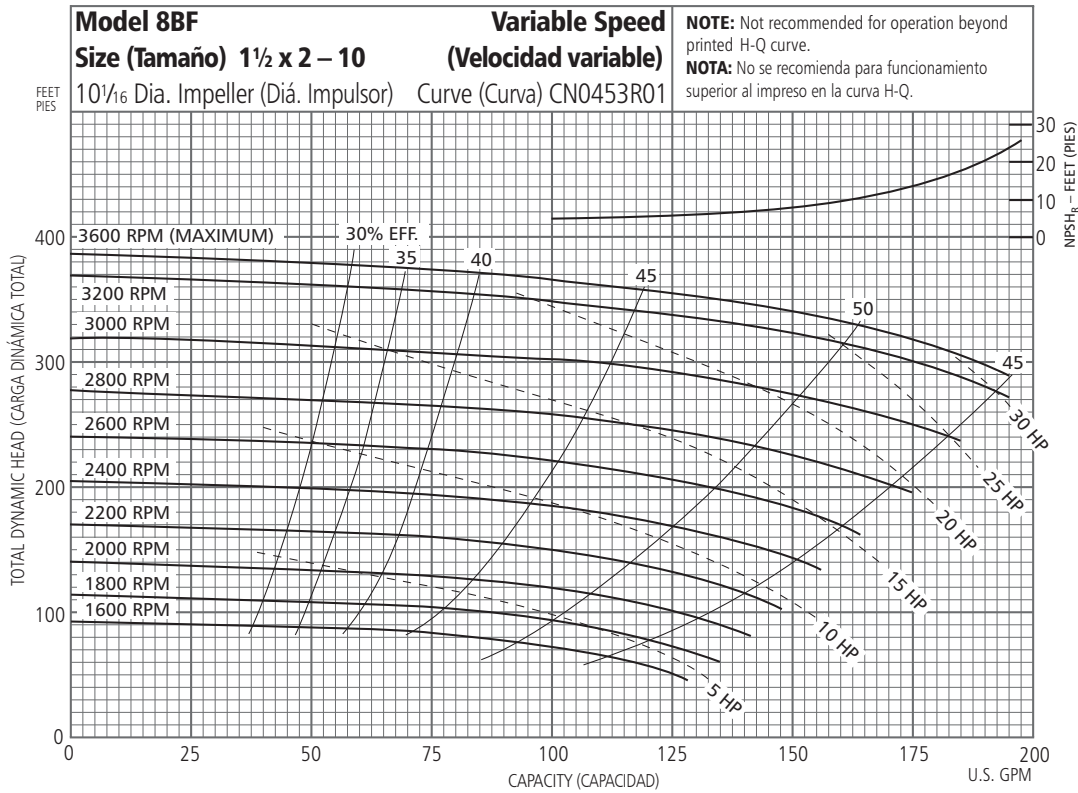

Performance Curves – Variable Speed
Curvas de desempeño – Velocidad variable

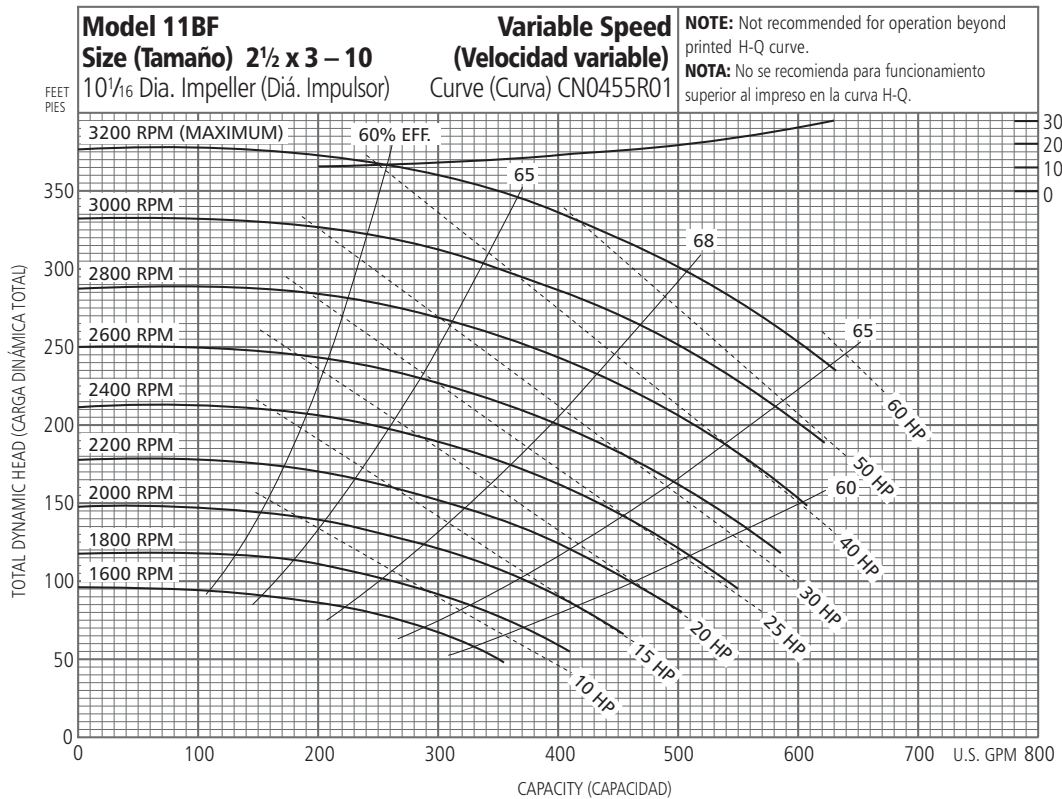
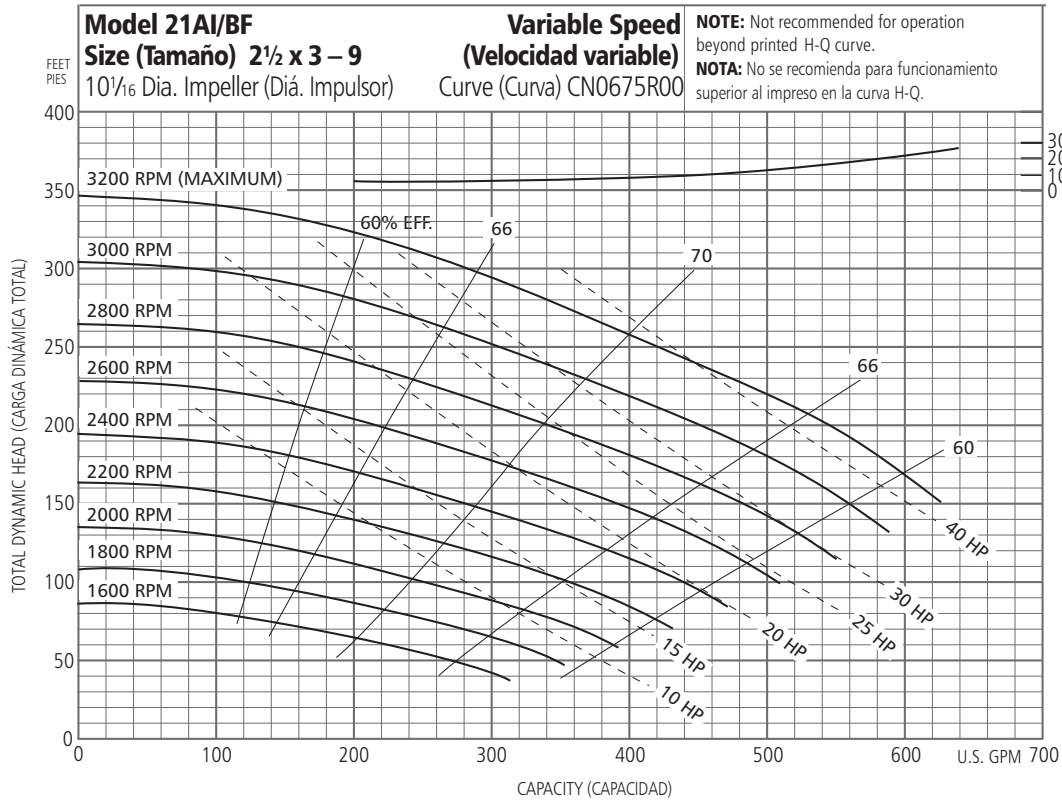

Performance Curves – Variable Speed
Curvas de desempeño – Velocidad variable

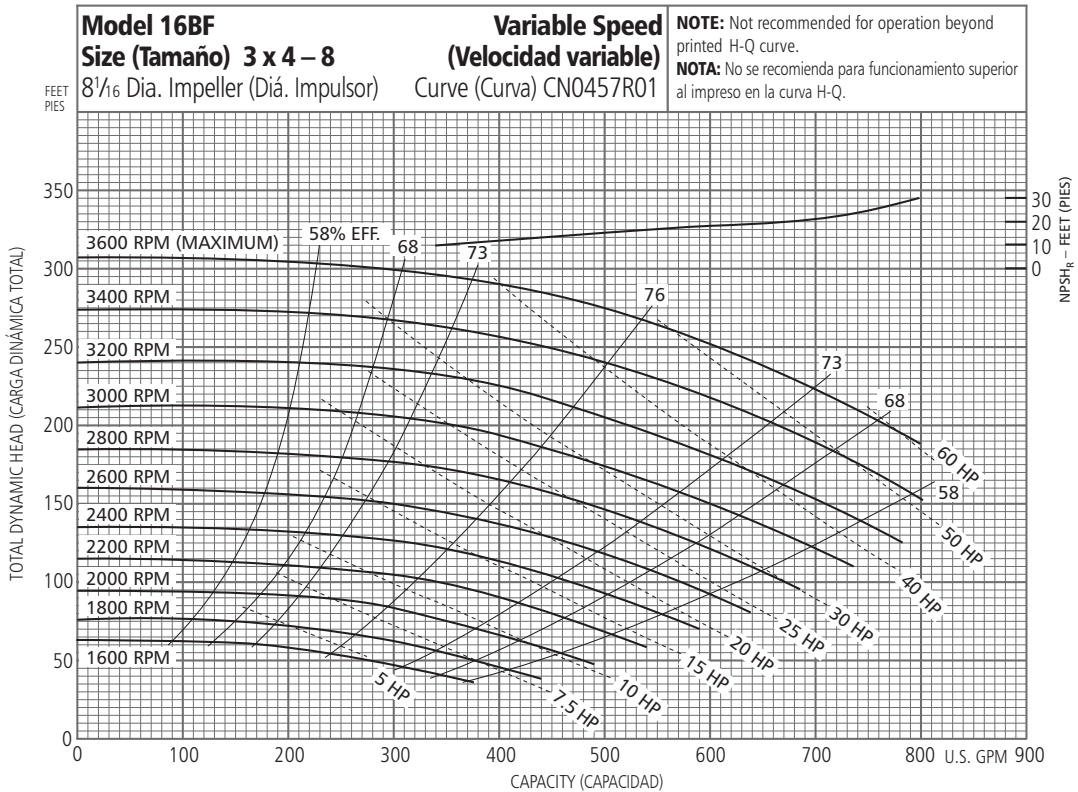
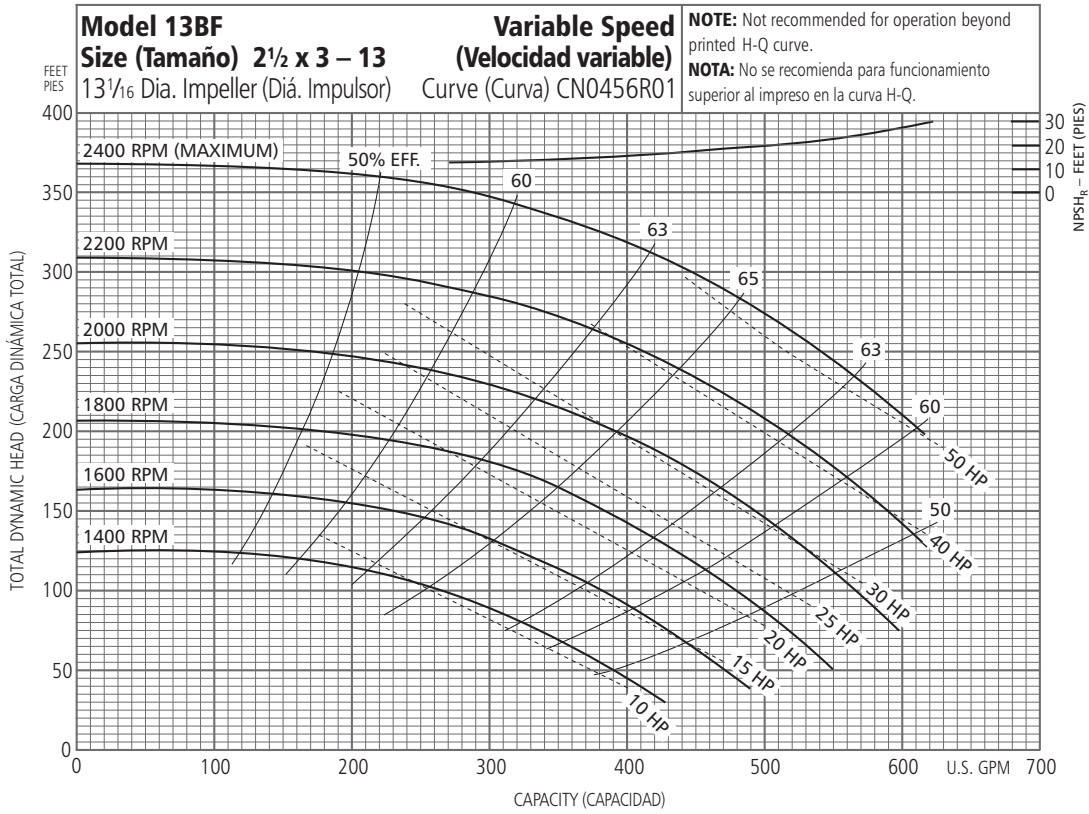

Performance Curves – Variable Speed
Curvas de desempeño – Velocidad variable

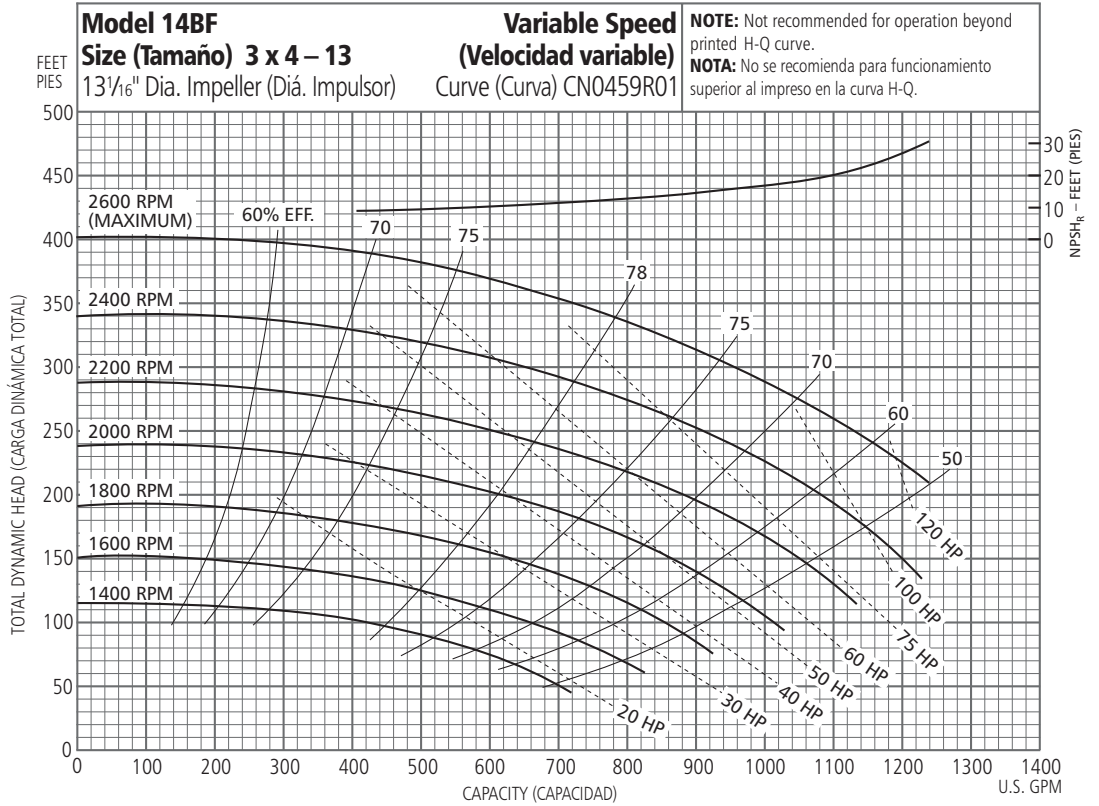
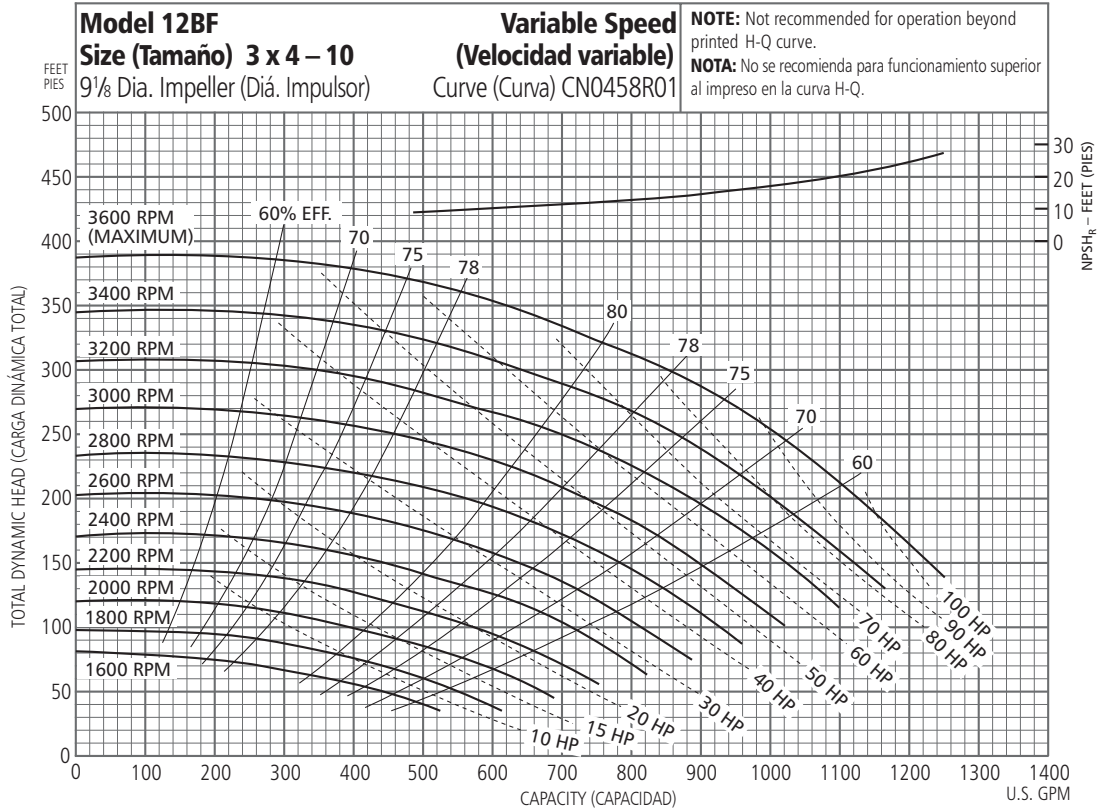

Performance Curves – Variable Speed
Curvas de desempeño – Velocidad variable

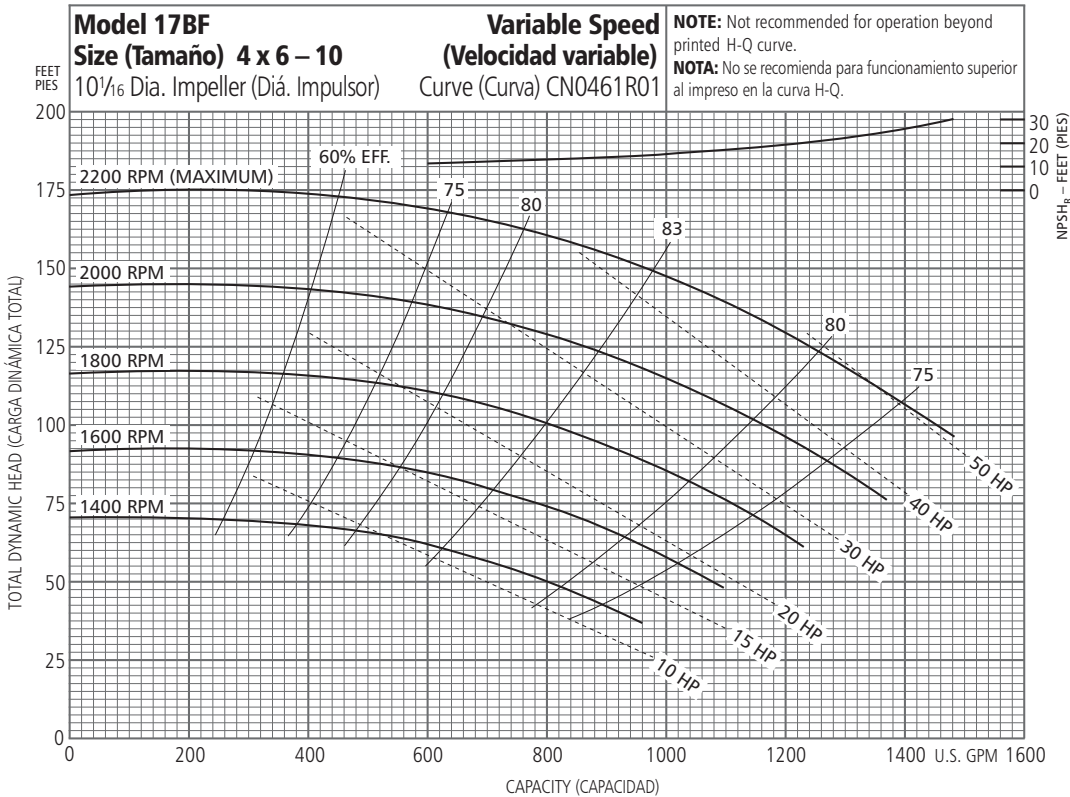
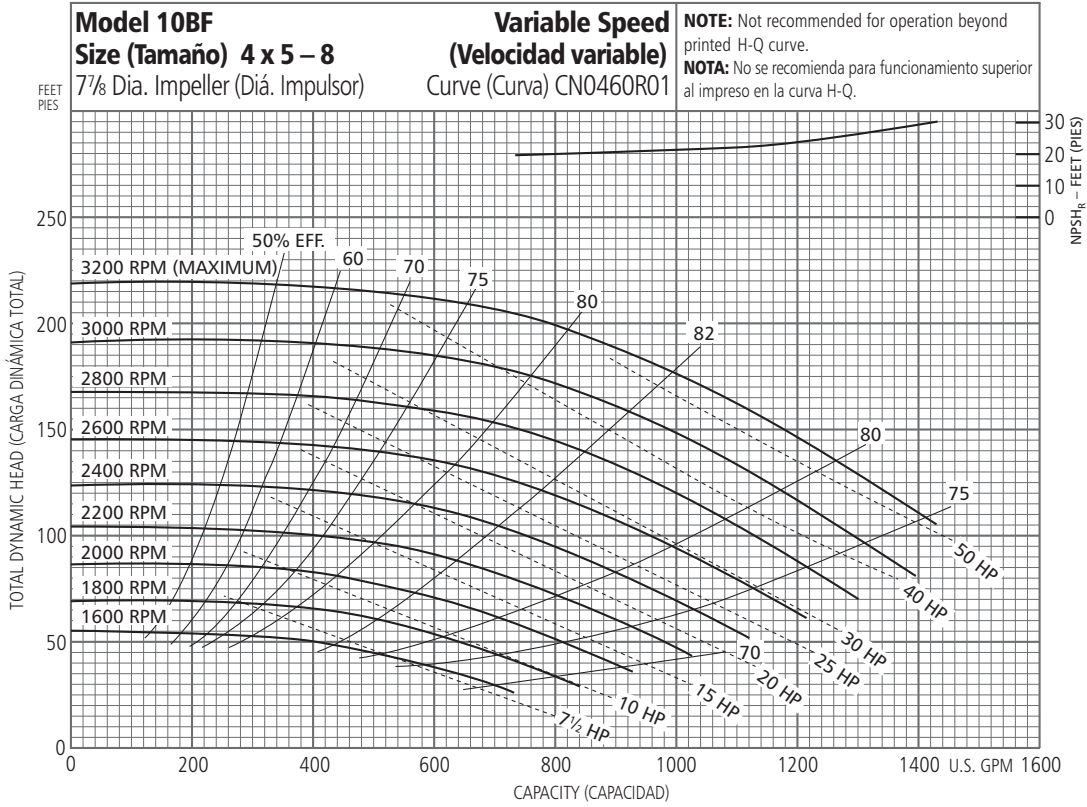

Performance Curves – Variable Speed
Curvas de desempeño – Velocidad variable

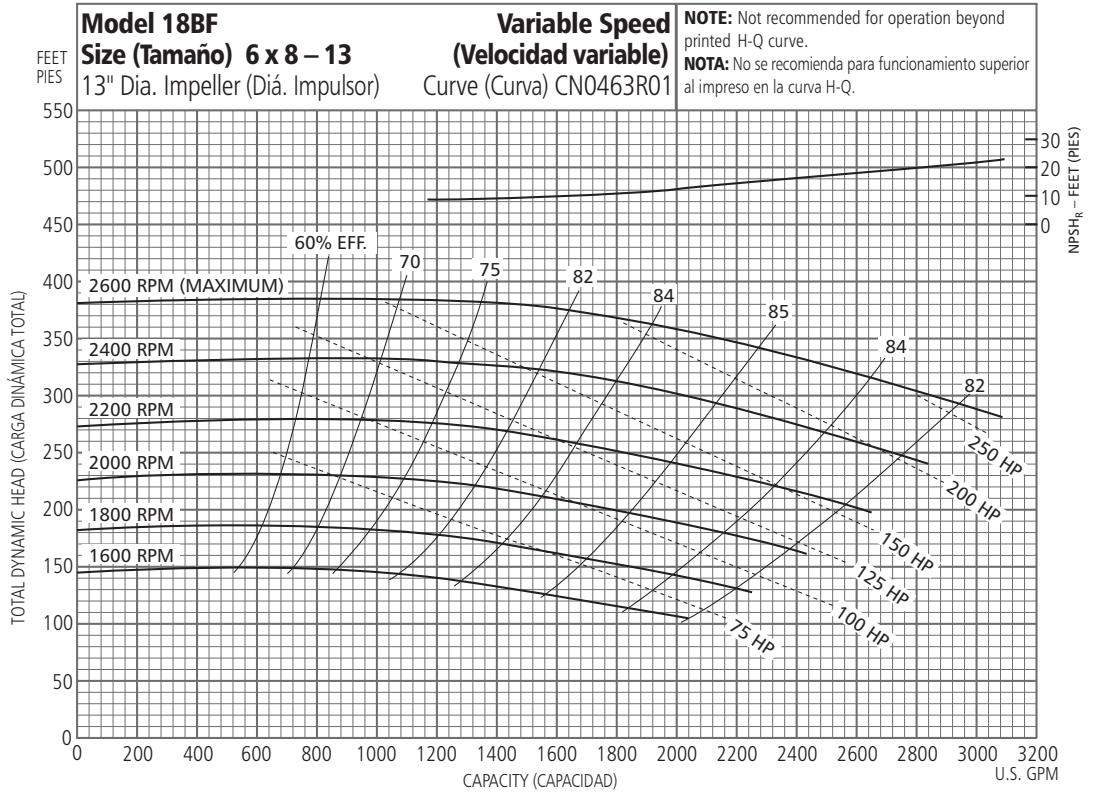
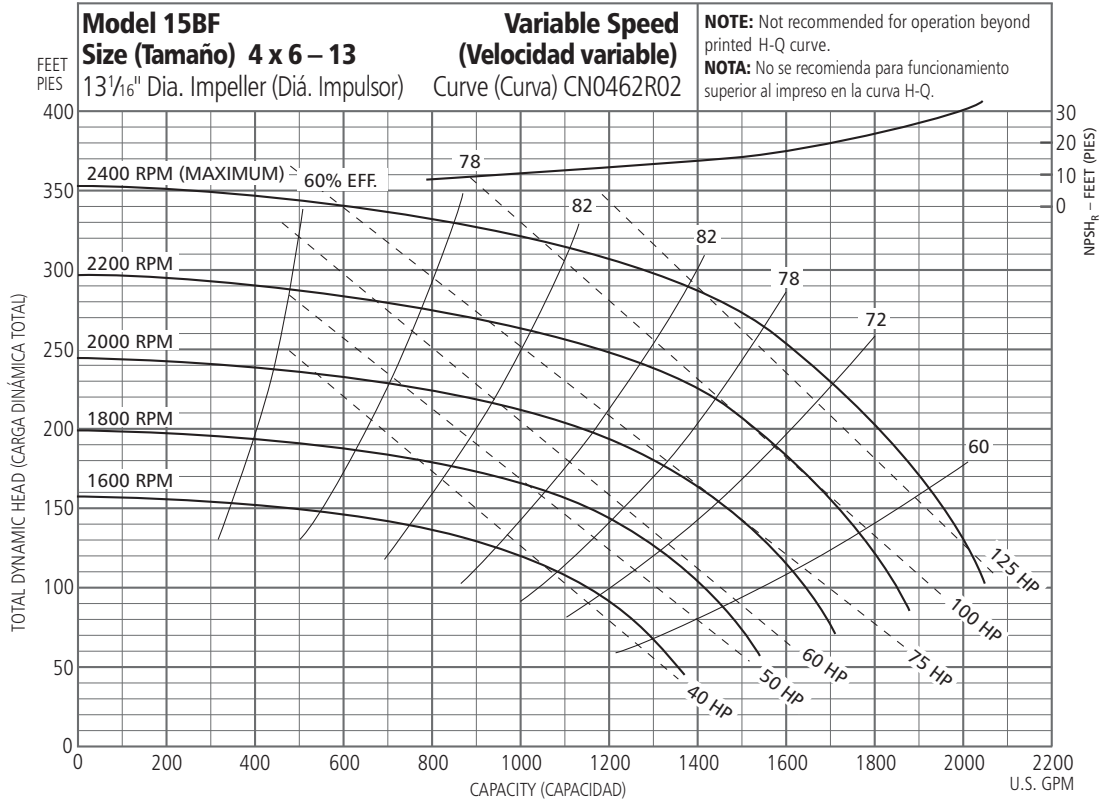

Performance Curves – Variable Speed
Curvas de desempeño – Velocidad variable

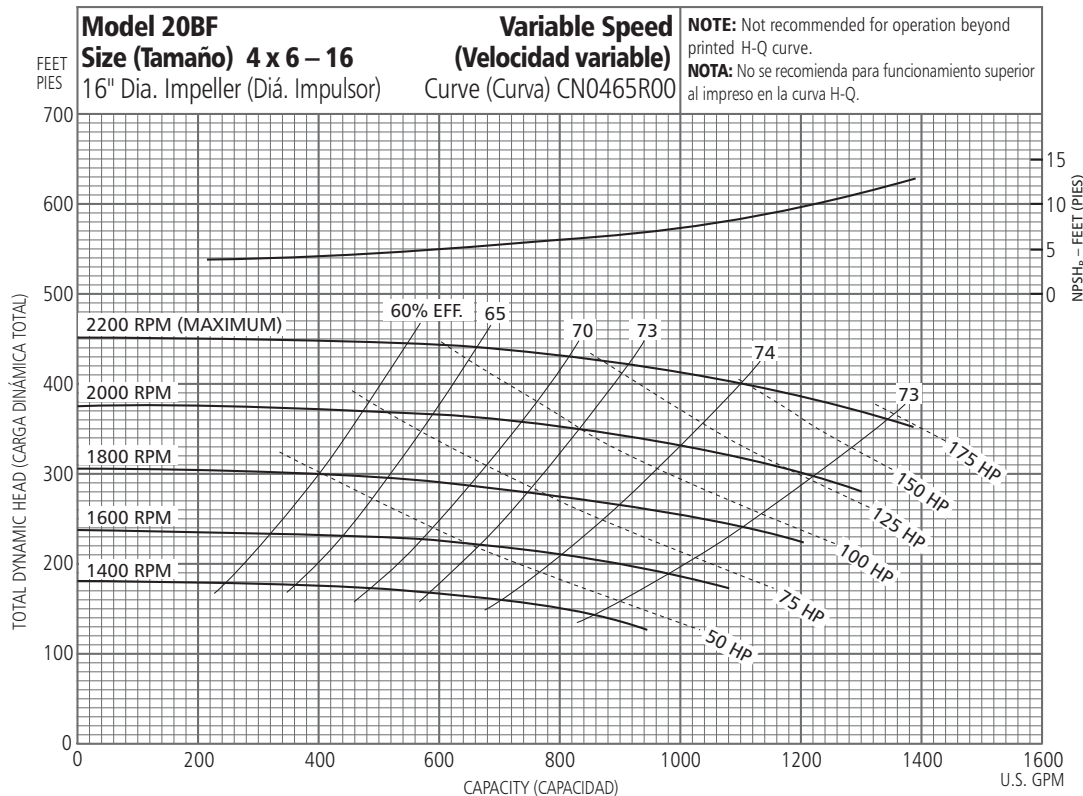
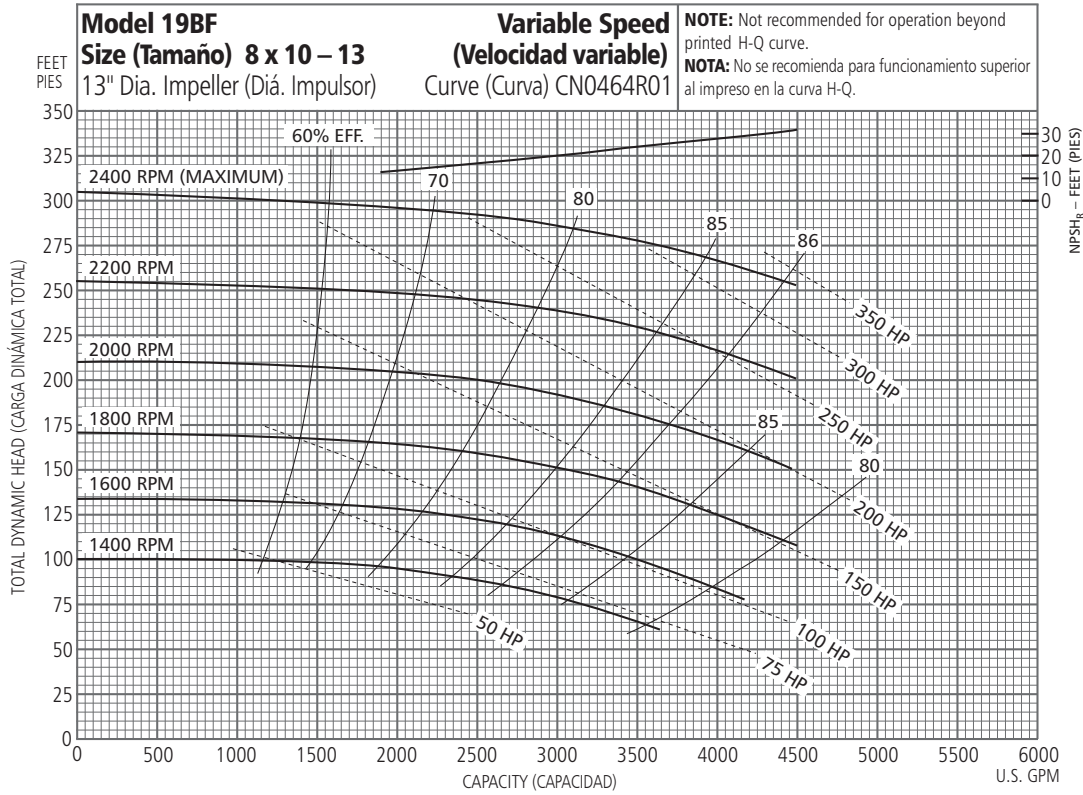

3656 M & L-Group Materials of Construction

Materiales de construcción - Grupo M y L, modelo 3656

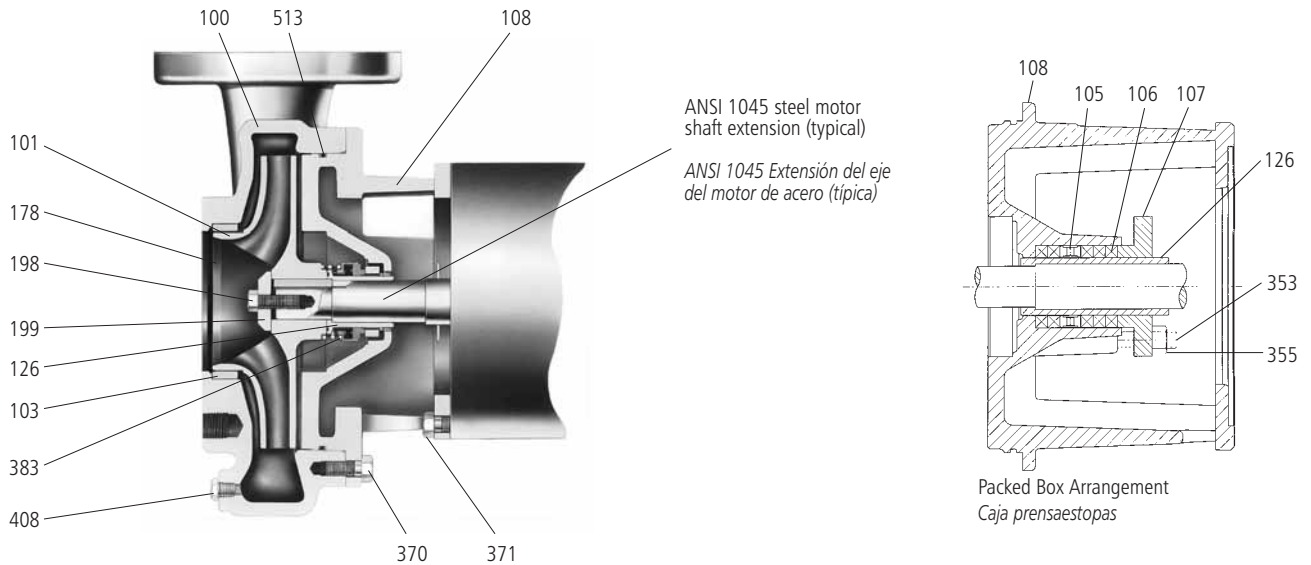

| Item No. No. Ítem | Description Descripción | Materials, Materiales | |
|-------------------------|--|--|---------------------------------------|
| | | All Iron Todo hierro | Bronze Fitted Accesorios de bronce |
| 100 | Casing, Carcasa | | 1003 |
| 101 | Impeller, Impulsor | | 1101 |
| 103 | Casing wear ring, Anillo de desgaste de la carcasa | 1001 | 1618 |
| 108 | Adapter/seal housing, Adaptador/Cubierta del sello | | 1001 |
| 126 | Shaft sleeve, Camisa del eje | | |
| 178 | Impeller key, Chaveta del impulsor | AISI Type 300 Series SS Acero inoxidable serie AISI tipo 300 | |
| 198 | Impeller bolt, Tornillo del impulsor | | |
| 199 | Impeller washer, Arandela del impulsor | | |
| 370 | Hex head cap screw (adapter to case), Tornillo de cabeza hexagonal (del adaptador a la cubierta) | Steel Zinc Platted Grade 5 Acero SAE 1200 grado 5 | |
| 371 | Hex head cap screw (adapter to motor), Tornillo de cabeza hexagonal (del adaptador al motor) | | |
| 383 | Mechanical seal, Sello mecánico | See seal chart, Ver tabla del sello | |
| 408 | Pipe plug 1/4" or 3/8", Tapón de tubos de 1/4 de pulgada ó 3/8 de pulgada | Zinc Platted Steel Zinc Platted Steel | |
| 513 | O-ring, Anillo en O | BUNA-N – Standard, EPR – Optional Viton – Optional | |

| Material Code Código de material | Engineering Standard Norma de ingeniería |
|-------------------------------------|--|
| 1003 | Cast iron ASTM A48 CL30 Hierro fundido ASTM A48 CL20 |
| 1618 | Bismuth Bronze – Lead Free, Bismuth Bronze – Lead Free |
| 1001 | Cast iron ASTM A48 CL20 Hierro fundido ASTM A48 CL20 |
| 1101 | ASTM B584, Modified C87500 – Lead Free ASTM B584, modified C87500 – Lead Free |

Packed Box Arrangement, Caja prensaestopas

| Item No. No. ítem | Description Descripción | Materials Materiales |
|----------------------|---|--|
| 105 | Lantern ring Aro de linterna | Teflon™ |
| 106 | Packing, 5 rings Empaquetadura, 5 aros | Teflon Impregnated Impregnado de Teflon |
| 107 | Gland, Casquillo | AISI 316SS |
| 126 | Shaft sleeve Camisa del eje | |
| 353 | Gland stud Perno del casquillo | AISI Type 300 Series Stainless Steel Acero inoxidable serie AISI tipo 300 |
| 355 | Gland nut Tuerca del casquillo | |

NOTE:
Seal housing wear ring (item number 203) not shown. See repair parts page for detail. (Required for all models except 3 x 4 – 10.)

NOTA:
El anillo de desgaste del compartimiento de sello (ítem número 203) no se muestra. Consulte la página de piezas de repuesto para mayor detalle. (Se requiere para todos los modelos con excepción del 3 x 4 – 10).

Mechanical Seal Chart, Type 21, Tabla para sello mecánico, tipo 21

| Item No., No. ítem | Part No., Pieza Número | | | Rotary, Rotativo | Stationary, Estacionario | Elastomers, Elastómeros | Metal Parts, Partes Metálicas | Intended Duty, Servicio previsto |
|--------------------|-----------------------------|-----------------------------|---|------------------|--------------------------------|-------------------------|---------------------------------|--|
| | M-Group, Grupo-M | L-Group, Grupo-L | | | | | | |
| | 180JM-210JM 180JP-210CZ* | 250JM-360CZ 210JP-360CZ* | All motors, Todos los motores M Bearing Frame, Bastidor de cojinetes M L Bearing Frame, Bastidor de cojinetes L | | | | | |
| 383 | 10K13 | 10K16 | 10K84 | Carbon, Carbón | Ceramic, Cerámica | BUNA-N | 316 SS, 316 Acero inoxidable | Standard, Estándar |
| | 10K19 | 10K20 | Consult Factory, Consultar con la fábrica | | | | | High Temp, Caustic, Alta temp/Caustic |
| | 10K27 | 10K45 | 10K112 | Sil-Carbide | Sil-Carbide, Carburo de sílica | EPR | | Abrasive, Abrasivo |
| | 10K64 | 10K65 | 10K144 | | | | | Viton |
| | 15K17 | 15K3 | 15K4 | | | | | Packed Box Design with BUNA O-Ring, Diseño de prensaestopas empacado con anillo en O de BUNA |

* All Packed Box units use JP style motors, Todas las unidades de prensaestopas empacado utilizan motores estilo JP

3756 M & L-Group Materials of Construction

Materiales de construcción - Grupo M y L, modelo 3756

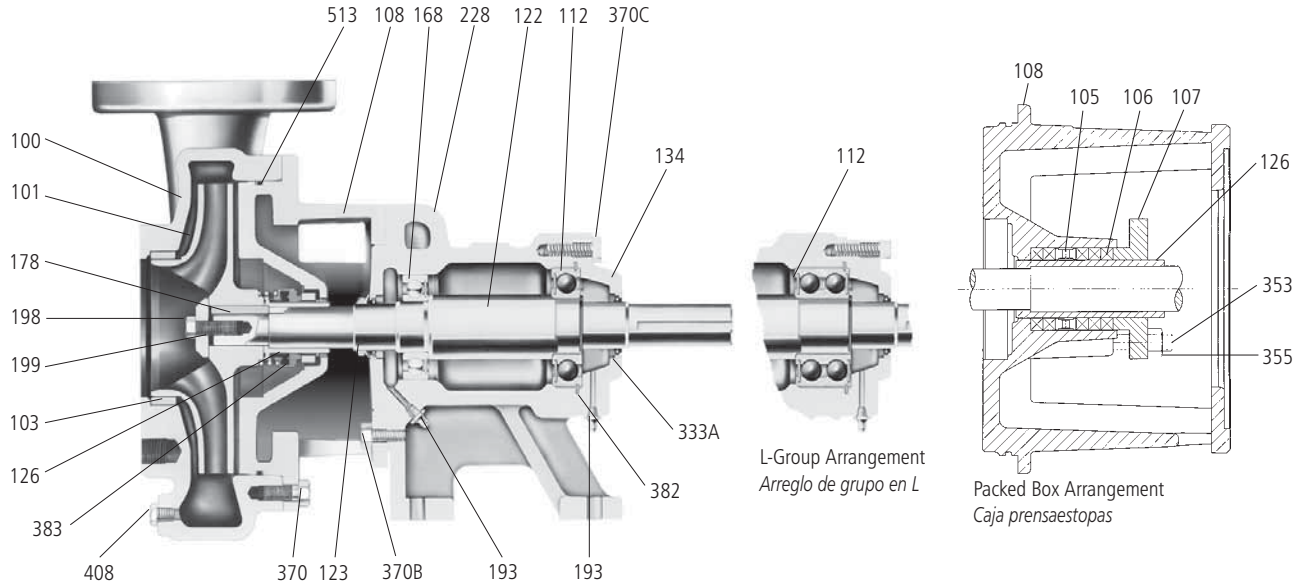

| Item No. No. Ítem | Description Descripción | Materials, Materiales | |
|-------------------------|--|---|--|
| | | All Iron Todo hierro | Bronze Fitted Accesorios de bronce |
| 100 | Casing, Carcasa | | 1003 |
| 101 | Impeller, Impulsor | | 1101 |
| 103 | Casing wear ring, Anillo de desgaste de la carcasa | 1001 | 1618 |
| 108 | Adapter/seal housing, Adaptador/Cubierta del sello | | 1001 |
| 126 | Shaft sleeve, Camisa del eje | | |
| 178 | Impeller key, Chaveta del impulsor | AISI Type 300 Series SS Acero inoxidable serie AISI tipo 300 | |
| 198 | Impeller bolt, Tornillo del impulsor | | |
| 199 | Impeller washer, Arandela del impulsor | | |
| 370 | Hex head cap screw (adapter to case), Tornillo de cabeza hexagonal (del adaptador a la cubierta) | Steel Zinc Plated Grade 5 Acero Zinc Plated grado 5 | |
| 370B | Hex head cap screw (adapter to bearing frame), Tornillo de cabeza hexagonal (del adaptador al motor) | | |
| 383 | Mechanical seal, Sello mecánico | See seal chart, Ver tabla del sello | |
| 408 | Pipe plug 1/4" or 3/8", Tapón de tubos de 1/4 de pulgada ó 3/8 de pulgada | Zinc Plated Steel, Zinc Plated Acero | |
| 513 | O-ring, Anillo en O | BUNA-N – Standard, Standard EPR – Optional, Optional Viton – Optional, Optional | |

Power End Components, Componentes del extremo de fuerza

| | | |
|-----|--------------------------------------|------------------------------|
| 228 | Bearing frame, Marco de cojinete | Cast iron ASTM A48 CL20 |
| 134 | Bearing cover, Cubierta del cojinete | Hierro fundido ASTM A48 CL20 |

| Item No. No. Ítem | Description Descripción | Materials, Materiales | |
|-------------------------|--|----------------------------|---|
| | | All Iron Todo hierro | Bronze Fitted Accesorios de bronce |
| 122 | Pump shaft, Eje de la bomba | | Steel, Acero |
| 168 | Ball bearing (inboard), Cojinete de bolas (interior) | | Steel, Acero |
| 112 | Ball bearing (outboard), Cojinete de bolas (exterior) | | Steel, Acero |
| 382 | Retaining ring, bearing, Anillo de retención, cojinete | | Steel Zinc Plated Grade 5, Acero Zinc Plated grado 5 |
| 370C | Hex head cap screw (bearing frame to cover), Tornillo de cabeza hexagonal (de la cubierta de cojinetes al marco) | | |
| 333A | Lip seal, Sello con reborde | | BUNA-N |
| 193 | Grease fitting, Accesorio grasa | | Steel, Acero |
| 123 | V-ring deflector, Anillo en V (Deflector) | | BUNA-N |

Packed Box Arrangement, Caja prensaestopas

| Item No. No. Ítem | Description Descripción | Materials Materiales |
|----------------------|---|--|
| 105 | Lantern ring Aro de linterna | Teflon™ |
| 106 | Packing, 5 rings Empaquetadura, 5 aros | Teflon Impregnated Impregnado de Teflon |
| 107 | Gland, Casquillo | AISI 316SS |
| 126 | Shaft sleeve Camisa del eje | |
| 353 | Gland stud Perno del casquillo | AISI Type 300 Series Stainless Steel Acero inoxidable serie AISI tipo 300 |
| 355 | Gland nut Tuerca del casquillo | |

Material Code Código de material

| Material Code Código de material | Engineering Standard Norma de ingeniería |
|-------------------------------------|--|
| 1001 | Cast iron ASTM A48 CL20 Hierro fundido ASTM A48 CL20 |
| 1102 | Sil-Brass ASTM B584, Modified C87500 – Lead Free Sil-Brass ASTM B584, Modified C87500 – Lead Free |
| 1003 | Cast Iron ASTM A48 CL30 Cast Iron ASTM A48 CL30 |
| 1618 | Bismuth Bronze – Lead Free Bismuth Bronze – Lead Free |

3656 M & L-Group Dimensions and Weights
Grupo M y L, modelo 3656 - Peso y dimensiones

Mechanical Seal
Sello mecánico

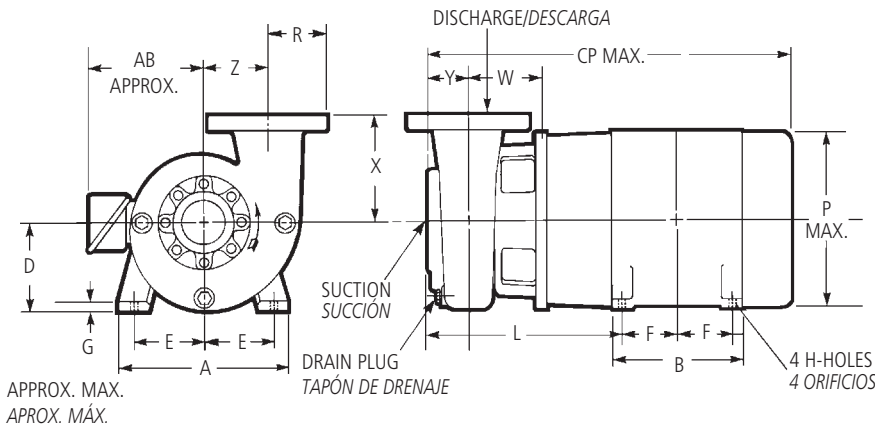

NOTE:

- All pumps shipped in vertical discharge position. For other orientations, remove casing bolts, rotate to desired position, and tighten 3/8" - 16 casing bolts to 37 ft./lbs. torque., 1/2" - 13 casing bolts to 90 ft./lbs. torque.
- Dimensions in inches, weight in pounds.
- Not to be used for construction purposes.

NOTA:

- Todas las bombas se embarcan con la descarga en posición vertical. Para otras orientaciones, retire los pernos de la carcasa, haga rotar la descarga hasta la posición deseada y ajuste los 16 pernos de 3/8" de pulgada a una torsión de 37 pies/libra, y los 13 pernos de 1/2 pulgada a 90 pies/libra.
- Dimensiones en pulgadas, peso en libras.
- No utilizar con fines de construcción.

Pump Dimensions and Weights (Dimension "L" determined by Pump and Motor)
Peso y dimensiones de la bomba (la dimension "L" esta determinada por la bomba y el motor)

| Pump Bomba | Suction Succión | Discharge Descarga | CP Max. | DC Max. | DD | R | NPT Drain Drenaje NPT | W | X | Y | Z | Weight (lbs) Pesos (libras) | L | | | | | | |
|----------------|-----------------|--------------------|---|---------|-------|---------|-----------------------|--------|-------|-------|-------|-----------------------------|---------------------------------|----------|----------|---------|--------|--------|--------|
| | | | | | | | | | | | | | Motor Frame, Bastidor del motor | | | | | | |
| | | | | | | | | | | | | | 140 | 180 | 210 | 250/280 | 320 | 360 | |
| 1 1/2 x 2 -10 | 2* | 1 1/2* | 30 3/4 | 6 3/4 | 5 7/8 | 1 1/4 | 1/4 | 5 | 6 | 3 | 5 1/2 | 93 | 10 7/8 | 11 1/2 | 12 1/2 | 12 3/4 | - | - | |
| 2 1/2 x 3 - 8 | 3* | 2 1/2* | 30 3/4 | 6 3/4 | 5 3/4 | 1 13/16 | 1/4 | 5 1/8 | 6 | 3 3/8 | 5 | 78 | 11 3/8 | 12 | 13 | 13 1/4 | - | - | |
| 2 1/2 x 3 - 9 | 3 | 2 1/2 | 33 1/2 | 7 1/8 | 6 | 3 1/2 | 3/8 | 5 | 7 1/2 | 2 3/4 | 5 1/2 | 85 | 10 5/8 | 11 1/4 | 12 1/4 | 12 1/2 | 13 | 13 3/8 | |
| 2 1/2 x 3 - 10 | | | 30 3/4 | 8 7/8 | 7 3/8 | | | | | | | | | | | | | | 9 |
| 3 x 4 - 8 | 4 | 3 | 30 3/16 | 6 1/4 | 5 3/8 | 3 3/4 | 1/4 | 5 5/16 | 7 | 3 | 5 3/8 | 82 | 11 3/16 | 11 13/16 | 12 13/16 | 13 1/16 | 13 3/8 | - | - |
| 3 x 4 - 10 | | | 30 3/8 | 7 3/8 | 6 1/2 | | | 5 1/8 | 7 1/2 | | 5 1/2 | 99 | 11 | 11 3/8 | 12 3/8 | 12 7/8 | - | - | |
| 3 x 4 - 13 | | | 33 3/4 | 9 1/2 | 8 7/8 | | | 5 | 9 | | 7 1/2 | 155 | - | - | 12 1/2 | 12 3/4 | - | - | |
| 4 x 5 - 8 | | | 5 | 34 1/4 | 6 7/8 | | | 5 3/4 | 5 1/2 | | 8 | 5 | 99 | 11 3/8 | 12 | 13 | 13 1/4 | 13 3/4 | 14 3/8 |
| 4 x 6 - 10 | 6 | 4 | 30 3/8 | 8 3/8 | 7 1/2 | 4 1/2 | 3/8 | 5 1/2 | 8 1/2 | 3 3/8 | 7 | 135 | - | - | 13 3/8 | 13 3/8 | - | - | |
| 4 x 6 - 13 | | | 5 1/4 | 9 | 3 | | | 7 1/2 | 171 | - | - | 12 1/2 | 12 3/4 | 13 1/4 | - | | | | |
| 6 x 8 - 13 | | | See Packed Box Dimension Page. (pumps utilize JP motors), Ver la página de dimensiones de la caja empacada. (JP motors) | | | | | | | | | | | | | | | | |
| 8 x 10 - 13 | | | | | | | | | | | | | | | | | | | |
| 4 x 6 - 16 | | | | | | | | | | | | | | | | | | | |

*Denotes NPT connection. All other connections are for use with ANSI class 150 mating flanges. Dimensions in inches, weights in lbs. Do not use for construction purposes.
 * Indica conexión NPT Las demás conexiones deben usarse con bridas de contacto ANSI clase 150.
 Dimensiones en pulgadas, peso en libras. No utilizar para fines de construcción.

Motor Frames and Horsepower
Bastidores del motor y potencia en HP

| Frame Size JM Tamaño del bastidor JM | ODP | TEFC | RPM |
|---|----------|----------|------|
| 143 JM | 1 | 1 | 1750 |
| 145 JM | 1 1/2, 2 | 1 1/2, 2 | |
| 182 JM | 3 | 3 | |
| 184 JM | 5 | 5 | |
| 213 JM | 7 1/2 | 7 1/2 | |
| 215 JM, 215 TCZ | 10 | 10 | |
| 254 JM | 15 | 15 | |
| 256 JM | 20 | 20 | |
| 284 JM | 25 | 25 | |
| 286 JM | 30 | 30 | |
| 324 JM | 40 | 40 | 3500 |
| 326 JM | 50 | 50 | |
| 143 JM | 1 1/2 | 1 1/2 | |
| 145 JM | 2, 3 | 2 | |
| 182 JM | 5 | 3 | |
| 184 JM | 7 1/2 | 5 | |
| 213 JM | 10 | 7 1/2 | |
| 215 JM | 15 | 10 | |
| 215 TCZ | 15 | - | |
| 254 JM | 20 | 15 | |
| 256 JM | 25 | 20 | |
| 284 JM | 30 | 25 | |
| 286 JM | 40 | 30 | |
| 324 JM | 50 | 40 | |
| 326 JM | 60 | 50 | |
| 364 TCZ | 75 | 60 | |
| 365 TCZ | - | 75 | |

Motor Dimensions and Weights (may vary with manufacturer)*
Pesos y dimensiones del motor (pueden variar de acuerdo al fabricante)*

| Motor Frame Bastidor del motor | A | AB (Max.) | B | D | E | F | G | H | P* (Max.) | Weight (lbs.) Pesos (libras) |
|--------------------------------|--------|-----------|--------|-------|-------|-------|------|------|-----------|------------------------------|
| 143JM | 6 1/2 | 5 1/4 | 6 | 3 1/2 | 2 3/4 | 2 | 1/8 | 5/16 | 6 3/8 | 41 |
| 145JM | | | | | | 57 | | | | |
| 182JM | 8 1/2 | 5 3/8 | 6 1/2 | 4 1/2 | 3 3/4 | 2 1/4 | 3/16 | 3/8 | 7 7/8 | 77 |
| 184JM | | | | | | 2 3/4 | 97 | | | |
| 213JM | 9 1/2 | 7 3/8 | 8 | 5 1/4 | 4 1/4 | 2 3/4 | 1/4 | 1/2 | 9 5/8 | 122 |
| 215JM | | | | | | 3 1/2 | 155 | | | |
| 213TCZ | | | | | | 2 3/4 | 122 | | | |
| 215TCZ | | | | | | 3 1/2 | 155 | | | |
| 254JM | 11 1/4 | 9 | 9 1/2 | 6 1/4 | 5 | 4 1/8 | 1/4 | 1/2 | 11 1/2 | 265 |
| 256JM | | | | | | 5 | 320 | | | |
| 284JM | 12 1/4 | 12 1/4 | 10 3/4 | 7 | 5 1/2 | 4 3/4 | 1/4 | 1/2 | 13 1/4 | 419 |
| 286JM | | | | | | 5 1/2 | 422 | | | |
| 324JM | 13 1/4 | 13 1/4 | 12 | 8 | 6 1/4 | 5 1/4 | 3/16 | 5/8 | 15 1/8 | 562 |
| 326JM | | | | | | 6 | 588 | | | |
| 364TCZ | 17 1/2 | 15 1/8 | 14 1/2 | 9 | 7 | 5 5/8 | 1 | 5/8 | 18 3/8 | 775 |
| 365TCZ | | | | | | 6 1/8 | 1005 | | | |

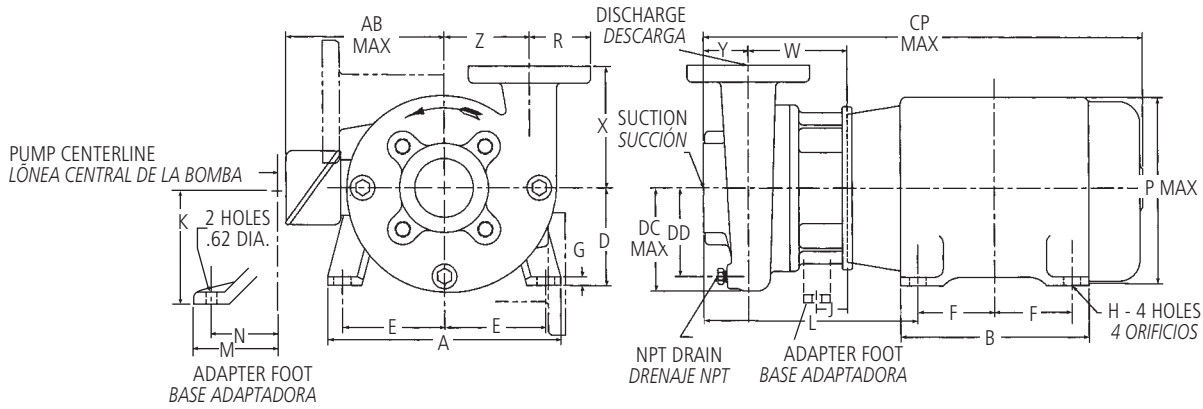

Pump Dimensions and Weights, Peso y dimensiones de la bomba

| Pump Bomba | Suction Succión | Discharge Descarga | CP Max. | DC Max. | DD | J | K | M | N | R | NPT Drain Drenaje NPT | W | X | Y | Z | Wt. (lbs.) Pesos (libras) | Motor Frame, Bastidor del motor | | | | | | | | | | | | | | | | | |
|------------|-----------------|--------------------|---------|---------|-----|----|-----|-----|-----|----|-----------------------|-----|----|----|-----|---------------------------|---------------------------------|---------|-----|-----|-----|-----|---|-----|-----|-----|-----|-----|-----|-----|-----|-----|-----|---|
| | | | | | | | | | | | | | | | | | L | | | | | | | | | | | | | | | | | |
| | | | | | | | | | | | | | | | | | 210 | 250/280 | 320 | 360 | 400 | 440 | | | | | | | | | | | | |
| 1½ x 2 -10 | 2* | 1½* | 34⅞ | 6¾ | 5⅞ | — | — | — | — | 1¼ | ¼ | 7⅞ | 6 | 3 | 5½ | 105 | 16⅞ | 12¾ | — | — | — | — | | | | | | | | | | | | |
| 2½ x 3 -8 | 3* | 2½* | 34⅞ | 6¼ | 5¼ | — | — | — | — | 1⅜ | ¼ | 8 | 6 | 3⅞ | 5 | 90 | 16⅞ | 13¼ | — | — | — | — | | | | | | | | | | | | |
| 2½ x 3 -9 | 3 | 2½ | 37⅞ | 7⅞ | 6 | — | — | — | — | 3½ | ⅜ | 7⅞ | 7½ | 2¾ | 5½ | 95 | 16⅞ | 12½ | 15⅞ | 16½ | — | — | | | | | | | | | | | | |
| 2½ x 3 -10 | | | 34⅞ | 8⅞ | 7⅞ | — | — | — | — | | | | | | | | | | | | | | 9 | 3 | 7½ | 155 | 16⅞ | 12¾ | — | — | — | — | | |
| 2½ x 3 -13 | 4 | 3 | 34⅞ | 6¼ | 5⅞ | — | — | — | — | 3¾ | ¼ | 8⅜ | 7 | 3 | 5⅞ | 90 | 16⅜ | 13⅜ | 16½ | — | — | — | — | | | | | | | | | | | |
| 3 x 4 -8 | | | 34⅞ | 7⅞ | 6½ | — | — | — | — | | | | | | | | | | | | | | | 8 | 7½ | 5½ | 110 | 16½ | 12⅞ | — | — | — | — | |
| 3 x 4 -10 | | | 37⅞ | 9½ | 8⅞ | — | — | — | — | | | | | | | | | | | | | | | 7⅞ | 9 | 7½ | 170 | 16⅞ | 12¾ | — | — | — | — | |
| 3 x 4 -13 | 5 | 3 | 38⅞ | 6⅞ | 5¼ | — | — | — | — | 4½ | ⅜ | 8⅞ | 8 | 5 | 110 | 16⅞ | 13¼ | 16⅞ | 17¼ | — | — | — | — | | | | | | | | | | | |
| 4 x 5 -8 | | | 34⅞ | 8⅞ | 7½ | — | — | — | — | | | | | | | | | | | | | | | 8⅞ | 8½ | 3⅞ | 7 | 145 | 17 | 13⅞ | — | — | — | |
| 4 x 6 -10 | 6 | 4 | 35⅞ | 9¼ | 8⅞ | — | — | — | — | 4½ | ⅜ | 8⅞ | 9 | 3 | 7½ | 185 | 16⅞ | 12¾ | 16⅞ | — | — | — | — | | | | | | | | | | | |
| 4 x 6 -13 | | | 47⅞ | 12¾ | 11 | 1⅜ | 9¾ | 8 | 7 | | | | | | | | | | | | | | | 8⅞ | 12 | 4 | 10½ | 390 | 16⅜ | 17⅜ | 17⅜ | 18⅞ | 19¼ | — |
| 4 x 6 -16 | | | 8⅞ | 11 | 3 | 8¼ | 290 | 16¾ | 17¼ | | | | | | | | | | | | | | | 17¾ | 18⅞ | 18⅞ | 19¼ | — | | | | | | |
| 6 x 8 -13 | 8 | 6 | 45⅞ | 12¾ | 10½ | 2⅞ | 7½ | 6½ | 5½ | 5½ | 8⅞ | 11 | 3 | 8¼ | 290 | 16¾ | 17¼ | 17¾ | 18⅞ | 18⅞ | 19¼ | — | | | | | | | | | | | | |
| 8 x 10 -13 | 10 | 8 | 48⅞ | 14¾ | 13 | 2⅞ | 7½ | 6½ | 5½ | 6¼ | 8⅞ | 12¾ | 4 | 10 | 520 | 17⅞ | 17⅞ | 18⅞ | 18¼ | 19¼ | 20⅞ | — | | | | | | | | | | | | |

*Denotes NPT connection. All other connections are for use with ANSI class 150 mating flanges.

* Indica conexión NPT Las demás conexiones deben usarse con bridas de contacto ANSI clase 150.

■ Indicates "L" Group pump (dimensions valid for packed box or mechanical seal), ■ Indica una bomba Grupo "L" (dimensiones válidas para caja empacada o sella mecánico).

Motor Dimensions and Weights (may vary with manufacturer)*, Peso y dimensiones del motor (pueden variar de acuerdo al fabricante) *

| Motor Frame Bastidor del motor | A | AB Max. | B | D | E | F | G | H | P Max. | Horsepower | | | | | | | | Wt. Max. |
|--------------------------------|-----|---------|-----|----|----|----|---|----|--------|------------|------|---------|---------|----------|------|---------|------|----------|
| | | | | | | | | | | 3500 RPM | | | | 1750 RPM | | | | |
| | | | | | | | | | | 1 Phase | | 3 Phase | | 1 Phase | | 3 Phase | | |
| | | | | | | | | | | ODP | TEFC | ODP | TEFC | ODP | TEFC | ODP | TEFC | |
| 213JP | 9½ | 7⅞ | 8 | 5¼ | 4¼ | 2¾ | ¼ | 1⅜ | 9⅞ | 7½ | — | 10 | — | 5 | — | 7½ | 7½ | 125 |
| 3½ | | | | | | 10 | | | | — | 15 | 10 & 15 | 7½ & 10 | — | 10 | 10 | 155 | |
| 254JP | 11¼ | 9 | 11¾ | 6¼ | 5 | 4⅞ | ¼ | 1⅞ | 11½ | — | — | 20 | — | — | — | 15 | 15 | 255 |
| 5 | | | | | | — | | | | — | 25 | 20 | — | — | 20 | 20 | 280 | |
| 284JP | 12¼ | 12¼ | 12¼ | 7 | 5½ | 4¾ | ¼ | 1⅞ | 13¼ | — | — | 30 | 25 | — | — | 25 | 25 | 410 |
| 5½ | | | | | | — | | | | — | 40 | 30 | — | — | 30 | 30 | 425 | |
| 324JP | 13¼ | 13¼ | 13½ | 8 | 6¼ | 5¼ | ⅝ | 2½ | 15⅞ | — | — | 50 | 40 | — | — | 40 | 40 | 560 |
| 6 | | | | | | — | | | | — | 60 | 50 | — | — | 50 | 50 | 590 | |
| 364TCZ | 17½ | 14⅞ | 15⅞ | 9 | 7 | 5⅞ | 1 | 2½ | 18⅞ | — | — | 75 | 60 & 75 | — | — | 60 | 60 | 775 |
| 6⅞ | | | | | | — | | | | — | — | — | — | 75 | 75 | 1005 | | |
| 404TCZ | 19½ | 17½ | 16⅞ | 10 | 8 | 6⅞ | 1 | 1⅝ | 20⅞ | — | — | — | — | — | — | 100 | 100 | 1110 |
| 6⅞ | | | | | | — | | | | — | — | — | — | 125 | — | 1163 | | |
| 444TCZ | 21½ | 19⅞ | 19½ | 11 | 9 | 7¼ | 1 | 1⅝ | 22½ | — | — | — | — | — | — | 150 | 125 | 1600 |
| 8¼ | | | | | | — | | | | — | — | — | — | 150 | 150 | 1708 | | |

NOTE:

- All pumps shipped in vertical discharge position. For other orientations, remove casing bolts, rotate to desired position, and tighten ⅜ - 16 casing bolts to 37 ft./

- lbs. torque., ½ - 13 casing bolts to 90 ft./lbs. torque.
- Dimensions in inches, weight in pounds.
- Not to be used for construction purposes.

NOTA:

- Todas las bombas se embarcan con la descarga en posición vertical. Para otras orientaciones, retire los pernos de la carcasa, haga rotar la descarga hasta la posición deseada y ajuste los 16 pernos

- de ⅜ de pulgada a una torsión de 37 pies/libra, y los 13 pernos de ½ pulgada a 90 pies/libra.
- Dimensiones en pulgadas, peso en libras.
- No utilizar con fines de construcción.

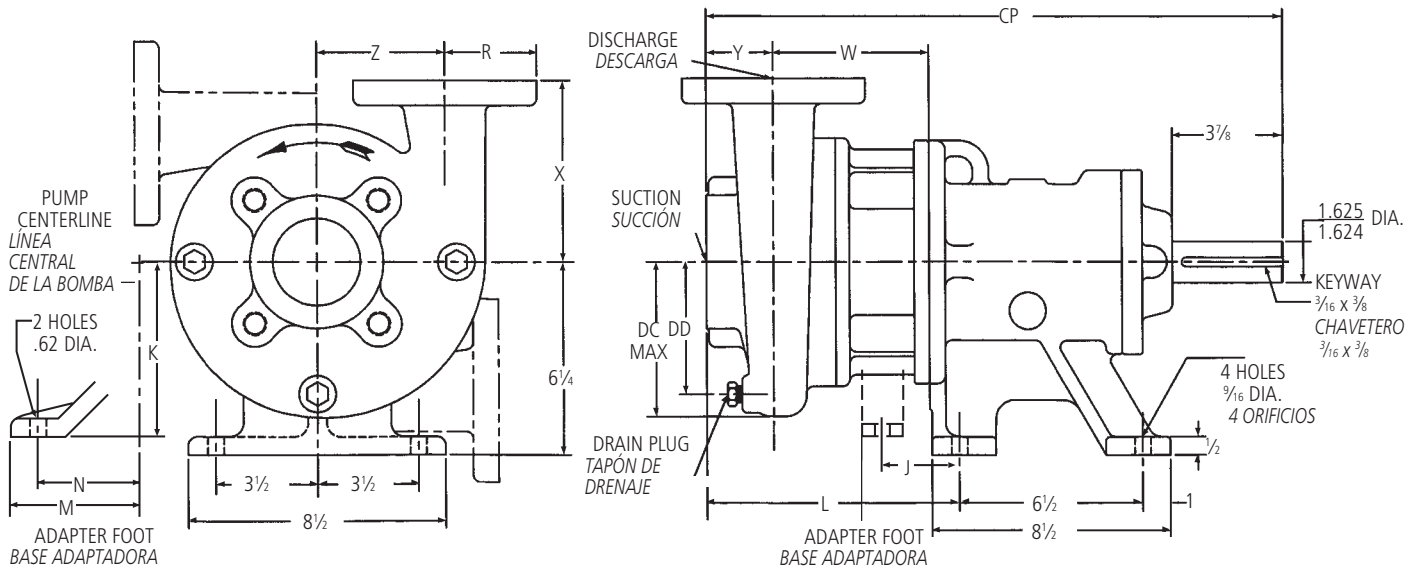

Motor Dimensions and Weights (may vary with manufacturer)*
Pesos y dimensiones del motor (pueden variar de acuerdo al fabricante)*

| Pump Bomba | Suction Succión | Discharge Descarga | CP | DC (Max.) | DD | L | J | K | M | N | R | NPT Drain Drenaje NPT | W | X | Y | Z | Weight (lbs.) Pesos (libras) | | |
|----------------|-----------------|--------------------|---------|-----------|--------|----------|--------|-------|-------|-------|---------|-----------------------|--------|-------|-------|-------|------------------------------|-------|--------|
| 1 1/2 x 2 - 10 | 2* | 1 1/2* | 2 1/8 | 6 3/4 | 5 7/8 | 9 3/8 | — | — | — | — | 1 1/4 | 1/4 | 5 | 6 | 3 | 5 1/2 | 155 | | |
| 2 1/2 x 3 - 8 | 3* | 2 1/2* | 2 3/8 | 6 1/4 | 5 1/4 | 9 7/8 | — | — | — | — | 1 13/16 | | 5 7/8 | | | | 3 3/8 | 5 | 140 |
| 2 1/2 x 3 - 9 | 3 | 2 1/2 | 2 1/8 | 7 1/8 | 6 | 9 7/8 | — | — | — | — | 3 1/2 | 3/8 | 5 | 7 1/2 | 2 3/4 | 5 1/2 | 147 | | |
| 2 1/2 x 3 - 13 | | | 2 1/8 | 8 7/8 | 7 3/8 | 9 3/8 | — | — | — | — | | | | | | | — | 9 | 3 |
| 3 x 4 - 8 | 4 | 3 | 2 3/16 | 6 1/4 | 5 3/8 | 9 1/16 | — | — | — | — | 3 3/4 | 1/4 | 5 5/16 | 7 | 3 | 5 5/8 | 144 | | |
| 3 x 4 - 10 | | | 22 | 7 3/8 | 6 1/2 | 9 1/2 | — | — | — | — | | | 5 5/8 | | | | 7 1/2 | 5 1/2 | 161 |
| 3 x 4 - 13 | | | 2 1/8 | 9 1/2 | 8 7/8 | 9 3/8 | — | — | — | — | | | 5 | | | | 9 | 7 1/2 | 217 |
| 4 x 5 - 8 | 5 | 4 | 2 3/8 | 6 7/8 | 5 3/4 | 9 7/8 | — | — | — | — | 4 1/2 | 3/8 | 5 1/2 | 8 | 3 | 5 | 161 | | |
| 4 x 6 - 10 | | | 2 2 1/2 | 8 3/8 | 7 1/2 | 10 | — | — | — | — | | | 5 1/2 | | | | 8 1/2 | 3 3/8 | 7 |
| 4 x 6 - 13 | 6 | 4 | 2 2 1/8 | 9 3/4 | 8 7/8 | 9 3/8 | — | — | — | — | 5 1/2 | 3/8 | 5 3/4 | 9 | 3 | 7 1/2 | 233 | | |
| ■ 4 x 6 - 16 | | | 2 6 1/2 | 12 3/4 | 11 | 12 13/16 | 2 9/16 | 9 3/4 | 8 | 7 | | | 8 3/8 | | | | 12 | 4 | 10 1/2 |
| ■ 6 x 8 - 13 | 8 | 6 | 2 5 1/4 | 12 3/4 | 10 1/2 | 13 3/8 | 3 3/4 | 7 1/2 | 6 1/2 | 5 1/2 | 5 1/2 | 3/8 | 8 3/8 | 11 | 3 | 8 3/4 | 330 | | |
| ■ 8 x 10 - 13 | | | 2 6 1/2 | 14 3/4 | 13 | 14 | 3 3/4 | 7 1/2 | 6 1/2 | 5 1/2 | 6 3/4 | | 8 3/8 | | | | 12 3/4 | 4 | 10 |

*Denotes NPT connection. All other connections are for use with ANSI class 150 mating flanges.

Dimensions in inches, weights in lbs. Do not use for construction purposes.

* Indica conexión NPT Las demás conexiones deben usarse con bridas de contacto ANSI clase 150.

Dimensiones en pulgadas, peso en libras. No utilizar para fines de construcción.

■ Indicates "L" Group pump., ■ Indica una bomba Grupo "L".

NOTE:

- All pumps shipped in vertical discharge position. For other orientations, remove casing bolts, rotate to desired position, and tighten 3/8 - 16 casing bolts to 37 ft./lbs. torque., 1/2 - 13 casing bolts to 90 ft./lbs. torque.
- Dimensions in inches, weight in pounds.
- Not to be used for construction purposes.

NOTA:

- Todas las bombas se embarcan con la descarga en posición vertical. Para otras orientaciones, retire los pernos de la carcasa, haga rotar la descarga hasta la posición deseada y ajuste los 16 pernos de 3/8 de pulgada a una torsión de 37 pies/libra, y los 13 pernos de 1/2 pulgada a 90 pies/libra.
- Dimensiones en pulgadas, peso en libras.
- No utilizar con fines de construcción.

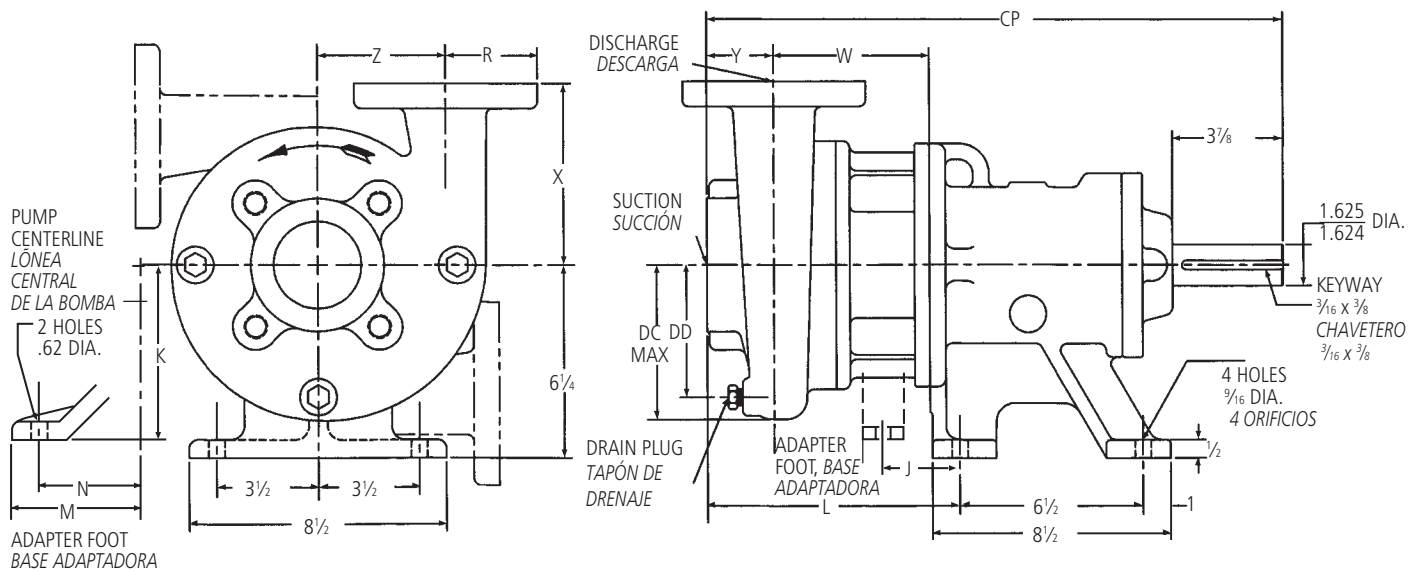

Motor Dimensions and Weights (may vary with manufacturer)*
Pesos y dimensiones del motor (pueden variar de acuerdo al fabricante)*

| Pump Bomba | Suction Succión | Discharge Descarga | CP | DC (Max.) | DD | L | J | K | M | N | R | NPT Drain Drenaje NPT | W | X | Y | Z | Weight (lbs.) Pesos (libras) | |
|----------------|-----------------|--------------------|---------|-----------|----------|---------|-------|-------|-------|-------|---------|-----------------------|--------|-------|-------|-------|------------------------------|-----|
| 1 1/2 x 2 - 10 | 2* | 1 1/2* | 24 3/4 | 6 3/4 | 5 7/8 | 12 1/4 | — | — | — | — | 1 1/4 | 1/4 | 7 7/8 | 6 | 3 | 5 1/2 | 165 | |
| 2 1/2 x 3 - 8 | 3* | 2 1/2* | 25 1/4 | 6 1/4 | 5 1/4 | 12 3/4 | — | — | — | — | 1 13/16 | | 8 | | 3 3/8 | 5 | 150 | |
| 2 1/2 x 3 - 9 | 3 | 2 1/2 | 24 1/2 | 7 1/8 | 6 | 12 | — | — | — | — | 3 1/2 | 3/8 | 7 7/8 | 7 1/2 | 2 3/4 | 5 1/2 | 160 | |
| 2 1/2 x 3 - 13 | | | 24 3/4 | 8 7/8 | 7 3/8 | 12 1/4 | — | — | — | — | — | | — | 9 | 3 | 7 1/2 | 215 | |
| 3 x 4 - 8 | 4 | 3 | 22 1/16 | 6 1/4 | 5 3/8 | 12 3/16 | — | — | — | — | — | 1/4 | 8 3/16 | 7 | 3 | 5 5/8 | 155 | |
| 3 x 4 - 10 | | | 24 7/8 | 7 3/8 | 6 1/2 | 12 3/8 | — | — | — | — | 3 3/4 | | 8 | 7 1/2 | | 5 1/2 | 170 | |
| 3 x 4 - 13 | | | 24 3/4 | 9 1/2 | 8 1/8 | 12 1/4 | — | — | — | — | — | | — | 7 7/8 | | 9 | 7 1/2 | 230 |
| 4 x 5 - 8 | 5 | 4 | 25 1/4 | 6 1/8 | 5 3/4 | 12 3/4 | — | — | — | — | — | 3/8 | 8 3/8 | 8 | 3 | 5 | 170 | |
| 4 x 6 - 10 | 25 3/8 | | 8 3/8 | 7 1/2 | 12 7/8 | — | — | — | — | — | — | | 8 3/8 | 8 1/2 | | 3 3/8 | 7 | 210 |
| 4 x 6 - 13 | 25 | | 9 3/4 | 8 1/8 | 12 1/2 | — | — | — | — | — | — | | 8 3/8 | 9 | | 3 | 7 1/2 | 245 |
| ■ 4 x 6 - 16 | 26 1/2 | | 12 3/4 | 11 | 12 13/16 | 2 9/16 | 9 3/4 | 8 | 7 | — | — | | 8 3/8 | 12 | | 4 | 10 1/2 | 430 |
| ■ 6 x 8 - 13 | 8 | 6 | 25 1/4 | 12 3/4 | 10 1/2 | 13 3/8 | 3 3/4 | 7 1/2 | 6 1/2 | 5 1/2 | 5 1/2 | 8 3/8 | 11 | 3 | 8 3/4 | 330 | | |
| ■ 8 x 10 - 13 | 10 | 8 | 26 1/2 | 14 3/4 | 13 | 14 | 3 3/4 | 7 1/2 | 6 1/2 | 5 1/2 | 6 3/4 | 8 3/8 | 12 3/4 | 4 | 10 | 515 | | |

■ Indicates "L" Group pump., ■ Indica una bomba Grupo "L".

NOTE:

- All pumps shipped in vertical discharge position. For other orientations, remove casing bolts, rotate to desired position, and tighten 3/8 - 16 casing bolts to 37 ft./lbs. torque., 1/2 - 13 casing bolts to 90 ft./lbs. torque.
- Dimensions in inches, weight in pounds.
- Not to be used for construction purposes.

NOTA:

- Todas las bombas se embarcan con la descarga en posición vertical. Para otras orientaciones, retire los pernos de la carcasa, haga rotar la descarga hasta la posición deseada y ajuste los 16 pernos de 3/8 de pulgada a una torsión de 37 pies/libra, y los 13 pernos de 1/2 pulgada a 90 pies/libra.
- Dimensiones en pulgadas, peso en libras.
- No utilizar con fines de construcción.

Channel Steel Bedplate. Clockwise rotation viewed from drive end.

Placa de asiento de acero acanalado. Rotación dextrorsa (sentido de las agujas del reloj) cuando se mira desde el extremo del motor.

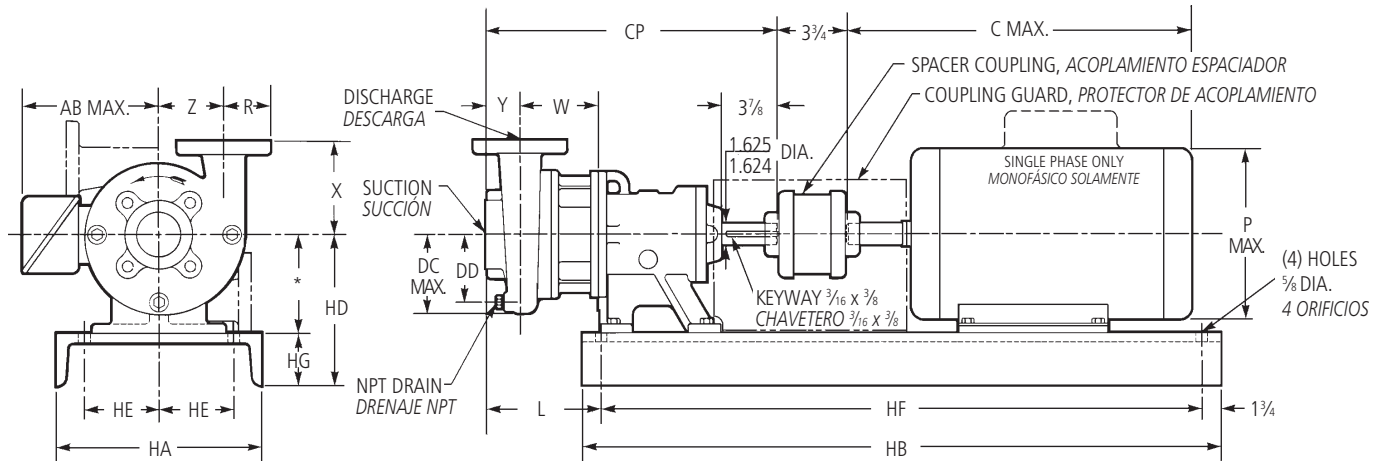

* Dimension will include any special shims required to match pump centerline to motor.

* La dimensión incluye cualquier cuña especial que se requiera para hacer coincidir la línea central de la bomba con el motor.

Pump Dimensions and Weights

Peso y dimensiones de la bomba

| Pump Bomba | Suction Succión | Discharge Descarga | CP Max. | DC Max. | DD | L | R | NPT Drain Drenaje NPT | W | X | Y | Z | Weight (lbs) Pesos (libras) | | | |
|-------------|-----------------|--------------------|---------|---------|----|----|----|-----------------------|----|----|----|----|-----------------------------|-----|----|-----|
| 1½ x 2 – 10 | 2* | 1½* | 21⅞ | 6¾ | 5⅞ | 9⅞ | 1¼ | 1¼ | 5 | 6 | 3 | 5½ | 155 | | | |
| 2½ x 3 – 8 | 3* | 2½* | 22⅜ | 6¼ | 5¼ | 9⅞ | 1⅜ | | 5⅞ | | | | 5 | 140 | | |
| 2½ x 3 – 9 | 3 | 2½ | 21⅞ | 7⅞ | 6 | 9⅞ | 3½ | ¾ | 5 | 7½ | 2¾ | 5½ | 147 | | | |
| 2½ x 3 – 10 | | | 21⅞ | 8⅞ | 7⅞ | 9⅞ | | | | | | | 9 | 3 | 7½ | 201 |
| 2½ x 3 – 13 | | | 22⅜ | 6¼ | 5⅞ | 9⅞ | | | | | | | 5 | 3 | 7½ | 201 |
| 3 x 4 – 8 | 4 | 3 | 22⅜ | 6¼ | 5⅞ | 9⅞ | 3¾ | ¼ | 5⅞ | 7 | 3 | 5½ | 144 | | | |
| 3 x 4 – 10 | | | 22 | 7⅞ | 6½ | 9⅞ | | | 5⅞ | 7½ | | 5½ | 161 | | | |
| 3 x 4 – 13 | | | 21⅞ | 9½ | 8⅞ | 9⅞ | | | 5 | 9 | | 7½ | 217 | | | |
| 4 x 5 – 8 | | | 22⅜ | 6⅞ | 5¾ | 9⅞ | | | 5½ | 8 | | 5 | 161 | | | |
| 4 x 6 – 10 | 6 | 4 | 22½ | 8⅞ | 7½ | 10 | 4½ | ¾ | 5½ | 8½ | 3⅞ | 7 | 200 | | | |
| 4 x 6 – 13 | | | 22⅞ | 9¼ | 8⅞ | 9⅞ | | | 5¼ | 9 | 3 | 7½ | 233 | | | |

*Denotes NPT connection. All other connections are for use with ANSI class 150 mating flanges.

* Indica conexión NPT Las demás conexiones deben usarse con bridas de contacto ANSI clase 150.

Motor and Bedplate Dimensions and Weights (may vary with manufacturer.)

Peso y dimensiones del motor y la placa de asiento (pueden variar de acuerdo al fabricante)

| Motor Frame Bastidor del motor | HP @ 3500 RPM | | HP @ 1750 RPM - T-Frame Only, Bastidor T únicamente | | AB Max. | C Max. | P Max. | Wt. (lbs.) Pesos (libras) | Bedplate Data, Datos de la placa de asiento | | | | | | | Weight (lbs) Pesos (libras) | Motor Shim Cuña del motor | Bearing Frame Shim, Cuña del bastidor de cojinetes |
|--------------------------------|------------------------|------|---|------|---------|--------|--------|---------------------------|---|----|-----|----|-----|----|-----|-----------------------------|---------------------------|--|
| | Three phase, Trifásico | | | | | | | | HA | HB | HD | HE | HF | HG | | | | |
| | ODP | TEFC | ODP | TEFC | | | | | | | | | | | | | | |
| 184T | — | — | 5 | 5 | 5⅞ | 18 | 8 | 95 | 13 | 42 | 10¼ | 5¼ | 38½ | 4 | 111 | 1¼ | — | |
| 213T | — | — | 7½ | 7½ | 7⅞ | 18 | 9⅞ | 116 | | | | | | | | | | |
| 215T | 15 | — | 10 | 10 | 10⅞ | 19⅞ | 13 | 136 | | | | | | | | | | |
| 254T | 20 | 15 | 15 | 15 | 10⅞ | 21⅞ | 13 | 266 | 15 | 44 | 10½ | 5¾ | 40½ | 3½ | 124 | — | ¾ | |
| 256T | 25 | 20 | 20 | 20 | 12⅞ | 23⅞ | 15 | 264 | | | | | | | | | | |
| 284TS/T | 30 | 25 | 25 | 25 | 12⅞ | 24⅞ | 15 | 392 | | | | | | | | | | |
| 286TS/T | 40 | 30 | 30 | 30 | 12⅞ | 26⅞ | 15 | 422 | 18 | 48 | 12 | 7¼ | 44½ | 4 | 183 | — | 1¾ | |
| 324TS/T | 50 | 40 | 40 | 40 | 14⅞ | 28¾ | 17⅞ | 592 | | | | | | | | | | |
| 326TS/T | 60 | 50 | 50 | 50 | 14⅞ | 30¼ | 17⅞ | 634 | | | | | | | | | | |
| 364TS/T | 75 | 60 | 60 | 60 | 15⅞ | 31⅞ | 18⅞ | 834 | 13 | — | — | — | — | — | — | — | 2¾ | |
| 356TS/T | 100 | 75 | 75 | 75 | 15⅞ | 32⅞ | 18⅞ | 1000 | | | | | | | | | | |

NOTE:

- All pumps shipped in vertical discharge position. For other orientations, remove casing bolts, rotate to desired position, and tighten ¾ - 16 casing bolts to 37 ft./lbs. torque., ½ - 13 casing bolts to 90 ft./lbs. torque.
- Dimensions in inches, weight in pounds.
- Not to be used for construction purposes.

NOTA: 1. Todas las bombas se embarcan con la descarga en posición vertical. Para otras orientaciones, retire los pernos de la carcasa, haga rotar la descarga hasta la posición deseada y ajuste los 16 pernos de ¾ de pulgada a una torsión de 37 pies/libra, y los 13 pernos de ½ pulgada a 90 pies/libra.

2. Dimensiones en pulgadas, peso en libras.

3. No utilizar con fines de construcción.

Channel Steel Bedplate. Clockwise rotation viewed from drive end.

Placa de asiento de acero acanalado. Rotación dextrorsa (sentido de las agujas del reloj) cuando se mira desde el extremo del motor.

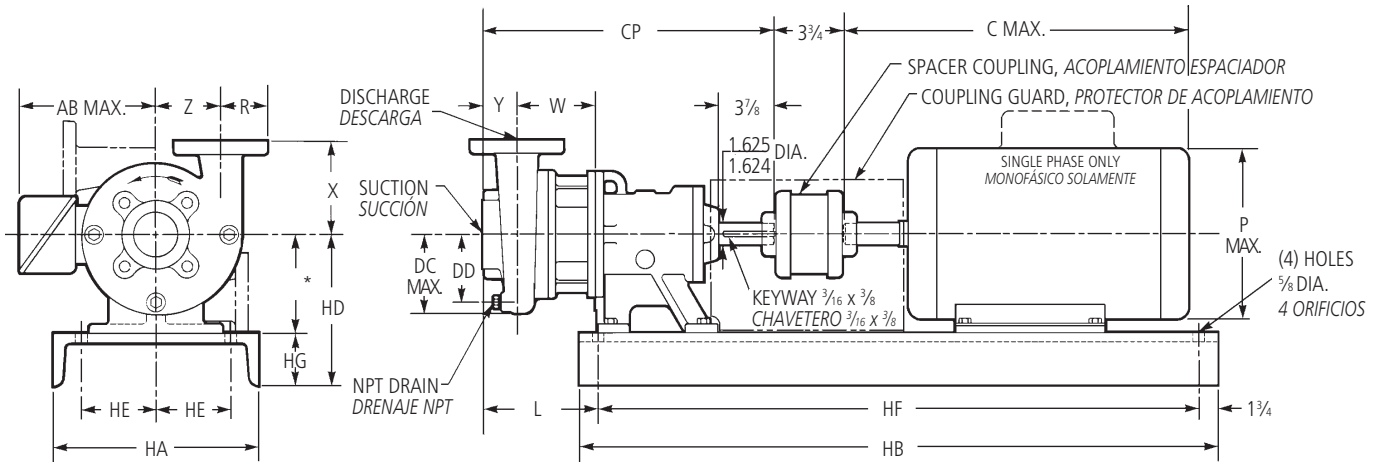

* Dimension will include any special shims required to match pump centerline to motor.

* La dimensión incluye cualquier cuña especial que se requiera para hacer coincidir la línea central de la bomba con el motor.

Pump Dimensions and Weights
Peso y dimensiones de la bomba

| Pump Bomba | Suction Succión | Discharge Descarga | CP Max. | DC Max. | DD | L | R | NPT Drain Drenaje NPT | W | X | Y | Z | Weight (lbs) Pesos (libras) | |
|-------------|-----------------|--------------------|---------|---------|----|-----|----|-----------------------|----|----|----|-----|-----------------------------|-----|
| 1½ x 2 – 10 | 2* | 1½* | 24¾ | 6¼ | 5⅝ | 12¼ | 1¼ | ¼ | 7⅞ | 6 | 3 | 5½ | 165 | |
| 2½ x 3 – 8 | 3* | 2½* | 25¼ | 6¼ | 5¼ | 12¾ | 1⅜ | | 8 | | | | | 3⅜ |
| 2½ x 3 – 9 | 3 | 2½ | 24½ | 7⅞ | 6 | 12 | 3½ | ⅜ | 7⅞ | 2¾ | 5½ | 160 | | |
| 2½ x 3 – 10 | | | 24¾ | 8⅞ | 7⅞ | 12¼ | | | 9 | | | | 3 | 7½ |
| 3 x 4 – 8 | 4 | 3 | 22⅞ | 6¼ | 5⅝ | 12⅜ | 3¾ | ¼ | 8⅞ | 7 | 3 | 5⅝ | 155 | |
| 3 x 4 – 10 | | | 24⅞ | 7⅞ | 6½ | 12⅜ | | | 8 | | | 7½ | 5½ | 170 |
| 3 x 4 – 13 | | | 24¾ | 9½ | 8⅞ | 12¼ | | | 7⅞ | | | 9 | 7½ | 230 |
| 4 x 5 – 8 | 5 | 4 | 25¼ | 6⅞ | 5¾ | 12¾ | 4½ | ⅜ | 8⅞ | 8 | 3 | 5 | 170 | |
| 4 x 6 – 10 | | | 25⅞ | 8⅞ | 7½ | 12⅞ | | | 8½ | | | 3⅞ | 7 | 210 |
| 4 x 6 – 13 | 6 | | 25 | 9¾ | 8⅞ | 12½ | | | 8⅞ | 9 | 3 | 7½ | 245 | |

*Denotes NPT connection. All other connections are for use with ANSI class 150 mating flanges.

* Indica conexión NPT Las demás conexiones deben usarse con bridas de contacto ANSI clase 150.

Motor and Bedplate Dimensions and Weights (may vary with manufacturer.)

Peso y dimensiones del motor y la placa de asiento (pueden variar de acuerdo al fabricante)

| Motor Frame Bastidor del motor | HP @ 3500 RPM | | HP @ 1750 RPM - T-Frame Only, Bastidor T únicamente | | AB Max. | C Max. | P Max. | Wt. (lbs.) Pesos (libras) | Bedplate Data, Datos de la placa de asiento | | | | | | | Weight (lbs) Pesos (libras) | Motor Shim Cuña del motor | Bearing Frame Shim, Cuña del bastidor de cojinetes |
|--------------------------------|------------------------|------|---|------|---------|--------|--------|---------------------------|---|----|-----|----|-----|----|-----|-----------------------------|---------------------------|--|
| | Three phase, Trifásico | | | | | | | | HA | HB | HD | HE | HF | HG | | | | |
| | ODP | TEFC | ODP | TEFC | | | | | | | | | | | | | | |
| 184T | — | — | 5 | 5 | 5⅞ | 18 | 8 | 95 | 13 | 42 | 10¼ | 5¼ | 38½ | 4 | 111 | — | 1¾ | |
| 213T | — | — | 7½ | 7½ | 7⅞ | 18 | 9⅞ | 116 | | | | | | | | | 1 | |
| 215T | 15 | — | 10 | 10 | 19⅞ | 19⅞ | 13 | 136 | | | | | | | | | — | |
| 254T | 20 | 15 | 15 | 15 | 10½ | 21⅞ | 13 | 266 | — | — | | | | | | | | |
| 256T | 25 | 20 | 20 | 20 | 10½ | 23⅞ | 15 | 264 | — | — | | | | | | | | |
| 284TS/T | 30 | 25 | 25 | 25 | 12⅞ | 24⅞ | 15 | 392 | 15 | 44 | 10½ | 5¾ | 40½ | 3½ | 124 | — | ¾ | |
| 286TS/T | 40 | 30 | 30 | 30 | 12⅞ | 26⅞ | 15 | 422 | 18 | 48 | 12 | 7¼ | 44½ | 4 | 183 | — | 1¾ | |
| 324TS/T | 50 | 40 | 40 | 40 | 14⅞ | 28¾ | 17⅞ | 592 | | | | | | | | | — | |
| 326TS/T | 60 | 50 | 50 | 50 | 14⅞ | 30¼ | 17⅞ | 634 | | | | | | | | | — | |
| 364TS/T | 75 | 60 | 60 | 60 | 15⅞ | 31⅞ | 18⅞ | 834 | 13 | 13 | 13 | 7¼ | 44½ | 4 | 183 | — | 2¾ | |
| 356TS/T | 100 | 75 | 75 | 75 | | 32⅞ | 18⅞ | 1000 | | | | | | | | | — | |

NOTE:

- All pumps shipped in vertical discharge position. For other orientations, remove casing bolts, rotate to desired position, and tighten ⅜ - 16 casing bolts to 37 ft./lbs. torque, ½ - 13 casing bolts to 90 ft./lbs. torque.
- Dimensions in inches, weight in pounds.
- Not to be used for construction purposes.

NOTA: 1. Todas las bombas se embarcan con la descarga en posición vertical. Para otras orientaciones, retire los pernos de la carcasa, haga rotar la descarga hasta la posición deseada y ajuste los 16 pernos de ⅜ de pulgada a una torsión de 37 pies/libra, y los 13 pernos de ½ pulgada a 90 pies/libra.

- Dimensiones en pulgadas, peso en libras.
- No utilizar con fines de construcción

Channel Steel Bedplate. Clockwise rotation viewed from drive end.

Placa de asiento de acero acanalado. Rotación dextrorsa (sentido de las agujas del reloj) cuando se mira desde el extremo del motor.

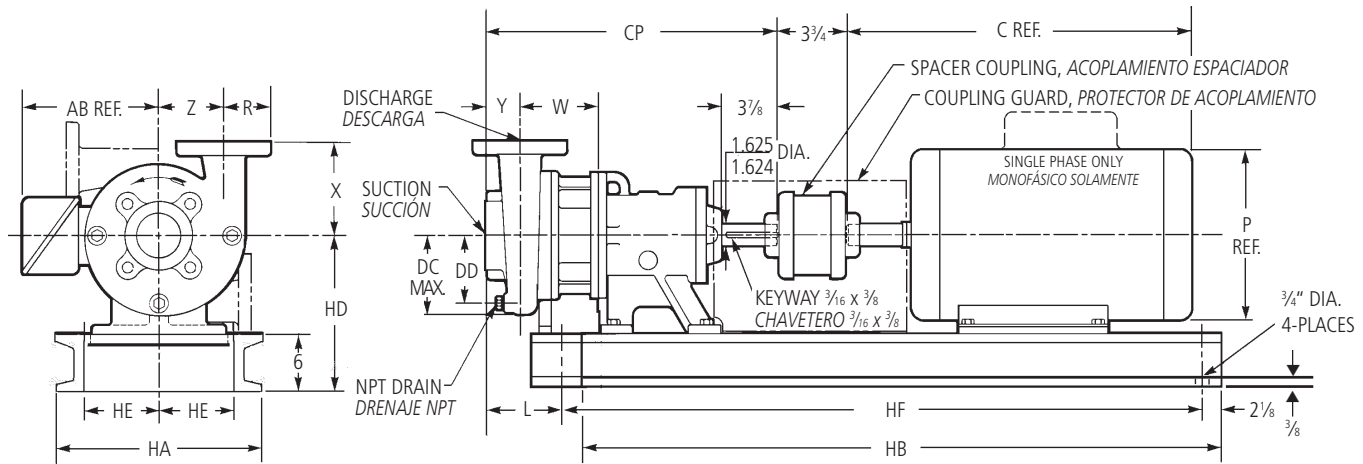

Dimensions and Weights, Pesos y dimensiones

| Pump, Bomba | Size, Tamaño | Suction, Succión | Discharge, Descarga | CP | DC Max. | DD | L | R | W | X | Y | Z |
|-------------|--------------|------------------|---------------------|--------|---------|--------|----------|-------|-------|--------|---|--------|
| 18BF | 6 x 8-13 | 8 | 6 | 25 1/4 | 12 3/4 | 10 1/2 | 13 3/8 | 5 1/2 | 8 3/8 | 11 | 3 | 8 3/4 |
| 19BF | 8 x 10-13 | 10 | 8 | 26 1/2 | 14 3/4 | 13 | 14 | 6 3/4 | 8 3/8 | 12 3/4 | 4 | 10 |
| 20BF | 4 x 6-16 | 6 | 4 | 26 1/2 | 12 3/4 | 11 | 12 13/16 | 4 1/2 | 8 3/8 | 12 | 4 | 10 1/2 |

Motor and Bedplate Dimensions and Weights, Peso y dimensiones del motor y la placa de asiento

| Pump Size, Tamaño de Bomba | Motor Frame, Bastidor del motor | Motor Data | | | | | | | | Baseplate Data | | | | | | | | | | | | | |
|----------------------------|---------------------------------|------------------------|----------|----------|---------|---------------|--------|--------|------|--|------------|------------|------------|-------------|-------------|-----------------------------|---|-------|--|--|--|--|-----|
| | | HP @ 3500 RPM | | | | HP @ 1750 RPM | | | | Weight (lbs) Ref., Pesos (libras) Ref. | HA +/- 1/4 | HB +/- 1/4 | HD +/- 1/8 | HE +/- 1/16 | HF +/- 1/16 | Weight (lb), Pesos (libras) | Shim Height Under Motor Shim Height Under Motor | | | | | | |
| | | Three Phase, Trifásica | | | | AB Ref. | C Ref. | P Ref. | Open | | | | | | | | | Encl. | | | | | |
| | | ODP | TEFC | ODP | TEFC | | | | | | | | | | | | | | | | | | |
| 18BF | 324T/326T | | | 40, 50 | 40, 50 | 14.13 | 30 | 16.50 | 440 | 580 | 29.06 | 48 | 15.75 | 13.66 | 43.75 | 244 | 1" | | | | | | |
| | 324TS/325TS | 50, 60 | 40, 50 | | | | 29 | | 4810 | 520 | | | | | | | | | | | | | N/A |
| | 364T/365T | | | 60, 75 | 60, 75 | 15.06 | 34 | 18.25 | 665 | 835 | | | | | | | | | | | | | |
| | 364TS/365TS | 75, 100 | 60, 75 | | | | 32 | | 730 | 820 | | | | | | | | | | | | | |
| | 404TS/405TS | 125, 150 | 100 | | | 18 | 36 | 20.13 | 950 | 1150 | | | | | | | | | | | | | |
| | 404T/405T | | | 100, 125 | 100 | | 39 | | 930 | 1160 | | | | | | | | 1" | | | | | |
| | 444TS/445TS | 200-300 | 125, 150 | | | 19.56 | 41 | 22.38 | 1250 | 1615 | | | | | | | | | | | | | |
| | 444T/445T | | | 150-300 | 125-200 | | 45 | | 1370 | 1650 | | | | | | | | | | | | | |
| | 447TS | 350 | 200 | | | 21.69 | 47 | | 1800 | 2550 | | 60.25 | | | 56 | 345 | | N/A | | | | | |
| | 449TS | 400-450 | 250-400 | | | | 51 | 23.75 | 1850 | 2550 | | | | | | | | | | | | | |
| 447T | | | 350 | 250 | | 48 | | 1800 | 2260 | | | | | | | | | | | | | | |
| 19BF | 324T/326T | | | 40, 50 | 40, 50 | 14.13 | 30 | 16.50 | 440 | 580 | 29.06 | 48 | 15.75 | 13.66 | 43.75 | 244 | 1" | | | | | | |
| | 324TS/325TS | 50, 60 | 40, 50 | | | | 29 | | 4810 | 520 | | | | | | | | | | | | | |
| | 364T/365T | | | 60, 75 | 60, 75 | 15.06 | 34 | 18.25 | 665 | 835 | | | | | | | | | | | | | |
| | 364TS/365TS | 75, 100 | 60, 75 | | | | 32 | | 730 | 820 | | | | | | | | | | | | | |
| | 404TS/405TS | 125, 150 | 100 | | | 18 | 36 | 20.13 | 950 | 1150 | | | | | | | | | | | | | |
| | 404T/405T | | | 100, 125 | 100 | | 39 | | 930 | 1160 | | | | | | | | 1" | | | | | |
| | 444TS/445TS | 200-300 | 125, 150 | | | 19.56 | 41 | 22.38 | 1250 | 1615 | | | | | | | | | | | | | |
| | 444T/445T | | | 150-300 | 125-200 | | 45 | | 1370 | 1650 | | | | | | | | | | | | | |
| | 447TS | 350 | 200 | | | 21.69 | 47 | | 1800 | 2550 | | 60.25 | | | 56 | 345 | | N/A | | | | | |
| | 449TS | 400-450 | 250-400 | | | | 51 | 23.75 | 1850 | 2550 | | | | | | | | | | | | | |
| 447T | | | 350 | 250 | | 48 | | 1800 | 2260 | | | | | | | | | | | | | | |
| 20BF | 324T/326T | | | 40, 50 | 40, 50 | 14.13 | 30 | 16.50 | 440 | 580 | 29.06 | 48 | 15.75 | 13.66 | 43.75 | 244 | 1" | | | | | | |
| | 324TS/325TS | 50, 60 | 40, 50 | | | | 29 | | 4810 | 520 | | | | | | | | | | | | | |
| | 364T/365T | | | 60, 75 | 60, 75 | 15.06 | 34 | 18.25 | 665 | 835 | | | | | | | | | | | | | |
| | 364TS/365TS | 75, 100 | 60, 75 | | | | 32 | | 730 | 820 | | | | | | | | | | | | | |
| | 404TS/405TS | 125, 150 | 100 | | | 18 | 36 | 20.13 | 950 | 1150 | | | | | | | | | | | | | |
| | 404T/405T | | | 100, 125 | 100 | | 39 | | 930 | 1160 | | | | | | | | 1" | | | | | |
| | 444TS/445TS | 200-300 | 125, 150 | | | 19.56 | 41 | 22.38 | 1250 | 1615 | | | | | | | | | | | | | |
| | 444T/445T | | | 150-300 | 125-200 | | 45 | | 1370 | 1650 | | | | | | | | | | | | | |
| | 447TS | 350 | 200 | | | 21.69 | 47 | | 1800 | 2550 | | 60.25 | | | 56 | 345 | | N/A | | | | | |
| | 449TS | 400-450 | 250-400 | | | | 51 | 23.75 | 1850 | 2550 | | | | | | | | | | | | | |
| 447T | | | 350 | 250 | | 48 | | 1800 | 2260 | | | | | | | | | | | | | | |

NOTE: 1. Dimensions in inches, weight in pounds.
 2. Not to be used for construction purposes.

NOTA: 1. Dimensiones en pulgadas, peso en libras.
 2. No utilizar con fines de construcción.

3756 M & L-Group SAE Drive Dimensions and Weights

Dimensiones y pesos del mando SAE Grupo L y 3756 M

Packed Box

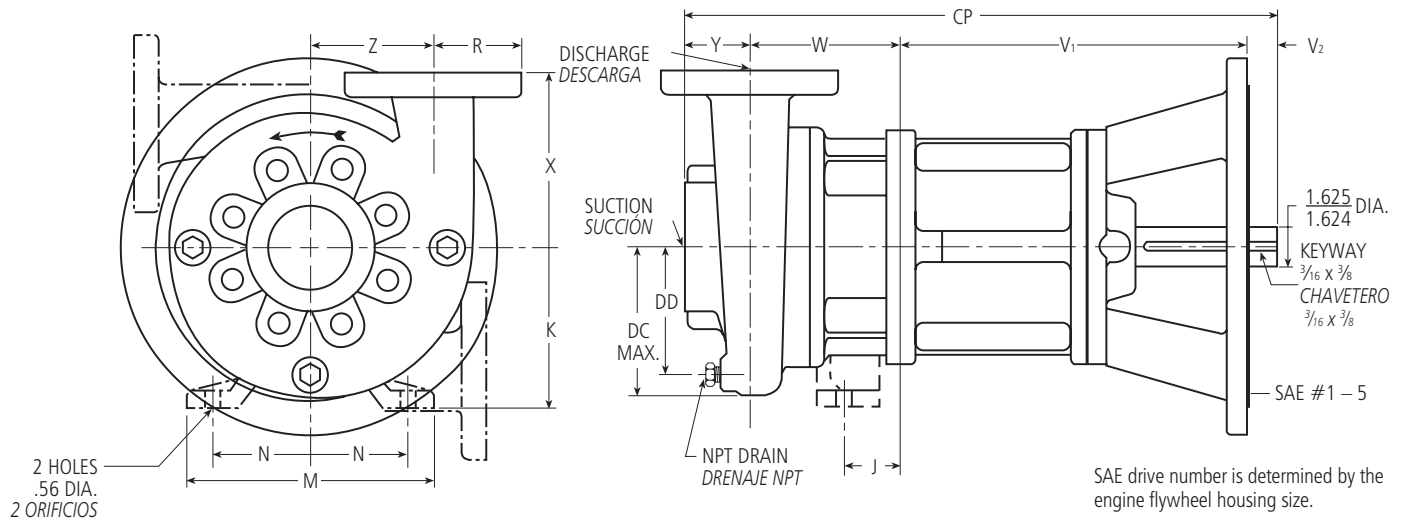

Dimensions and Weights

Pesos y dimensiones

| Pump Bomba | Suction Succión | Discharge Descarga | CP | DC (Max.) | DD | J | K | M | N | R | NPT Drain Drenaje NPT | W | X | Y | Z | Weight (lbs.) Pesos (libras) | | |
|---------------|-----------------|--------------------|----------------------------------|--------------------------------|-------------------------------|---------------------------------|-------------------------------|----|----|---------------------------------|-------------------------------|--------------------------------|----|-------------------------------|-------------------------------|-------------------------------|-----|-----|
| 1½ x 2 – 10 | 2* | 1½* | 25 ⁷ / ₁₆ | 6 ³ / ₄ | 5 ⁷ / ₈ | — | — | — | — | 1 ¹ / ₄ | ¼ | 7 ⁷ / ₈ | 6 | 3 | 5½ | 235 | | |
| 2½ x 3 – 8 | 3* | 2½* | 25 ¹⁵ / ₁₆ | 6 ¹ / ₄ | 5 ¹ / ₄ | — | — | — | — | 1 ¹³ / ₁₆ | | 8 | | 3 ³ / ₈ | 5 | 220 | | |
| 2½ x 3 – 9 | 3 | 2½ | 25 ³ / ₁₆ | 7 ¹ / ₈ | 6 | — | — | — | — | 3½ | ⅜ | 7 ⁷ / ₈ | 7½ | 2¾ | 5½ | 230 | | |
| 2½ x 3 – 10 | | | 25 ⁵ / ₁₆ | 8 ⁷ / ₈ | 7 ⁵ / ₈ | — | — | — | — | — | | | | — | 9 | 3 | 7½ | 285 |
| 2½ x 3 – 13 | 4 | 3 | 22 ³ / ₄ | 6 ¹ / ₄ | 5 ³ / ₈ | — | — | — | — | — | ¼ | 8 ³ / ₁₆ | 7 | 3 | 5 ⁵ / ₈ | 225 | | |
| 3 x 4 – 8 | | | 25 ⁹ / ₁₆ | 7 ³ / ₈ | 6 ¹ / ₂ | — | — | — | — | — | | 8 | | | 7½ | 5½ | 240 | |
| 3 x 4 – 10 | | | 25 ¹⁵ / ₁₆ | 9 ¹ / ₂ | 8 ¹ / ₈ | — | — | — | — | — | | 7 ⁷ / ₈ | | | 9 | 7½ | 300 | |
| 3 x 4 – 13 | 5 | 4 | 25 ³ / ₁₆ | 6 ¹ / ₈ | 5 ³ / ₄ | — | — | — | — | — | ⅜ | 8 ³ / ₈ | 8 | 5 | 240 | | | |
| 4 x 5 – 8 | | | 27 ¹ / ₁₆ | 8 ³ / ₈ | 7½ | — | — | — | — | — | | 8 ³ / ₈ | | | 8½ | 3 ³ / ₈ | 7 | 280 |
| 4 x 6 – 10 | 6 | 4 | 25 ¹¹ / ₁₆ | 9 ³ / ₄ | 8 ¹ / ₈ | — | — | — | — | — | 4½ | 8 ¹ / ₈ | 9 | 3 | 7½ | 315 | | |
| 4 x 6 – 13 | | | 27 ³ / ₁₆ | 12 ³ / ₄ | 11 | 1 ¹⁵ / ₁₆ | 9 ³ / ₄ | 16 | 7 | — | | 8 ⁵ / ₈ | | | 12 | 4 | 10½ | 500 |
| ■ 4 X 6 – 16 | | | 8 ³ / ₈ | 11 | 3 | 8 ³ / ₄ | 400 | | | | | | | | | | | |
| ■ 6 X 8 – 13 | 8 | 6 | 25 ¹⁵ / ₁₆ | 12 ³ / ₄ | 10½ | 2 ³ / ₈ | 7½ | 13 | 5½ | 5½ | 8 ³ / ₈ | 11 | 3 | 8¾ | 400 | | | |
| ■ 8 x 10 – 13 | 10 | 8 | 27 ³ / ₁₆ | 14 ³ / ₄ | 13 | 2 ³ / ₈ | 7½ | 13 | 5½ | 6¾ | 8 ³ / ₈ | 12¾ | 4 | 10 | 585 | | | |

*Denotes NPT connection. All other connections are for use with ANSI class 150 mating flanges.
 Dimensions in inches, weights in lbs. Do not use for construction purposes.
 * Indica conexión NPT Las demás conexiones deben usarse con bridas de contacto ANSI clase 150.
 Dimensiones en pulgadas, peso en libras. No utilizar para fines de construcción.
 ■ Indicates "L" Group pump., ■ Indica una bomba Grupo "L".

| SAE # | V ₁ | V ₂ |
|---------|----------------|----------------|
| 1, 3, 5 | 13¾ | 1½ |
| 2, 4 | 13 | 1¾ |

NOTE:

- All pumps shipped in horizontal discharge position. For other orientations, remove casing bolts, rotate to desired position, and tighten ¾ - 16 casing bolts to 37 ft./lbs. torque., ½ - 13 casing bolts to 90 ft./lbs. torque.
- Dimensions in inches, weight in pounds.
- Not to be used for construction purposes.

NOTA:

- Todas las bombas se embarcan con la descarga en posición horizontal. Para otras orientaciones, retire los pernos de la carcasa, haga rotar la descarga hasta la posición deseada y ajuste los 16 pernos de ¾ de pulgada a una torsión de 37 pies/libra, y los 13 pernos de ½ pulgada a 90 pies/libra.
- Dimensiones en pulgadas, peso en libras.
- No utilizar con fines de construcción.

3756 M & L-Group SAE Drive Dimensions and Weights

Dimensiones y pesos del mando SAE Grupo L y 3756 M

Mechanical Seal

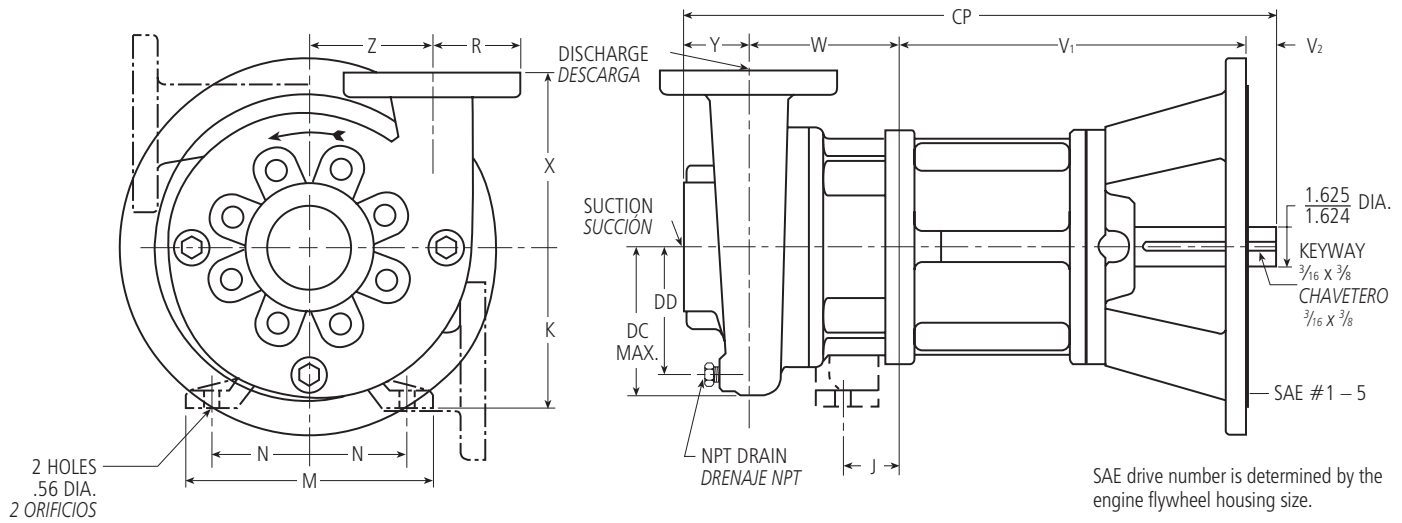

SAE drive number is determined by the engine flywheel housing size.
El número del mando SAE se determina por el tamaño de la caja del volante del motor.

Dimensions and Weights

Pesos y dimensiones

| Pump Bomba | Suction Succión | Discharge Descarga | CP | DC (Max.) | DD | J | K | M | N | R | NPT Drain Drenaje NPT | W | X | Y | Z | Weight (lbs.) Pesos (libras) | | | |
|----------------|-----------------|--------------------|----------|-----------|--------|-------|-------|----|-------|---------|-----------------------|--------|-------|-------|-------|------------------------------|-------|--------|-------|
| 1 1/2 x 2 - 10 | 2* | 1 1/2* | 22 3/16 | 6 3/4 | 5 7/8 | — | — | — | — | 1 1/4 | 1/4 | 5 | 6 | 3 | 5 1/2 | 235 | | | |
| 2 1/2 x 3 - 8 | 3* | 2 1/2* | 23 1/16 | 6 1/4 | 5 1/4 | — | — | — | — | 1 13/16 | | 5 7/8 | | | | | 3 3/8 | 5 | 220 |
| 2 1/2 x 3 - 9 | 3 | 2 1/2 | 22 3/16 | 7 1/8 | 6 | — | — | — | — | 3 1/2 | 3/8 | 5 | 7 1/2 | 2 3/4 | 5 1/2 | 230 | | | |
| 2 1/2 x 3 - 10 | | | 22 7/16 | 8 7/8 | 7 5/8 | — | — | — | — | — | | | | | | | — | 9 | 3 |
| 2 1/2 x 3 - 13 | 4 | 3 | 19 7/8 | 6 1/4 | 5 5/8 | — | — | — | — | — | 1/4 | 5 5/16 | 7 | 3 | 5 5/8 | 225 | | | |
| 3 x 4 - 8 | | | 22 11/16 | 7 3/8 | 6 1/2 | — | — | — | — | 3 3/4 | | 5 5/8 | | | | | 7 1/2 | 5 1/2 | 240 |
| 3 x 4 - 10 | | | 22 9/16 | 9 1/2 | 8 1/8 | — | — | — | — | — | | — | | | | | 5 | 9 | 7 1/2 |
| 3 x 4 - 13 | 5 | 4 | 22 13/16 | 6 1/8 | 5 3/4 | — | — | — | — | — | 3/8 | 5 1/2 | 8 | 3 | 5 | 240 | | | |
| 4 x 5 - 8 | | | 24 5/16 | 8 5/8 | 7 1/2 | — | — | — | — | 4 1/2 | | 5 1/2 | | | | | 8 1/2 | 3 3/8 | 7 |
| 4 x 6 - 10 | 6 | 4 | 22 13/16 | 9 3/4 | 8 1/8 | — | — | — | — | — | 3/8 | 5 1/4 | 9 | 3 | 7 1/2 | 315 | | | |
| 4 x 6 - 13 | | | 27 3/16 | 12 3/4 | 11 | 1 7/8 | 9 3/4 | 16 | 7 | 8 5/8 | | 12 | | | | | 4 | 10 1/2 | 500 |
| ■ 4 x 6 - 16 | 8 | 6 | 25 13/16 | 12 3/4 | 10 1/2 | 2 3/8 | 7 1/2 | 13 | 5 1/2 | 5 1/2 | 3/8 | 8 3/8 | 11 | 3 | 8 3/4 | 400 | | | |
| ■ 6 x 8 - 13 | | | 8 3/8 | 11 | 3 | 8 3/4 | 400 | | | | | | | | | | | | |
| ■ 8 x 10 - 13 | 10 | 8 | 27 3/16 | 14 3/4 | 13 | 2 3/8 | 7 1/2 | 13 | 5 1/2 | 6 3/4 | 8 3/8 | 12 3/4 | 4 | 10 | 585 | | | | |

*Denotes NPT connection. All other connections are for use with ANSI class 150 mating flanges.
Dimensions in inches, weights in lbs. Do not use for construction purposes.
* Indica conexión NPT Las demás conexiones deben usarse con bridas de contacto ANSI clase 150.
Dimensiones en pulgadas, peso en libras. No utilizar para fines de construcción.
■ Indicates "L" Group pump., ■ Indica una bomba Grupo "L".

| SAE # | V1 | V2 |
|---------|--------|-------|
| 1, 3, 5 | 13 1/4 | 1 1/2 |
| 2, 4 | 13 | 1 3/4 |

NOTE:

- All pumps shipped in horizontal discharge position. For other orientations, remove casing bolts, rotate to desired position, and tighten 3/8 - 16 casing bolts to 37 ft./lbs. torque., 1/2 - 13 casing bolts to 90 ft./lbs. torque.
- Dimensions in inches, weight in pounds.
- Not to be used for construction purposes.

NOTA:

- Todas las bombas se embarcan con la descarga en posición horizontal. Para otras orientaciones, retire los pernos de la carcasa, haga rotar la descarga hasta la posición deseada y ajuste los 16 pernos de 3/8 de pulgada a una torsión de 37 pies/libra, y los 13 pernos de 1/2 pulgada a 90 pies/libra.
- Dimensiones en pulgadas, peso en libras.
- No utilizar con fines de construcción.

Specifications

Especificaciones

Capacities to:

1600 GPM (363 m³/hr) at
3500 RPM
4500 GPM (1020 m³/hr) at
1750 RPM

Heads to:

490 feet TDH (150 m) at 3500 RPM
300 feet TDH (90 m) at 1750 RPM

Working pressure to:

200 PSIG (14 bars)

Suction pressure to:

100 PSIG (7 bars)

Maximum temperature to:

212°F (100°C) with standard seal or
250°F (121°C) with optional seal.

Motor:

NEMA standard JM frame for 3656
or T-frame for 3756 mechanical
seal, JP or T-frame for packed box.
Open drip proof, totally enclosed
fan cooled and explosion proof
enclosures available. Single phase
(115/230 V), 2-5 HP and three
phase (208 – 230/460 V) 2 – 150
HP are available at 1750 or 3500
RPM.

Direction of Rotation:

Clockwise viewed from motor end.

Capacidad hasta:

1600 GPM (363 m³/hr) a 3500 RPM
4500 GPM (1020 m³/hr) a 1750 RPM

Cargas hasta:

490 pies (150 m) carga dinámica total
a 3500 RPM
300 pies (90 m) carga dinámica total
a 1750 RPM

Presión de operación hasta:

200 PSIG (14 bars)

Presión de succión hasta:

100 PSIG (7 bars)

Temperatura máxima:

212 °F (100 °C) con sello estándar o
250 °F (121 °C) con sello optativo.

Motor:

NEMA JM estándar en el modelo
3656 y bastidor NEMA T estándar en
el modelo 3756 con sello mecánico,
bastidor JP o T para caja
prensaestopas. Las cubiertas
disponibles son: abierta a prueba de
filtración, totalmente encerrada con
enfriamiento por ventilador y a
prueba de explosiones. Motores
monofásicos (115/230 V), 2-5 HP y
trifásicos (208 – 230/460 V)
2 – 150 HP disponibles a
1750 ó 3500RPM.

Dirección de rotación:

Dextrorsa (sentido de las agujas del
reloj) cuando se mira desde el
extremo del motor.

Typical Applications

Aplicaciones típicas

- Booster service
 - Spraying systems
 - Irrigation
 - Water circulation
 - Liquid transfer
 - General purpose pumping
- Servicio de refuerzo
 - Sistemas de rociado
 - Sistemas de riego
 - Circulación de agua
 - Transferencia de líquidos
 - Aplicaciones de bombeo en general

Goulds Pumps is a brand of ITT Water Technology, Inc.
- a subsidiary of ITT Industries, Inc.

Goulds Pumps and the ITT Engineered Blocks Symbol are
registered trademarks and tradenames of ITT Industries.

www.goulds.com

*Goulds Pumps son una marca de fábrica de ITT Water
Technology, Inc. - un subsidiario de ITT Industries, Inc.*

*Goulds Pumps y el símbolo de bloques de tecnología ITT
son marcas y nombres registrados de ITT Industries.*

www.goulds.com