

3656SP

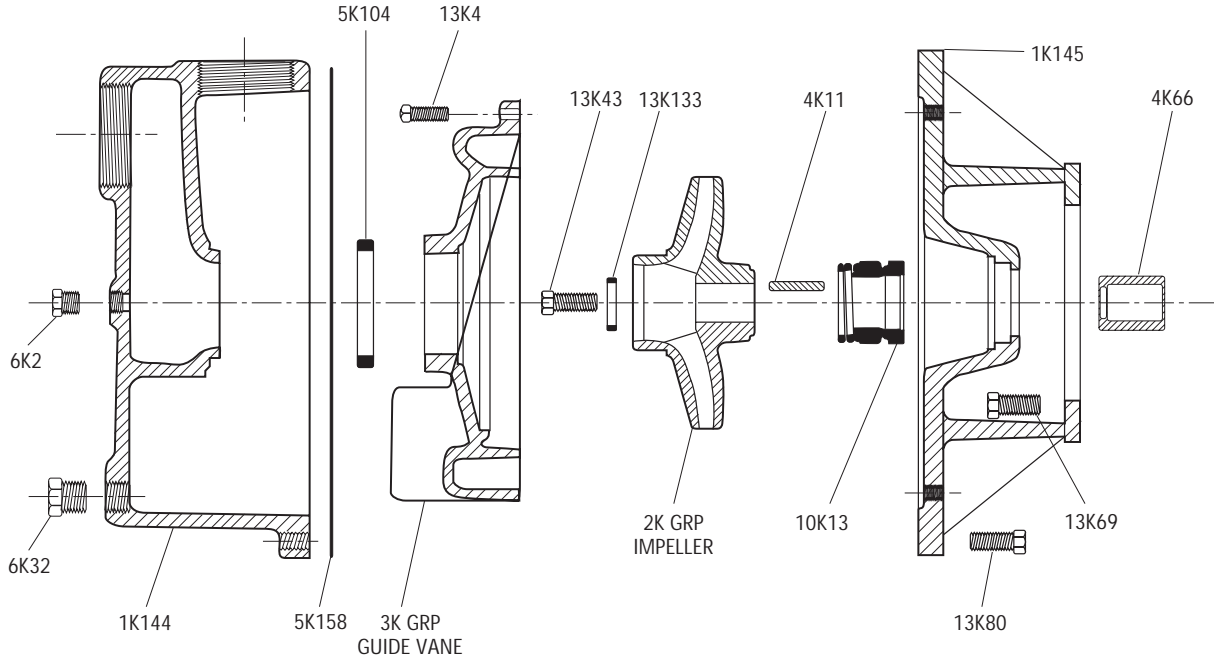

PART NO.	PART NAME	MATERIAL	PATTERN NO.
1K144	Casing 2 x 2 - 6	Cast Iron	59011
1K145	Adapter (140-180 FR)	Cast Iron	59077
2K119	Impeller 5 ¹⁵ / ₁₆ (5 HP)	Bronze	57185
2K123	Impeller 5 ¹ / ₈ (3 HP "M")	Bronze	57185
2K153	Impeller 5 ¹⁵ / ₁₆ (3 HP "H")	Bronze	57196
3K57	Guidevane (3 HP "H")	Bronze	59012
3K58	Guidevane (5 HP)	Bronze	57197
3K59	Guidevane (3 HP "M")	Bronze	57204
4K11	Impeller Key	18-8 SS	
4K66	Shaft Sleeve	18-8 SS	
4K282	Motor Spacer (140 FR)	Carbon Steel	NS*
4K283	Motor Spacer (180 FR)	Carbon Steel	NS*
5K104	Guidevane Seal Ring	BUNA	
5K158	Gasket-Casing	Composite	
6K2	Plug 1/4 NPT	Plated Steel	
6K32	Plug 3/4 NPT	Plated Steel	
10K13	Shaft Seal Assembly	Crane Type 21	
13K3	Hex Cap Screw	Plated Steel	NS**
13K4	Fillister Head Screw	303 SS	GV to Adapter
13K43	Impeller Bolt	18-8 SS	
13K69	Hex Cap Screw	Plated Steel	Adapter to Motor
13K71	Hex Cap Screw	Plated Steel	NS***
13K80	Hex Cap Screw	Plated Steel	Adapter to Casing
13K133	Impeller Washer	18-8 SS	
AL27121	Loctite #271		

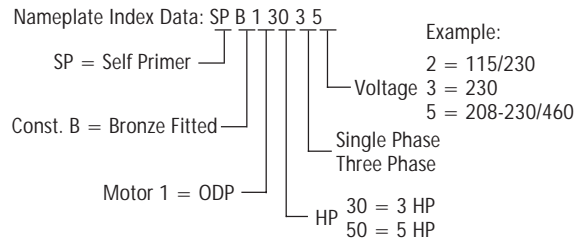

NOTES:
 Casings include plugs.
 Bond and seal shaft sleeve to shaft with Loctite #AL27121.
 Impellers on 3ø units are Loctited to motor shaft. Impeller and bolt must be heated to be removed. When replacing impeller, use Loctite AL27121. See instruction manual.
 Consult factory when ordering repair parts for pumps having a factory order number as the pump index number.
 * Not shown
 ** Not shown-motor to 140 FR spacer
 *** Not shown-motor to 180 FR spacer