



High-Pressure Vertically Immersed Multi-stage Booster Pump

MODEL

25VB

FEATURES

- **Multi-stage Design:** Provides steady, quiet, vibration free, operation.
- **O-ring Casing Seal:** Reliable high pressure sealing with easy disassembly for maintenance or repair.
- **Impellers and Diffusers:** Glass filled engineered composite material with floating impeller design. High resistance to corrosion and abrasion.
- **Bowls:** 300 stainless steel rabbit lock for positive alignment with no Gaskets required.
- **Variable Capacity:** Centrifugal pump design permits selection of flow within a range for each size.
- **Motors:** Close coupled NEMA 56J motors. Totally enclosed fan cooled. Three phase. Ball bearings carry all radial and axial thrust loads. Designed for continuous operation.
- **A tank mounting clamp** is provided for ease of adjustment to tank depth.
- **Optional stainless steel** suction and discharge.

SPECIFICATIONS

- Pump:**
- Capacities: to 33 GPM.
 - Heads: to 430 ft. (190 PSI).
 - Pipe Connections: 1" NPT.
 - Maximum flow: 33 GPM.
 - Minimum flow: 8 GPM.
 - Maximum Liquid Temperature: 160°F (71°C).

- Rotation:**
Counterclockwise when viewed from motor end.
- Maximum lift with foot valve: 10 ft. (check NPSH curve).

- Motor:**
- NEMA standard: 56J frame.
 - Totally enclosed fan cooled.
 - 60 Hz, 3500 RPM, three phase.
 - Three phase motors require starters, available separately.

APPLICATIONS

Mounts in a tank for circulation of cooling detergent solutions for machinery and parts cleaning.

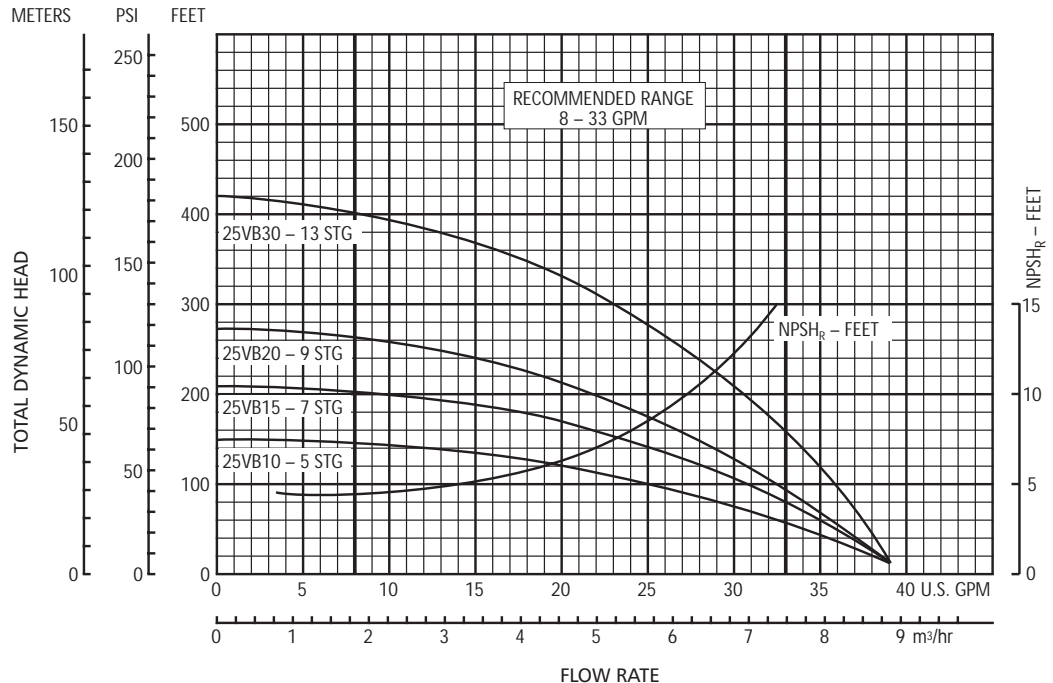

High-Pressure Vertically Immersed Multi-stage Booster Pump

MODEL

25VB

MATERIALS OF CONSTRUCTION

Item No.	Description	Material
1	Motor Adapter	Cast Iron or Cast 304 Stainless Steel
2	Mechanical Seal	2 = Carbon/Ceramic/BUNA 3 = Carbon/Silcar/EPR 4 = Carbon/Ceramic/Viton 5 = Carbon/Silcar/Viton
3	Shaft Coupling	Stainless Steel
4	Impeller/Diffuser	Engineered Composite
5	Bowl	304 Stainless Steel
6	Suction Head	Cast Iron or 304 Stainless Steel
7	Hex Shaft	Stainless Steel
8	Casing	304 Stainless Steel

DIMENSIONS AND WEIGHTS

Model	Stages	L1 Approx.	L2 Approx.	HP	L3 Max.	Max. Wt. lbs.
25VB10	5	10.62	12.62	1	10.00	43
25VB15	7	12.50	14.50	1½	10.86	48
25VB20	9	14.38	16.38	2	11.00	56
25VB30	13	18.12	20.12	3	11.25	64

Warnings:

- Do not run pump dry.
- Do not run pump below minimum flow.
- Mount pump so that suction is at least two inches above the tank bottom.
- Liquid level must be at least 5" above suction before starting pump.
- Not for use in condensate, acid or highly caustic solutions. Contact your distributor for specific applications.

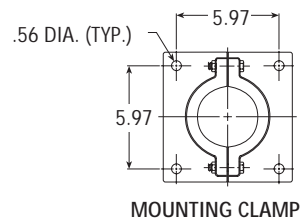
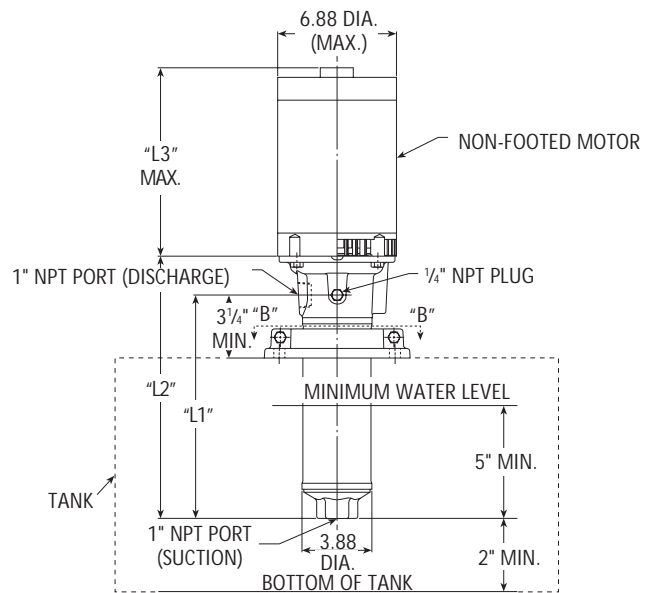
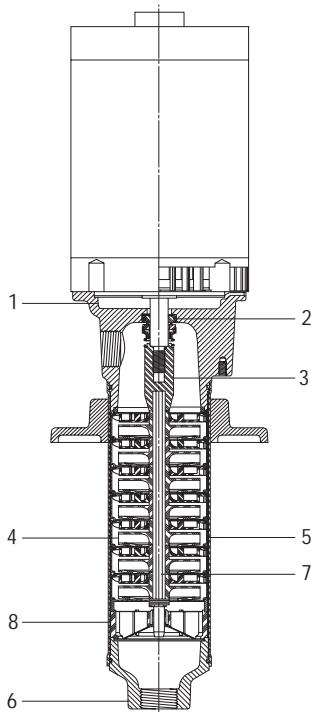

Goulds Pumps

