

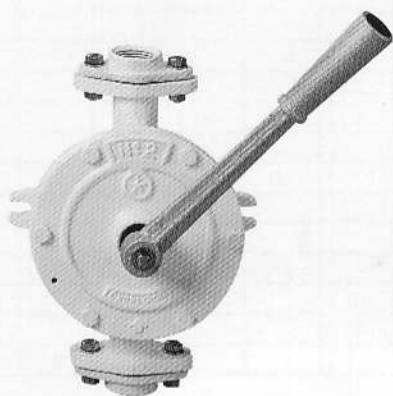

"EXCELSIOR-SUPER LARIO-JOLLY-MARE-PATAY"

POMPE A MANO
SERIE "EXCELSIOR-SUPER LARIO-JOLLY-
MARE-PATAY"

HAND PUMPS
"EXCELSIOR-SUPER LARIO-JOLLY-
MARE-PATAY" SERIES



EXCELSIOR

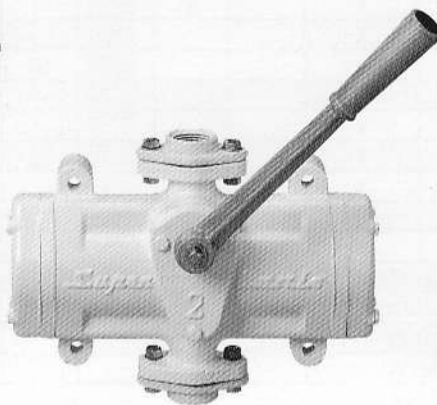

SUPER LARIO

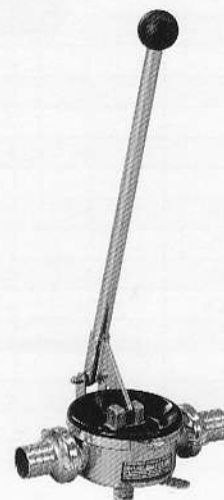

JOLLY JUNIOR

APPLICAZIONI:

Per il pompaggio di liquidi sia corrosivi che limpidi, per mare e dolce per svuotamento sentine, travaso gasolio, olio, ecc.

COSTRUZIONE:

GB: Corpo pompa in ghisa, parti interne in bronzo
B: Corpo pompa e parti interne in bronzo

GARANZIA:

Un anno (vedi condizioni generali di vendita)

GENERALITÀ:

EXCELSIOR: Pompa semirotaiva a doppio effetto aspirante-premente con una forte prevalenza.
SUPER-LARIO: Particolarmente indicata dove occorre aspirare da una notevole profondità anche in condizioni di impianto difficile (tubazioni non rettilinee) e con liquidi difficili da pompare. Pompa autoadescante con pistoni a doppio effetto; aspirazione fino a 8m.
JOLLY: Quando si richiede una pompa leggera, economica ma con una grande portata di liquido (a basse prevalenze) e si debba aspirare liquidi carichi di impurità.
MARE: Particolarmente indicata per usi nautici, come pompa di sentina e di emergenza, molto leggera, resistente, ispezionabile.
PATAY: Specifica per il travaso di acque, olii, fanghi, liquidi densi ecc. Questa pompa è leggera, ispezionabile, non intasabile.

APPLICATIONS:

To pump liquids, for fresh and sea water. Emptying bilge, tanks, intake diesel oil, oil etc.

CONSTRUCTION FEATURES:

GB: Body pump on cast iron, internal parts on bronze
B: Body pump and internal parts on bronze

WARRANTY:

One year (see our general sale conditions)

GENERALITY:

EXCELSIOR: Double acting semi-rotary hand wing pumps.
SUPER-LARIO: It is recommended for installations needing high suction lift. It is double acting pistons pump, self priming and the suction lift is up to 8 m.
JOLLY: When is request a light and cheap pump with a big delivery of water (with low head) and the liquids drained are dirty.
MARE: It is generally used as bilge or emergency pump; it is very light and strong.
PATAY: It is particularly used to intake water, oil, mud, dense liquids etc. This pump is light and hard to jam.



PRESTAZIONI

PERFORMANCES

MODELLO POMPA PUMP MODEL	GRANDEZZA SIZE	ESECUZIONI VERSIONS		PORTATA l/min					DELIVERY l/min					BOCCHE HEADS
				12	18	24	35	45	50	60	70	100		
				PORTATA m ³ /h					DELIVERY m ³ /h					
				0.72	1.08	1.4	2.1	2.7	3.0	3.6	4.2	6.0		
N°		GB	B	PREVALENZA TOTALE m H ₂ O					TOTAL MANOMETRIC HEAD mH ₂ O					
EXCELSIOR	0	X	X	30										1/2"
EXCELSIOR	1	X	X		30									3/4"
EXCELSIOR	2	X	X			30								1"
EXCELSIOR	3	X	X				30							1" 1/4
EXCELSIOR	4	X	X					30						1" 1/4
EXCELSIOR	5	X	x						30					1" 1/2
SUPER LARIO	2	X	X			30								1"
SUPER LARIO	3	X	X						30					1" 1/4
SUPER LARIO	4	X	X							30				1" 1/2
SUPER LARIO	5	X	X								30			2"
JOLLY JUNIOR M.	-	INOX/STEEL								4				40 mm.
T/A MARE	-	FIBERGLASS					15							38 mm.
PATAY SD 45	-	NILON					9							26 mm.
PATAY SD 120	-	NILON										6		40 mm.

DIMENSIONI E PESI

DIMENSION AND WEIGHT

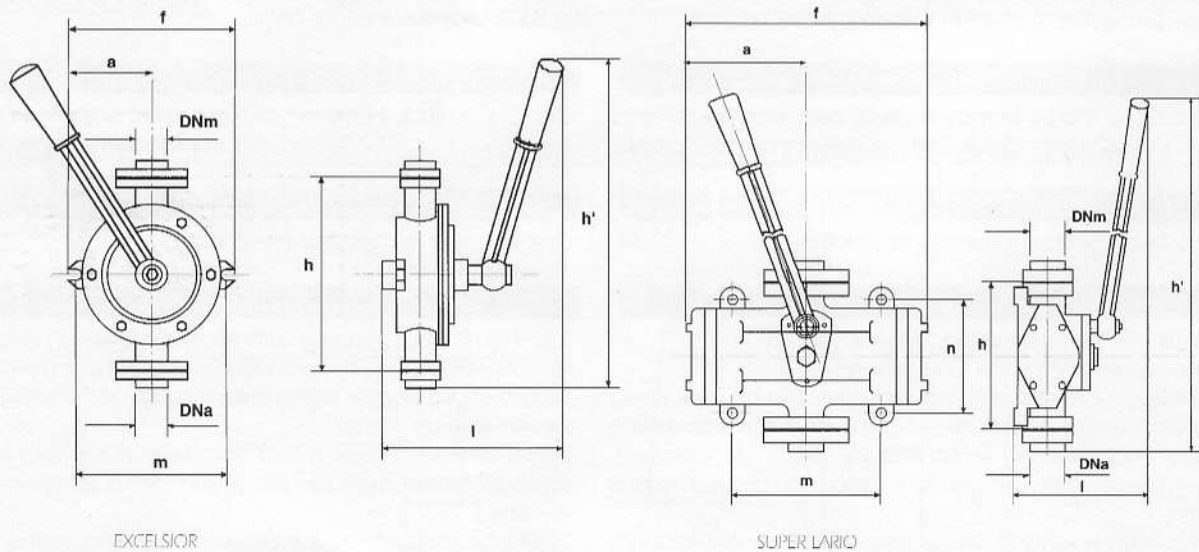

POMPA PUMP	f	h	h'	l	m	a	n	DNa	DNm	Kg
EXCELSIOR "0"	148	175	330	136	125	74	-	1/2"	1/2"	3.5
EXCELSIOR "1"	176	205	360	136	150	75	-	3/4"	3/4"	4.5
EXCELSIOR "2"	198	230	375	138	170	99	-	1"	1"	5.5
EXCELSIOR "3"	222	260	450	166	190	111	-	1" 1/4	1" 1/4	8.5
EXCELSIOR "4"	250	280	550	185	220	125	-	1" 1/4	1" 1/4	10.5
EXCELSIOR "5"	287	320	570	185	250	143	-	1" 1/2	1" 1/2	14
SUPER LARIO "2"	280	170	335	130	185	140	132	1"	1"	7.5
SUPER LARIO "3"	330	200	410	165	210	165	165	1" 1/4	1" 1/4	11
SUPER LARIO "4"	370	250	590	190	250	185	190	1" 1/2	1" 1/2	15
SUPER LARIO "5"	480	260	610	220	340	240	220	2"	2"	23