

"JET 4 B (C.C ÷ D.C.)"

EL/POMPA JET 4 B C.C

EL/PUMP JET 4 B D.C.



Gli esplosivi contenuti in questo catalogo sono indicati e possono essere modificati in qualsiasi momento senza preavviso. The exploded drawings in this catalogue are indicative and can be changed in every moment without notice.

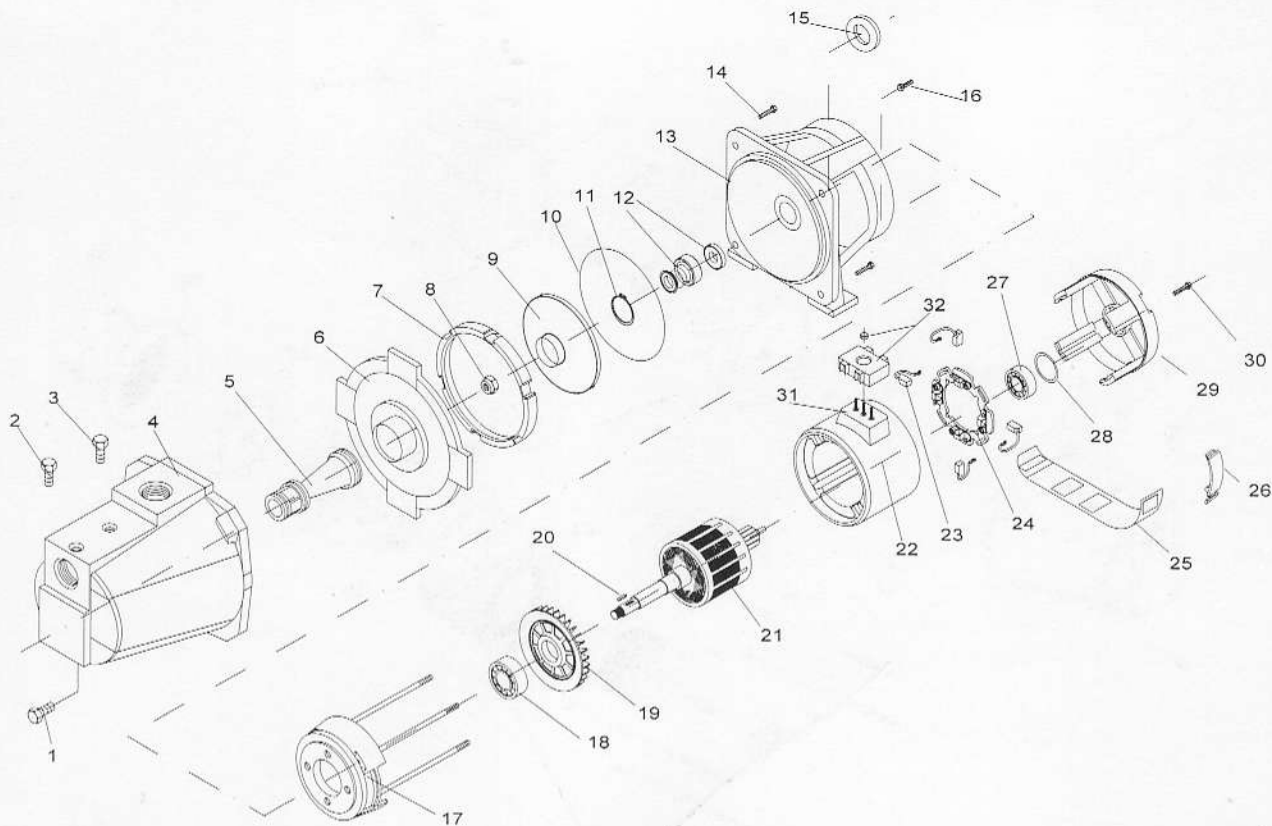

Vite scarico .1	1. Screw for discharge
Vite carico .2	2. Screw for charge
Vite carico .3	3. Screw for charge
Corpo pompa .4	4. Body pump
Venturi .5	5. Venturi
Disco porta-diffusore .6	6. Disk for diffuser
Dado di serraggio girante .7	7. Nut for impeller block
Diffusore .8	8. Diffuser
Girante .9	9. Impeller
O-ring .10	10. O-ring
Seeger .11	11. Seeger
Tenuta meccanica .12	12. Mechanical seal
Raccordo pompa motore .13	13. Motor pump fitting
Vite di fissaggio pompa .14	14. Screw for fixing pump
Anello paraspruzzi .15	15. Splash guard ring
Vite di fissaggio motore .16	16. Screw for fixing motor
Calotta anteriore .17	17. Front motor cover
Cuscinetto anteriore .18	18. Front bearing
Ventola di raffreddamento .19	19. Cooling fan
Chiavetta girante .20	20. Impeller key
Albero con pacco rotorico .21	21. Shaft with parcel rotor
Cassa motore .22	22. Motor case
Spazzole .23	23. Brushes
Anello porta spazzole .24	24. Brushes holder ring
Fascetta copri spazzole .25	25. Protection strip for brushes
Clip .26	26. Clip
Cuscinetto posteriore .27	27. Back bearing
Anello di compensazione .28	28. Compensation ring
Calotta posteriore .29	29. Back cover
Vite di sbloccaggio asse .30	30. Screw for shaft unblock
Morsettiera .31	31. Terminal box
Tappo copri morsettiera .32	32. Terminal box cover

DESCRIZIONE	COD.	DESCRIPTION
JET 4 B V.24 C.C.	01J4B1E	JET 4 B V.24 D.C.
JET 4R B V.24 C.C.	01J4B1RE	JET 4R B V.24 D.C.