

"FQ (C.A.÷A.C.)"

EL/POMPA FO C.A.

EL/PUMP FO A.C.



Gli esplosi contenuti in questo catalogo sono indicativi e possono essere modificati in qualsiasi momento senza preavviso.
 The exploded drawings in this catalogue are indicative and can be changed in every moment without notice.

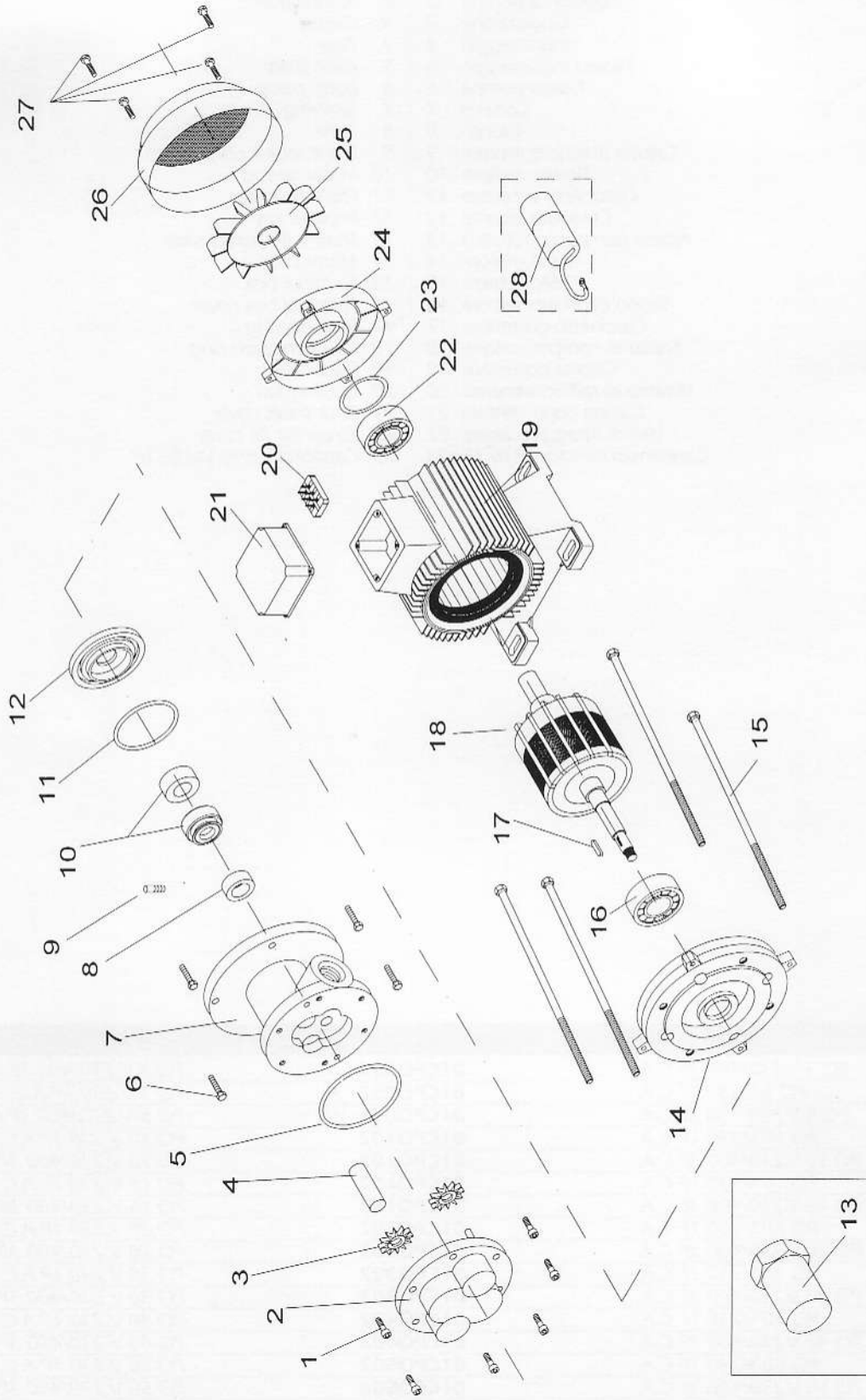

" F Q (C . A . ÷ A . C .) "

EL/POMPA FQ C.A.

EL/PUMP FQ A.C.



Vite fissaggio coperchio .1	1. Screw for fix cover
Coperchio pompa .2	2. Pump cover
Ingranaggio .3	3. Gear
Albero ingranaggio .4	4. Gear shaft
O-ring coperchio pompa .5	5. O-ring body pump cover
Vite .6	6. Screw
Corpo pompa .7	7. Body pump
Anello bloccaggio Tenuta meccanica .8	8. Mechanical seal's sliding ring
Grano .9	9. Grub screw
Tenuta meccanica .10	10. Mechanical seal
O-ring supporto Tenuta meccanica .11	11. Mechanical seal's O-ring support
Disco di supporto Tenuta meccanica .12	12. Mechanical seal disc support
By-pass .13	13. By-pass
Calotta anteriore motore .14	14. Front motor cover
Tirante motore .15	15. Motor tie rod
Cuscinetto anteriore .16	16. Front bearing
Chiavetta girante .17	17. Impeller key
Albero con pacco rotorico .18	18. Shaft with parcel rotor
Cassa motore .19	19. Motor case
Morsettiera .20	20. Terminal box
Tappo copri morsettiera .21	21. Terminal box cover
Cuscinetto posteriore .22	22. Back bearing
Anello di compensazione .23	23. Compensation ring
Calotta posteriore .24	24. Back cover
Ventola di raffreddamento .25	25. Cooling fan
Calotta copri ventola .26	26. Back sheet cover
Vite di fissaggio calotta .27	27. Screw for fix cover
Condensatore-solo V.230 1F .28	28. Capacitor - only V.230 1P

DESCRIZIONE	COD.	DESCRIPTION
FQ 5 V.230 1F C.A.	01CFQ052	FQ 5 V.230 1P A.C.
FQ 5 V.230/400 3F C.A.	01CFQ053	FQ 5 V.230/400 3P A.C.
FQ 10 V.230 1F C.A.	01CFQ102	FQ 10 V.230 1P A.C.
FQ 10 V.230/400 3F C.A.	01CFQ103	FQ 10 V.230/400 3P A.C.
FQ 15 V.230 1F C.A.	01CFQ152	FQ 15 V.230 1P A.C.
FQ 15 V.230/400 3F C.A.	01CFQ153	FQ 15 V.230/400 3P A.C.
FQ 25 V.230 1F C.A.	01CFQ252	FQ 25 V.230 1P A.C.
FQ 25 V.230/400 3F C.A.	01CFQ253	FQ 25 V.230/400 3P A.C.
FQ 40 V.230 1F C.A.	01CFQ402	FQ 40 V.230 1P A.C.
FQ 40 V.230/400 3F C.A.	01CFQ403	FQ 40 V.230/400 3P A.C.
FQ 50 V.230 1F C.A.	01CFQ502	FQ 50 V.230 1P A.C.
FQ 50 V.230/400 3F C.A.	01CFQ503	FQ 50 V.230/400 3P A.C.
FQ 70 V.230 1F C.A.	01CFQ702	FQ 70 V.230 1P A.C.
FQ 70 V.230/400 3F C.A.	01CFQ703	FQ 70 V.230/400 3P A.C.