

"CP 40 (C.C.÷D.C.)"

EL/POMPA CP 40 C.C.

EL/PUMP CP 40 D.C.

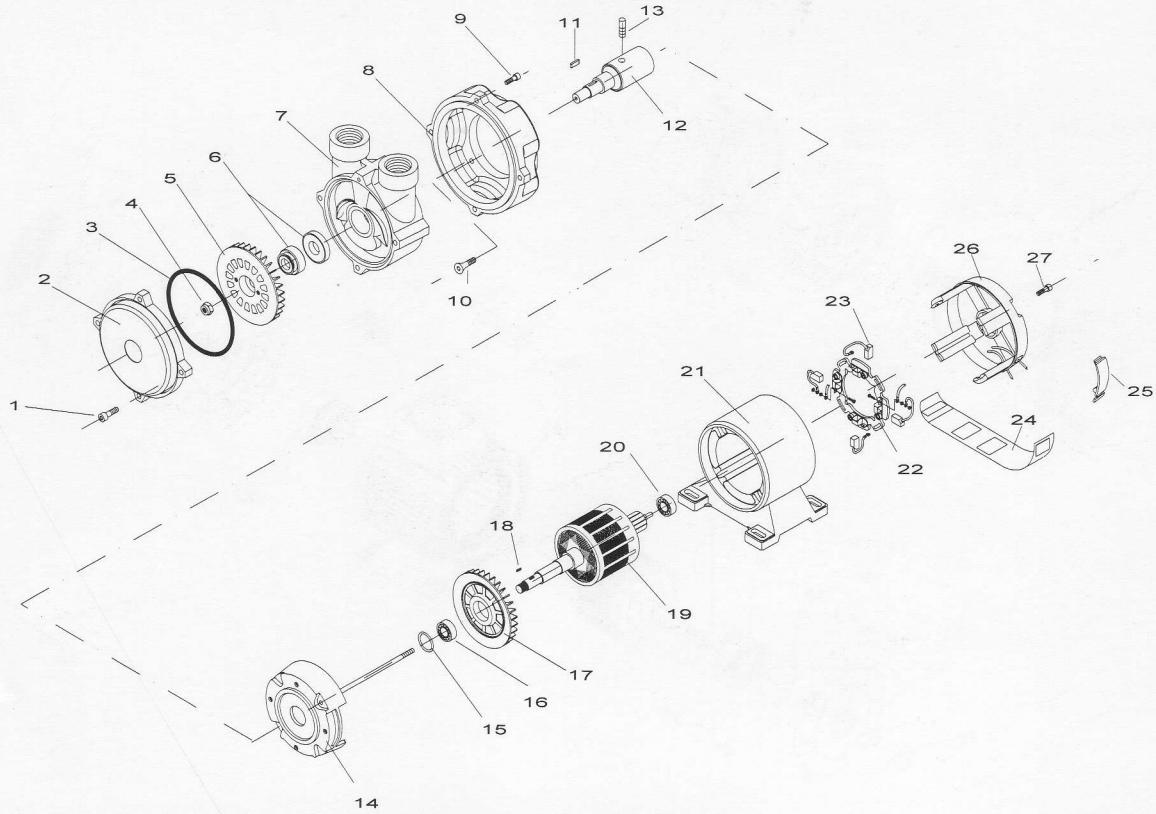

Gli esplosi contenuti in questo catalogo sono indicativi e possono essere modificati in qualsiasi momento senza preavviso.
 The exploded drawing in this catalogue are indicative and can be changed in every moment without notice.

Vite fissaggio coperchio	.1	1. Screw for fix cover
Coperchio pompa	.2	2. Pump cover
O-ring	.3	3. O-ring
Dado bloccaggio girante	.4	4. Impeller block nut
Girante	.5	5. Impeller
Tenuta meccanica	.6	6. Mechanical seal
Corpo pompa	.7	7. Body pump
Raccordo pompa motore	.8	8. Motor pump fitting
Vite	.9	9. Screw
Vite	.10	10. Screw
Chiavetta girante	.11	11. Impeller key
Albero adattatore	.12	12. Adapter shaft
Grano	.13	13. Grub screw
Calotta anteriore motore	.14	14. Front motor cover
Anello di compensazione	.15	15. Compensation ring
Cuscinetto anteriore	.16	16. Front bearing
Ventola di raffreddamento	.17	17. Cooling fan
Chiavetta albero adattatore	.18	18. Adapter shaft key
Albero con pacco rotorico	.19	19. Shaft with parcel rotor
Cuscinetto posteriore	.20	20. Back bearing
Cassa motore	.21	21. Motor case
Anello porta spazzole	.22	22. Brushes holder ring
Spazzole	.23	23. Brushes
Fascetta copri spazzole	.24	24. Protection strip for brushes
Clip	.25	25. Clip
Calotta posteriore motore	.26	26. Back motor cover
Vite di sbloccaggio asse	.27	27. Screw for shaft unblock

DESCRIZIONE

CP 40 N V.24 C.C.

COD.

01ACP401N

DESCRIPTION

CP 40 N V.24 D.C.