

Fluid-o-Tech "Quiet Cool" oscillating piston pumps

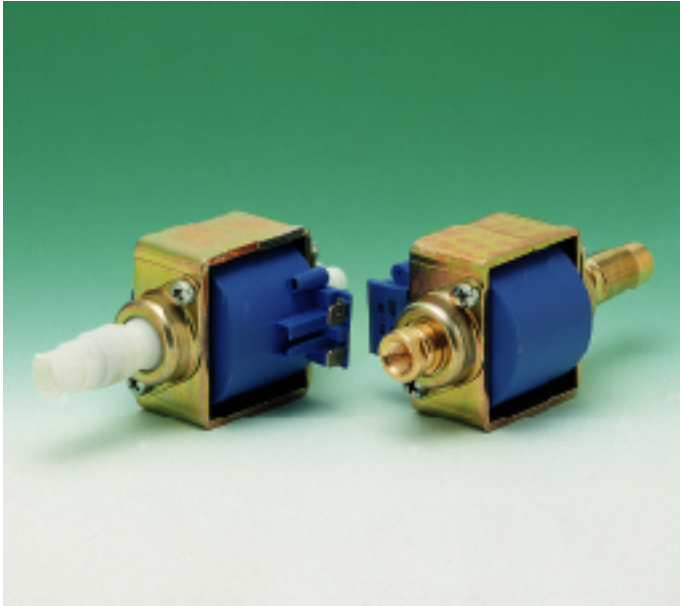

The "Quiet cool" oscillating piston pump is one of a range of new generation selfpriming compact pumps which embodies design excellence coupled with an impressive performance and availability.

Designed for pumping a range of liquids, including potable water, semiaggressive fluids and food quality low viscous syrups at relatively high pressures under continuous operation, the pump operates under the oscillating piston principle whereby motion occurs when the coil is energized with unidirectional impulses created by an alternating current passing through a diode.

Technical features and manufacturing characteristics

The technical features of the "Quiet Cool" pumps are a choice of brass or plastic flanges with 1/8" GAS threaded or barbed inlet ports and 1/8" GAS outlet ports; the check valves incorporate glass or EPDM balls; and a piston of stainless steel which oscillates within a brass or plastic guide tube.

The pumps may be installed in any position using the specially designed shock absorbing spring with cradles or the moulded rubber mounts.

Electrical characteristics:

Voltage : 230 V	Voltage : 120 V
Frequency : 50 Hz	Frequency : 60 Hz
Power : 35 W	Power : 40 W
Current : 0,23 A	Current : 0,51 A

Main applications:

- Liquid circulation
- Liquid spraying and injection
- Ultra filtration
- Espresso coffee machines
- Steam generators
- Carpet cleaners

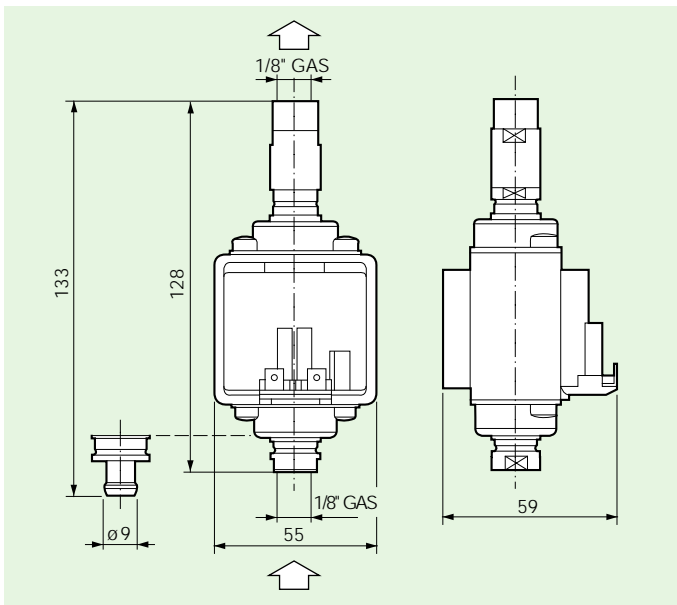

Wiring diagram

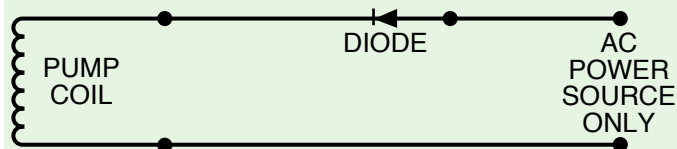

Diode wiring diagram to follow when the pump is supplied without plug



Fluid-o-Tech srl
20143 Milano - Via Morimondo, 23
Tel. (39) 02 8917071 - Fax (39) 02 8917079
<http://www.fluidotech.it>

Fluid-o-Tech International, Inc
161 Atwater St., Plantsville, CT 06479
Tel. (860) 276-9270 - Fax (860) 620-0193

Fluid-o-Tech "Quiet Cool" oscillating piston pumps

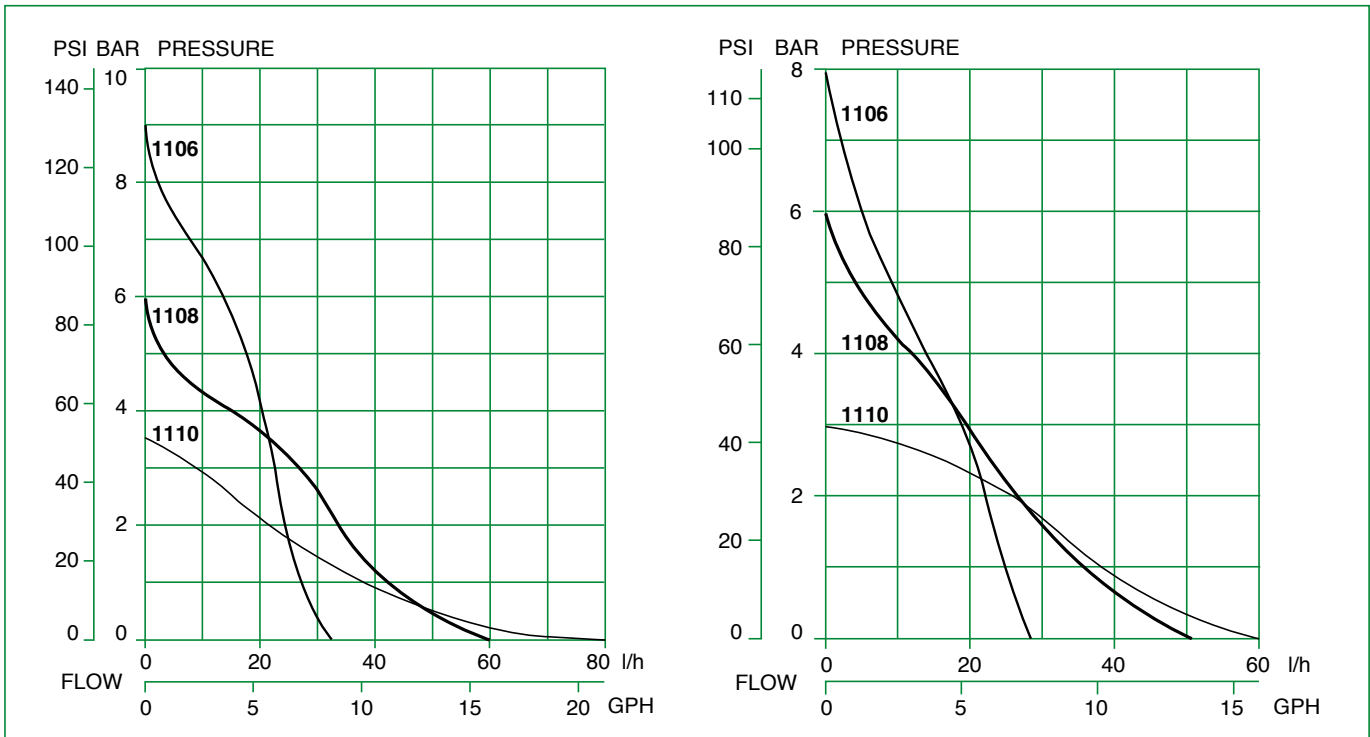
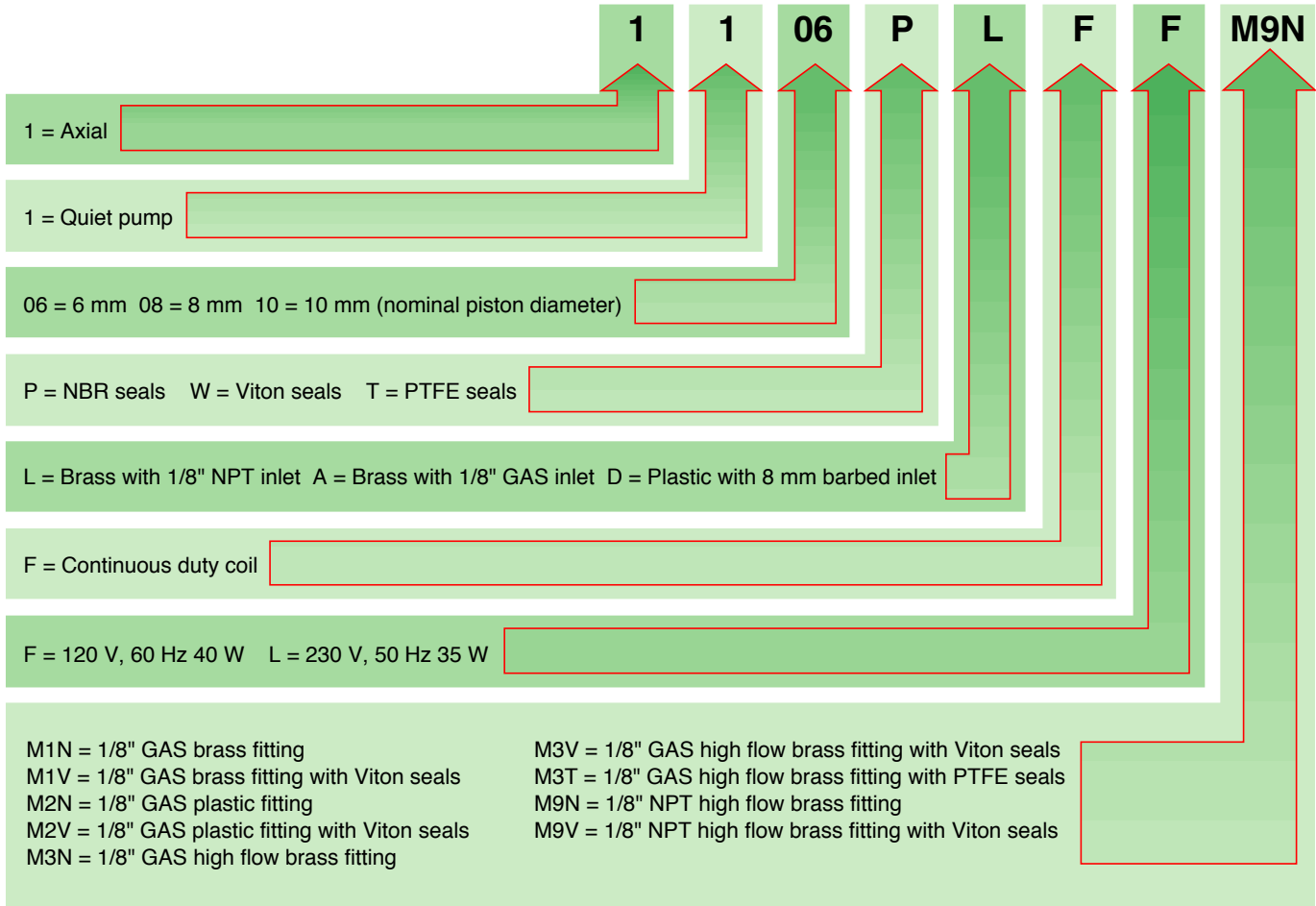

Fluid-o-Tech srl

20143 Milano - Via Morimondo, 23 - Tel. (39) 02 8917071 - Fax 02 89170799
<http://www.fluidotech.it>