

Fluid-o-Tech magnet drive gear pumps MG 200 series spare parts list and refurbishing instructions

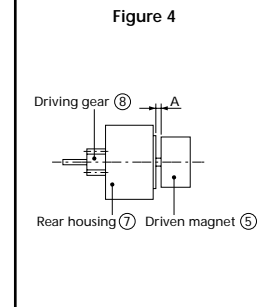
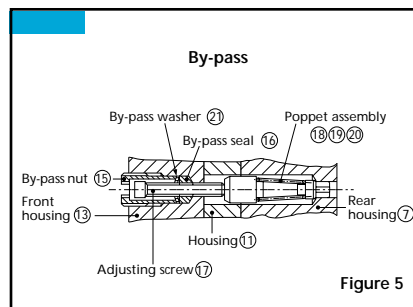
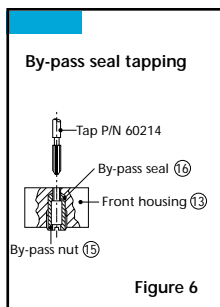
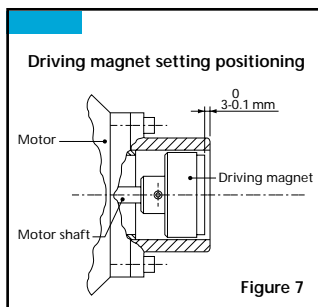
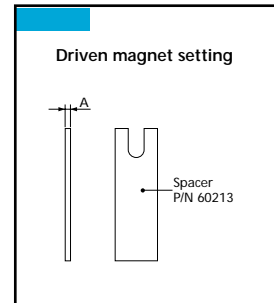
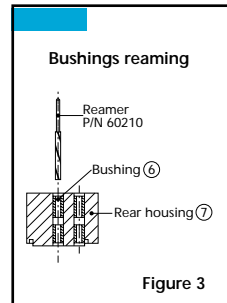
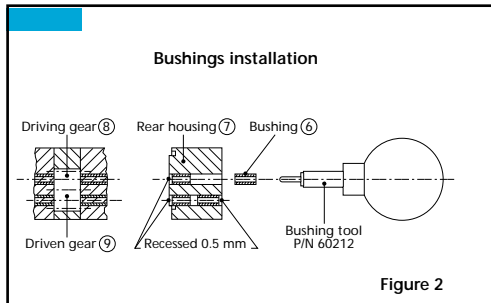
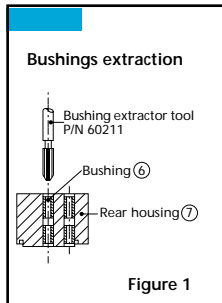
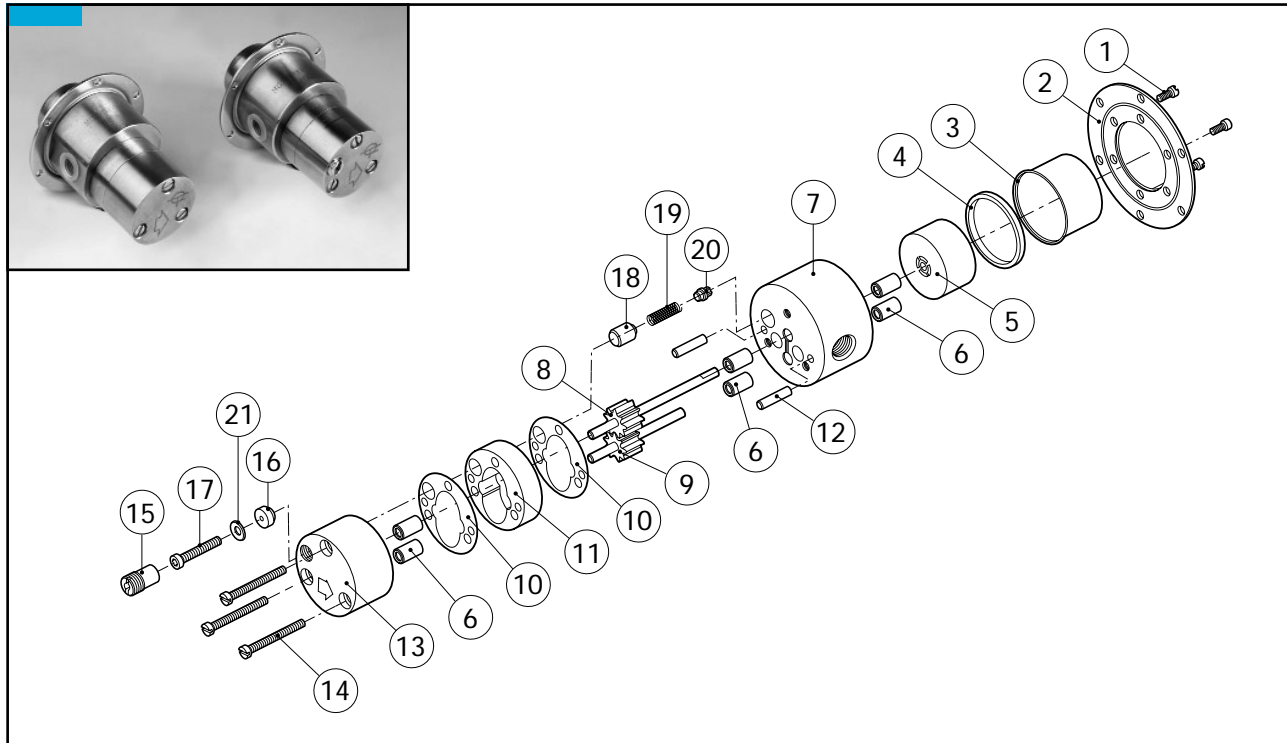

Fluid-o-Tech magnet drive gear pumps MG 200 series spare parts list and refurbishing instructions

Disassembly Instructions

Provide a clean surface for work area.

Separate the pumphead from the magnet cap.

Remove the 3 screws (14) and disassemble front housing (13), driven gear (9), central housing (11) and dowel pins (12).

If the pump is equipped with by-pass, make sure not to damage the sealing poppet (20).

Remove the poppet assembly from the adjusting screw (17) (fig. 5), remove the by-pass nut (15), the adjusting screw (17) turning counter-clockwise, the by-pass washer (21) and the by pass seal (16) from the cap.

Remove the screws (1) which secure the magnet cup (3) and the mounting plate (2) to the rear housing (7) and disassemble.

Remove and discard all the bushings (6) from the rear housing (7) and the front housing (13) with the bushing extractor tool P/N 60211 (fig.1).

Remove seal (4) and flat seals (10) from the rear housing and from the front housing and discard them.

If wear on front housing, rear housing or center housing is excessive, rebuilding the pump may not be advisable.

Re-Assembly Instructions

Clean carefully all parts before re-assembling.

Any foreign body material clinging to magnet must be removed.

Note

Bushings - Bushings on both sides of gears must be recessed 0.5 mm from the face of the rear housing (7) and front housing (13) (fig. 2)

Bushings Installation - Press 6 new bushings (6) into the rear housing (7) and front housing (13) as shown in figure 2 using P/N 60212 installation tool.

Once in place, the bushings need to be reamed with P/N 60210 reamer tool (fig. 3).

Seals - Apply a thin coat of silicone grease on the central housing (11) surfaces and place the flat seals (10) on each side of it insert the driving gear (8) into the rear housing (7) and then insert the shaft of the driving gear in the driven magnet using the spacer P/N 60213 (fig. 4).

Insert 2 dowel pins (12) in the body.

Slip carefully central housing (11) onto dowel pins against body face, verifying the proper, alignment of the screw holes.

Install the driven gear (9) (The side of gear assembly with longer shaft extension goes into the rear housing).

If pump is equipped with by-pass, install the by-pass

seal (16), then by-pass nut (15) and tighten to prevent by-pass seal rotation.

Then tap the by-pass seal with the P/N 60214 tool (fig. 6).

Disassemble the by-pass nut and install by-pass washer and turn clockwise the adjusting screw (17) before installing again the by-pass nut tightening.

Align the cap bushing holes with gear shafts, and dowel pins (12) with cap dowel pin holes and assemble.

Make sure that the poppet assy goes fully into poppet holes and seat (fig. 5).

Install 3 screws (14) in cap (13) and tighten alternately as tight as possible.

Turn driven magnet with fingers to check for any binding during the rotation: the magnet should turn freely.

Install magnet cup (3) and mounting plate (2) with 3 screws (1) and turn alternately until tight.

Assemble the driving magnet to the motor (see fig. 7) and the pumphead to the motor.

Service Kit - MG Gear Pump

Stainless steel pumphead

	Gear material	Service Kit P/N
204 pumphead	PTFE	MGKT3
	RYTON®	MGKR3
	PEEK™	MGKP3
209 pumphead	PTFE	MGKT4
	RYTON®	MGKR4
	PEEK™	MGKP4
213 pumphead	PTFE	MGKT5
	RYTON®	MGKR5
	PEEK™	MGKP5

Service kit contents

2 gears - 1 Teflon "O" ring - 2 Teflon flat seals - 6 bearings

Service kit tools

1 reamer	P/N 60210
1 extractor	P/N 60211
1 bushing tool	P/N 60212
1 spacer	P/N 60213
1 tap	P/N 60214

SPARES & INSTRUCTIONS – 10/01 Ed.



Fluid-o-Tech
<http://www.fluidotech.it>

Via Morimondo, 23
 20143 Milano - Italy
 Tel. (39) 02 8917071
 Fax (39) 02 8917079

161 Atwater St.,
 Plantsville CT (USA) 06479
 Tel. (1) (860) 276-9270
 Fax (1) (860) 620-0193

AF204, 8-10-17, Fukasawa,
 Setagaya, Tokyo 158-0081 Japan
 Tel. (81) (0) 3-3705-5440
 Fax (81) (0) 3-5707-7414