

OPERATION AND PARTS MANUAL

DRUM PUMPS AND MOTORS

HVDP SERIES



TABLE OF CONTENTS

Introduction	3
Warranty	3
Chemical Reaction Disclaimer	3
Return Policy	3
Safety Precautions	4
Maintenance Precautions	4
HVDP Terminology	5
HVDP Series Assembly, Maintenance and Assembly	6
HVDP Series Drive Assembly Removal and Installation	7
HVDP Series Rotor Removal, Inspection and Installation	7
HVDP Series Stator Removal, Inspection and Installation	8
HVDP Series Seal Removal, Inspection and Installation	8
HVDP-HR Series Parts Schematic	9
HVDP-LR Series Parts Schematic	10
M58H and M59H 800W Motors Parts Schematic	11

INTRODUCTION

Finish Thompson is a designer and manufacturer of drum pumps and mixers available worldwide through a qualified, experienced network of distributors and/or representatives. Drum pump selection is easy with FTI's complete line of interchangeable motors and tubes.

WARRANTY

Finish Thompson Inc (manufacturer) warrants this product to be free of defects in materials and workmanship for a period of 180 days from date of purchase by original purchaser. If a warranted defect, which is determined by manufacturer's inspection, occurs within this period, it will be repaired or replaced at the manufacturer's option, provided (1) the product is submitted with proof of purchase date and (2) transportation charges are prepaid to the manufacturer. Liability under this warranty is expressly limited to repairing or replacing the product or parts thereof and is in lieu of any other warranties, either expressed or implied. This warranty does apply only to normal wear of the product or components. This warranty does not apply to products or parts broken due to, in whole or in part, accident, overload, abuse, chemical attack, tampering, or alteration. The manufacturer accepts no responsibility for product damage or personal injuries sustained when the product is modified in any way. If this warranty does not apply, the purchaser shall bear all cost for labor, material and transportation.

Manufacturer shall not be liable for incidental or consequential damages including, but not limited to process down time, transportation costs, costs associated with replacement or substitution products, labor costs, product installation or removal costs, or loss of profit. In any and all events, manufacturer's liability shall not exceed the purchase price of the product and/or accessories.

CHEMICAL REACTION DISCLAIMER

The user must exercise primary responsibility in selecting the product's materials of construction, which are compatible with the fluid(s) that come(s) in contact with the product. The user may consult Finish Thompson Inc. (manufacturer) and/or a manufacturer's representative/distributor agent to seek a recommendation of the product's material of construction that offers the optimum available chemical compatibility.

However neither Manufacturer nor agent shall be liable for product damage or failure, injuries, or any other damage or loss arising out of a reaction, interaction or any chemical effect that occurs between the materials of the products construction and fluids that come into contact with the product's internals.

RETURN POLICY

Should you have any problems with this product, please contact the distributor in your area. The distributor will then determine if a return to the factory is necessary and will contact the factory for a return authorization number.

SAFETY PRECAUTIONS

ALWAYS read the installation instructions before operating the pump.

ALWAYS wear protective clothing, eye protection and follow standard safety procedures when handling corrosive or personally harmful materials.

ALWAYS use protective gloves to prevent contact with hot surfaces.

NEVER use an open, splashproof or TEFC motors when pumping or mixing flammable or combustible material.

ALWAYS place the pump intake in fluid before starting the pump.

ALWAYS make sure the discharge hose and pump are both secured and properly supported before starting the pump.

ALWAYS make sure the pump is properly grounded when pumping flammable or combustible materials. This requires a static protection kit.

ALWAYS use a discharge hose that is chemically compatible with the fluid being pumped and is rated at the discharge temperature and pressure of the pump installation.

MAINTENANCE PRECAUTIONS

ALWAYS check motor rotation on LR versions (air and induction motors) before installing the motor onto the pump.

ALWAYS store the pump and motor upright and away from corrosive liquids and vapors.

ALWAYS check compatibility and temperature range of the pump with the liquids being used.

ALWAYS flush the unit after each use if the liquid being pumped can crystallize or harden.

ALWAYS re-lubricate the pump internals after cleaning.

NEVER pump liquids containing solids that can damage internal pump parts (i.e. metal chips).

NEVER allow the pump to run dry.

NEVER operate the pump against a closed discharge. If the pump is operated against a closed discharge, a bypass (pressure relief valve) must be used.

HVDP TERMINOLOGY

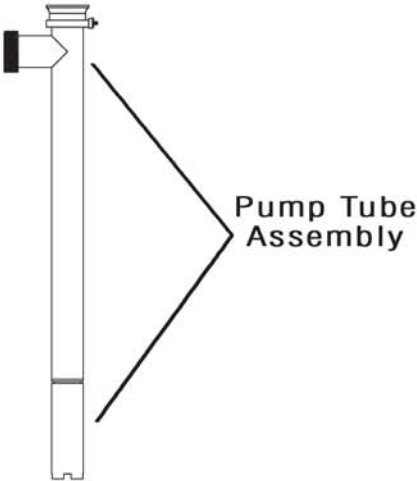
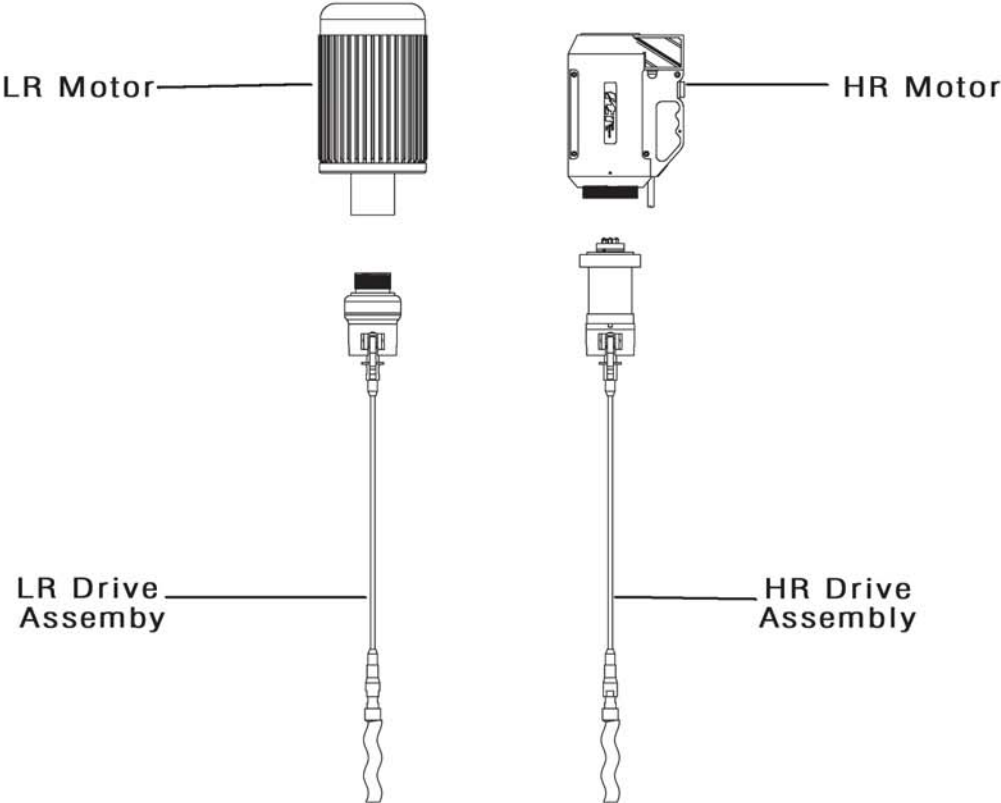

HVDP SERIES ASSEMBLY, MAINTENANCE & CLEANING INSTRUCTIONS

SECTION 1: MOTOR INSTALLATION AND REMOVAL

INSTALLATION - HVDP-HR

1. Locate the rubber coupling insert that was separately shipped in a plastic bag (see Figure 1).
2. Install the rubber coupling insert onto the metal coupling half located on top of the HR drive assembly.
3. Find the metal coupling half located inside the HR motor. Align this coupling with rubber insert installed in the second step of these instructions.
4. Slide the HR motor onto the HR drive assembly.
5. Hand tighten the motor nut onto the threaded nose of the HR motor.

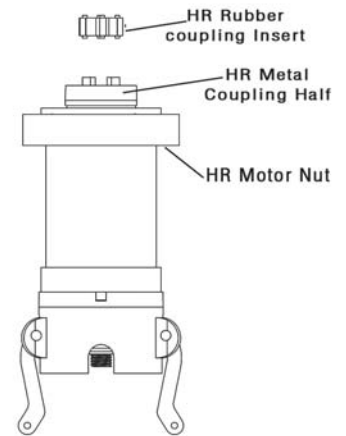

Figure 1

HVDP-HR REMOVAL: To remove the HR motor, reverse HR motor installation instructions found in this section.

INSTALLATION - HVDP-LR

1. Check the rotation direction of the LR motor.

⚠ WARNING: Motor rotation must be clockwise when viewed from the fan end of the motor. Rotating the motor in the wrong direction will cause damage to the pump.

2. Remove the motor adapter bolts (see Figure 2) and separate the motor adapter from the motor.
3. Thread the motor adapter onto the LR drive assembly. Hand tighten the motor adapter.
Note: Threads are left-handed. Also, thread lubricant is recommended to ensure smooth, bind free assembly.
4. The LR motor coupling consists of two 5/16" diameter pins welded to a hub. The LR drive assembly coupling has two slots that receive these pins. Align the pins of the motor coupling with the slots on the drive assembly coupling and slide the motor onto the drive assembly.

Note: Make sure the coupling is engaged properly and the motor adapter face is flush with the motor face.

5. Rotate the motor until the motor adapter mounting holes align with the threaded holes in the motor face.
6. Install the motor adapter bolts and torque to approximately 7 ft.-lbs. (9.5 N•M)

HVDP-LR REMOVAL:

1. Remove the LR motor adapter bolts.
2. Remove the LR motor.

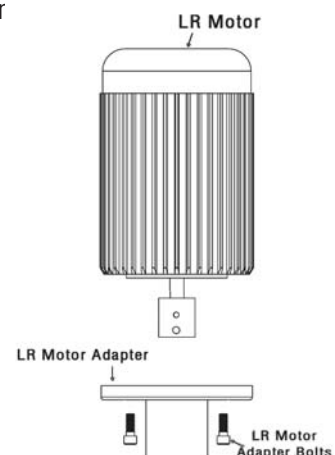

Figure 2

SECTION 2: DRIVE ASSEMBLY REMOVAL AND INSTALLATION

REMOVAL:

1. Remove the motor (see section 1 and follow the instructions for your model).
2. Remove the bail wire (see Figure 3).
3. Release the cam-lock by pulling the cam-lock levers towards the top of the drive assembly.
4. Pull the drive assembly out of the pump tube assembly while holding the cam-lock levers in the upright position.

INSTALLATION:

1. Make sure that the locating stud on the back of the pump tube assembly is aligned with the drive assembly coupling.
2. Push the drive assembly into the pump tube assembly while holding the cam lock levers in the upright position.
3. Rotate the cam-lock levers downward.
4. Install the bail wire.

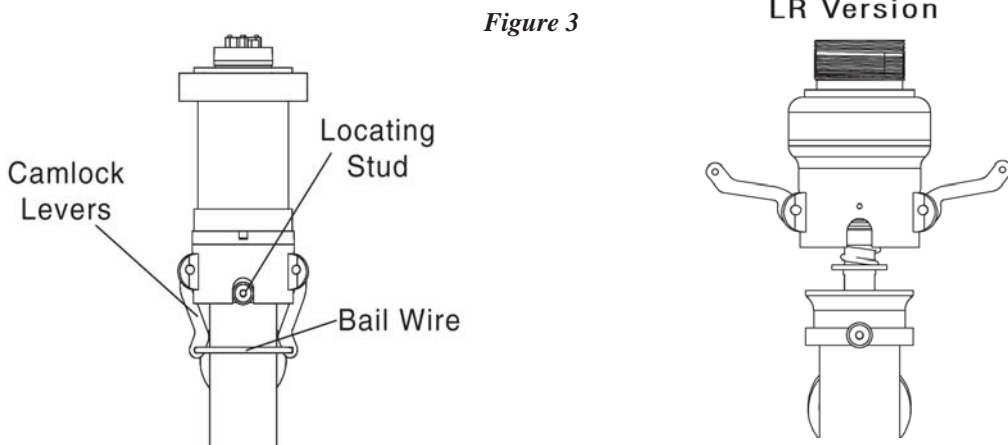

SECTION 3: ROTOR REMOVAL, INSPECTION, AND INSTALLATION

REMOVAL:

1. Remove the motor (see section 1 and follow the instructions for your model).
2. Remove the drive assembly (see section 2).
3. The rotor is located at the bottom of the drive assembly (see Figure 4).
4. Using 3/4" and 5/8" open-end wrenches, loosen and remove the rotor.

INSPECTION: Inspect the rotor for excessive wear and deep grooving.
Contact FTI if you are questioning the condition of the rotor.

INSTALLATION: Reverse the removal instructions found in this section.

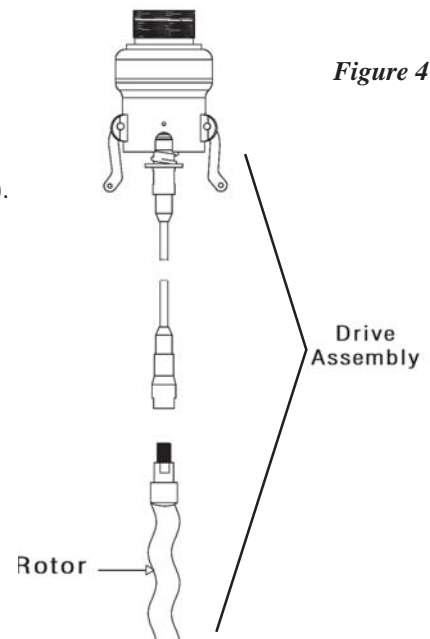

SECTION 4: STATOR REMOVAL, INSPECTION, AND INSTALLATION

REMOVAL:

1. Remove the motor (see section 1 and follow the instructions for your model).
2. Remove the drive assembly (see section 2).
3. The stator is located at the bottom of the pump tube assembly (see Figure 5).
4. Remove the stator by unthreading it from the pump tube. If the stator cannot be unthreaded by hand, insert a screwdriver into the slots found at the bottom of the stator. Use the screwdriver to rotate the stator.

Note: The stator has left hand threads.

INSPECTION: Inspect the stator for gouging and excessive wear. Contact FTI if you are questioning the condition of the stator.

INSTALLATION: Reverse the removal instructions found in this section.

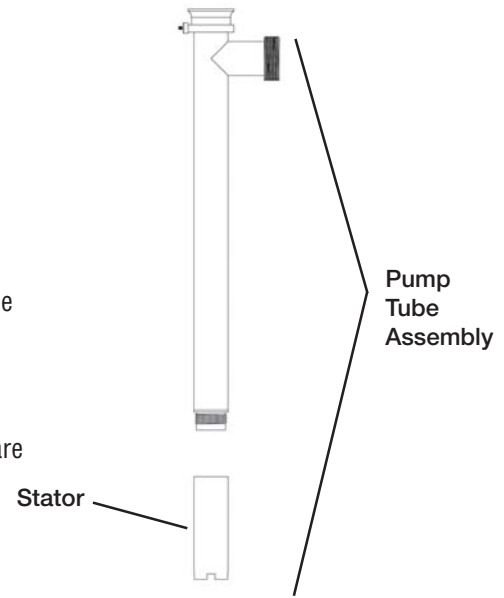

Figure 5

SECTION 5: SEAL REMOVAL, INSPECTION, AND INSTALLATION

REMOVAL:

1. Remove the motor (see section 1 and follow the instructions for your model).
2. Remove the drive assembly (see section 2).
3. The seal is located at the interface between the gearbox and the drive shaft (see Figure 6).
4. Secure the pump drive coupling using a pair of pliers.
5. Using a 3/4" open-end wrench, separate the drive shaft from the gearbox.
6. Being sure to protect the polished seal-seating area of the shaft, gently remove the rotating seal boot, spring, and spring retainer.
7. Using a thin bladed screwdriver, remove the stationary component of the seal from the gearbox assembly.

INSPECTION: Inspect the seal for wear and scratching.

INSTALLATION:

1. Lubricate the stationary seal face with a compatible lubricant and carefully install it into the gearbox housing.
2. Install the spring and spring retainer onto the pump shaft.
3. Lubricate the inside of the rotating seal boot with a chemically compatible lubricant and install it onto the pump shaft.
4. Reverse steps five through one of the seal removal instructions found in this section.

SECTION 6: HELPFUL HINTS FOR CLEANING THE PUMP

- Removing the drive assembly before removing the pump from the pumpage will allow fluid to back drain into the container.
- After flushing the internal components of the pump, be sure to lubricate the rotor.

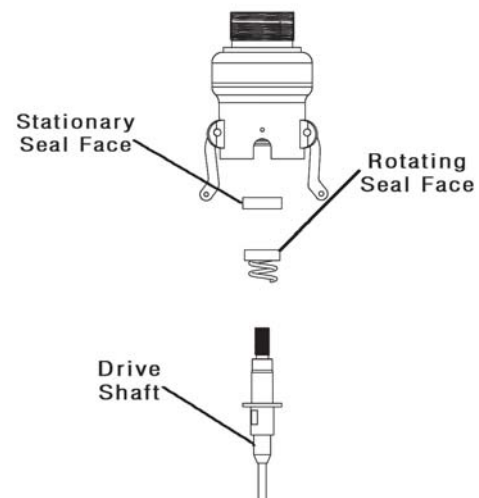
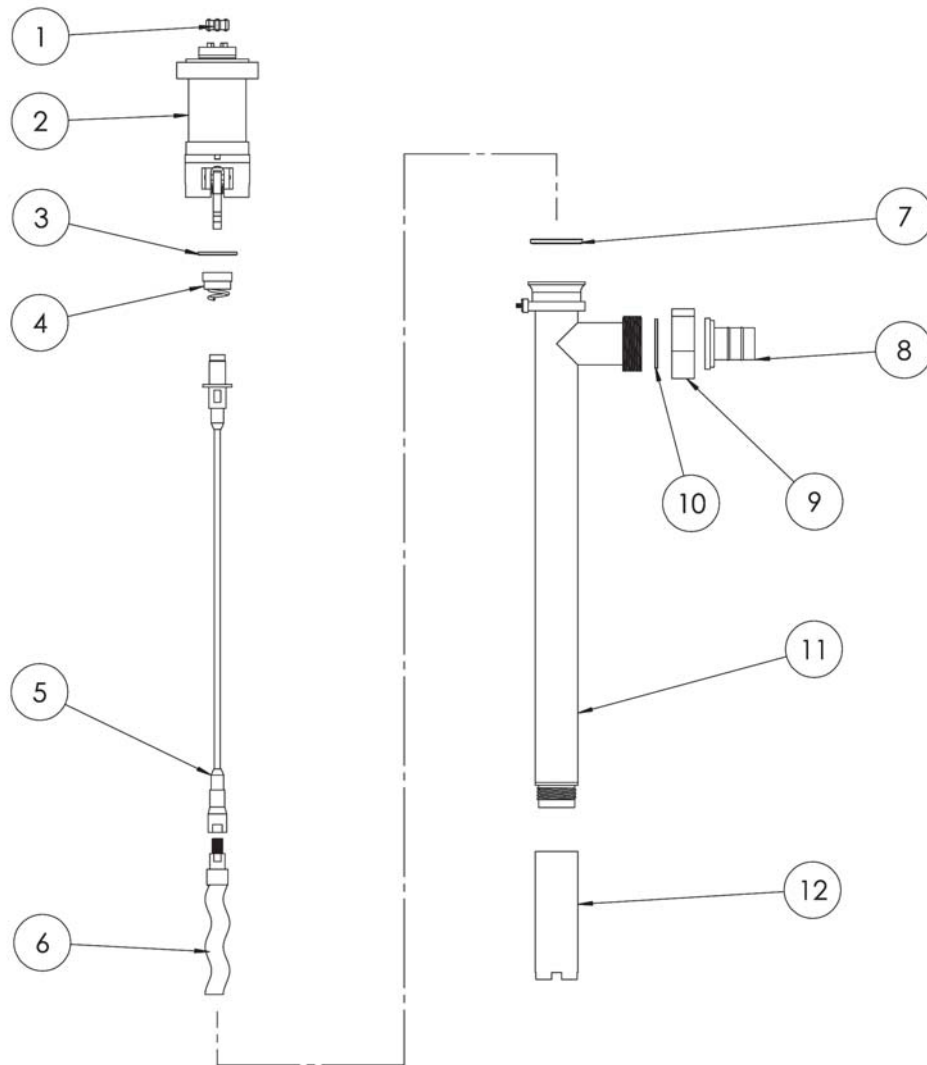

Figure 6

HVDP SERIES - HVDP-HR



ITEM	DESCRIPTION	PART NUMBER
1	Coupling Insert	J100014
2	HVDP-HR Gear Box Assembly 16:1	105150
3	Tube O--ring Viton	105080
3	Tube O-ring EPDM	105081
3	Tube O-ring Teflon Encap Sil	105082
4	Seal (carbon/ceramic/viton)	J102957-1
4	Seal (carbon/ceramic/EPDM)	J102957-2
4	Seal (carbon/ceramic/Kalrez)	J103081
4	Seal (silicon carbide/viton)	J103066
4	Seal (silicon carbide/EPDM)	J103067
5	HVDP 27 HR Shaft Assembly	105146-1
5	HVDP 40 HR Shaft Assembly	105146-2
5	HVDP 48 HR Shaft Assembly	105146-3
6	HVDP Rotor #1	105009-1
6	HVDP Rotor #2	105009-2
6	HVDP Rotor #3	105009-3

ITEM	DESCRIPTION	PART NUMBER
7	Cplg O-ring Viton	105083
7	Cplg O-ring EPDM	105084
7	Cplg O-ring Teflon Encap Sil	105085
8	HVDP Barbed Hose Adapter 1 1/2"	105176
8	HVDP Barbed Hose Adpater 2"	105287
9	Union Nut	105023
10	Discharge O-ring Viton	105077
10	Discharge O-ring EPDM	105078
10	Discharge O-ring Teflon Encap Sil	105079
11	HVDP 27 Intake Tube Assembly	105143-1
11	HVDP 40 Intake Tube Assembly	105143-2
11	HVDP 48 Intake Tube Assembly	105143-3
12	HVDP Buna Stator	105008-1
12	HVDP Viton Stator	105008-2
12	HVDP Teflon Stator	105008-3
	HVDP Bail Wire (not shown)	105032

HVDP SERIES - HVDP-LR

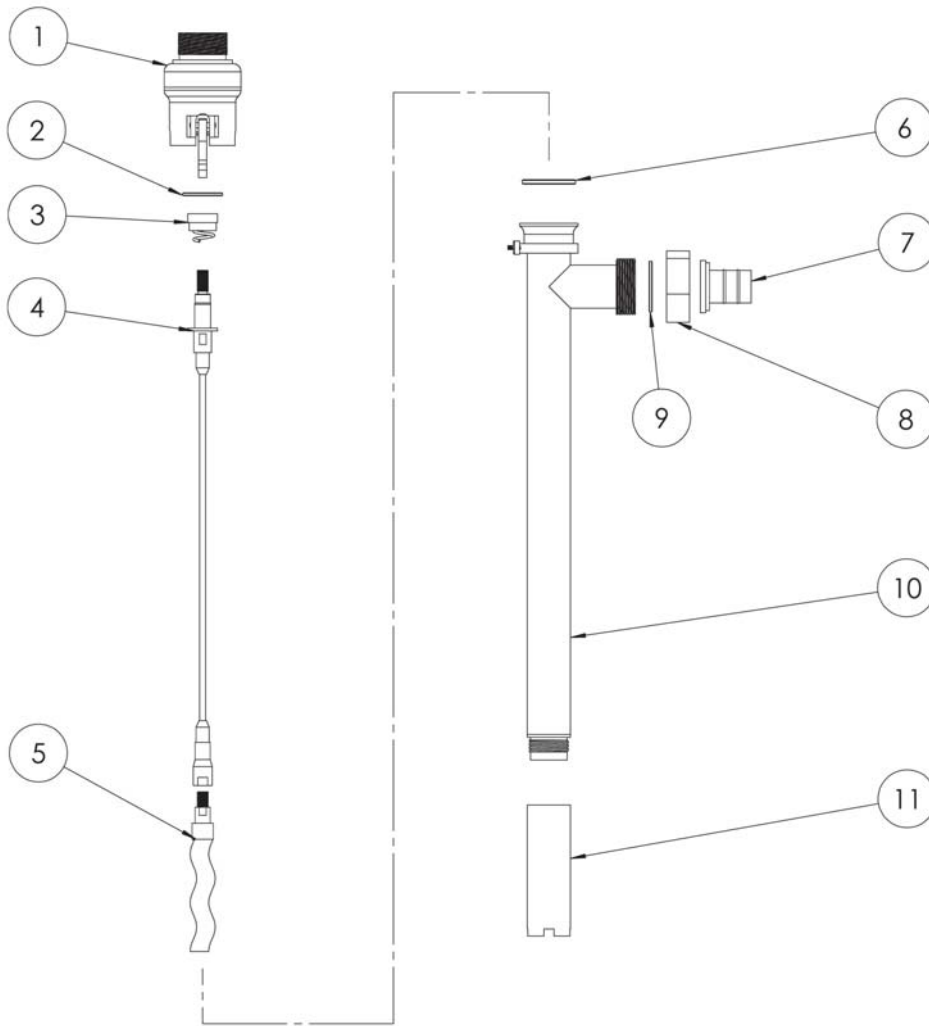

ITEM	DESCRIPTION	PART NUMBER
1	HVDP LR Gearbox Assembly 5:1	105154
1	HVDP LR Gearbox Assembly 4:1	105155
2	Tube O-ring Viton	105080
2	Tube O-ring EPDM	105081
2	Tube O-ring Teflon Encap Sil.	105082
3	Seal (carbon/ceramic/viton)	J102957-1
3	Seal (carbon/ceramic/EPDM)	J102957-2
3	Seal (carbon/ceramic/Kalrez)	J103081
3	Seal (silicon carbide/viton)	J103066
3	Seal silicon carbide/EPDM)	J103067
4	HVDP 27 LR Shaft Assembly	105147-1
4	HVDP 40 LR Shaft Assembly	105147-2
4	HVDP 48 LR Shaft Assembly	105147-3
5	HVDP Rotor #1	105009-1
5	HVDP Rotor #2	105009-2
5	HVDP Rotor #3	105009-3

ITEM	DESCRIPTION	PART NUMBER
6	Cplg O-ring Viton	105083
6	Cplg O-ring EPDM	105084
6	Cplg O-ring Teflon Encap Sil	105085
7	HVDP Barbed Hose Adapter 1 1/2"	105176
7	HVDP Barbed Hose Adapter 2"	105287
8	Union Nut	105023
9	Discharge O-ring Viton	105077
9	Discharge O-ring EPDM	105078
9	Discharge O-ring Tef Encap Sil	105079
10	HVDP 27 Intake Tube Assembly	105143-1
10	HVDP 40 Intake Tube Assembly	105143-2
10	HVDP 48 Intake Tube Assembly	105143-3
11	HVDP Buna Stator	105008-1
11	HVDP Viton Stator	105008-2
11	HVDP Teflon Stator	105008-3
*	HVDP Bail Wire (not shown)	105032

M58H & M59H 800W MOTORS

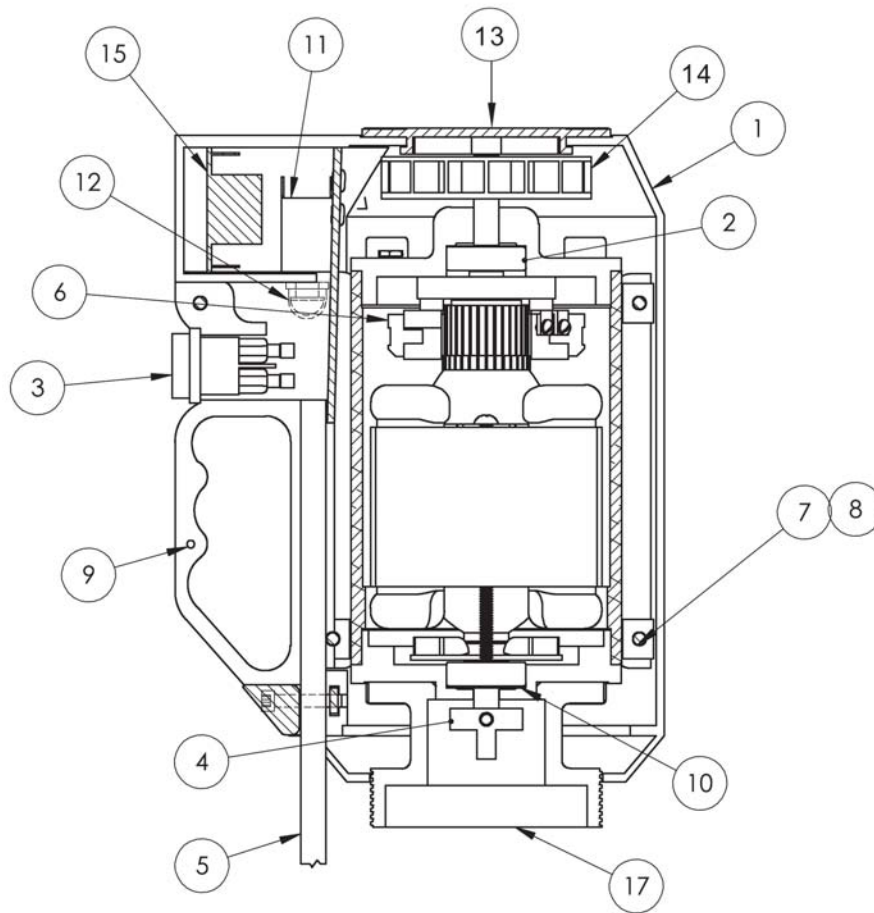

Item	Quantity		Description	Part Number
	M58	M59		
1	1	1	Housing Repair Kit	105144
2	2	2	Ball Bearing	J101069
3	1	1	Switch	J101143
4	1	1	Half Coupling	J100013
5	1	-	Cord Assembly	A101738
5	-	1	Cord Assembly	A101740
6	2	2	Brush Set	J101107
7	6	6	Housing Nut	J100990
8	6	6	Housing Bolt	J100023
9	3	3	Screw	J101530
10	1	1	Wave Washer	J101126
11	1	-	Circuit Breaker	J103796
12	-	1	Circuit Breaker	J101149
13	1	1	Cover	J100789
14	1	1	Fan	105102
15	1	-	Speed Control	105136
15	-	1	Speed Control	105062
16	1	1	Speed Control Knob	105063
17	1	1	Gearbox Adapter	105133



FINISH THOMPSON INC.

921 Greengarden Road • Erie, PA 16501-1591 U.S.A.
Ph 814-455-4478 • Fax 814-455-8518
Email fti@finishthompson.com • www.finishthompson.com

Service 1-800-888-3743
Literature ID No. FT03-875A
P/N J105362, Rev. 0, 7/03

