



AK / AV 4 & 5 SERIES Metallic Vertical Centrifugal Pumps Installation and Maintenance Instructions

ASSEMBLY

PUMPS WITH MOTORS

1. No assembly required. Simply unpack the pump and motor and examine for any signs of shipping damage. If damage is detected, save the packaging and notify the carrier immediately.
2. To install the pump into the system, follow the installation instructions provided.

PUMPS WITHOUT MOTORS

1. Unpack the pump and any supplied accessories and examine for damage. If damage is detected, save the packaging and notify the carrier immediately.
2. Lay the motor on its side. Install the slinger ring (item 2) onto the motor shaft. After coating the motor shaft threads with a thread lube, thread the pump shaft (item 8) onto the motor shaft about 3 full turns. Install the four set screws (item 6) in the motor end of the pump shaft, but do not tighten.
3. Gently place the motor on the fan cover so the pump shaft points straight up. Install the mounting plate (item 1) with the four locating tabs (these are welded on one side of the plate) facing the motor and locating on the raised motor face. Slide column assembly (item 7) over the pump shaft and attach to the motor with the four mounting bolts, flat washers and lock washers (items 5,3, 4) going through the column flange and the mounting plate.
4. Lay the pump on its side and remove the fan cover from the motor.
5. Holding the motor fan, adjust the pump shaft by threading clockwise or counterclockwise until the pump shaft shoulder is set correctly (see figure 1).

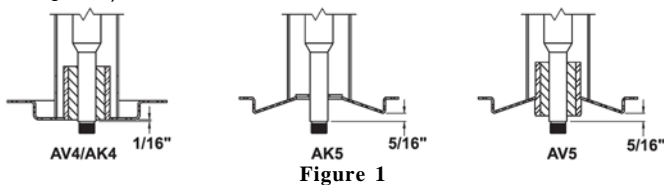

Figure 1

6. Tighten the setscrews in the pump shaft through the access hole at the motor end of the column assembly.
7. After applying a thread lube, thread the impeller (item 12) on until it bottoms out on the pump shaft shoulder. Install the 5/16 bolt, washer and lock washer (items 15, 13, 14) in the impeller end of the pump shaft.
8. On AK/AV 4 models, spin the fan blade and visually check to make sure all four impeller fins are not rubbing and are straight in relationship to the back head section of the column assembly. Gently adjust the fins if necessary.
9. Install the impeller housing (item 16) (without the o-ring) and hold in place with your hand. Spin the fan blade while listening and feeling for impeller rubbing. Pump shaft adjustment can be made if necessary.

10. Replace the motor fan cover and gently place the pump on the motor fan cover.
11. Clean the o-ring sealing area on the back head section of the column assembly and the impeller housing. Lubricate the o-ring (item 10) with a compatible lubricant.
12. Install the impeller housing and v-clamp (item 11). Impeller housings with the discharge attached need to be inserted into the hole in the mounting plate and visually aligned with the column assembly. Snug the nut on the v-clamp.
13. The alignment for the discharge can be adjusted by tapping the impeller housing discharge left or right with a rubber mallet. Visually check that the discharge is parallel to the column assembly and it goes through the mounting plate straight.
14. Once the discharge alignment is correct the v-clamp nut can be tightened.
15. Insert a 1/2" socket into the suction and spin the impeller to check clearances.
16. Install the pump into the system following the installation instructions provided.

INSTALLATION REQUIREMENTS

MOUNTING:

1. Base plate must be securely fastened so that there is no vibration when the pump is running.
2. Align the piping with the pump ports. Do not connect the piping until it is aligned properly and supported independently. Do not pull the piping in line with the pump or support the piping with the pump.
3. A valve should be installed in the discharge line. During initial operation of the pump, determine the power consumed. If necessary, throttle back the flow until the pump draws the rated horsepower of the motor.

PIPING TO AND FROM THE PUMP:

- Always support the piping near the pump to minimize stress and strain.
- Minimize frictional losses by increasing the piping size by one diameter.
- Use a minimum number of bends, keeping any bends a minimum distance of ten pipe diameters from the pump.
- Install a valve on the discharge line to control the flow. Place the valve within a distance of ten pipe diameters from the pump.
- Ensure that the pump is leak free.
- Maintain a flooded suction at all times. Use a float switch to turn off the pump at low level.

⚠ CAUTION: Suction prime must be maintained at all times. Running the pump dry will cause damage to the pump components. To protect the pump if prime is lost, use a pressure switch on the discharge or a motor power monitor to monitor motor current draw.

Figure 2

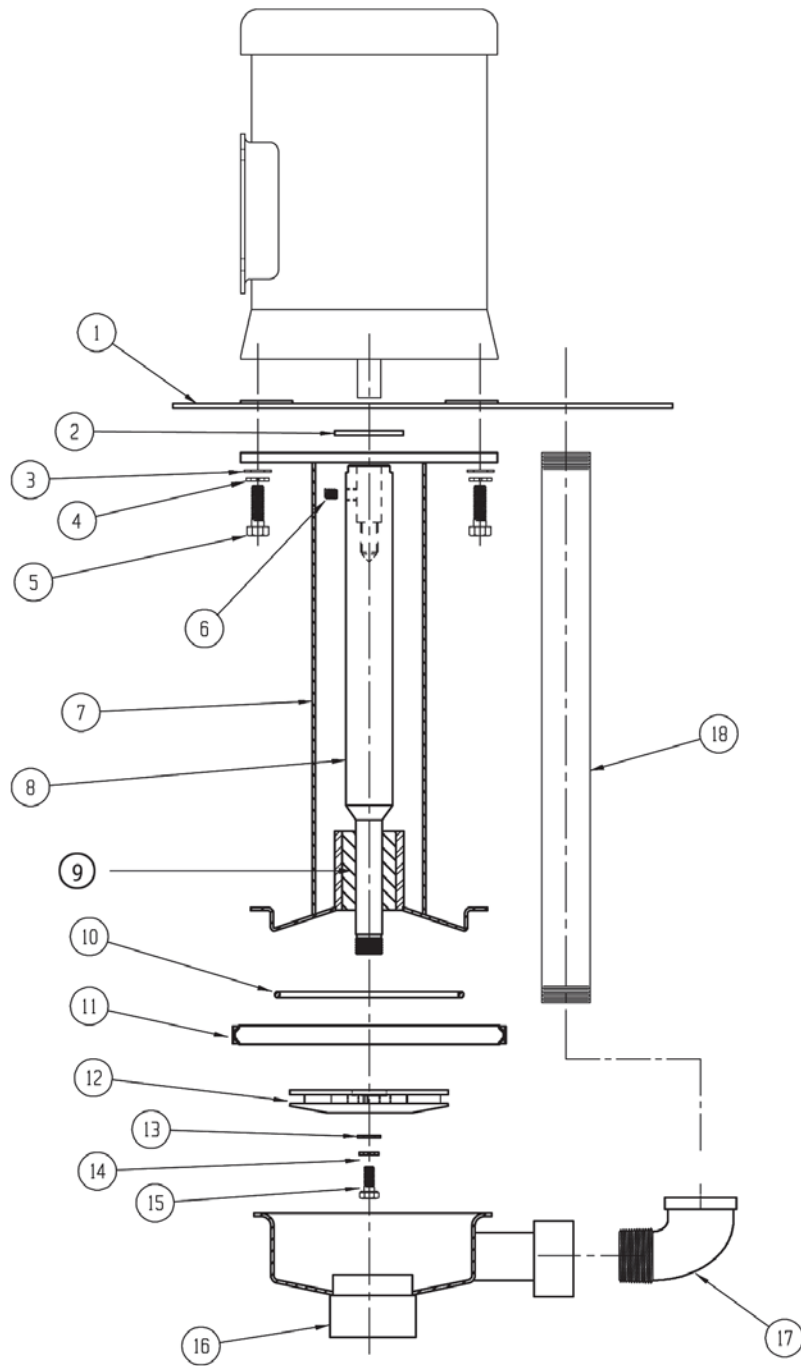

AK/AV 4 & 5 PARTS LIST

Item	Qty.	Description	AK/AV4 P/N	AK/AV5 P/N
1	1	Mounting plate – 316SS – 10" x 15"	A102134-1	A102134-2
		Mounting plate – 316SS – High Head		A102134-1
2	1	Slinger ring	M100115	M100115
3	4	Flat washer – SS – 3/8"	J100128	J100128
4	4	Lock washer – SS – 3/8"	J100115	J100115
5	4	Hex head bolt – SS – 3/8-16 x 1-1/4	J103118	J103118
6	4	Set Screw – SS- 5/16-18 x 3/8"	J104219	J104219
7	1	AK4 – 12" – column assembly	A102139-1	
		AV4 – 12" – column assembly	A102137-1	
		AV4 – 24" – column assembly	A102137-2	
		AV4 – 36" - column assembly	A102137-3	
		AK5 – 12" – column assembly		A102177
		AV5 – 12" – column assembly		A102143-1
		AV5 – 24" – column assembly		A102143-2
		AV5 – 36" – column assembly		A102143-3
8	1	AK4 – 12" shaft – 316SS	M101889-1	
		AV4 – 12" shaft – 316SS	M101889-1	
		AV4 – 24" shaft – 316SS	M101889-2	
		AV4 – 36" shaft – 316SS	M101889-3	
		AK5 – 12" shaft – 316SS		M101896-1
		AV5 – 12" shaft – 316SS		M101896-1
		AV5 – 24" shaft – 316SS		M101896-2
		AV5 – 36" shaft – 316SS		M101896-3
9	1	Lower bushing – carbon	J103025	J103025
		Lower bushing – Viton®	M102336-1	M102336-1
		Lower bushing – EPDM	M102336-2	M102336-2
10	1	Housing o-ring – Viton	J102946	J102960
		Housing o-ring – EPDM	J103004	J103003
		Housing o-ring – Teflon	J103042	J103043
11	1	V-clamp	J102947	J102947
12	1	AK/AV4 impeller 3" – 316SS	A102105-1	
		AK/AV4 impeller 3-1/4" – 316SS	A102105-2	
		AK/AV4 impeller 3-1/2" – 316SS	A102105-3	
		AK/AV5 impeller 4" x 1/4" vane 316SS standard		A102114-1
		AK/AV5 impeller 4-1/4" x 1/4" vane 316SS standard		A102114-2
		AK/AV5 impeller 4-1/2" x 1/4" vane 316SS standard		A102114-3
		AK/AV5 impeller 4-3/4" x 1/4" vane 316SS standard		A102114-4
		AK/AV5 impeller 4" x 3/8" vane 316SS high flow		A102114-9
		AK/AV5 impeller 4-1/4" x 3/8" vane 316SS high flow		A102114-10
		AK/AV5 impeller 4-1/2" x 3/8" vane 316SS high flow		A102114-11
		AK/AV5 impeller 4-3/4" x 3/8" vane 316SS high flow		A102114-12
		AK/AV5 impeller 3" 316SS recessed		A102105-1
		AK/AV5 impeller 3-1/4" 316SS recessed		A102105-2
		AK/AV5 impeller 3-1/2" 316SS recessed		A102105-3
		AK/AV5 impeller 3-3/4" 316SS recessed		A102105-4
		AK/AV5 impeller 4-1/2" 316SS recessed		A102105-5
		AV5 impeller 4-3/4" 316SS high head		A102183
13	1	Flat washer – SS – 5/16"	J101293	J101293
14	1	Lock washer – SS – 5/16"	J102282	J102282
15	1	Hex head bolt – SS – 5/16-18 x 3/4	J103196	J103196
16	1	AK/AV4 impeller housing – 316SS – 3/4" x 1/2" std. open	A102106-1	
		AK/AV5 impeller housing – 316SS – 1-1/2" x 1-1/4" std. enc.		A102112-1
		AK/AV5 impeller housing – 316SS – 1-1/2" x 1-1/4" rec. imp.		A102112-2
		AV5 impeller housing – 316SS – 1/2" x 1/4" high head		A102120-1
17	1	AK/AV4 street elbow – 316SS – 1/2"	J101912	
		AK/AV5 street elbow – 316SS – 1-1/4"		J103049
		AV5 street elbow – 316SS – 1/4" high head		J101908
18	1	AK/AV4 discharge tube – 316SS – 12"	M101891-1	
		AV4 discharge tube – 316SS – 24"	M101891-2	
		AV4 discharge tube – 316SS – 36"	M101891-3	
		AK/AV5 discharge tube – 316SS – 12" x 1-1/4"		M101897-1
		AV5 discharge tube – 316SS – 24" x 1-1/4"		M101897-2
		AV5 discharge tube – 316SS – 36" x 1-1/4"		M101897-3
		AV5 discharge tube – 316SS – 12" x 1/4" high head		M101897-4
		AV5 discharge tube – 316SS – 24" x 1/4" high head		M101897-5
		AV5 discharge tube – 316SS – 36" x 1/4" high head		M101897-6

ELECTRICAL CONNECTIONS:

1. Perform the motor wiring according to NEC requirements and local electrical codes.
2. Wire the motor for clockwise rotation when facing the fan end of the motor.
3. To verify correct motor rotation:
 - a. Install the pump into the system.
 - b. Fully open the suction and the discharge valves.
 - c. Allow fluid to flow into the pump. Do not allow the pump to run dry, as this will cause damage to pump components.
 - d. Jog the motor (allow it to run for only one to two seconds) and observe the rotation of the motor fan. Refer to the directional arrow on the pump if needed.

Note: A pump running backwards will pump, but a greatly reduced flow and pressure.

⚠ CAUTION: Do not run the pump dry. This pump should never be started without liquid in the casing. This could damage the pump. The fluid being transferred by the pump lubricates the pump components. Even short periods of dry running could cause pump damage. It is recommended that run dry protection be used. Optional electrical power monitors are available to help protect against run dry.

OPERATION

1. Partially open the discharge valves.
2. Start the pump and verify liquid is flowing. If there is no liquid flow, refer to the "Troubleshooting" section of these instructions.
3. Adjust the flow rate and pressure by regulating the discharge valve.

TROUBLESHOOTING

NO OR INSUFFICIENT FLOW:

1. No liquid in the sump
2. Closed valve.
3. Viscosity too high.
4. Discharge head higher than anticipated.
5. Suction too close to the bottom of the sump.

INSUFFICIENT PRESSURE:

1. Air or gasses in liquid.
2. Discharge head higher than anticipated.

EXCESSIVE POWER CONSUMPTION:

1. Head lower than rating.
2. Specific gravity or viscosity of liquid is too high.

EXCESSIVE VIBRATION:

1. Loose piping or bolts.
2. Suction too close to the bottom of the sump.

WARRANTY

Finish Thompson, Inc (manufacturer) warrants this product to be free of defects in materials and workmanship for a period of 180 days from date of purchase by original purchaser. If a warranted defect, which is determined by manufacturer's inspection, occurs within this period, it will be repaired or replaced at the manufacturer's option, provided (1) the product is submitted with proof of purchase date and (2) transportation charges are prepaid to the manufacturer. Liability under this warranty is expressly limited to repairing or replacing the product or parts thereof and is in lieu of any other warranties, either expressed or implied. This warranty does apply only to normal wear of the product or components. This warranty does not apply to products or parts broken due to, in whole or in part, accident, overload, abuse, chemical attack, tampering, or alteration. The manufacturer accepts no responsibility for product damage or personal injuries sustained when the product is modified in any way. If this warranty does not apply, the purchaser shall bear all cost for labor, material and transportation.

Manufacturer shall not be liable for incidental or consequential damages including, but not limited to process down time, transportation costs, costs associated with replacement or substitution products, labor costs, product installation or removal costs, or loss of profit. In any and all events, manufacturer's liability shall not exceed the purchase price of the product and/or accessories.

CHEMICAL REACTION DISCLAIMER

The user must exercise primary responsibility in selecting the product's materials of construction, which are compatible with the fluid(s) that come(s) in contact with the product. The user may consult Finish Thompson, Inc. (manufacturer) and a manufacturer's representative/distributor agent to seek a recommendation of the product's material of construction that offers the optimum available chemical compatibility.

However neither manufacturer nor agent shall be liable for product damage or failure, injuries, or any other damage or loss arising out of a reaction, interaction or any chemical effect that occurs between the materials of the product's construction and fluids that come into contact with the product's internals.

ORDERING SPARE PARTS

Spare parts can be ordered from your local distributor. Always refer to the pump model number to avoid error.

OTHER FINISH THOMPSON PRODUCTS

Finish Thompson manufactures a diverse range of pumps including drum/barrel fluid transfer, plastic or metallic magnetic drive and plastic or stainless steel mechanical sealed centrifugal pumps. For more information on these products visit our web site at www.finishthompson.com or contact your local distributor.

Call our Technical Service Hot Line, 1-800-888-3743, if you have any questions regarding product operation or repair.



FINISH THOMPSON INC.
921 Greengarden Road • Erie, PA 16501-1591 U.S.A.
Ph 814-455-4478 • Fax 814-455-8518
Email fti@finishthompson.com • www.finishthompson.com

SERVICE 800-888-3743
J103017, Rev. 5
FT01-842D, 4/05

