

PF Series Installation and Maintenance Instructions

Installation

Remove the drum pump and motor from its packaging and inspect for shipping damage. Remove the quality tag from the top of the pump and spin the pump coupling to verify there is no binding. Verify the housing cover (item 21) is on tight (it has a left hand thread). Remove the black rubber coupling insert (item 1) from the attached plastic bag, and install it onto the pump coupling. Adjust the coupling so that the empty slots in the insert are at 3 and 9 o'clock with the pump discharge at 12 o'clock. Remove the 2 mounting bolts from the motor/motor mount and adjust the motor coupling so that the coupling prongs are at 3 and 9 o'clock with the handle (on electric motors), or the air supply line (on air motors) at 6 o'clock. Install the motor onto the drum pump until it seats all the way down with the couplings connecting and install the 2 mounting bolts with nuts. Attach discharge hose and install into the container.

Maintenance disassembly --

1. Remove the housing cover (item 21) by turning it clockwise (left hand thread) while gripping the impeller housing (item 18).
2. Spin the impeller until a hole in the shaft can be seen through the square slot in the impeller housing (item 18), and insert 3/32 pin into the hole. Holding the pin, turn the impeller (item 20) counterclockwise (right hand thread) and remove it.
3. Remove the impeller housing (item 18) by gripping the intake tube and spinning the housing clockwise (left hand thread). Re-insert the 3/32 pin and while gripping the pump coupling unthread (counterclockwise) and remove the shaft (item 19) from the bearing assembly (item 3).
4. On PFP & PFV models, place the pump head (item 5) in a vise (do not crush) and remove the intake tube (item 9) by unthreading clockwise (left hand thread). Remove the inner upper (item 11) and lower (item 15) tubes from the head. Remove the bearing assembly (item 3) and the vapor seal (item 4) from the head.
5. On PFS models – place a wooden board or rubber mat on the floor (to protect the threads on the bottom of the tube) and gently tap the intake tube on it until the upper (item 11) and lower (item 15) tubes drop out. Remove the bearing assembly (item 3) and vapor seal (item 4) from the head.
6. Remove the center bearing (item 13) from the upper (item 11) and lower (item 15) tubes.

Inspection

1. Check the housing cover (item 21), the impeller (item 20), and the impeller housing (item 18) for wear, rubbing, or damage from foreign objects. Replace if damaged. Note –The double impeller design of this pump is dependant on the impeller working correctly. Any damage to the impeller can cause pump failure.
2. Inspect the pump shaft (item 19) for wear in the bottom (item 16), center bearing (item 13) and the vapor seal (item 4) areas. Replace the shaft if needed.
3. Inspect the bottom bearing (item 16), center bearing (item 13), and the bearing guide (item 14) for internal wear. Inspect all o-rings (items 17,12, & 10) for nicks or chemical attack. Replace as needed.
4. Inspect the bearing assembly (item 3) for rust or corrosion. Never reuse the vapor seal.

Reassembly

1. Install new vapor seal (item 4) into the pump head with the grooved side facing the bottom of the pump.
2. Thread the shaft (item 19) into the bearing assembly (item 3) with the 3/32 hole in the shaft on the other end. Carefully insert the shaft straight through the vapor seal (to avoid seal damage) from the top and seat the bearing assembly (item 3) into the pump head.
3. If o-rings are replaced -- install 2 center bearing o-rings (items 12) in the grooves, then slide the bearing guide on and then the remaining 2 o-rings. Install 2 upper inner tube o-rings (items 10), and install the impeller housing o-ring (item 17) inside the top of the housing. Apply a small amount of Vaseline to the o-rings to aid in assembly. Assemble the center bearing (item 13) into the upper (item 11) and lower (item 15) inner tubes.
4. On PFP / PFV models – Slide the inner tube assemble up the shaft and into the counter bore in the bottom of the head. Slide the intake tube up from the bottom, centering the bearing guide, and thread it into the head (left hand thread).
5. On PFS models – With the pump on a bench, slide the inner tube assembly onto the shaft (centering the bearing guide) until it stops. Slide the impeller housing over the shaft, center the bottom of the lower inner tube into the counter bore in the top of the impeller housing, and push / thread into the intake tube bottom (left hand thread).
6. Gripping the coupling at the top of the pump, thread the impeller on (right hand thread). Install the housing cover (left hand thread). Spin the coupling to verify there is no binding inside the pump.

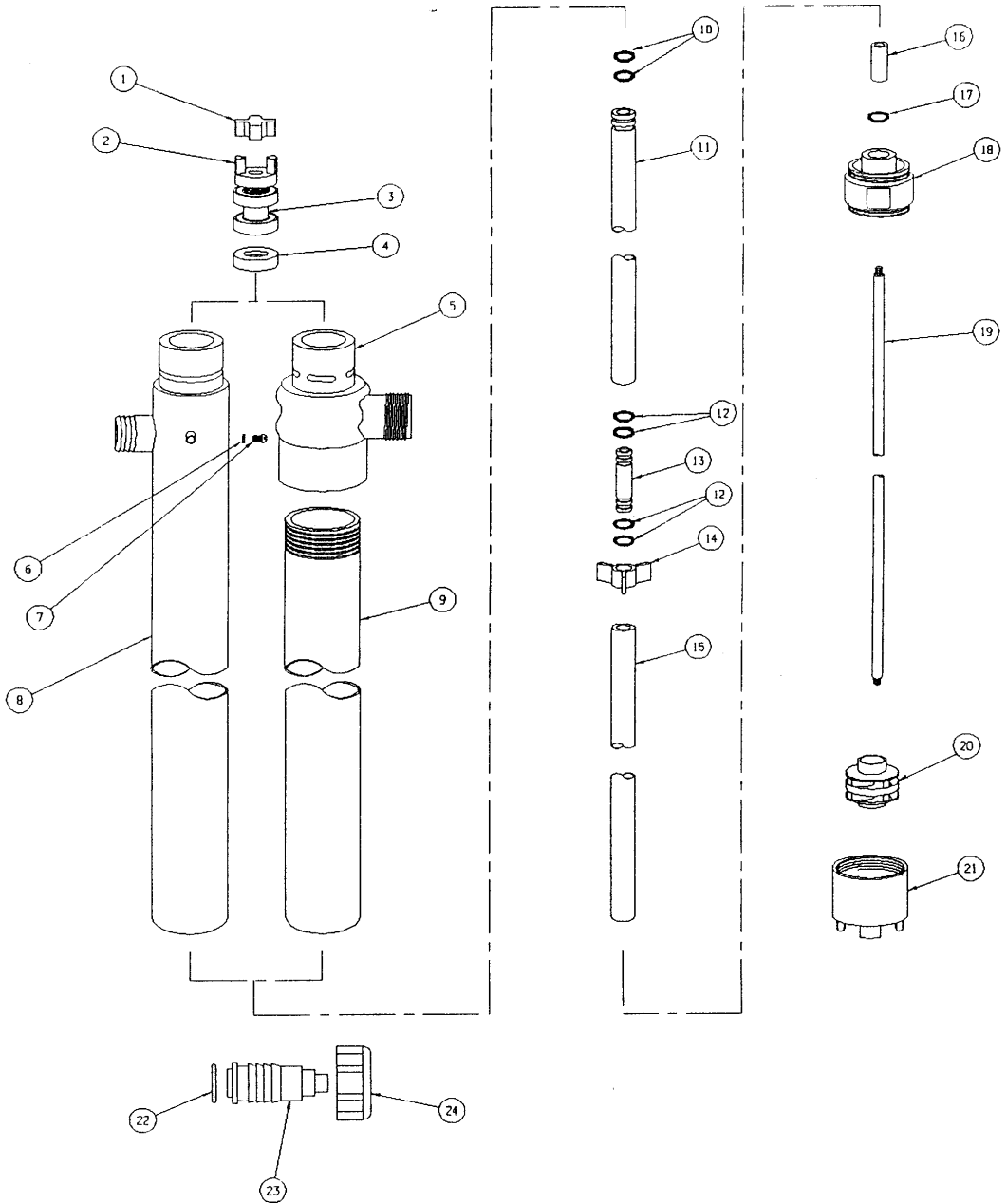

Item	Description	Part Number		
		PFV (PolyPro)	PFV (PVDF)	PFS (SS)
1	Coupling Insert	J100014	J100014	J100014
2	Half Coupling	J100012	J100012	J100012
3*	Bearing Assembly	A101110	A101110	A101110
4*	PF Vapor Seal	M100008	M100008	M100008
5	PF Head	M100866-1	M100866-2	—
6	#8 Brass Lock Washer	—	—	J100823
7	#8-32 x 1/4 Pan HD M/S Brass	—	—	J100822
8	PFS 27 Intake Tube Assembly	—	—	A101725-1
"	PFS 40 Intake Tube Assembly	—	—	A101725-3
"	PFS 48 Intake Tube Assembly	—	—	A101725-4
9	PF 27 Intake Tube	M100005-1	M100005-5	—
"	PF 40 Intake Tube	M100005-3	M100005-6	—
"	PF 48 Intake Tube	M100005-4	M100005-7	—
"	PF 60 Intake Tube	M100005-8	—	—
10	Upper Inner Tube O-Ring	J100249	J100249	J100249
11	PF 27 Upper Inner Tube	M100050-1	M100050-5	M100786-1
"	PF 40 Upper Inner Tube	M100050-3	M100050-6	M100786-3
"	PF 48 Upper Inner Tube	M100050-4	M100050-7	M100786-4
"	PF 60 Upper Inner Tube	M100050-8	—	—
12	Center Bearing O-Ring	J100018	J100018	J100018
13*	Center Bearing	M100010	M100010	M100010
14*	PF Bearing Guide	M101603-2	M101603-1	M101603-3
15	PF 27 Lower Inner Tube	M100003-1	M100003-5	M100789-1
"	PF 40 Lower Inner Tube	M100003-3	M100003-6	M100789-3
"	PF 48 Lower Inner Tube	M100003-4	M100003-7	M100789-4
"	PF 60 Lower Inner Tube	M100003-8	—	—
16*	Bottom Bearing	M100007	M100007	M100007
17	Impeller Housing O-Ring	J100019	J100019	J100019
18*	PF Impeller Housing	M100018-1	M100018-2	M101696
19	PF 27 Main Shaft	M100004-1	M100004-1	M100004-5
"	PF 40 Main Shaft	M100004-3	M100004-3	M100004-7
"	PF 48 Main Shaft	M100004-4	M100004-4	M100004-8
"	PF 60 Main Shaft	M100004-9	—	—
20*	PF Impeller Assembly	A100002-2	A100002-2	A100002-3
21*	PF Housing Cover	M101612-1	M101612-2	M100726
22	Discharge O-Ring	J100991	J100991	—
23	PF Spout	M100028-1	M100028-2	—
24	PF Discharge Nut	M101610-1	M101610-2	—

NOTE: The PFP ships with a variable orifice. To vary flow, trim steps.
Step 1 restricts flow to 10 gpm
Step 2 - 20 gpm
Step 3 - 30 gpm
Step 4 is the maximum opening