

EP Series

D R U M P U M P S

EP Series - Drum Pumps

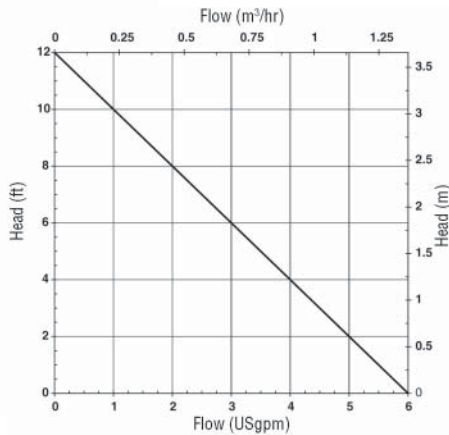
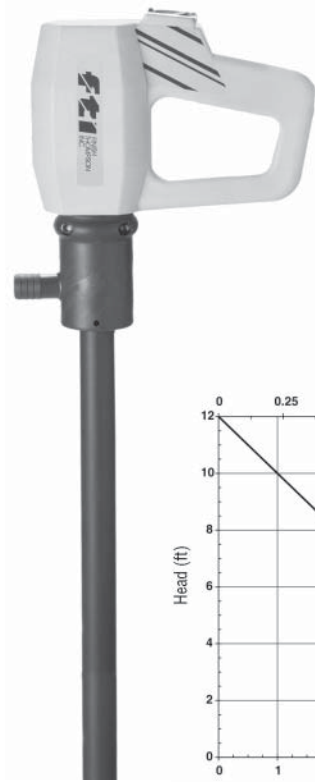

The Econo Pump (EP) is both labor and cost efficient. It is the best value drum pump on the market. Designed to replace hand pumps or awkward air operated diaphragm pumps, it is extremely lightweight and easy to handle. The combination of corrosion-resistant polypropylene tube and an electric or air motor makes it a perfect choice for intermittent duty, chemical transfer applications.

Tube Features

- Best Buy
- Corrosion resistant polypropylene tube
- Portable and light weight - 5 lbs (2.3 kg)
- **Intermittent duty**
- Rugged construction for industrial use
- 27" (69 cm) and 40" (102 cm) tubes

Electric Motor Features

- Splashproof
- Ergonomic handle
- Push-button operation
- Impact resistant
- 50/60 Hz
- 120 or 220/240 VAC



M57
Air Motor

Performance

- Maximum 1.2 SG
- Maximum temperature - 120°F (49°C)
- 6 gpm (1.36m³/hr.) maximum
- 12 feet (3.7 m) maximum head
- Maximum viscosity 150 cP

Tube Specifications

MODEL	TUBE					SEAL	SHAFT	INTERNALS	HOSE SIZE REQUIRED	
	MATERIAL	DIAMETER		LENGTH					in	mm
		in	mm	in	cm					
EPP-S	Polypropylene	1	25	27	69	Graphite filled PTFE	316 SS	Polypropylene, PTFE, Viton, PVDF	3/4	20
EPP-I				40	102		Alloy 625			

Motor Specifications

MODEL	TYPE	CERTIFICATIONS	ELECTRICAL REQUIREMENTS	OUTPUT	RPM
M54	Splashproof, IP44, Double Insulated	CE	220-240VAC/50-60Hz	100 w	10,000
M55	Splashproof, IP44, Double Insulated	CSA	120VAC/60Hz	1/7 HP	10,000
M56	Splashproof, IP44, Double Insulated	CE	120VAC/50-60Hz	100 w	10,000
M57	Air	CE	No electrical requirements	1/2 HP	300-6,000

NOTE: The Econo Pump is not for use with flammables or pumping in hazardous locations.



FINISH THOMPSON INC.

921 Greengarden Road • Erie, PA 16501-1591 U.S.A.
Ph 814-455-4478 • Fax 814-455-8518

Email fti@finishthompson.com • www.finishthompson.com

Toll Free USA/Canada 1-800-934-9384
I.D. No. - FT98-711G, 3-25-04

