

---

# KC & VKC SERIES CURVEBOOK

---

Effective May 1, 2001

Catalog ID #FT01-833D, Rev. 4, 8-11-03

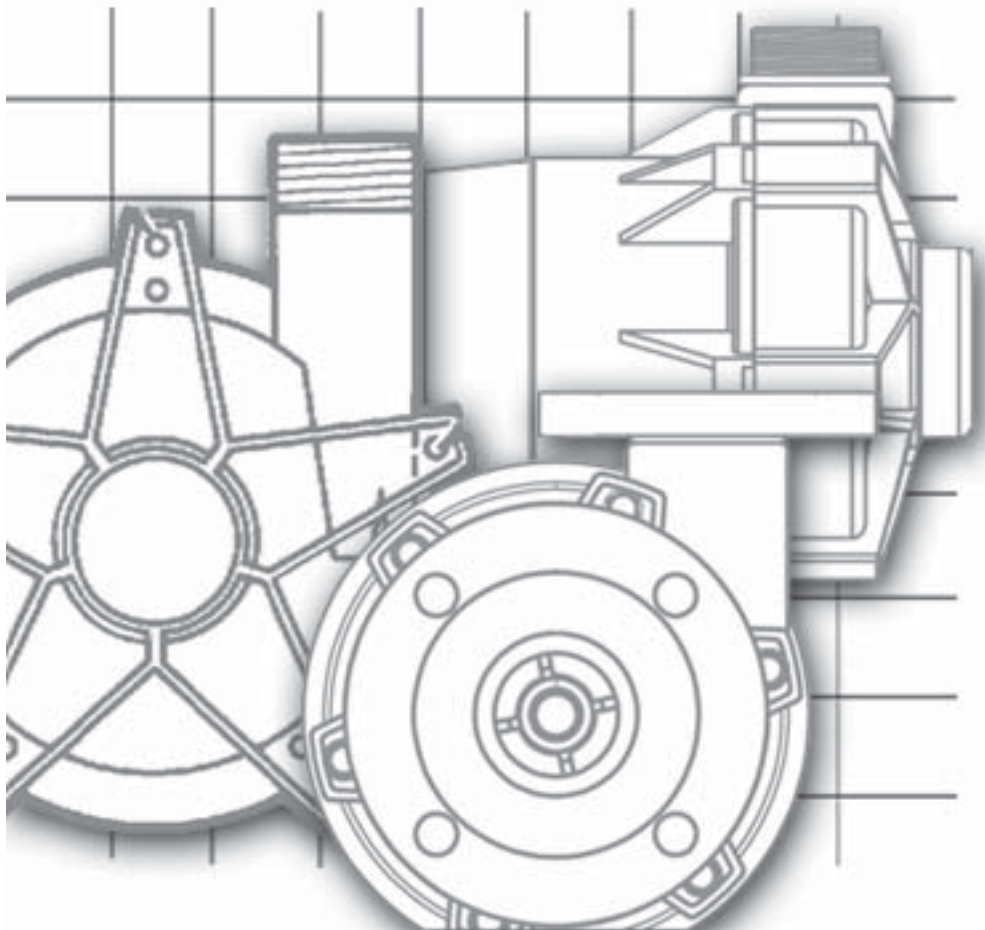



# TABLE OF CONTENTS

## MODEL KC 3,4, 5 SERIES

3450 rpm, 60 Hz, 1" FNPT x 1/2" MNPT -----	4
2850 rpm, 50 Hz, 1" FNPT X 1/2" MNPT -----	5

## MODEL KC/VKC 5.5/6 SERIES

3450 rpm, 60 Hz, 1" FNPT X 3/4" MNPT -----	6
1725 rpm, 60 Hz, 1" FNPT X 3/4" MNPT -----	7
2900 rpm, 50 Hz, 1" FNPT X 3/4" MNPT -----	8
1450 rpm, 50 Hz, 1" FNPT X 3/4" MNPT -----	9

## MODEL KC/VKC 6H Series

3450 rpm, 60 Hz, 1" FNPT X 3/4" MNPT -----	10
1725 rpm, 60 Hz, 1" FNPT X 3/4" MNPT -----	11
2900 rpm, 50 Hz, 1" FNPT X 3/4" MNPT -----	12
1450 rpm, 50 Hz, 1" FNPT X 3/4" MNPT -----	13

## MODEL KC/VKC 7 Series

3450 rpm, 60 Hz, 1-1/2" FNPT X 1" MNPT -----	14
1725 rpm, 60 Hz, 1-1/2" FNPT X 1" MNPT -----	15
2900 rpm, 50 Hz, 1-1/2" FNPT X 1" MNPT -----	16
1450 rpm, 50 Hz, 1-1/2" FNPT X 1" MNPT -----	17

## MODEL KC/VKC 8/10 SERIES

3450 rpm, 60 Hz, 1-1/2" FNPT X 1" MNPT -----	18
1725 rpm, 60 Hz, 1-1/2" FNPT X 1" MNPT -----	19
2900 rpm, 50 Hz, 1-1/2" FNPT X 1" MNPT -----	20
1450 rpm, 50 Hz, 1-1/2" FNPT X 1" MNPT -----	21

## MODEL KC/VKC 11 SERIES

3450 rpm, 60 Hz, 1-1/2" FNPT X 1-1/4" MNPT -----	22
1725 rpm, 60 Hz, 1-1/2" FNPT X 1-1/4" MNPT -----	23
2900 rpm, 50 Hz, 1-1/2" FNPT X 1-1/4" MNPT -----	24
1450 rpm, 50 Hz, 1-1/2" FNPT X 1" MNPT -----	25

## MODEL KC/VKC 22 SERIES

Open, 3450 rpm, 60 Hz, 2" FNPT (3" flange) x 2" MNPT (2" flange) -----	26
Open, 1725 rpm, 60 Hz, 2" FNPT (3" flange) x 2" MNPT (2" flange) -----	27
Open, 2900 rpm, 60 Hz, 2" FNPT (3" flange) x 2" MNPT (2" flange) -----	28
Open, 1450 rpm, 60 Hz, 2" FNPT (3" flange) x 2" MNPT (2" flange) -----	29
Closed, 3450 rpm, 60 Hz, 2" FNPT (3" flange) x 2" MNPT (2" flange) -----	30
Closed, 1725 rpm, 60 Hz, 2" FNPT (3" flange) x 2" MNPT (2" flange) -----	31
Closed, 2900 rpm, 50 Hz, 2" FNPT (3" flange) x 2" MNPT (2" flange) -----	32
Closed, 1450 rpm, 50 Hz, 2" FNPT (3" flange) x 2" MNPT (2" flange) -----	33

## MULTI STAGE SERIES

3450 rpm, 60 Hz, 1-1/2" FNPT x 1" MNPT -----	34
1725 rpm, 60 Hz, 1-1/2" FNPT x 1" MNPT -----	35
2900 rpm, 50 Hz, 1-1/2" FNPT x 1" MNPT -----	36
1450 rpm, 50 Hz, 1-1/2" FNPT x 1" MNPT -----	37

## SELF PRIMING

KC11 3450 rpm, 60 Hz -----	38
KC11 1725 rpm, 50 Hz -----	39
KC11 2900 rpm, 50 Hz -----	40
KC11 3450 rpm, 60 Hz Priming Time/Lift Curve -----	41
KC11 1725 rpm, 60 Hz Priming Time/Lift Curve -----	42
KC11 2900 rpm, 50 Hz Priming Time/Lift Curve -----	43



# KC SERIES STANDARD HORIZONTAL PERFORMANCE CURVE

**MODEL KC3/4/5**

**3450 rpm, 60 Hz**

**Suction: 1" FNPT**

**Discharge: 1/2" MNPT**

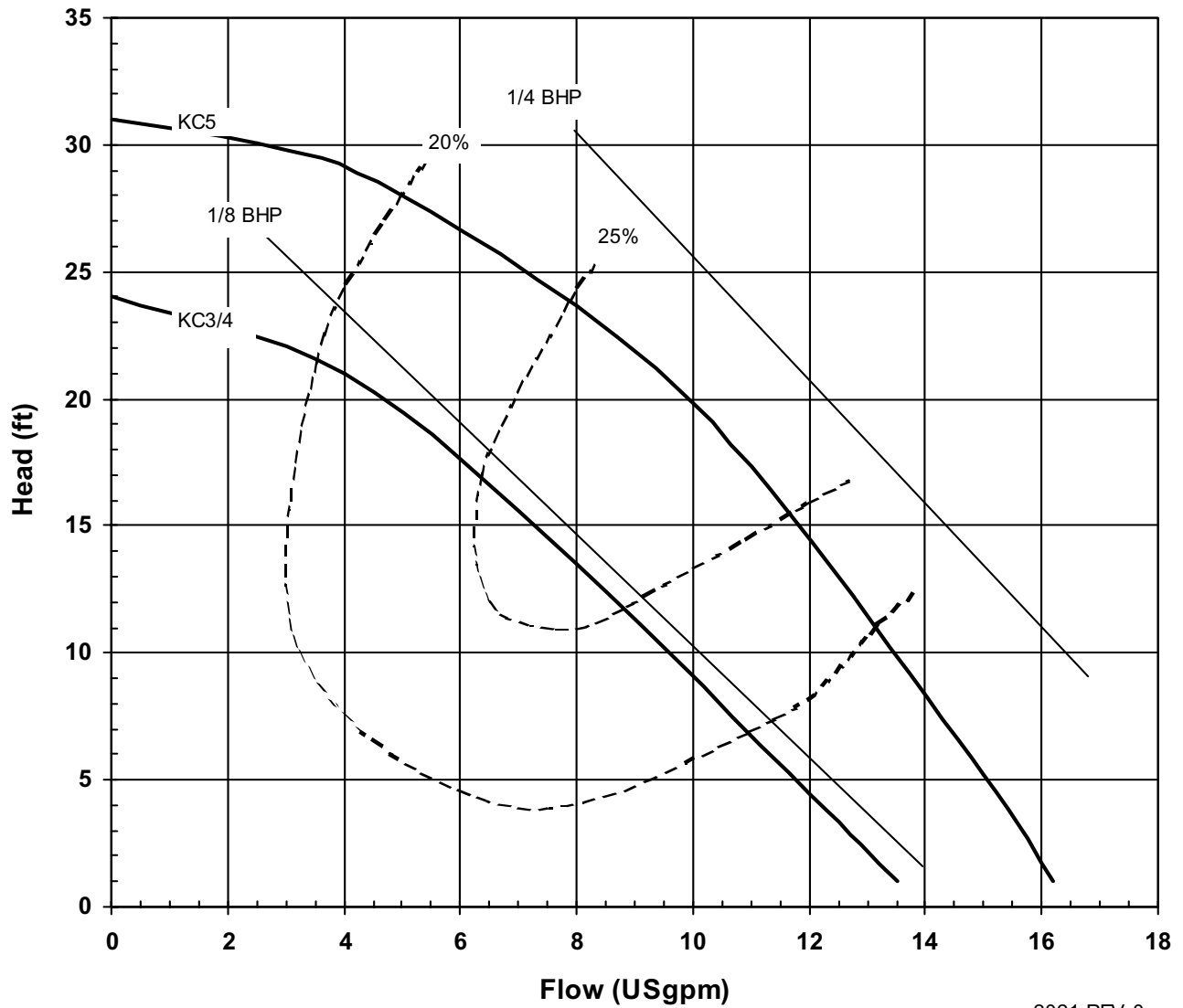

2021 REV 0  
01/08/01



**KC SERIES  
STANDARD HORIZONTAL  
PERFORMANCE CURVE**

**MODEL KC3/4/5**

2850 rpm, 50 Hz

Suction: 1" FNPT

Discharge: 1/2" MNPT

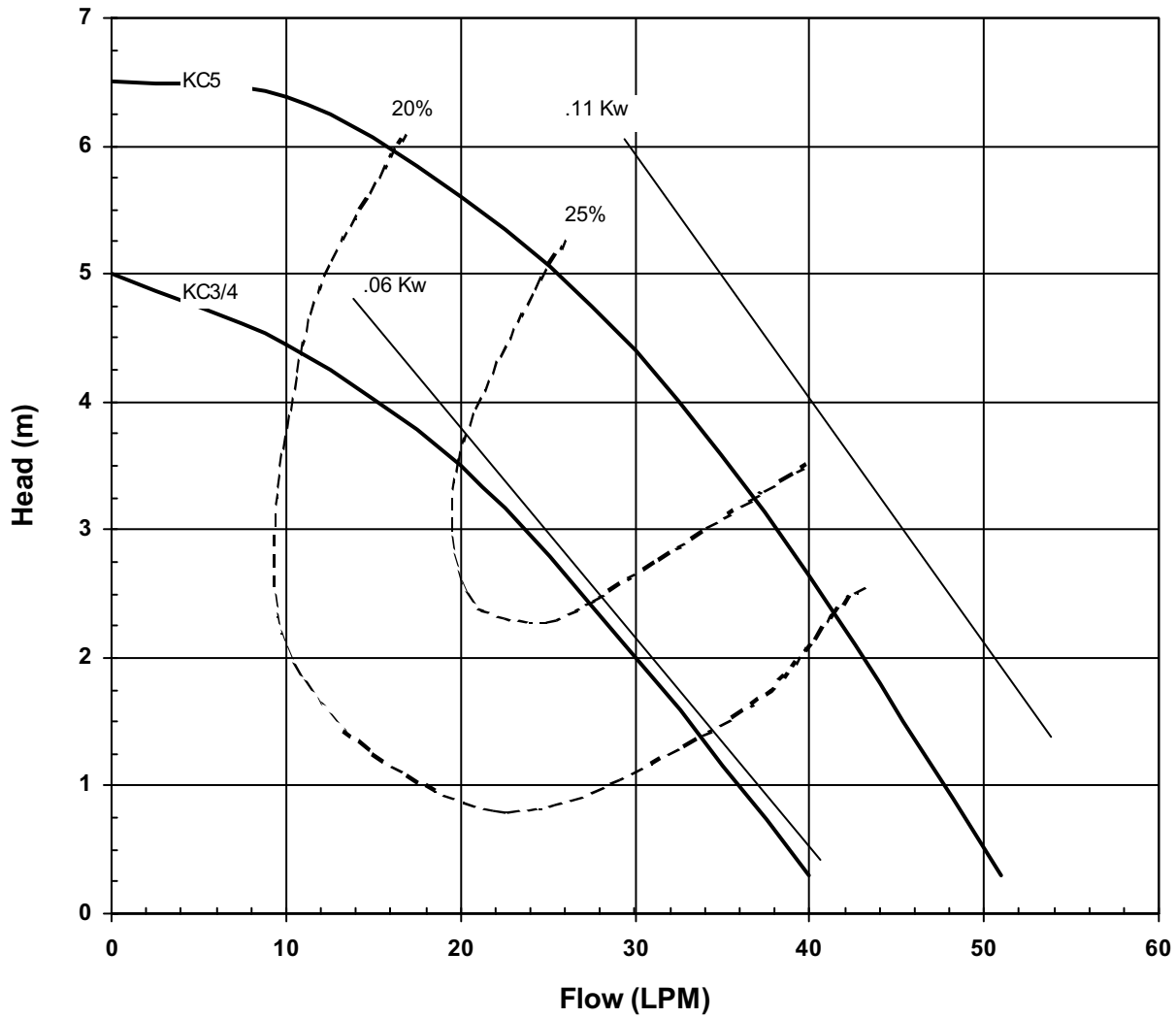

2022 REV 0  
01/08/01



KC/VKC SERIES  
STANDARD  
PERFORMANCE CURVE

MODEL KC5.5/6  
VKC5.5/6  
3450 rpm, 60 Hz  
Suction: 1" FNPT  
Discharge: 3/4" MNPT

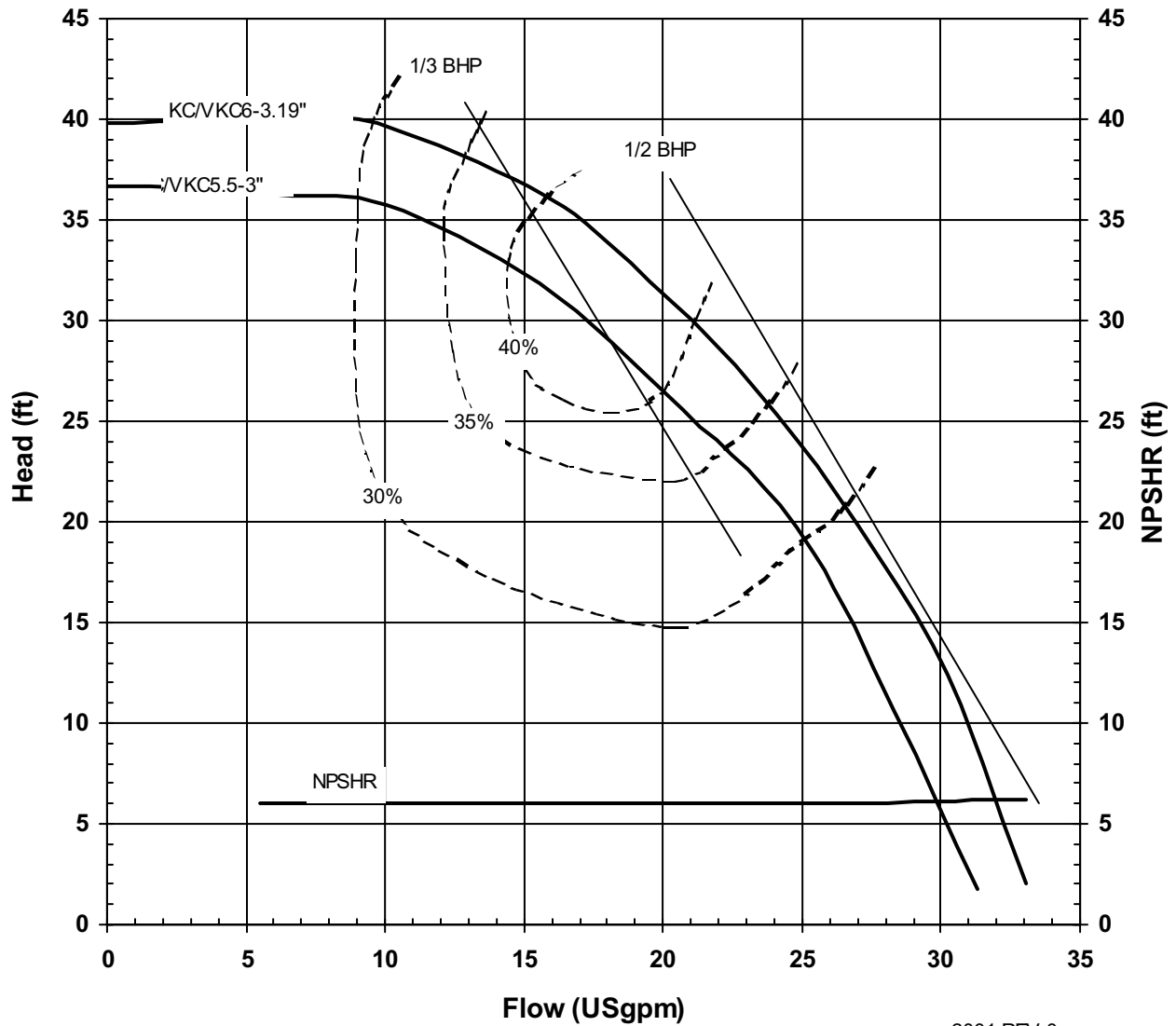

2001 REV 0  
12/08/00



KC/KC SERIES  
STANDARD  
PERFORMANCE CURVE

MODEL KC5.5/6  
VKC 5.5/6  
1725 rpm, 60 Hz  
Suction: 1" FNPT  
Discharge: 3/4" MNPT

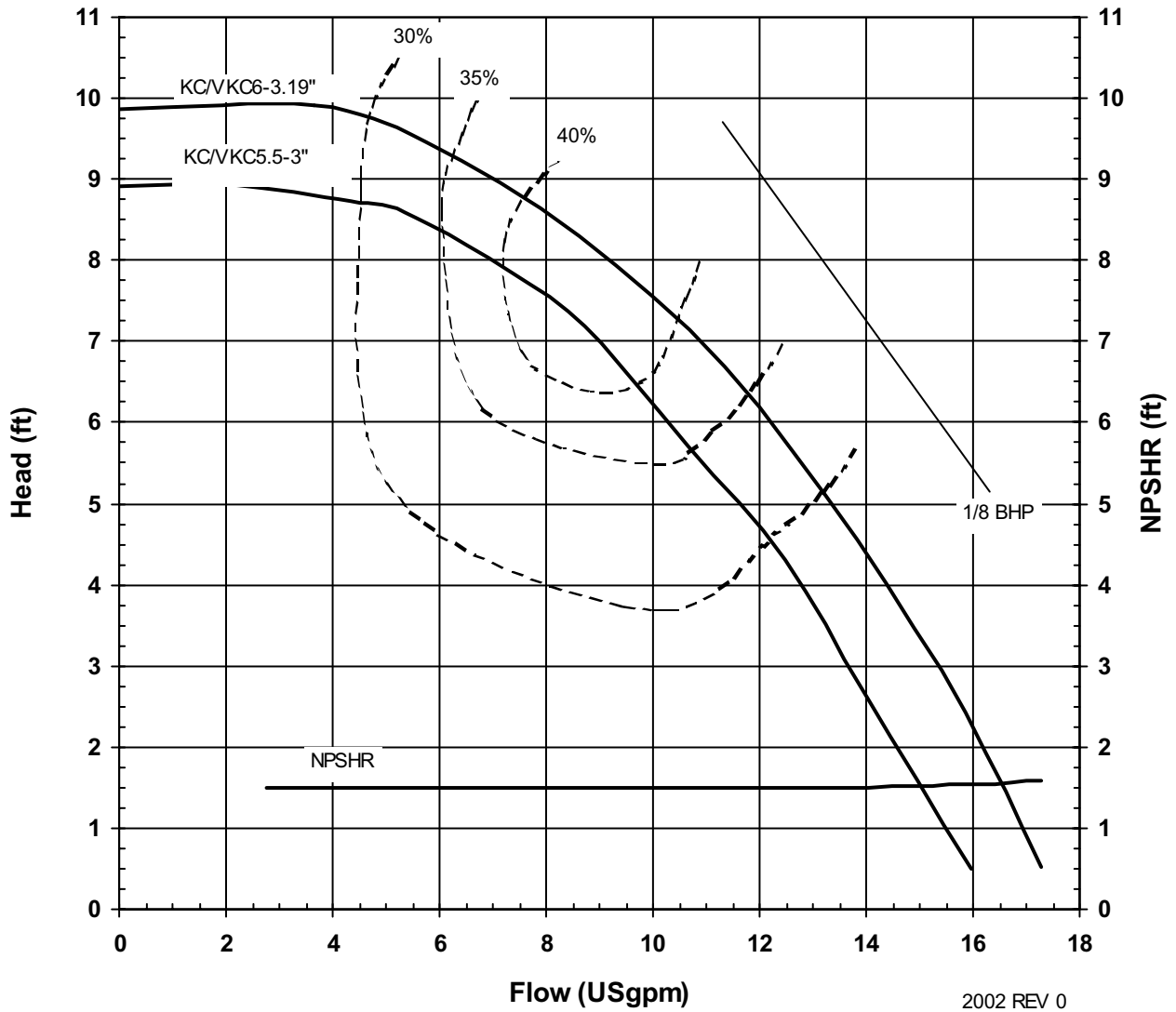

2002 REV 0  
12/08/00



KC/VKC SERIES  
STANDARD  
PERFORMANCE CURVE

MODEL KC5.5/6  
VKC5.5/6  
2900 rpm, 50 Hz  
Suction: 1" FNPT  
Discharge: 3/4" MNPT

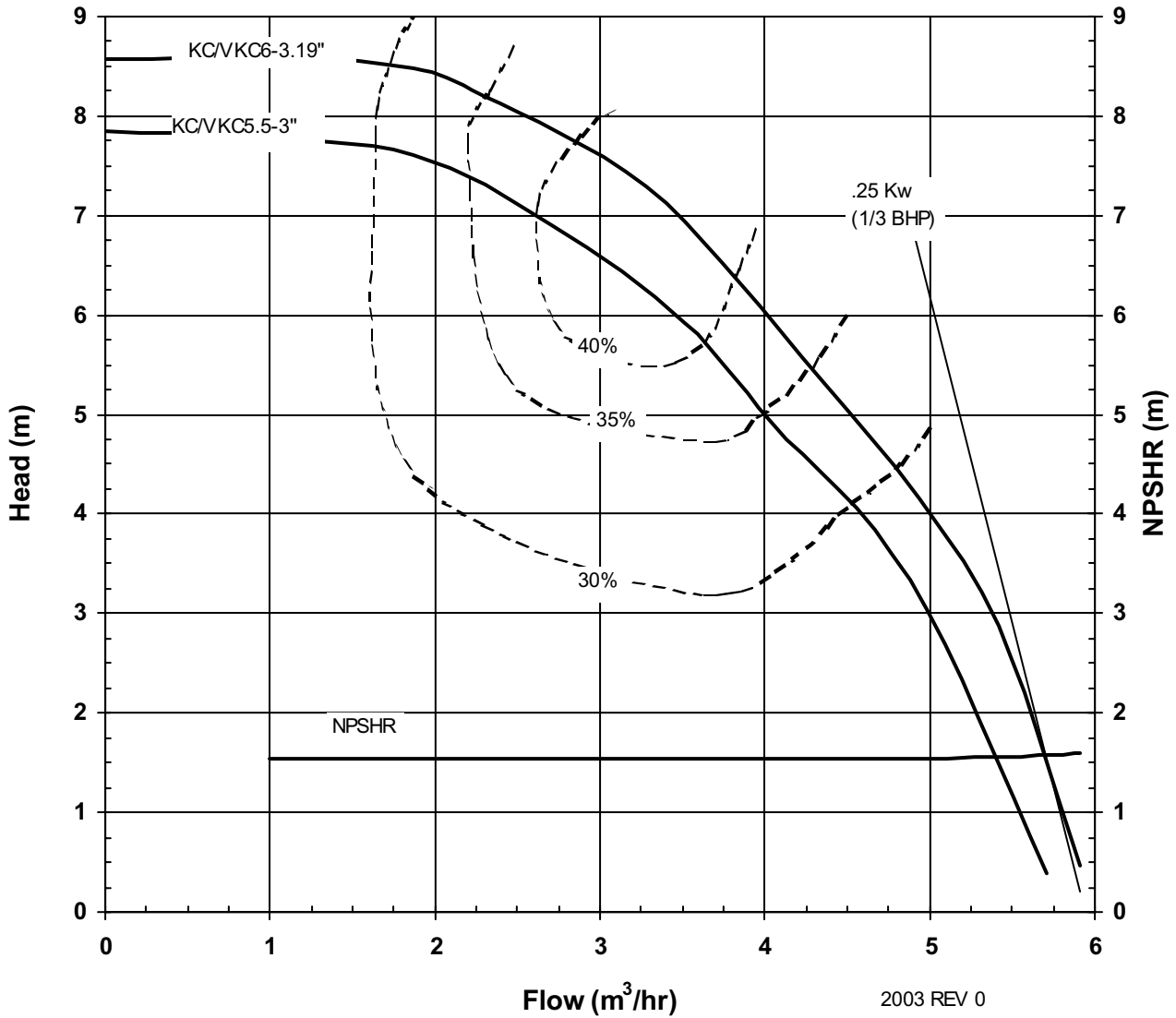

2003 REV 0  
12/08/00



KC/VKC SERIES  
STANDARD  
PERFORMANCE CURVE

MODEL KC5.5/6  
VKC5.5/6  
1450 rpm, 50 Hz  
Suction: 1" FNPT  
Discharge: 3/4" MNPT

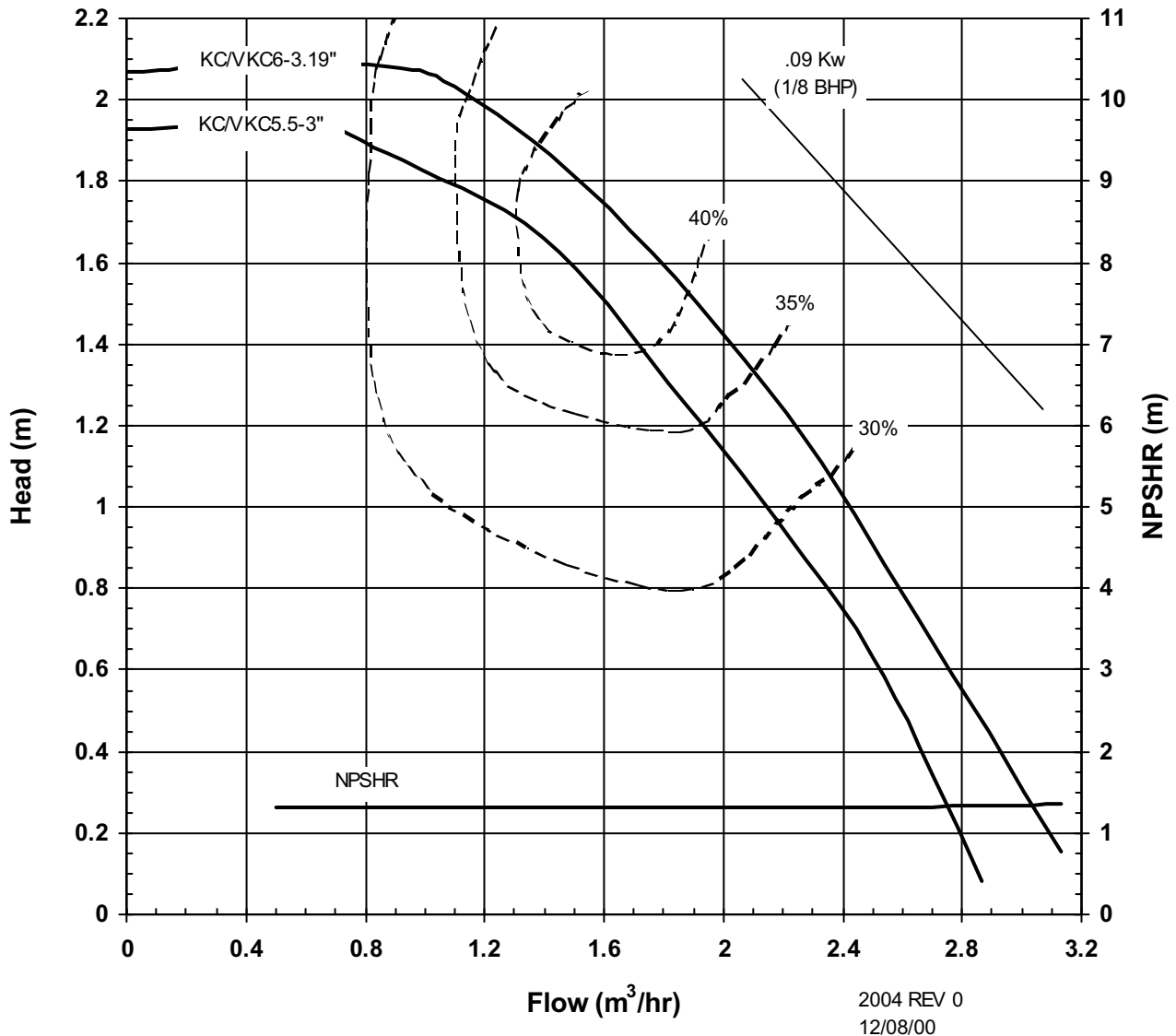



KC/VKC SERIES  
STANDARD  
PERFORMANCE CURVE

MODEL KC6H  
VKC6H

3450 rpm, 60 Hz

Suction: 1" FNPT

Discharge: 3/4" MNPT

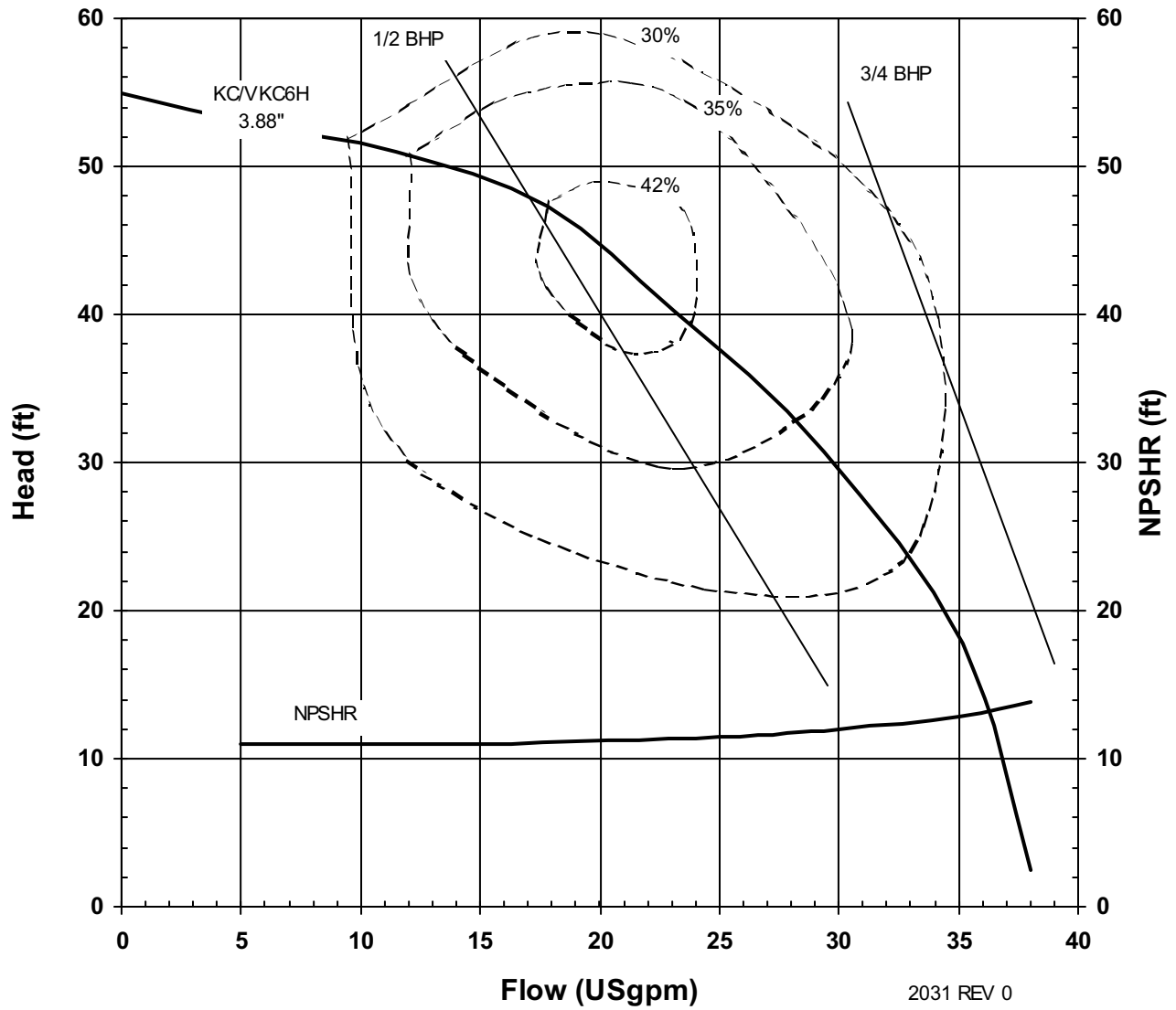

2031 REV 0  
5/11/01



KC/VKC SERIES  
STANDARD  
PERFORMANCE CURVE

MODEL KC6H  
VKC6H

1725 rpm, 60 Hz  
Suction: 1" FNPT  
Discharge: 3/4" MNPT

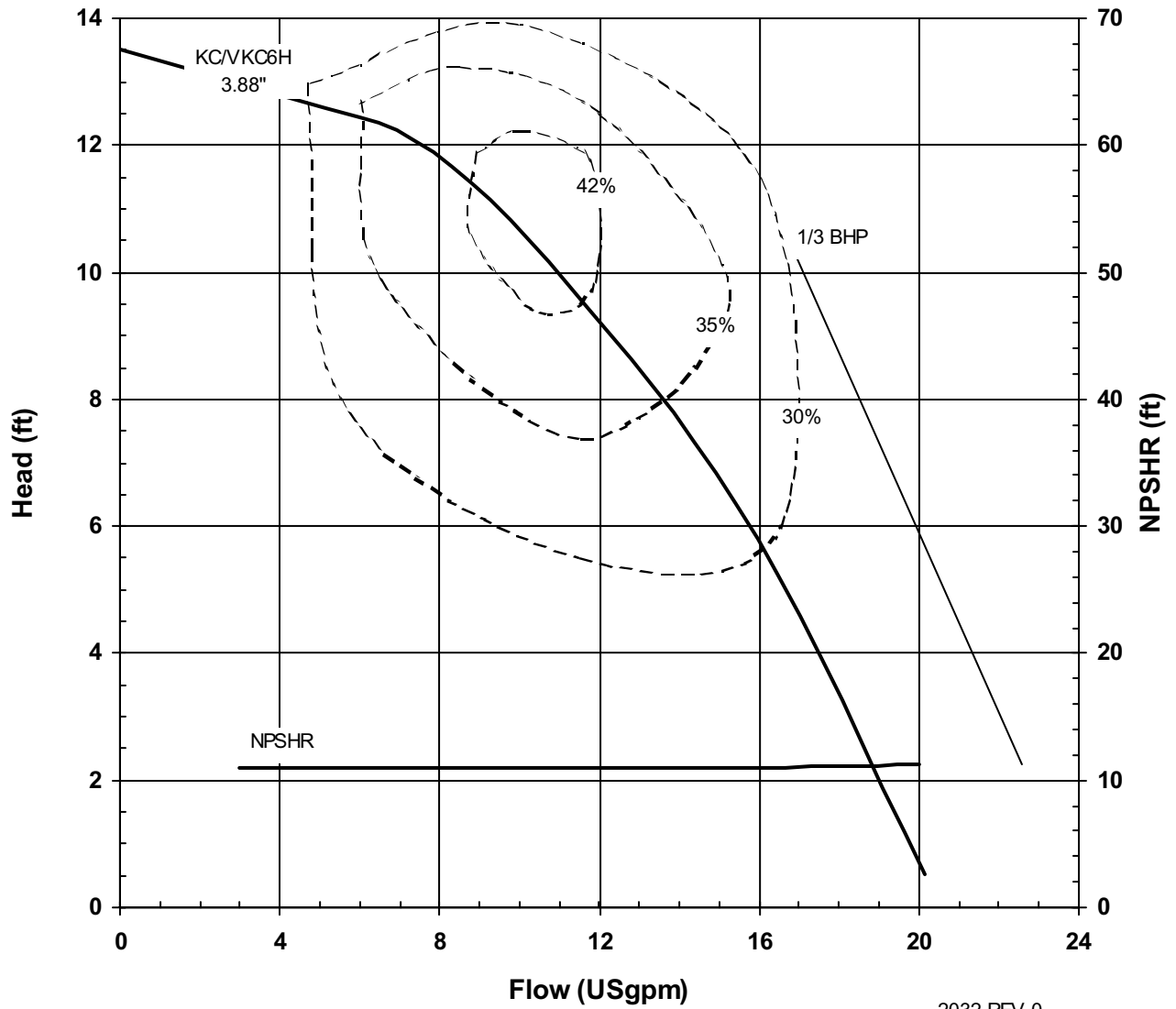

2032 REV 0  
5/11/01



KC/VKC SERIES  
STANDARD  
PERFORMANCE CURVE

MODEL KC6H  
VKC6H

2900 rpm, 50 Hz  
Suction: 1" FNPT  
Discharge: 3/4" MNPT

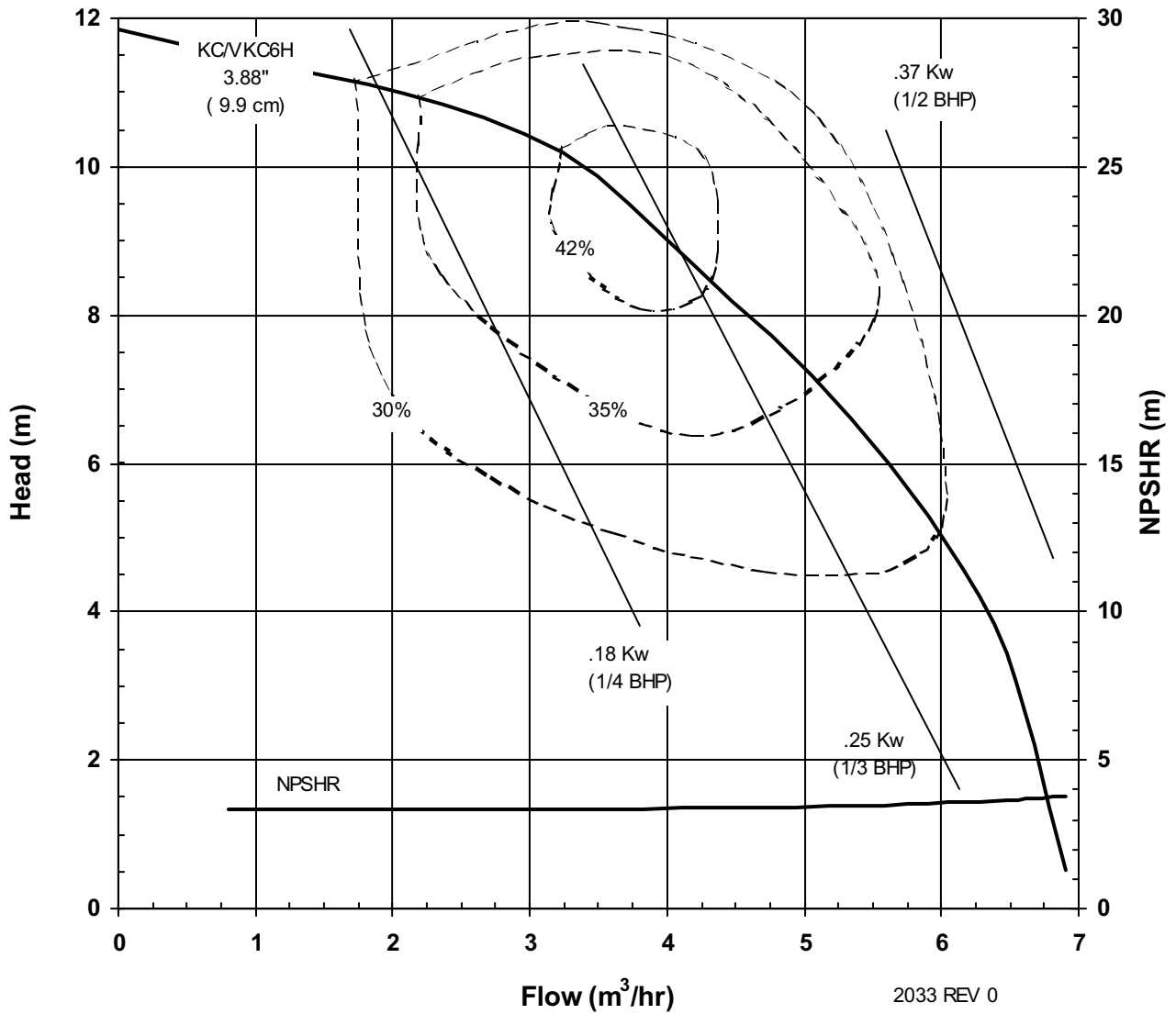

2033 REV 0  
5/11/01



KC/VKC SERIES  
STANDARD  
PERFORMANCE CURVE

MODEL KC6H  
VKC6H

1450 rpm, 50 Hz  
Suction: 1" FNPT  
Discharge: 3/4" MNPT

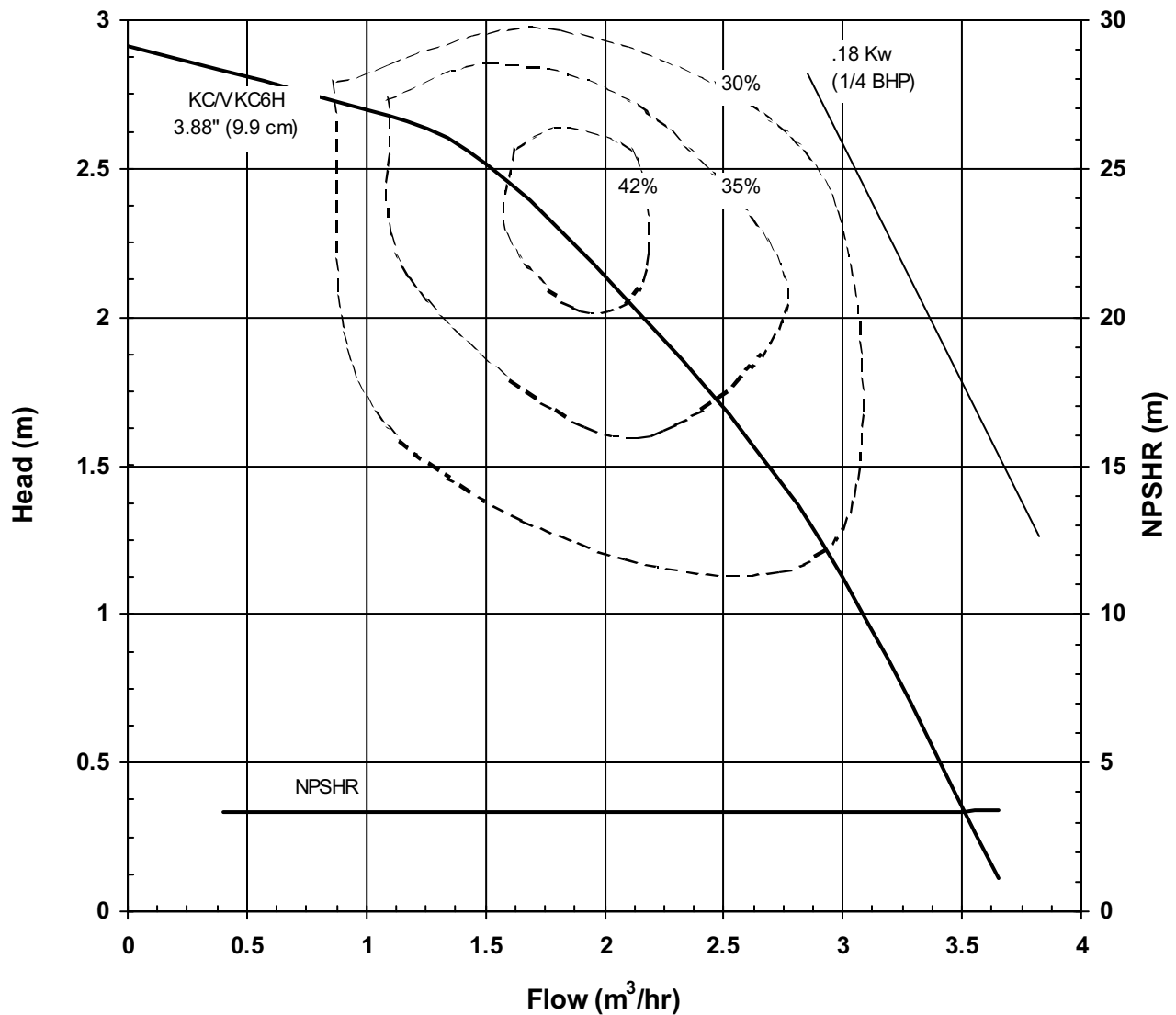

2034 REV 0  
5/11/01



KC/VKC SERIES  
STANDARD  
PERFORMANCE CURVE

MODEL KC7  
VKC7

3450 rpm, 60 Hz  
Suction: 1 1/2" FNPT  
Discharge: 1" MNPT

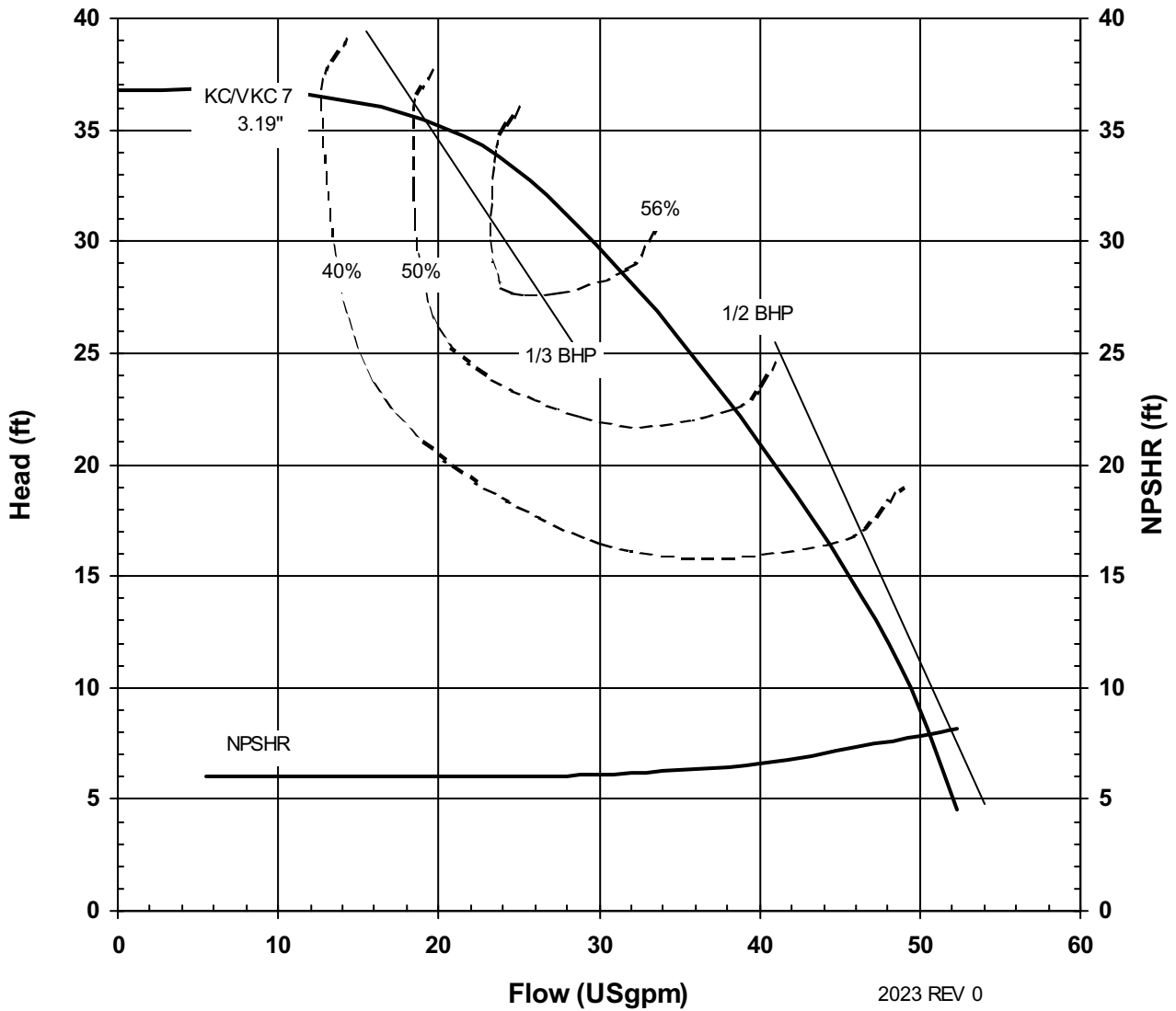

2023 REV 0  
4/11/01



KC/VKC SERIES  
STANDARD  
PERFORMANCE CURVE

MODEL KC7  
VKC7  
1725 rpm, 60 Hz  
Suction: 1 1/2" FNPT  
Discharge: 1" MNPT

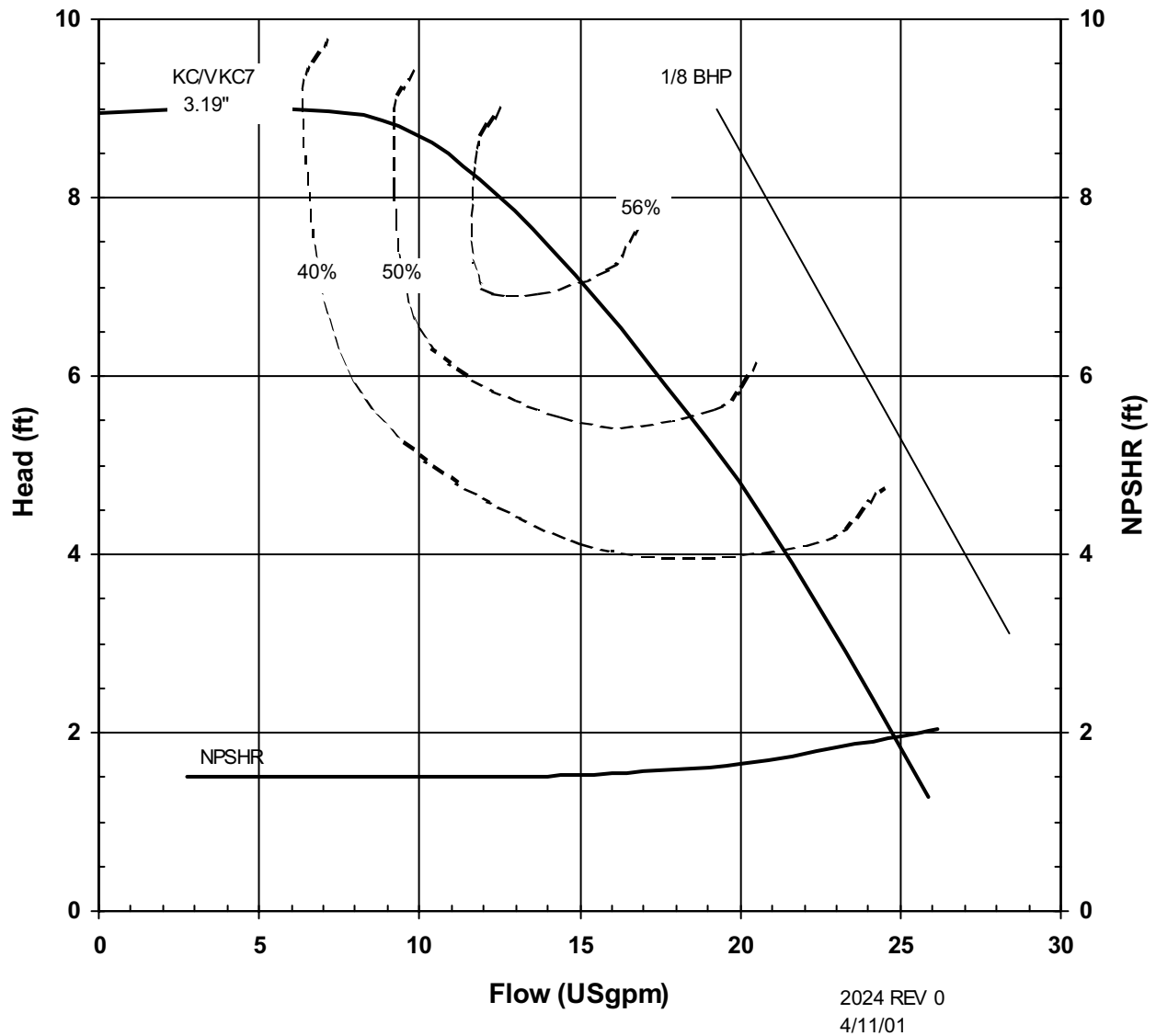



KC/VKC SERIES  
STANDARD  
PERFORMANCE CURVE

MODEL KC7  
VKC7  
2900 rpm, 50 Hz  
Suction: 1 1/2" FNPT  
Discharge: 1" MNPT

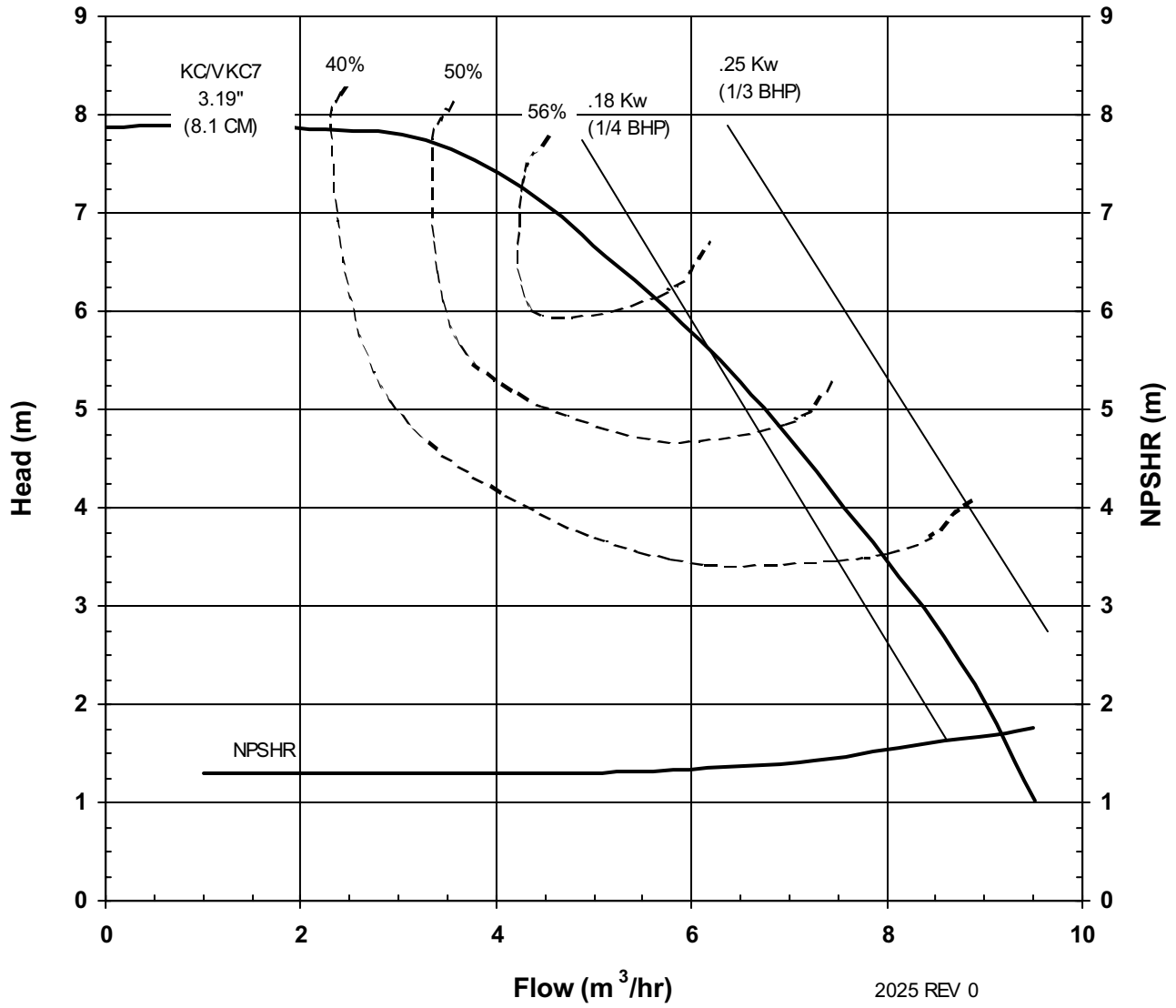

2025 REV 0  
4/11/01



KC/VKC SERIES  
STANDARD  
PERFORMANCE CURVE

MODEL KC7  
VKC7  
1450 rpm, 50 Hz  
Suction: 1 1/2" FNPT  
Discharge: 1" MNPT

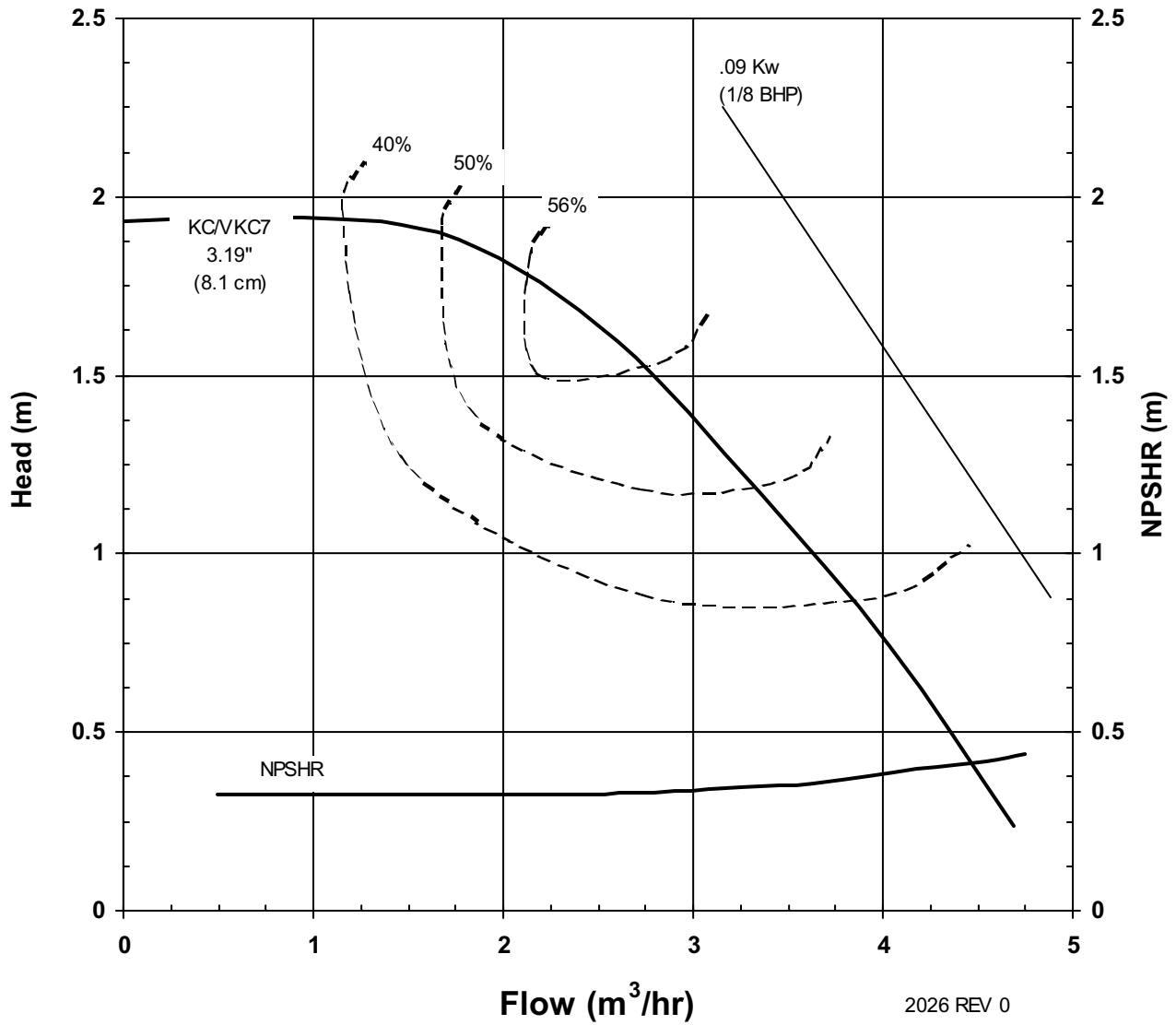

2026 REV 0  
4/11/01



KC/VKC SERIES  
STANDARD  
PERFORMANCE CURVE

MODEL KC8/10  
VKC8/10  
3450 rpm, 60 Hz  
Suction: 1 1/2" FNPT  
Discharge: 1" MNPT

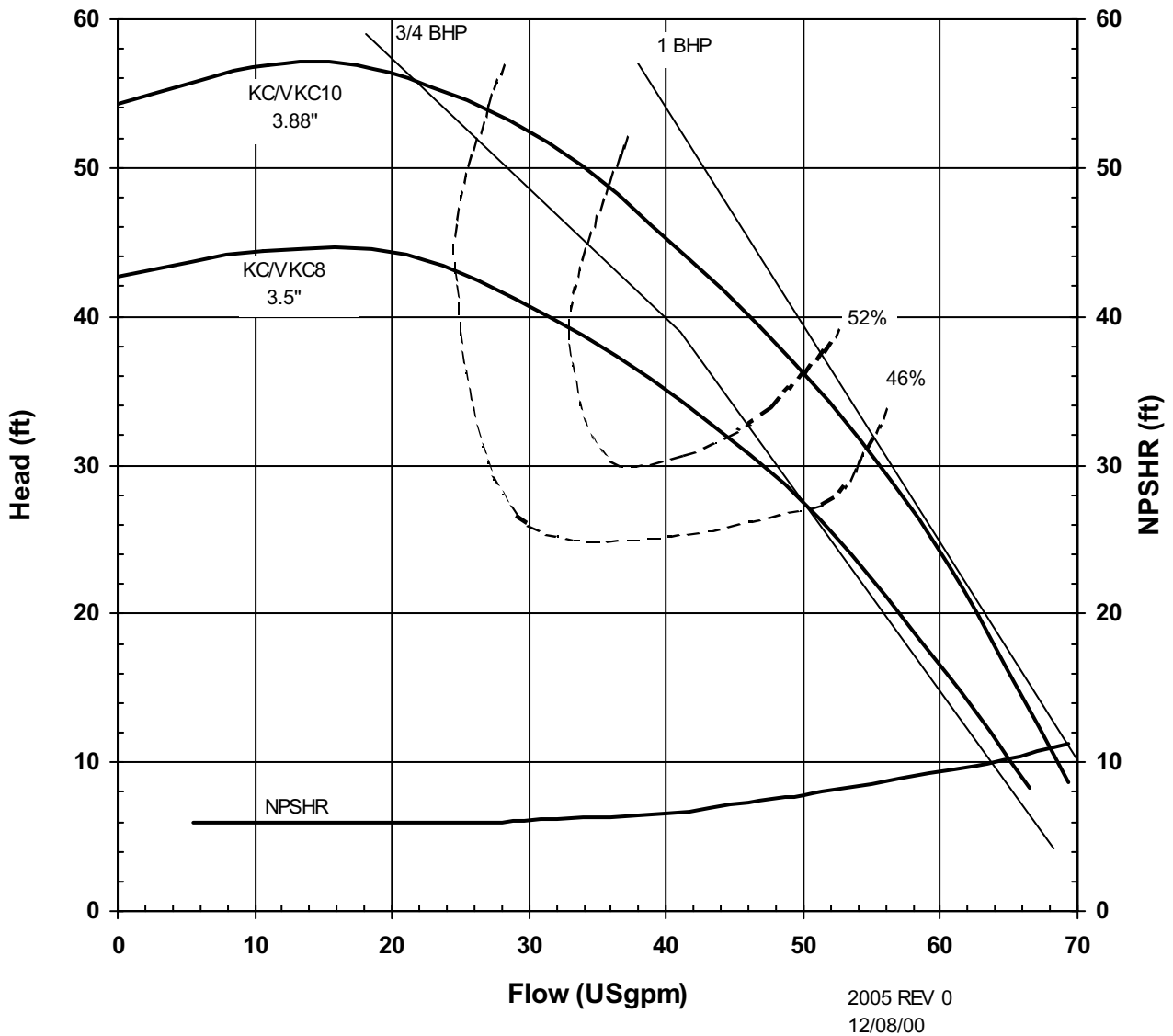



KC/VKC SERIES  
STANDARD  
PERFORMANCE CURVE

MODEL KC8/10  
VKC8/10

1725 rpm, 60 Hz  
Suction: 1 1/2" FNPT  
Discharge: 1" MNPT

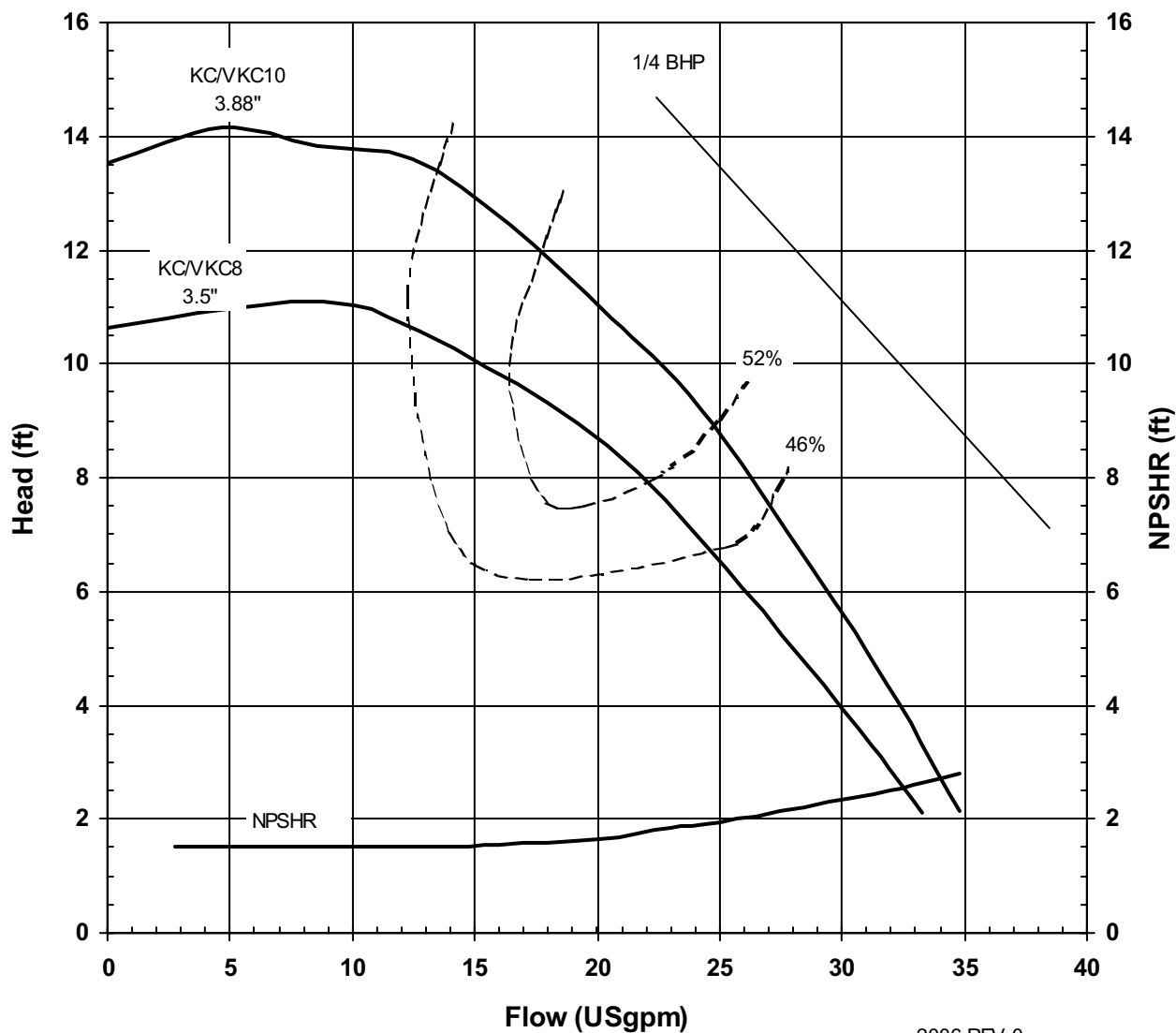

2006 REV 0  
12-08-00



KC/VKC SERIES  
STANDARD  
PERFORMANCE CURVE

MODEL KC8/10  
VKC8/10

2900 rpm, 50 Hz  
Suction: 1 1/2" FNPT  
Discharge: 1" MNPT

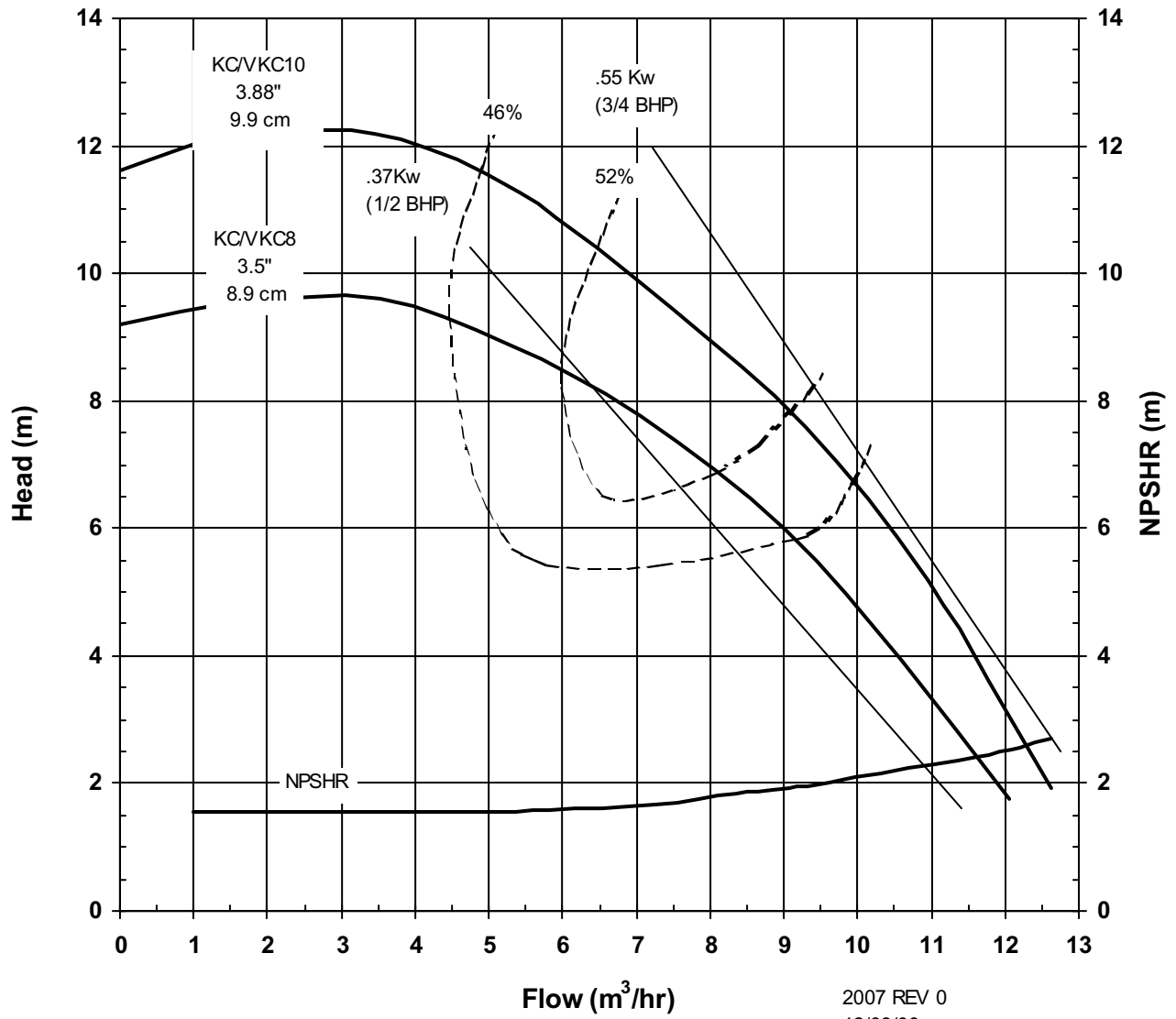

2007 REV 0  
12/08/00



KC/VKC SERIES  
STANDARD  
PERFORMANCE CURVE

MODEL KC8/10  
VKC8/10  
1450 rpm, 50 Hz  
Suction: 1 1/2" FNPT  
Discharge: 1" MNPT

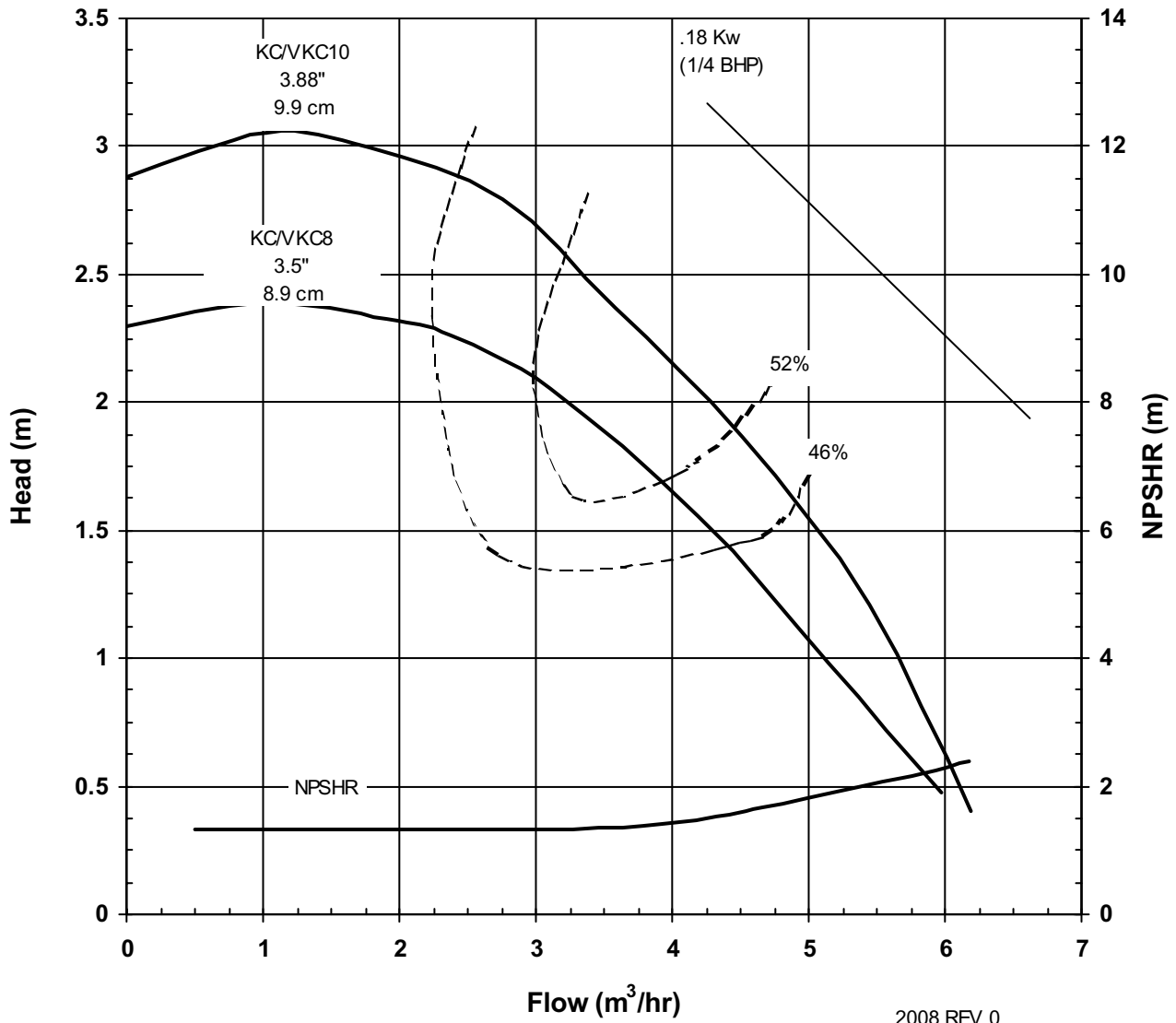

2008 REV 0  
12/08/00



KC/VKC SERIES  
STANDARD  
PERFORMANCE CURVE

MODEL KC11  
VKC11

3450 rpm, 60 Hz  
Suction: 1 1/2" FNPT  
Discharge: 1 1/4" MNPT

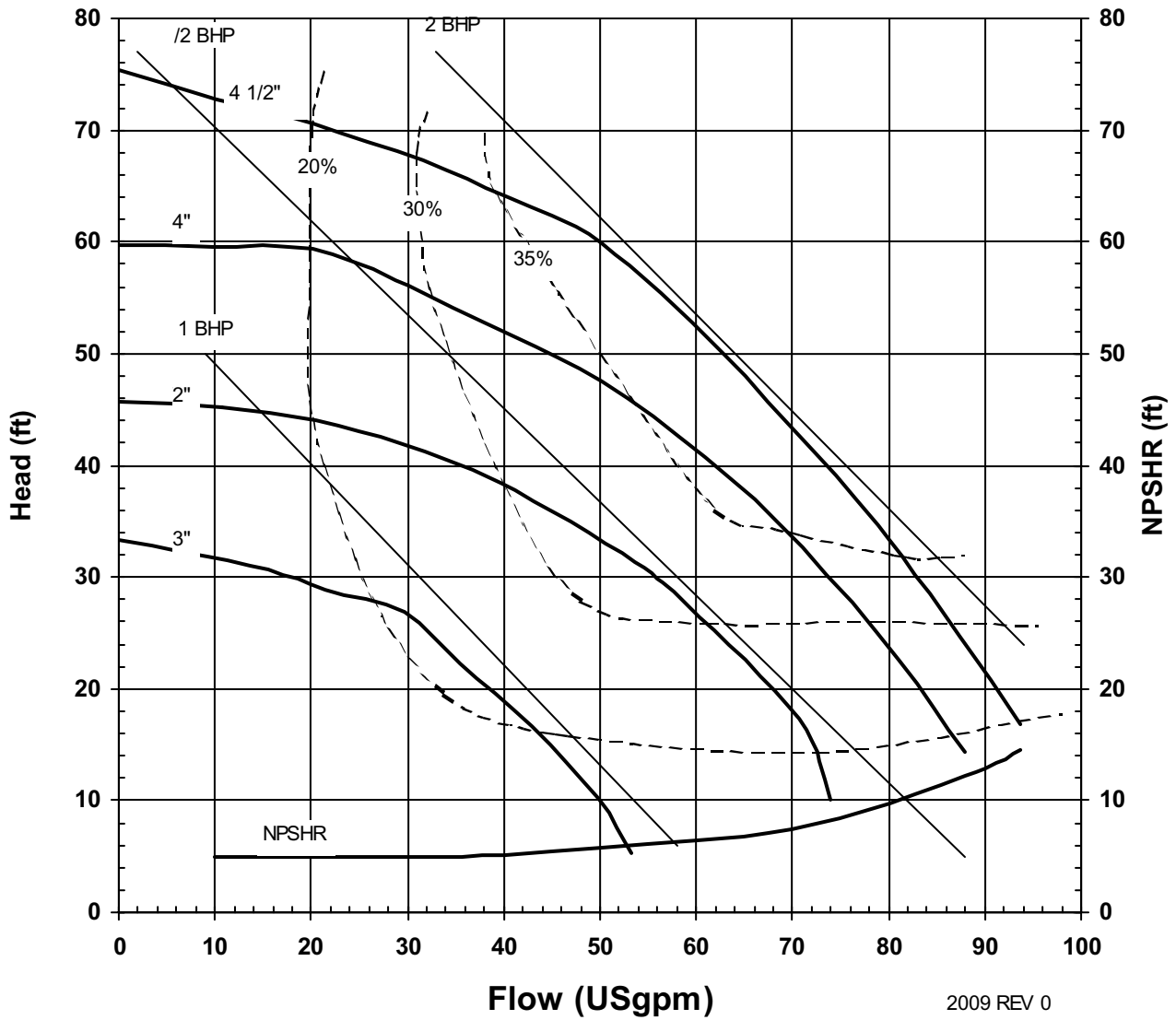

2009 REV 0  
12/08/00



KC/VKC SERIES  
STANDARD  
PERFORMANCE CURVE

MODEL KC11  
VKC11

1725 rpm, 60 Hz  
Suction: 1 1/2" FNPT  
Discharge: 1 1/4" MNPT

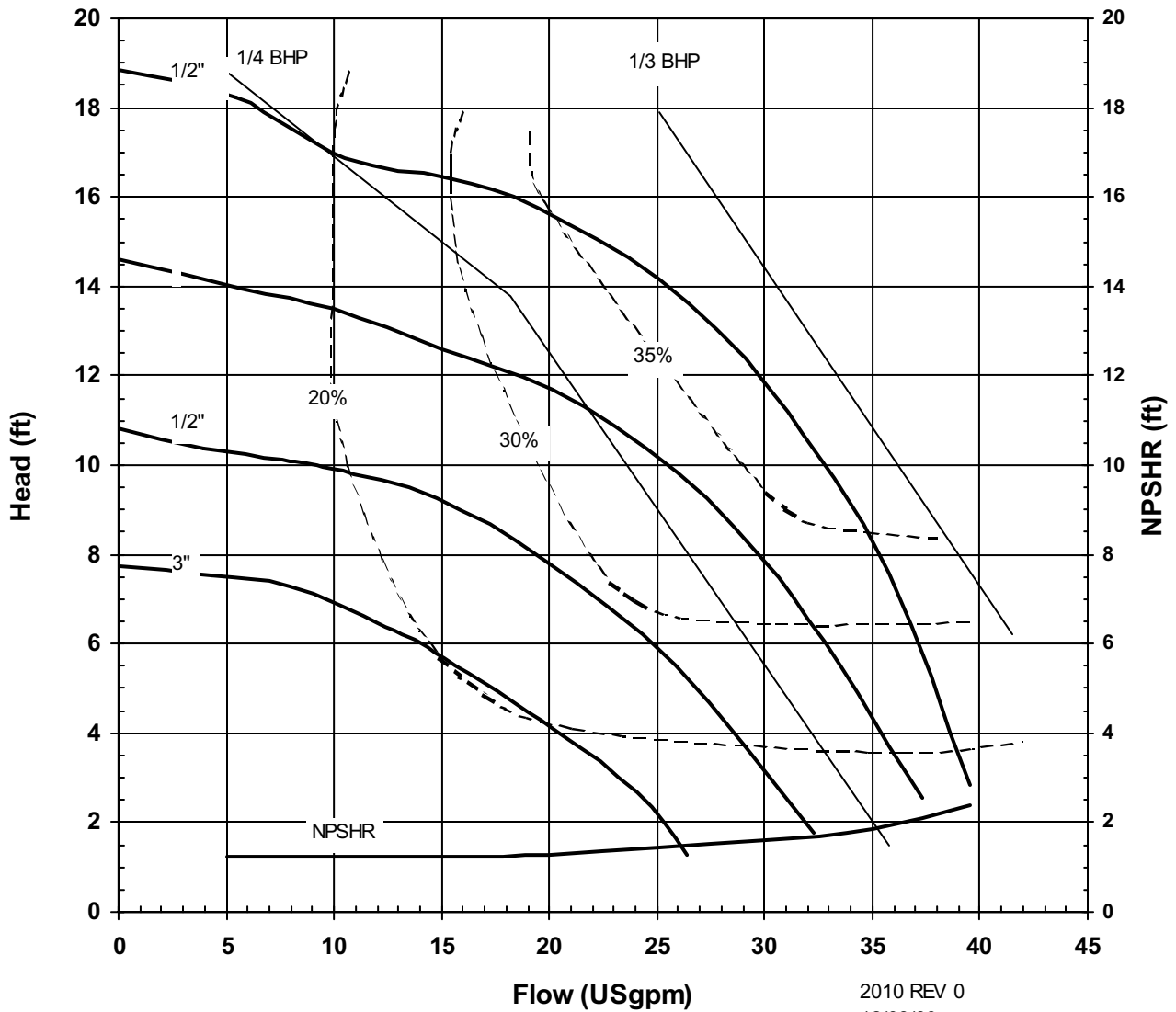

2010 REV 0  
12/08/00



KC/VKC SERIES  
STANDARD  
PERFORMANCE CURVE

MODEL KC11  
VKC11

2900 rpm, 50 Hz  
Suction: 1 1/2" FNPT  
Discharge: 1 1/4" MNPT

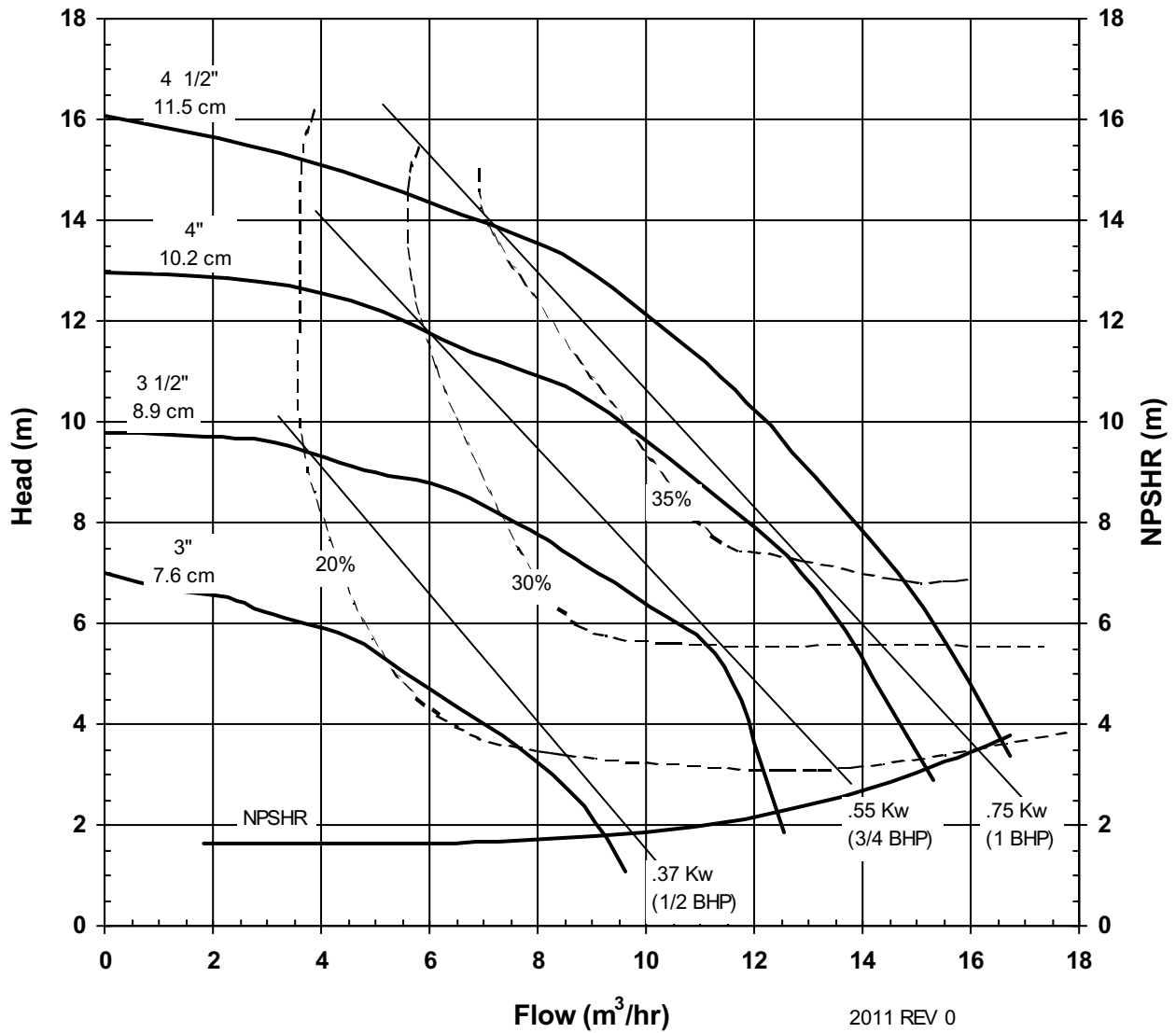



KC/VKC SERIES  
STANDARD  
PERFORMANCE CURVE

MODEL KC11  
VKC11  
1450 rpm, 50 Hz  
Suction: 1 1/2" FNPT  
Discharge: 1 1/4" MNPT

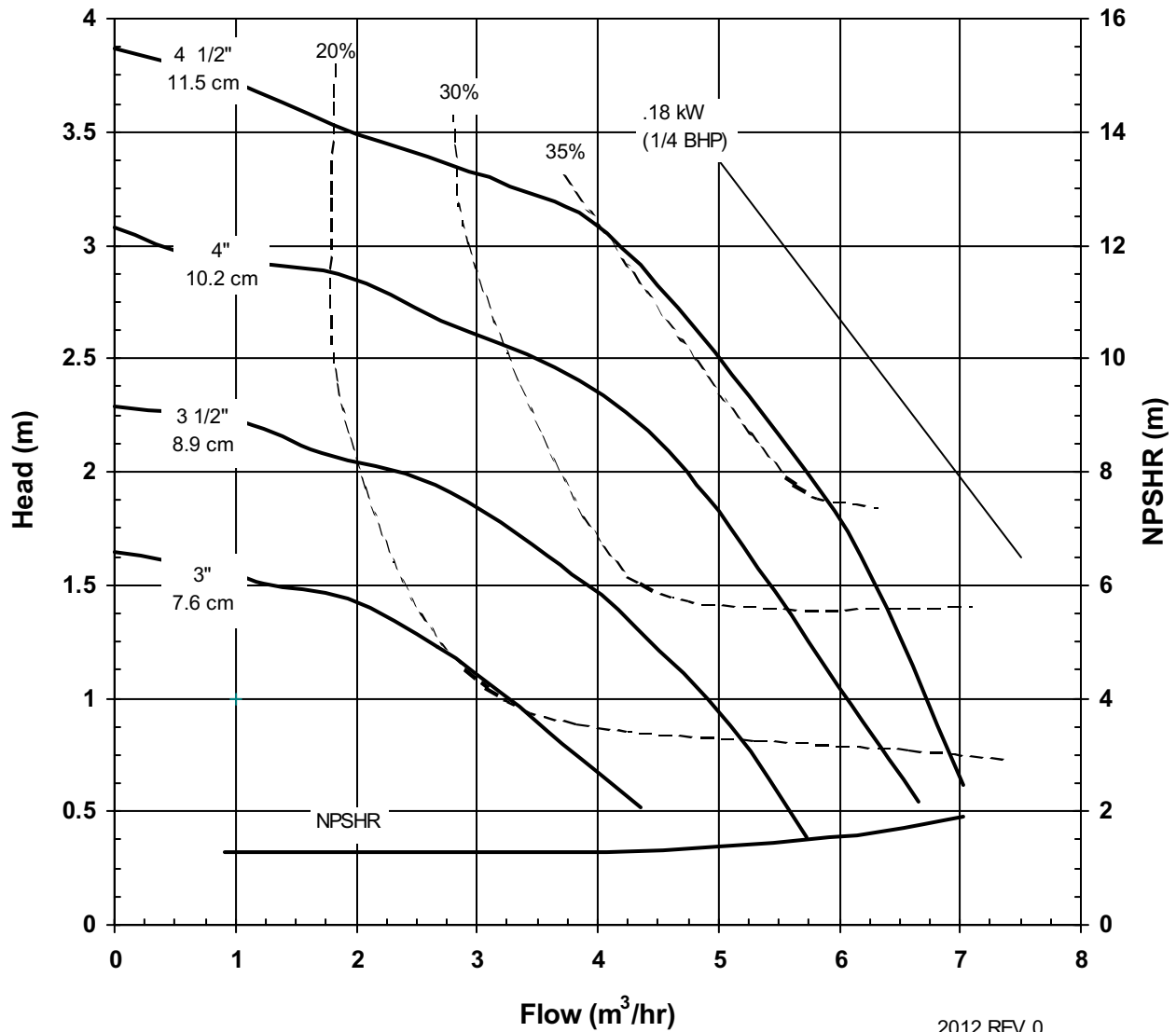

2012 REV 0  
12/08/00



KC/VKC SERIES  
MODEL KC/VKC 22/32  
PERFORMANCE CURVE

MODEL KC22/32  
VKC22

3450 rpm, 60 Hz  
Suction: 2" FNPT/3" FLANGE  
Discharge: 2" MNPT/2" FLANGE  
OPEN IMPELLER

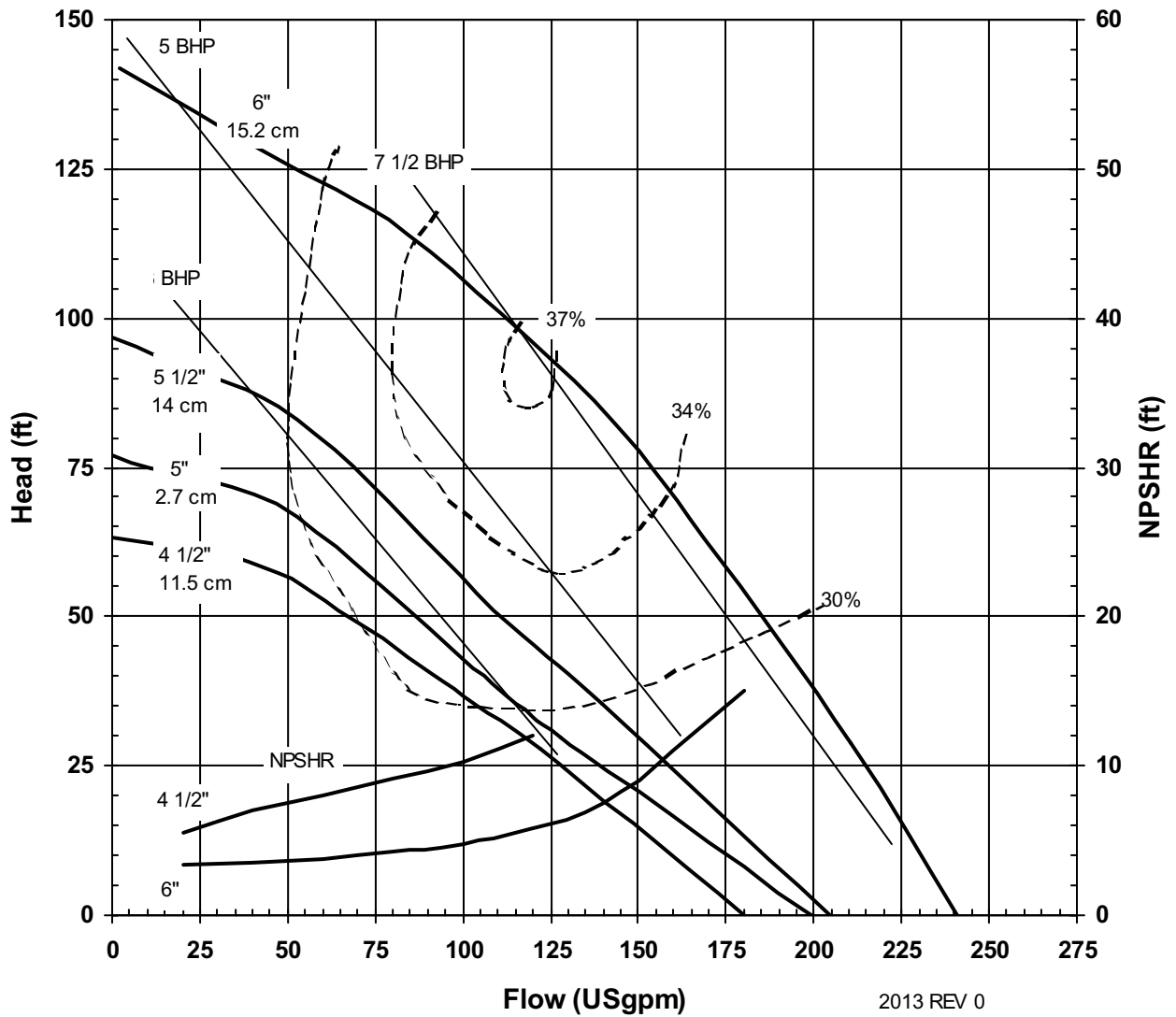

2013 REV 0  
12/08/00



KC/KC SERIES  
STANDARD  
PERFORMANCE CURVE

MODEL KC22/32  
VKC22

1725 rpm, 60 Hz  
Suction: 2" FNPT/3" FLANGE  
Discharge: 2" MNPT/2" FLANGE  
OPEN IMPELLER

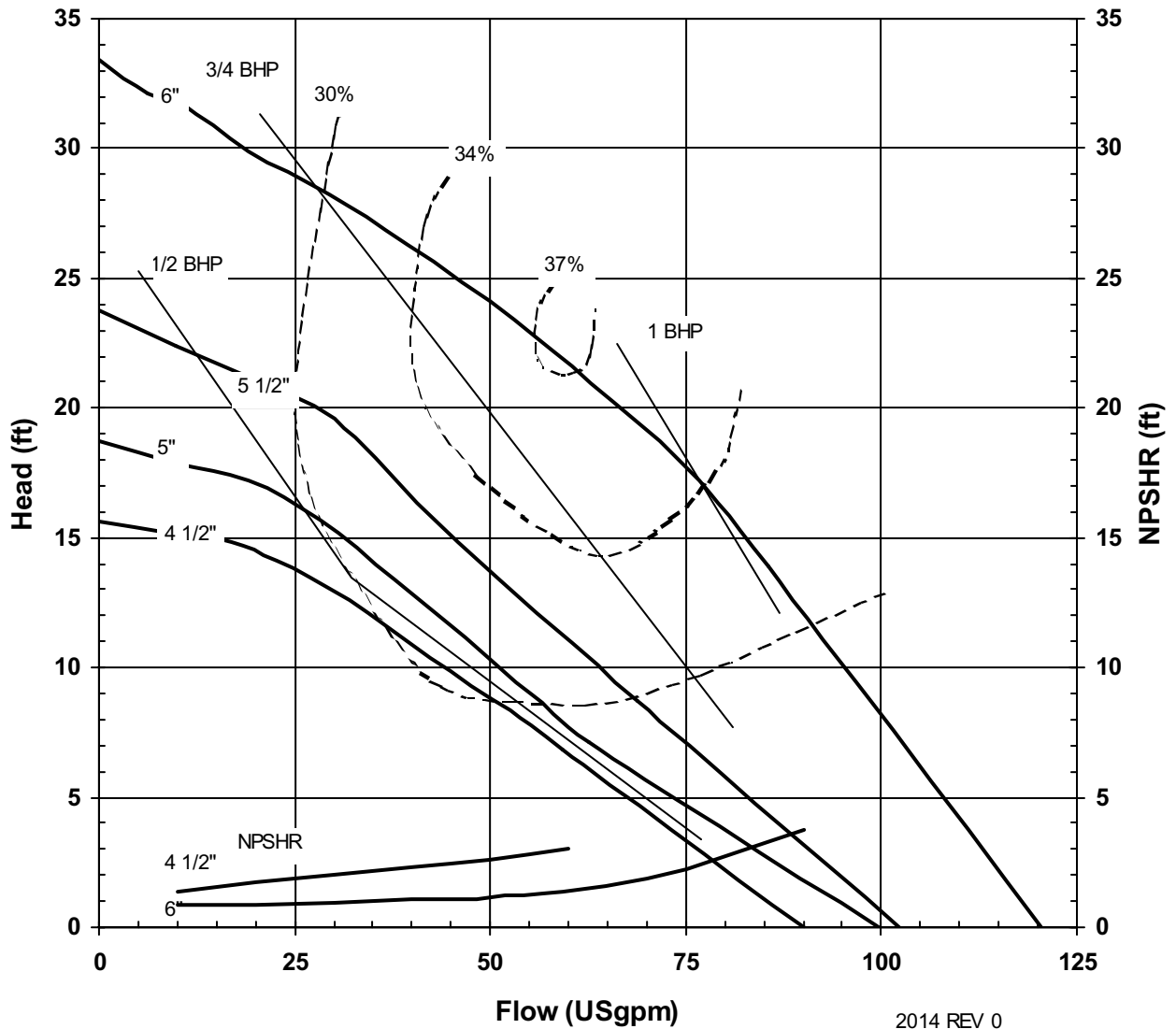

2014 REV 0  
12/08/00



KC/KC SERIES  
STANDARD  
PERFORMANCE CURVE

MODEL KC22/32  
VKC22

2900 rpm, 50 Hz  
Suction: 2" FNPT/3" FLANGE  
Discharge: 2" MNPT/2" FLANGE  
OPEN IMPELLER

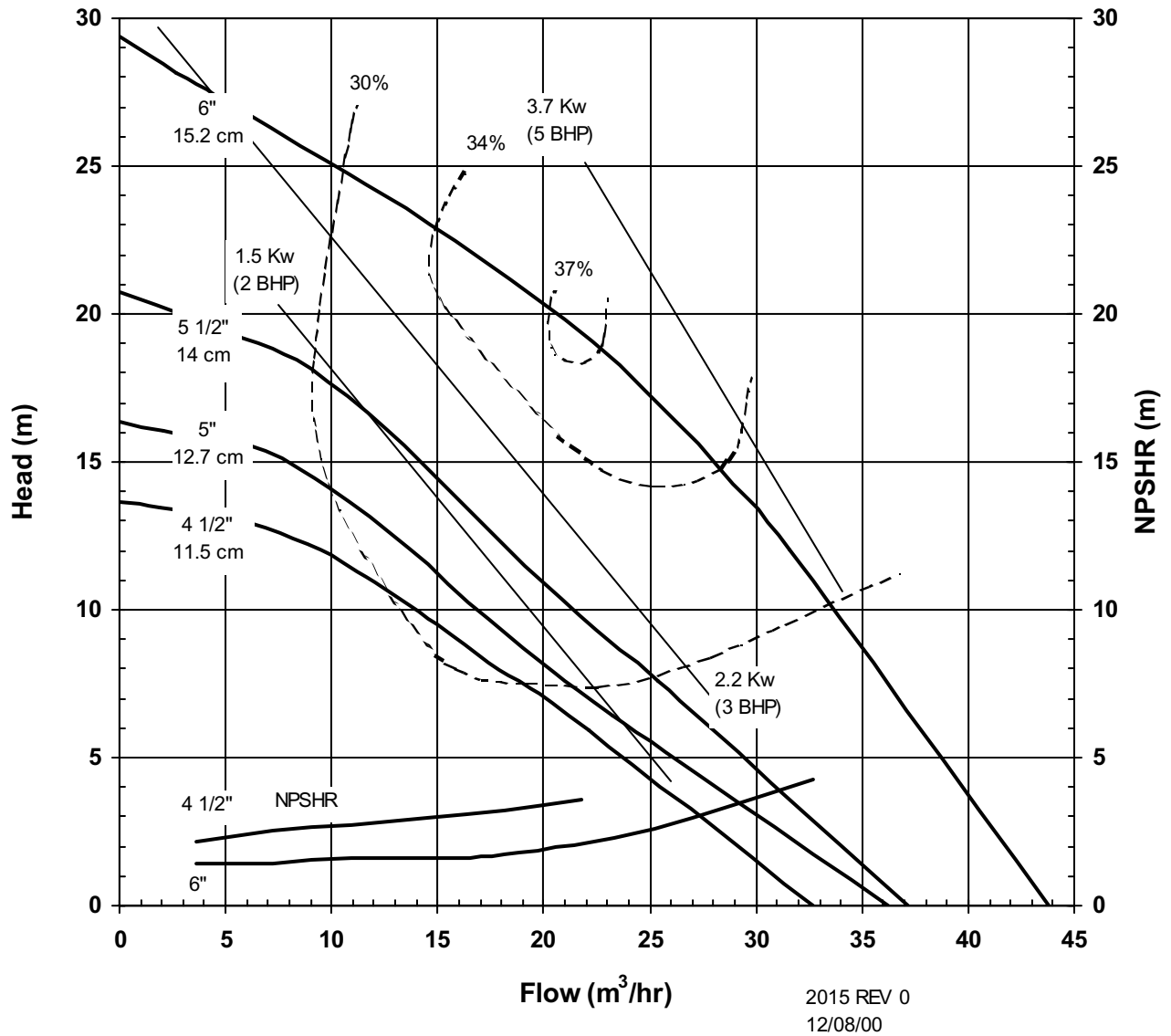



KC/KC SERIES  
STANDARD  
PERFORMANCE CURVE

MODEL KC22/32  
VKC22

1450 rpm, 50 Hz  
Suction: 2" FNPT/3" FLANGE  
Discharge: 2" MNPT/2" FLANGE  
OPEN IMPELLER

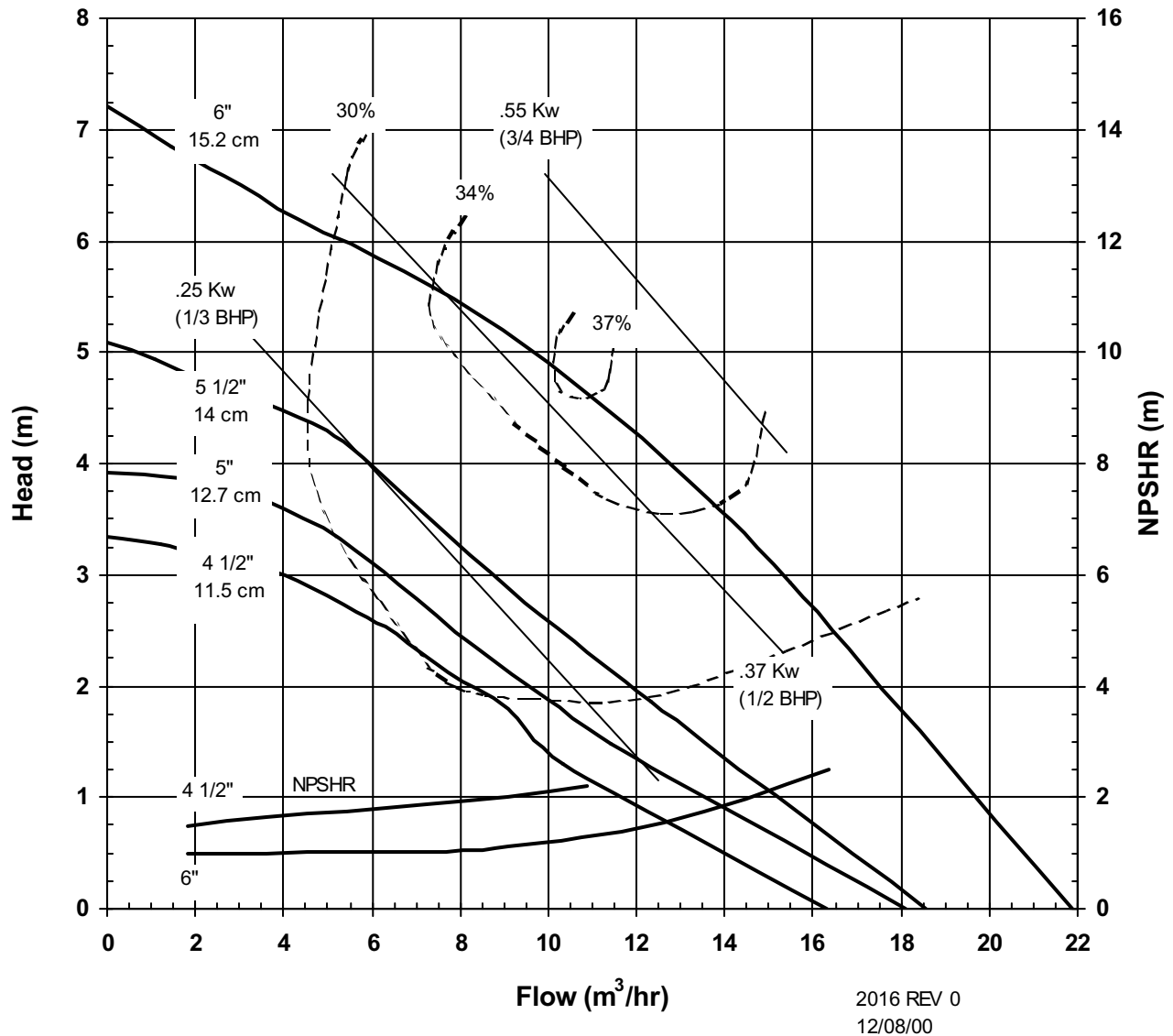



KC/VKC SERIES  
STANDARD  
PERFORMANCE CURVE

MODEL KC22/32  
VKC22

3450 rpm, 60 Hz

Suction: 2" FNPT/3" FLANGE

Discharge: 2" MNPT/2" FLANGE

CLOSED IMPELLER

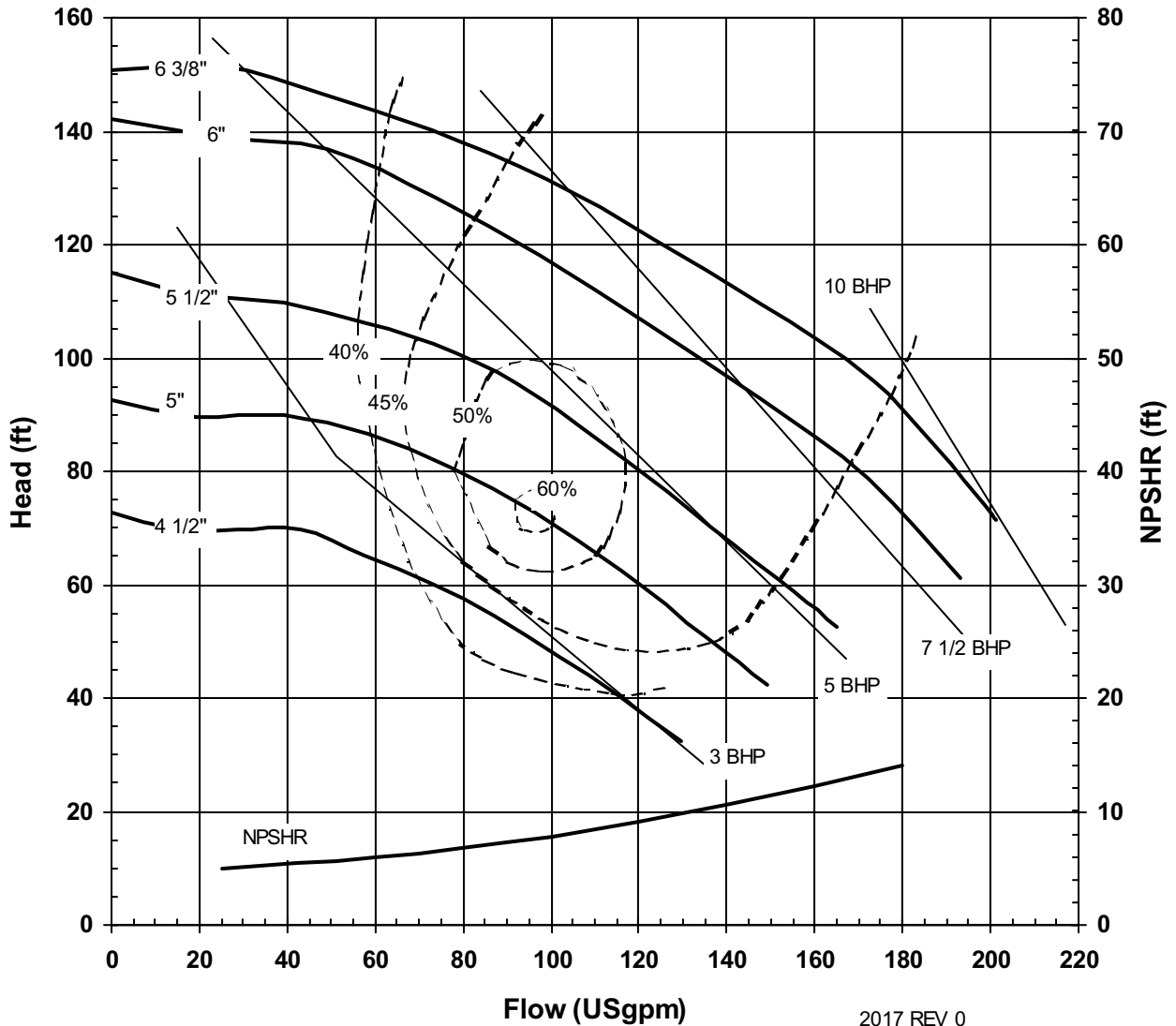

2017 REV 0  
12/08/00



KC/VKC SERIES  
STANDARD  
PERFORMANCE CURVE

MODEL KC22/32  
VKC22

1725 rpm, 60 Hz  
Suction: 2" FNPT/3" FLANGE  
Discharge: 2" MNPT/2" FLANGE  
CLOSED IMPELLER

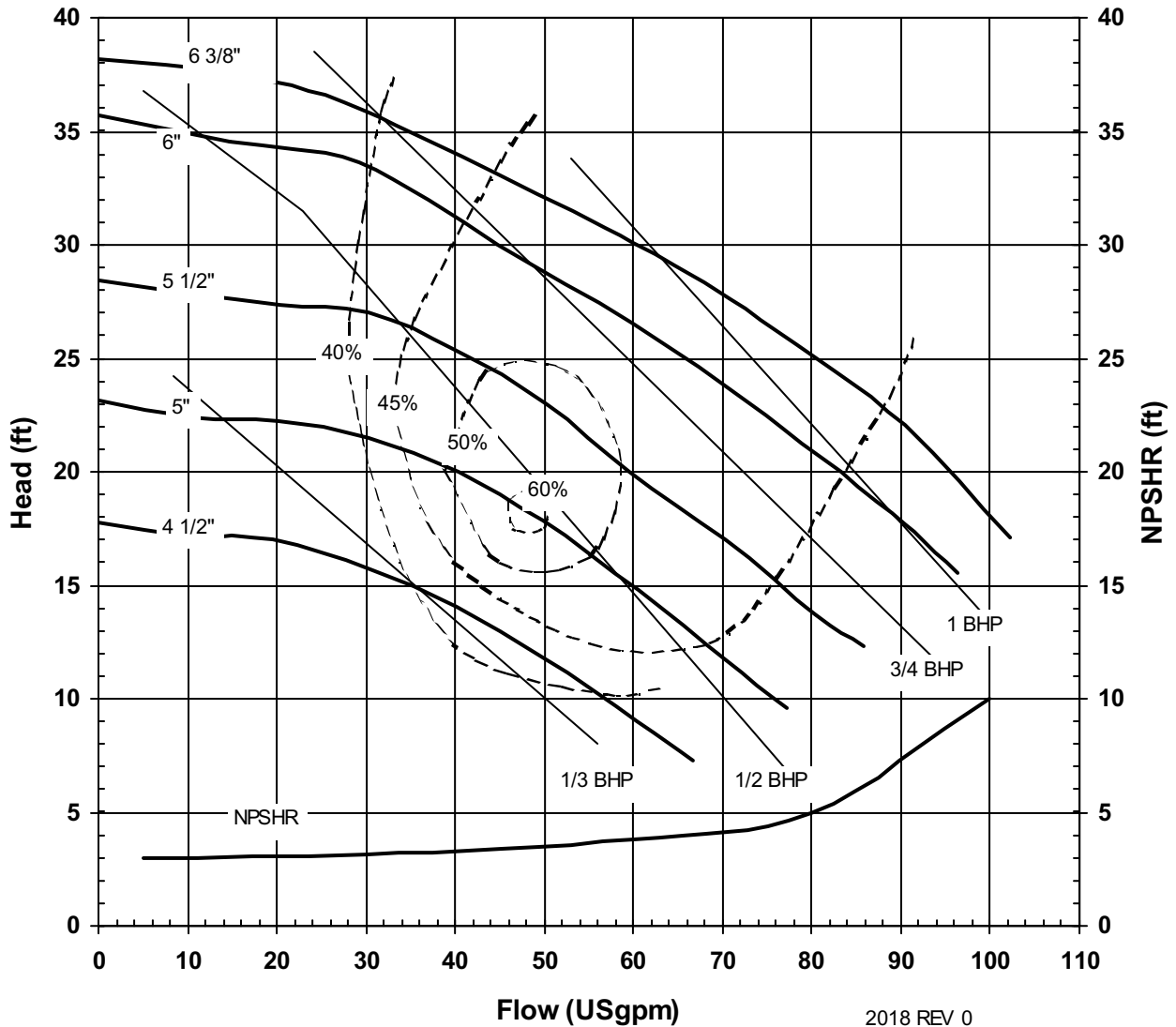

2018 REV 0  
12/28/00



KC/VKC SERIES  
STANDARD  
PERFORMANCE CURVE

MODEL KC22/32  
VKC22

2900 rpm, 50 Hz  
Suction: 2" FNPT/3" FLANGE  
Discharge: 2" MNPT/2" FLANGE  
CLOSED IMPELLER

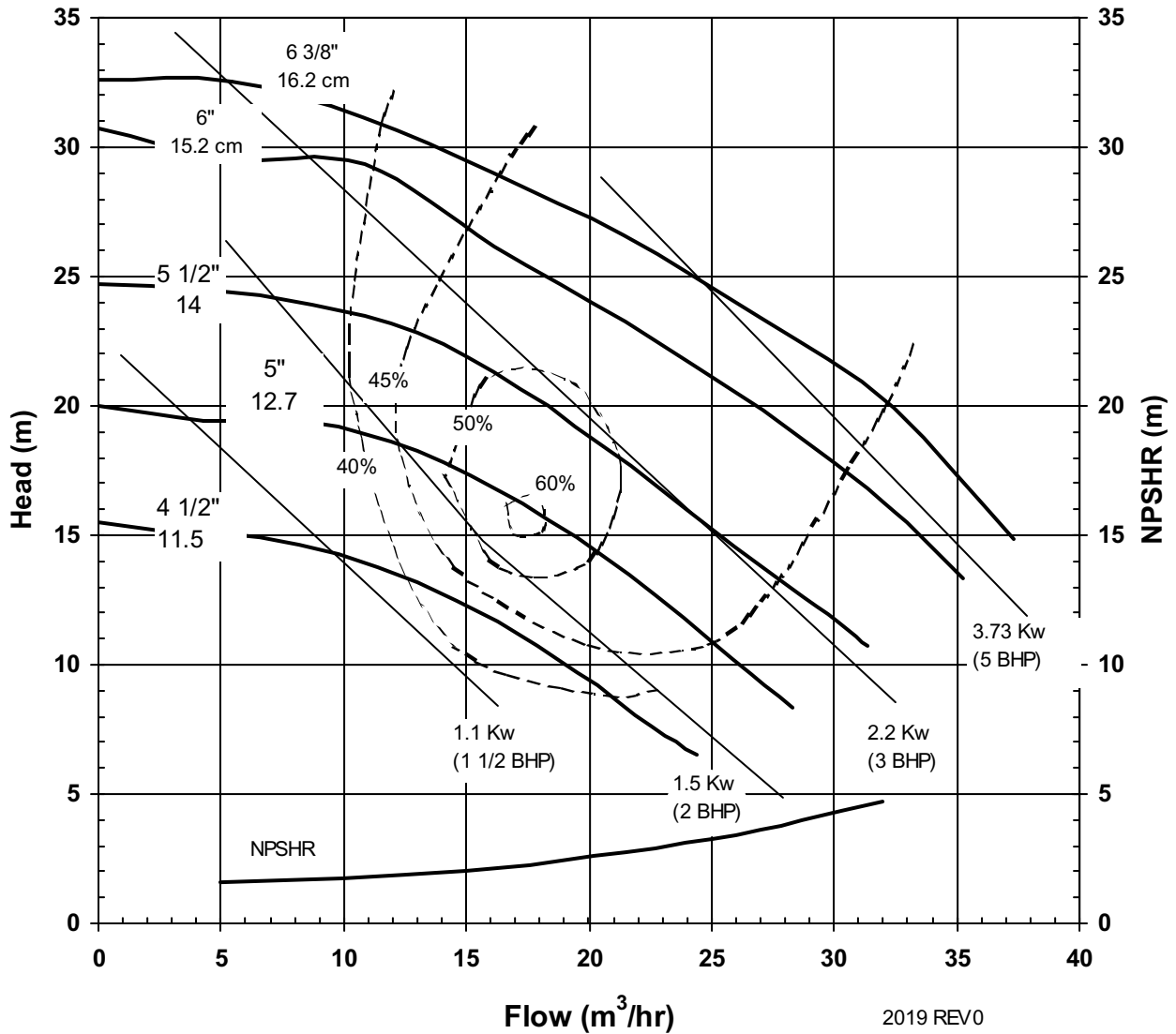

2019 REV0  
12/22/00



KC/KC SERIES  
STANDARD  
PERFORMANCE CURVE

MODEL KC22/32  
VKC22

1450 rpm, 50 Hz  
Suction: 2" FNPT/3" FLANGE  
Discharge: 2" MNPT/2" FLANGE  
CLOSED IMPELLER

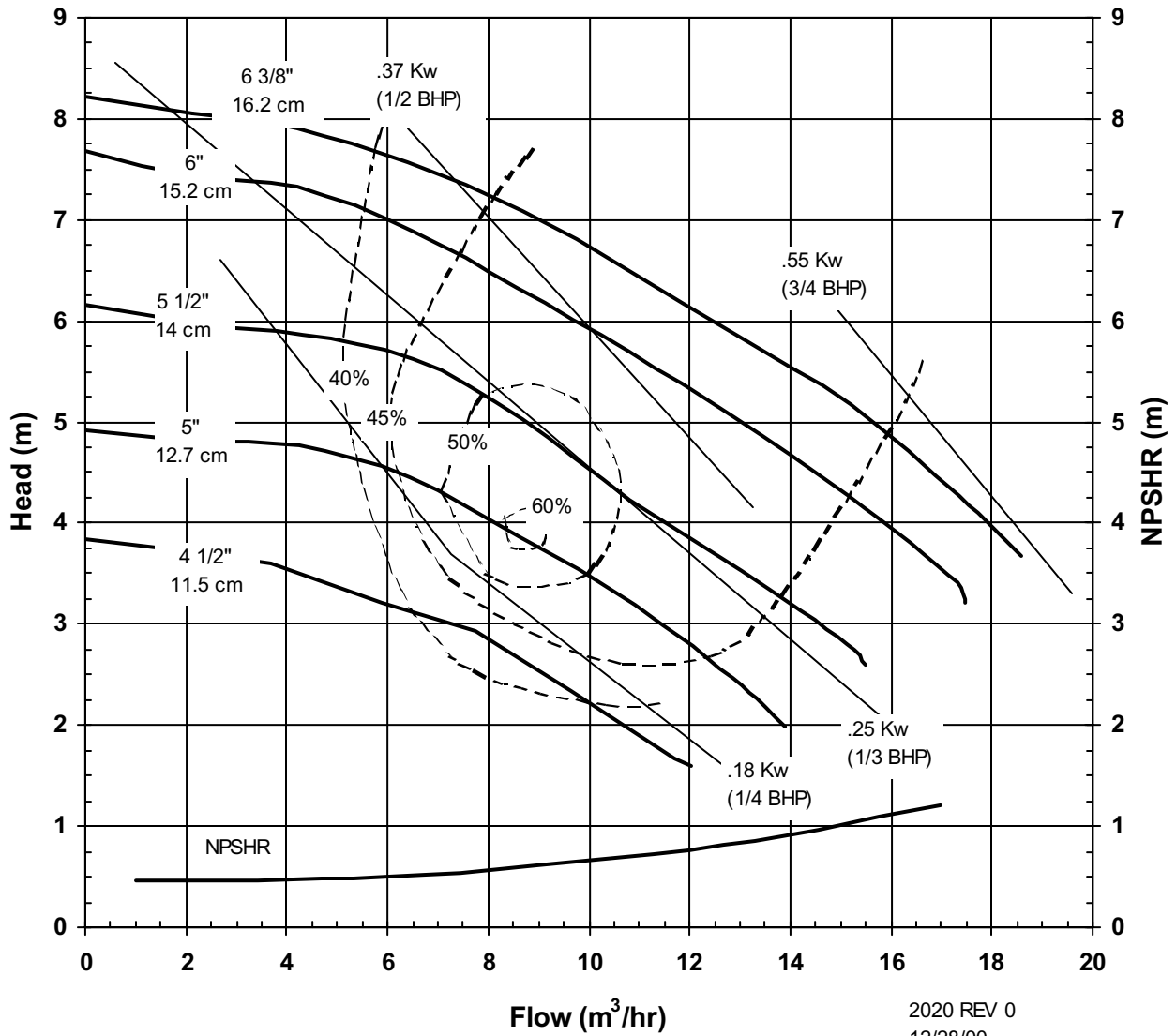



MULTISTAGE SERIES  
STANDARD  
PERFORMANCE CURVE

MODEL MSKC  
MSVKC  
MSVKCW  
3450 rpm, 60 Hz  
Suction: 1 1/2" FNPT  
Discharge: 1" MNPT

- 1. MSKC - 3.88"-3.88"
- 2. MSKC - 3.5"-3.88"
- 3. MSKC - 3.5"-3.5"
- 4. MSKC - 3.19"-3.5"
- 5. MSKC - 3.0"-3.5"

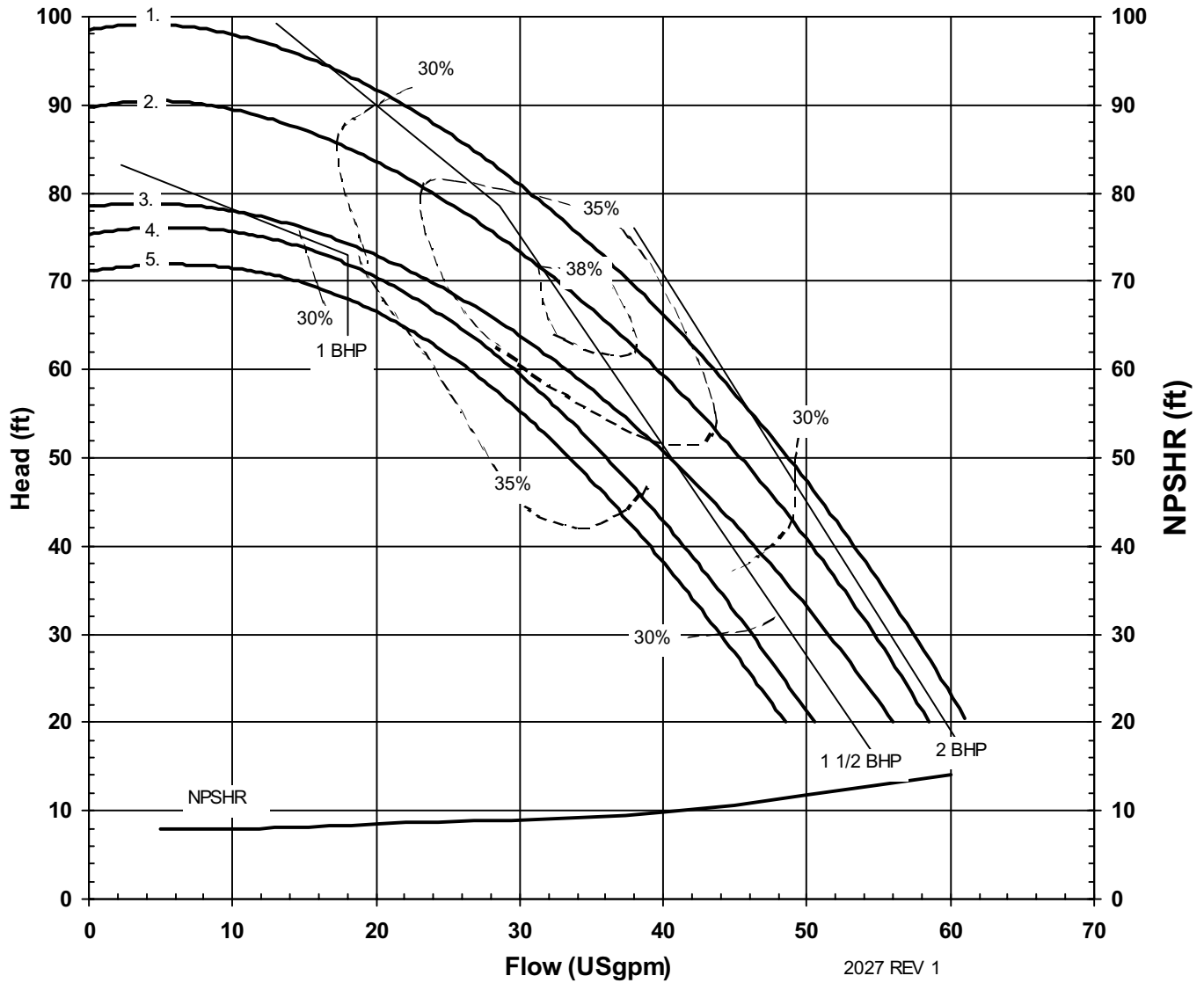

2027 REV 1  
12/17/01



MULTISTAGE SERIES  
STANDARD  
PERFORMANCE CURVE

MODEL MSKC

MSVKC

MSVKCW

1725 rpm, 60 Hz

Suction: 1 1/2" FNPT

Discharge: 1" MNPT

- 1. MSKC - 3.88"-3.88"
- 2. MSKC - 3.5"-3.88"
- 3. MSKC - 3.5"-3.5"
- 4. MSKC - 3.19"-3.5"
- 5. MSKC - 3.0"-3.5"

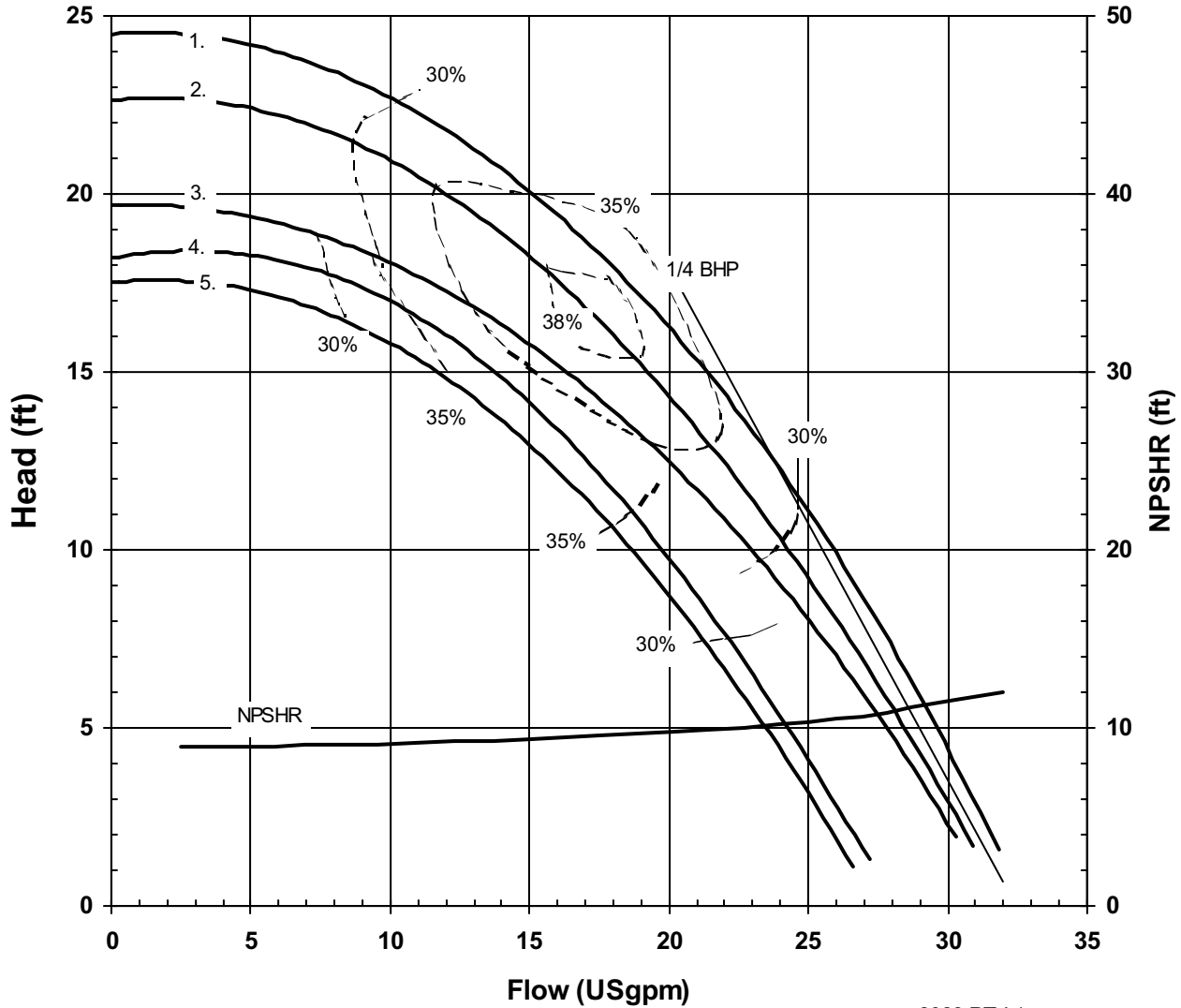

2028 REV 1  
12/17/01



# MULTISTAGE SERIES STANDARD PERFORMANCE CURVE

**MODEL MSKC  
MSVKC  
MSVKCW**

**2900 rpm, 50 Hz  
Suction: 1 1/2" FNPT  
Discharge: 1" MNPT**

- 1. MSKC - 9.86cm-9.86cm
- 2. MSKC - 8.89cm-9.86cm
- 3. MSKC - 8.89cm-8.89cm
- 4. MSKC - 8.10cm-8.89cm
- 5. MSKC - 7.62cm-8.89cm

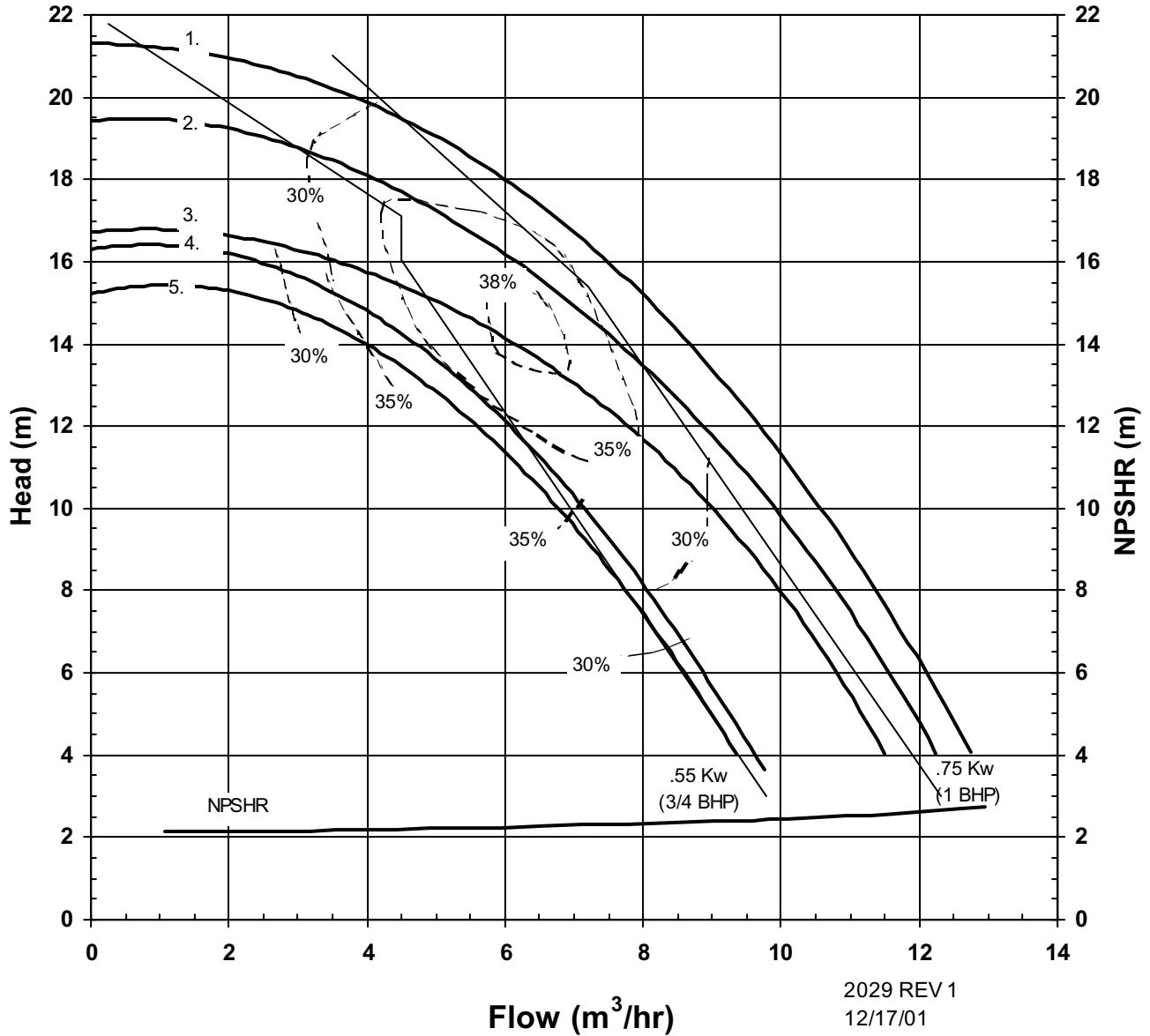

2029 REV 1  
12/17/01



MULTISTAGE SERIES  
STANDARD  
PERFORMANCE CURVE

MODEL MSKC

MSVKC

MSVKCW

1450 rpm, 50 Hz

Suction: 1 1/2" FNPT

Discharge: 1" MNPT

- 1. MSKC - 9.86cm-9.86cm
- 2. MSKC - 8.89cm-9.86cm
- 3. MSKC - 8.89cm-8.89cm
- 4. MSKC - 8.10cm-8.89cm
- 5. MSKC - 7.62cm-8.89cm

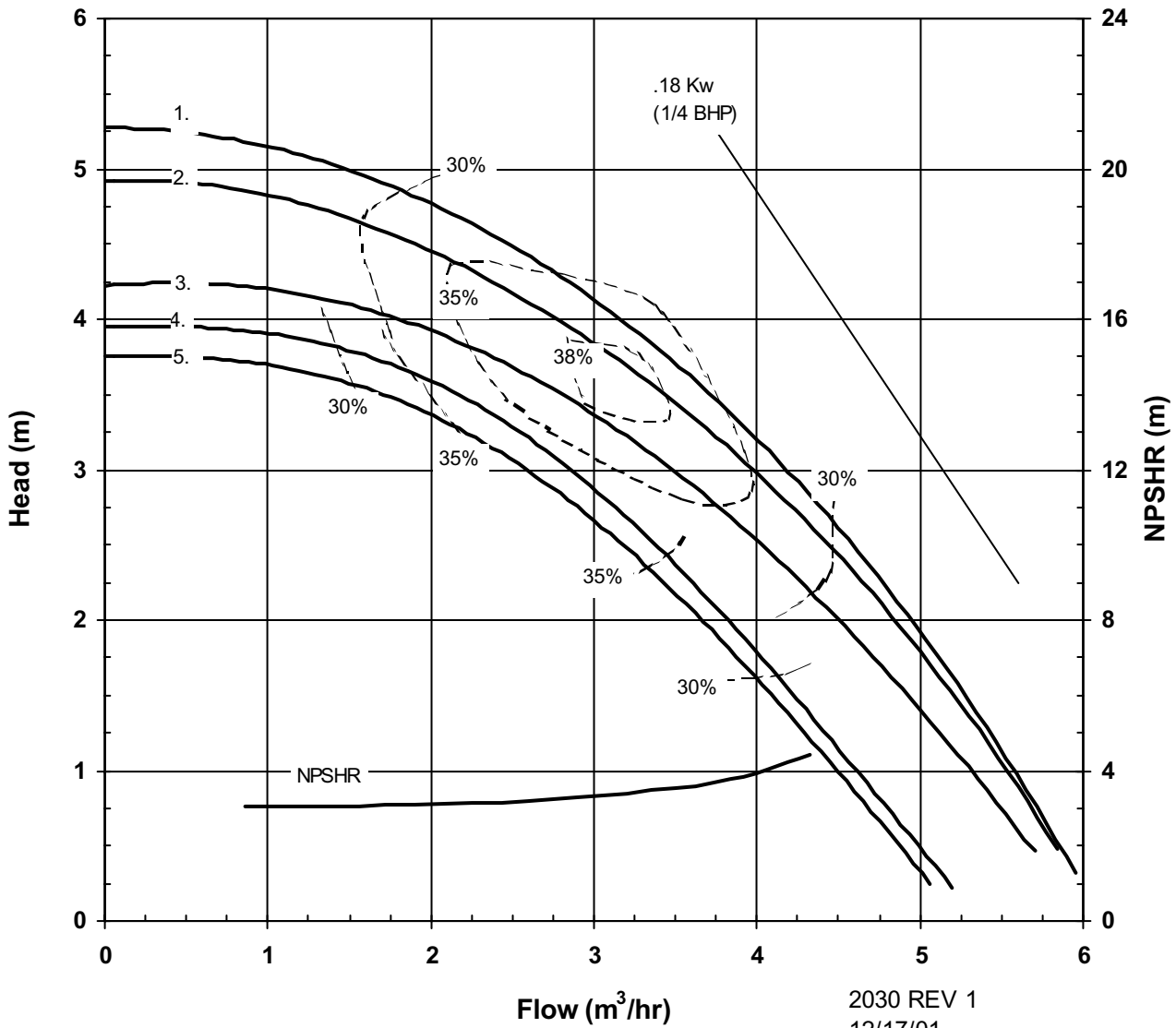

2030 REV 1  
12/17/01



KC11 MAGPRIME  
STANDARD  
PERFORMANCE CURVE

MODEL KC11 MAGPRIME  
3450 rpm, 60 Hz

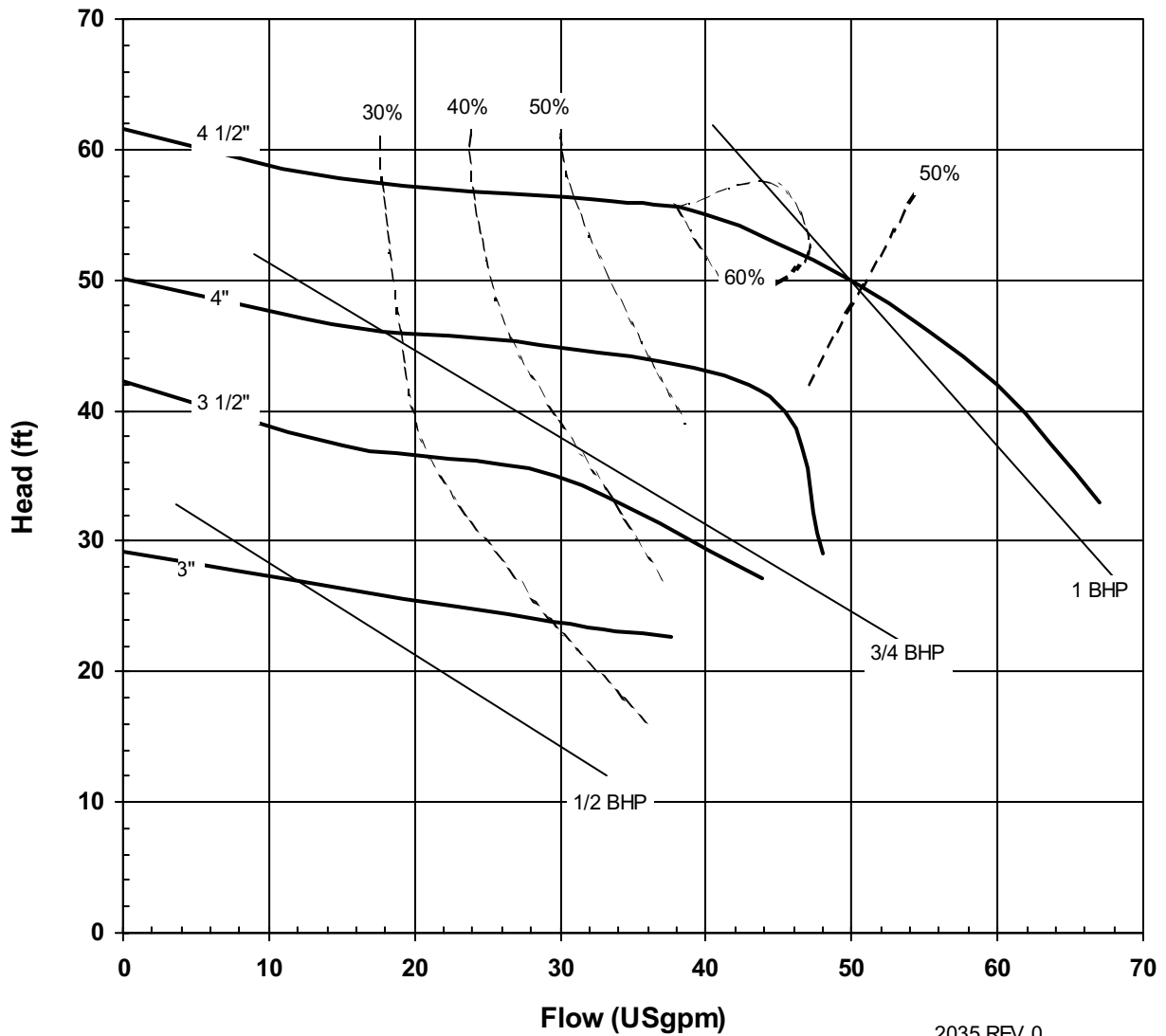

2035 REV 0  
7/18/02



# KC11 MAGPRIME STANDARD PERFORMANCE CURVE

## MODEL KC11 MAGPRIME

1725 rpm, 60 Hz

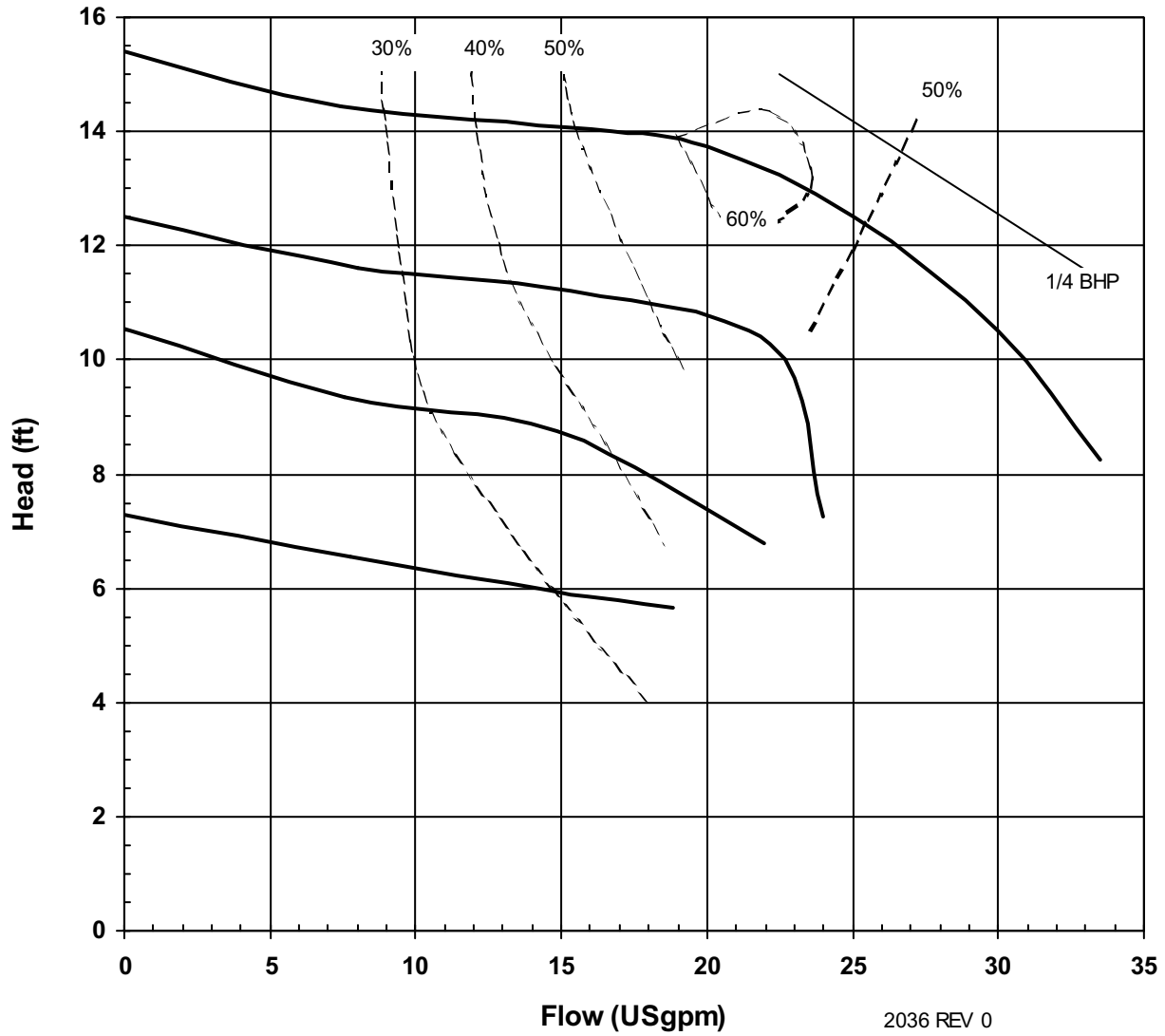

2036 REV 0  
7/18/02



KC11 MAGPRIME  
STANDARD  
PERFORMANCE CURVE

MODEL KC11 MAGPRIME

2900 rpm, 50 Hz

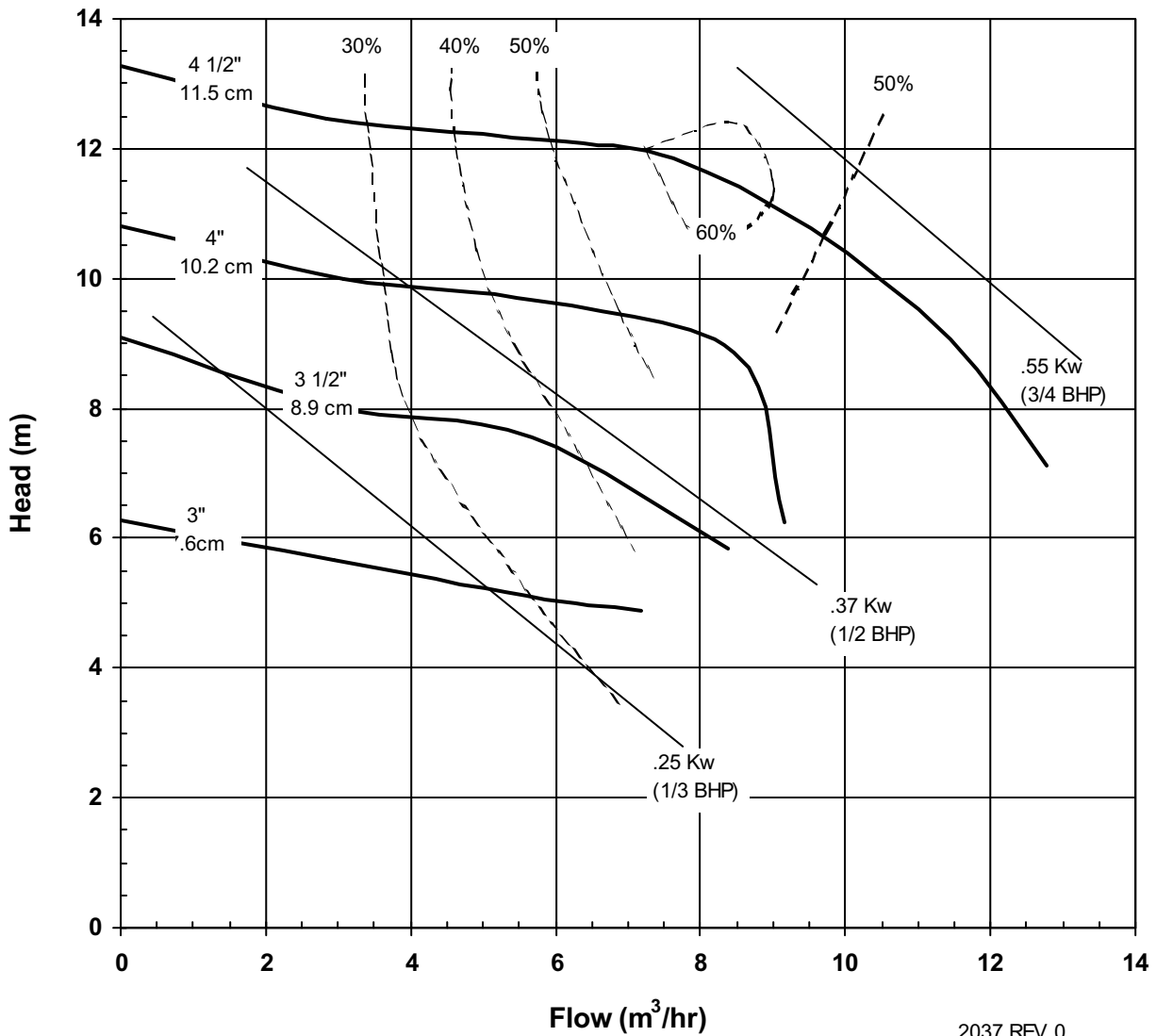

2037 REV 0  
7/18/02



KC11 MAGPRIME  
STANDARD  
PRIMING TIME/LIFT CURVE

MODEL KC11 MAGPRIME  
3450 rpm, 60 Hz

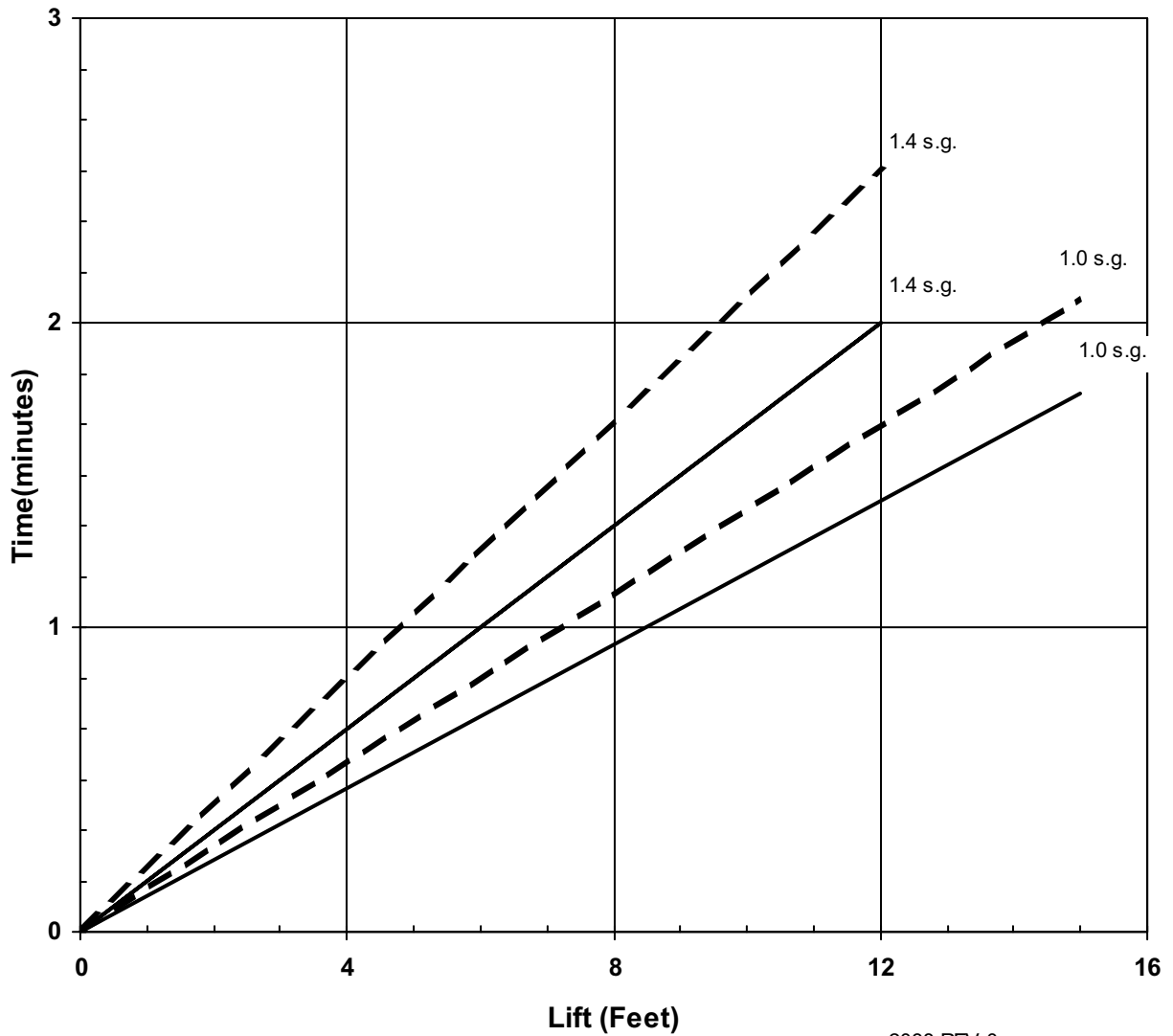
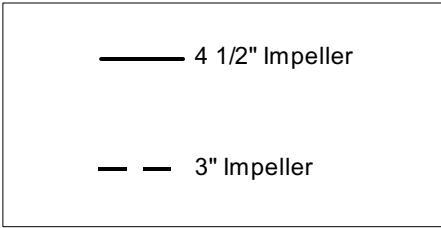

2038 REV 0  
07/18/02



**KC11 MAGPRIME  
STANDARD  
PRIMING TIME/LIFT CURVE**

**MODEL KC11 MAGPRIME  
1725 rpm, 60 Hz**

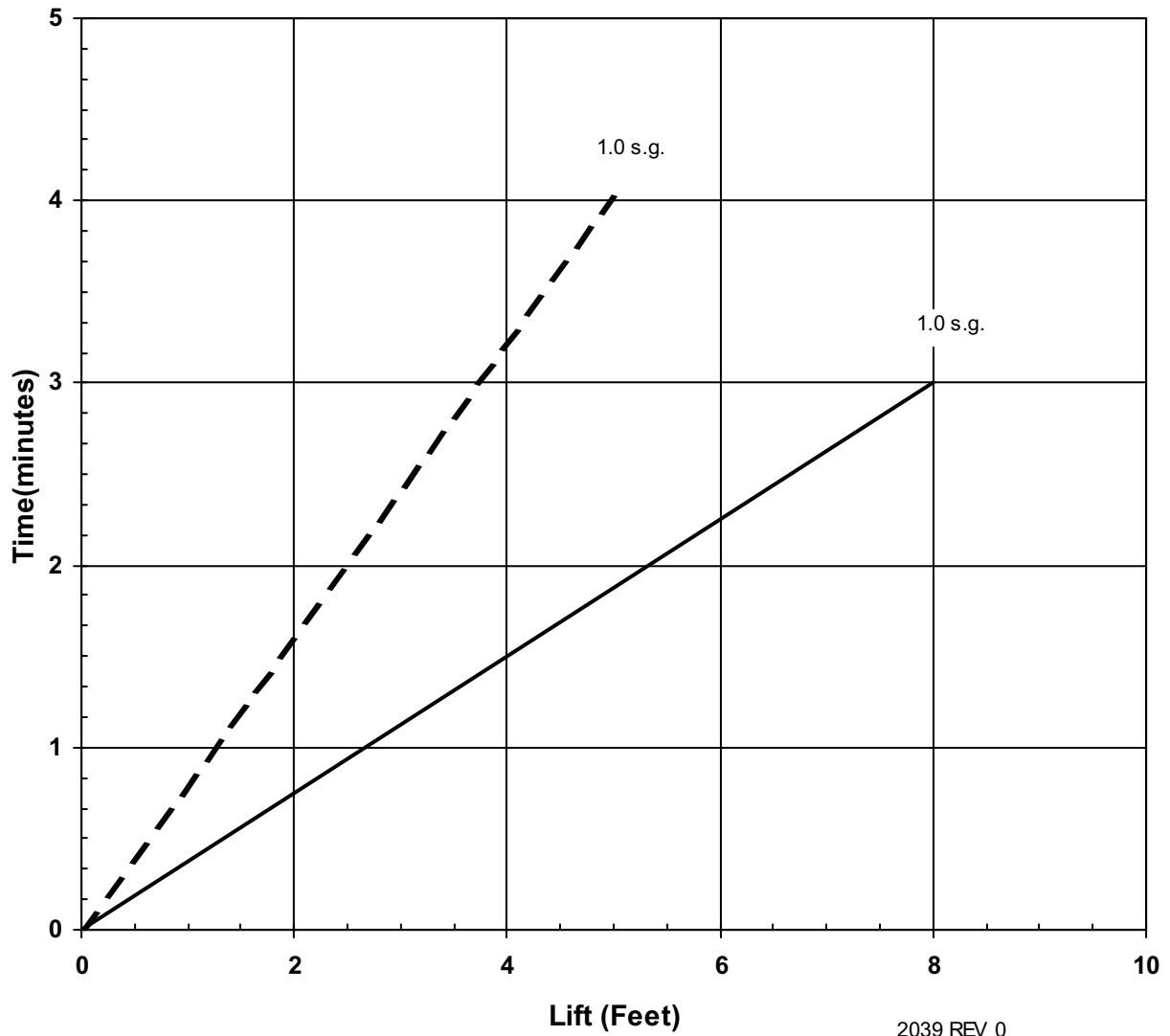
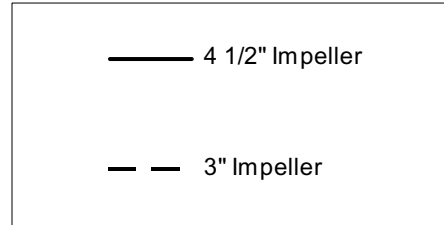

2039 REV 0  
07/18/02



**KC11 MAGPRIME  
STANDARD  
PRIMING TIME/LIFT CURVE**

**MODEL KC11 MAGPRIME**

**2900 rpm, 50 Hz**

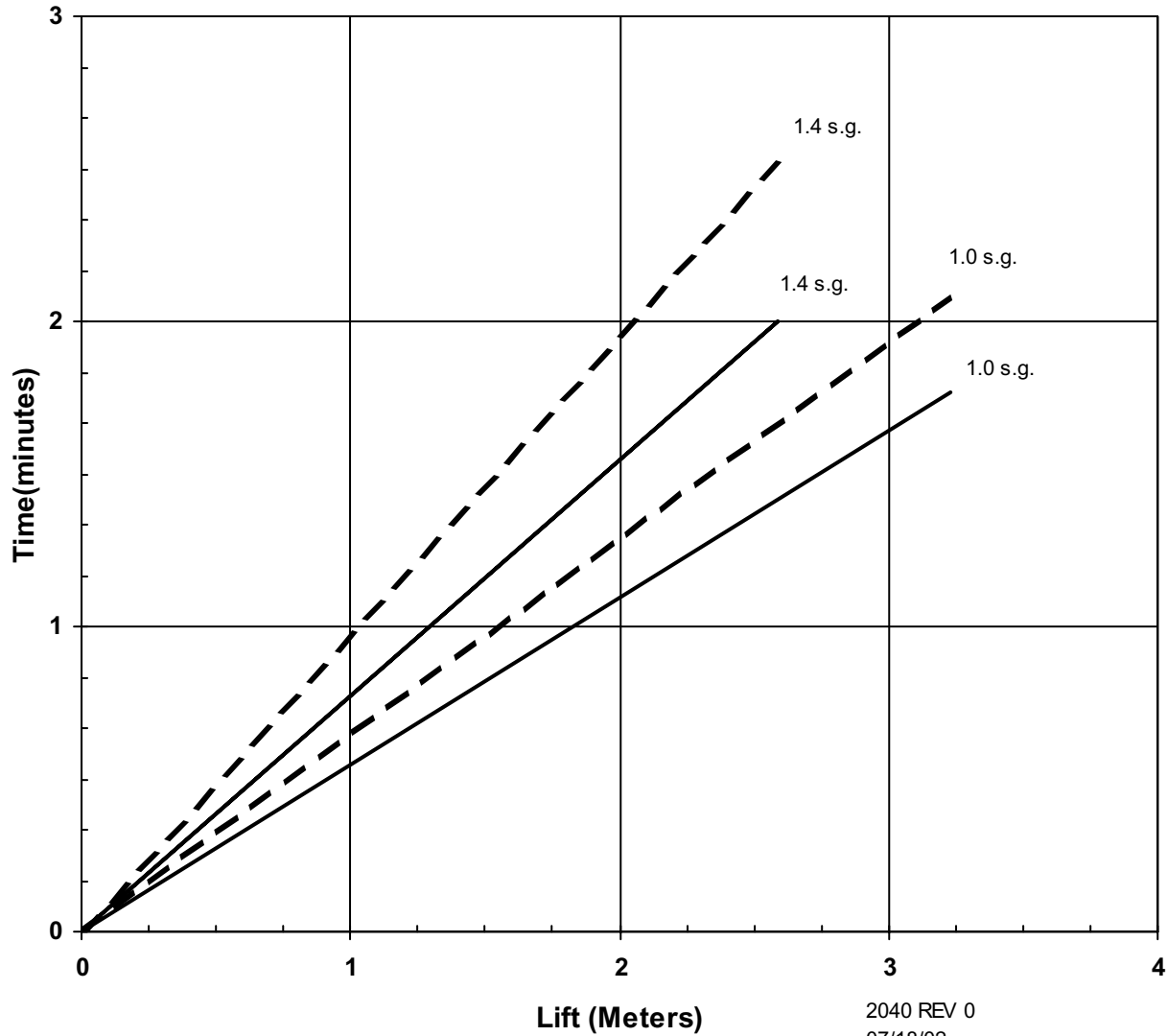
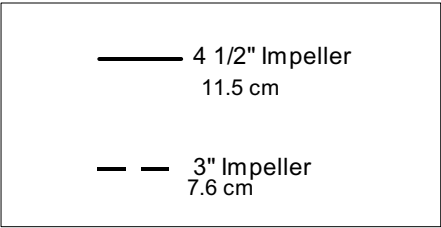

2040 REV 0  
07/18/02



---

**FINISH THOMPSON INC.**

921 Greengarden Road • Erie, PA 16507-1591 U.S.A.  
Ph 814-455-4478 • Fax 814-455-8518  
Email [fti@finishthompson.com](mailto:fti@finishthompson.com) • [www.finishthompson.com](http://www.finishthompson.com)