

Dimensions

With NEMA TEFC Motors (Inches)

MODEL	MOTOR FRAME	A12-60	B	C*	D*
VKC22	184TC	standard 13-1/16 in. additional sizes available from 18" to 60" in 6" increments	1-5/32	14-3/4	8-1/2
	213TC		1-3/4	15-13/16	10-13/16
	215TC		1-3/4	17-1/4	10-13/16

*Varies with motor manufacturer
Custom lengths available. Contact FTI sales.

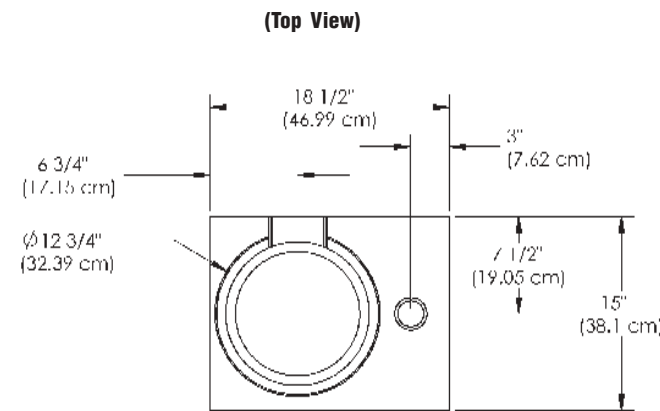

Column Lengths (A12-60)

	A12	A18	A24	A30	A36	A42	A48	A54	A60
inch	13-1/16	18	24	30	36	42	48	54	60
cm	33.2	45.7	61.0	76.2	91.4	106.7	122.0	137.2	152.4

With IEC Motors (Centimeters)

MODEL	MOTOR FRAME	A	B	C*	D*
VKC22	90 IEC	standard 33.19 cm	1.28	27.20	14.00
	100 IEC	additional sizes available from 45.7 cm to 152.4 cm in 15.2 cm increments	1.91	30.80	16.00
	112 IEC		1.91	32.10	16.00
	132 IEC		4.45	37.10	20.00

NOTE: All with B14 motor flange

*Varies with motor manufacturer

Custom lengths available. Contact FTI sales.

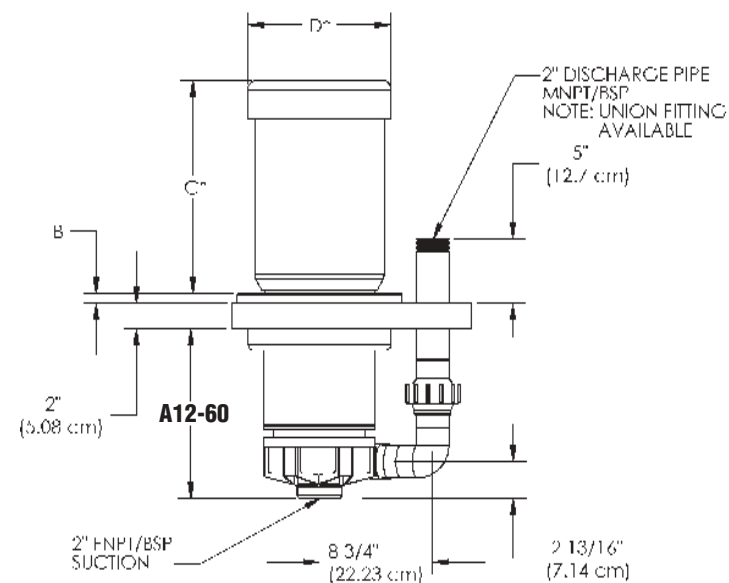

VKC22 VERTIMAG™ Pumps 3.0 to 10 HP (1.5 to 7.5 kW)

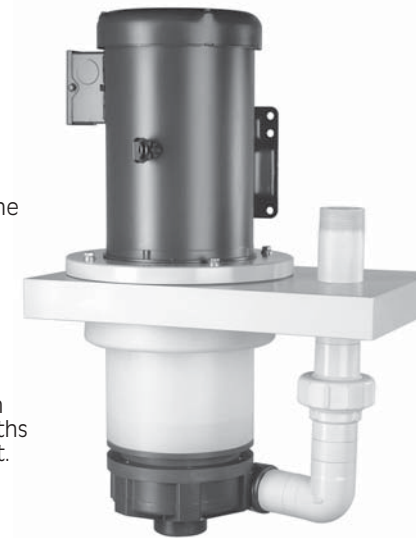

VKC22
Polypropylene

Available in
custom lengths
up to 5 feet.

*Pat. Nos. 5,779,456; 5,708,313

Features

- Powerful neodymium sealless mag drive technology
- No wetted shaft bearings - sealed column is liquid-free
- Leak-free, sealed column - eliminates microbubbles, aeration of fluid, foaming
- No power robbing back impeller vanes
- Reduced environmental emissions - sealed column is fume-free
- Service friendly top pull-out design
- Polypropylene or PVDF construction - excellent chemical resistance
- Viton or EPDM o-rings
- Rugged cantilevered ceramic spindle
- Impeller available in open or closed design - provides maximum hydraulic flexibility
- Carbon, PTFE or ceramic bushing options - provides application flexibility
- 10-minute run-dry capability with carbon bushing
- Available in lengths of 6" increments up to 60" (custom lengths available) - allows precise location in tank or sump
- Accepts standard NEMA or IEC motors (see back page for motor frames)

Specifications

Open Impeller

MODEL (CONSTRUCTION)	SUCTION DISCHARGE	IMPELLER SIZE		MAX. FLOW		MAX. HEAD		MOTOR DRIVE		MAX. S.G. @ 50 cps ^{††}
		inch	cm	3450 rpm gpm	2900 rpm m ³ /hr	3450 rpm ft	2900 rpm m	3450 rpm hp	2900 rpm kw	
VKC2245 (P, V)	2" FNPT/BSP 2" MNPT/BSP	4.5	11.5	180	33	63	14	3.0 - 5.0	1.5 - 3.7	1.8
VKC2250 (P, V)		5.0	12.7	200	36	77	16	5.0 - 7.5	2.2 - 3.7	1.8
VKC2255 (P, V)		5.5	14.0	205	37	97	21	5.0 - 7.5	3.7 - 5.5	1.8
VKC2260 (P, V)		6.0	15.2	241	44	142	29	7.5 - 10.0	3.7 - 7.5	1.3

Closed Impeller

MODEL (CONSTRUCTION)	SUCTION DISCHARGE	IMPELLER SIZE		MAX. FLOW		MAX. HEAD		MOTOR DRIVE		MAX. S.G. @ 50 cps ^{††}
		inch	cm	3450 rpm gpm	2900 rpm m ³ /hr	3450 rpm ft	2900 rpm m	3450 rpm hp	2900 rpm kw	
VKC2245 (P, V)	2" FNPT/BSP 2" MNPT/BSP	4.5	11.5	129	24	73	16	3.0 - 5.0	1.5 - 3.7	1.8
VKC2250 (P, V)		5.0	12.7	149	28	92	20	5.0 - 7.5	2.2 - 3.7	1.8
VKC2255 (P, V)		5.5	14.0	165	31	115	25	5.0 - 7.5	3.7 - 5.5	1.8
VKC2260 (P, V)		6.0	15.2	193	35	142	31	7.5 - 10.0	3.7 - 7.5	1.3
VKC2263 (P, V)		6.375	16.2	201	37	151	33	7.5 - 10.0	3.7 - 7.5	1.0

P - Polypropylene glass filled, carbon, PTFE, high purity ceramic and viton. Maximum temperature 140°F (60°C).

V - PVDF carbon filled, carbon, PTFE, high purity ceramic and viton. Maximum temperature 140°F (60°C).

†† Obtainable without trimming impeller. Contact FTI for handling higher specific gravities.

Performance
Open Impeller

60 Hz 3450 rpm

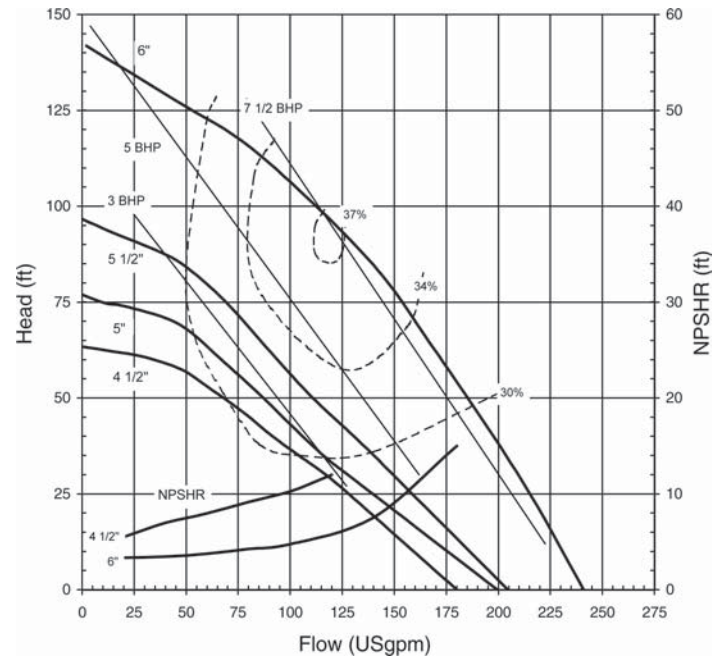

50 Hz 2900 rpm

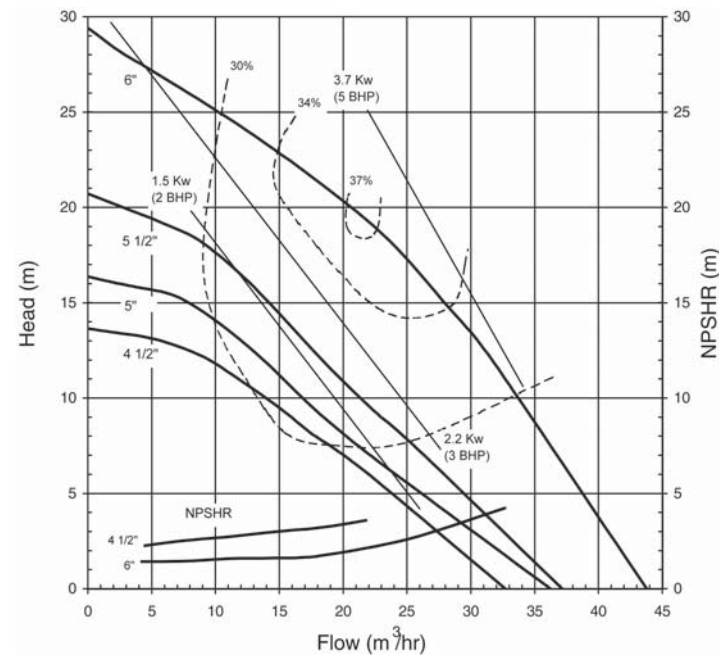

Performance
Closed Impeller

60 Hz 3450 rpm

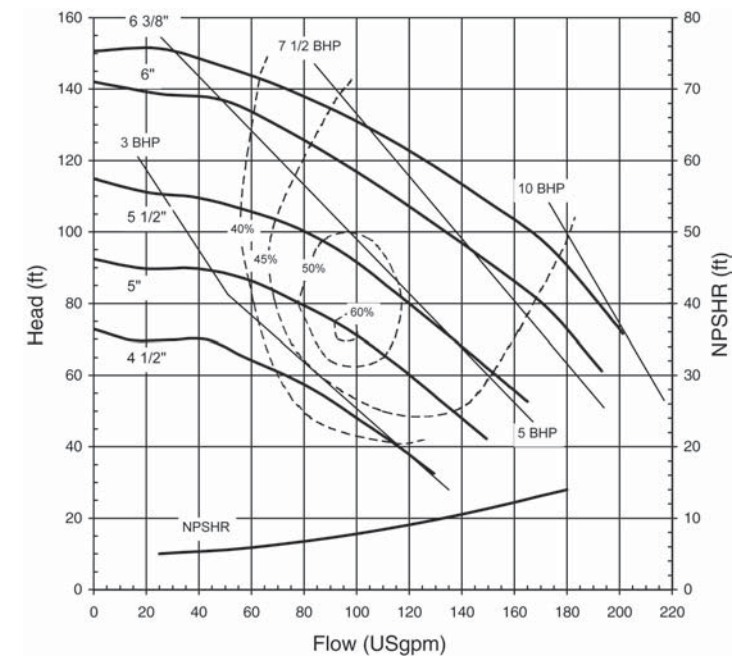

50 Hz 2900 rpm

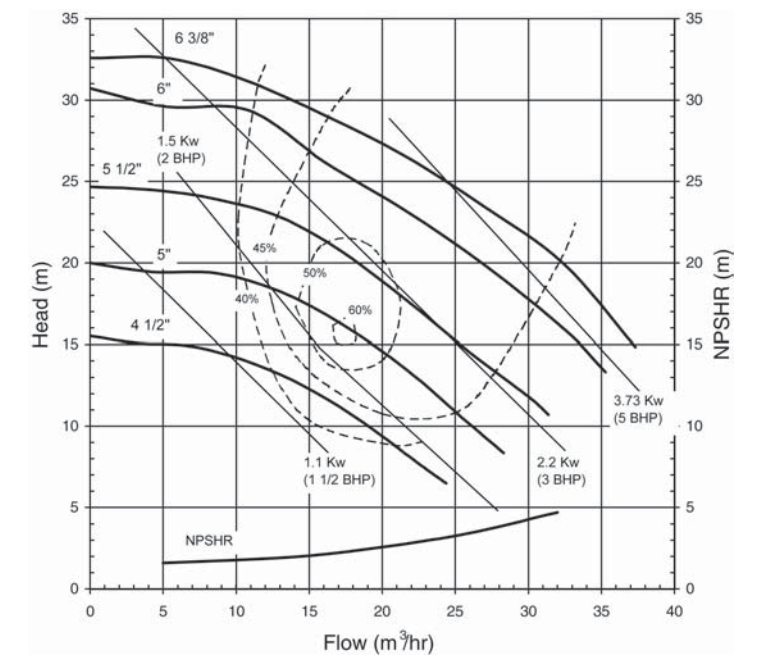

60 Hz 1725 rpm

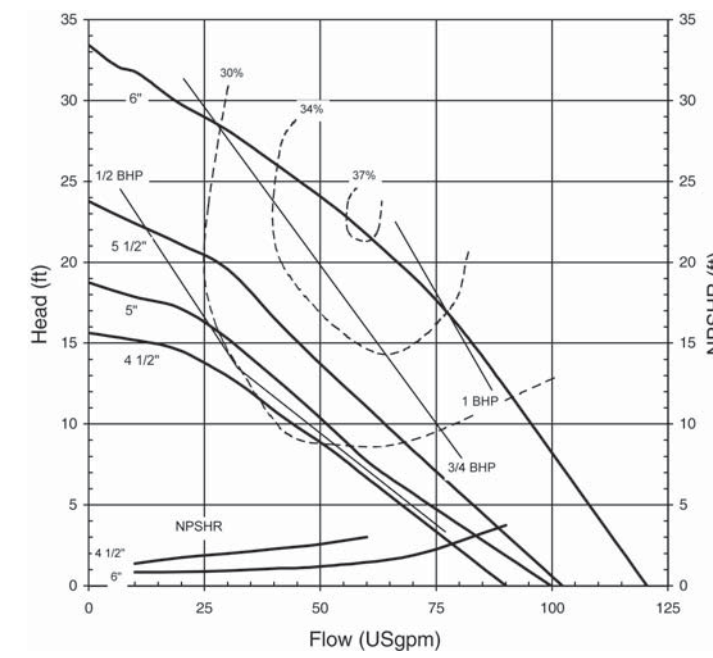

50 Hz 1450 rpm

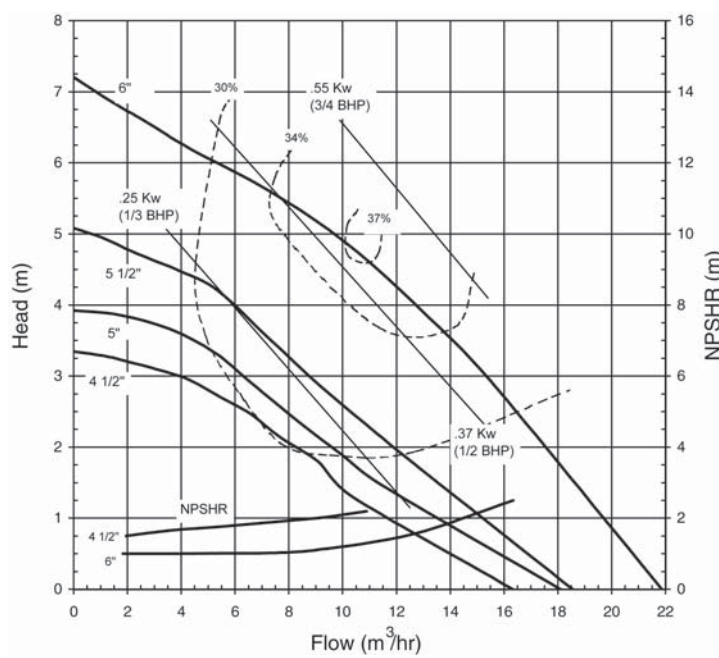

60 Hz 1725 rpm

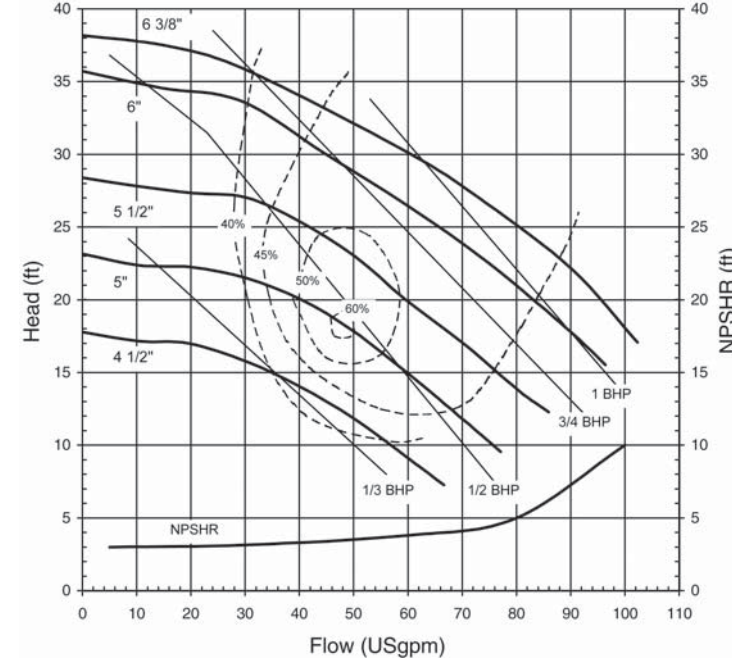

50 Hz 1450 rpm

