

# MACERATORS AND TOILETS

CONTENTS

ENGINE COOLING

INDEX

HOME

NEXT

BACK

## TOILET TROUBLESHOOTING

Depco has compiled a trouble shooting guide to assist you or your customer in solving the most common toilet issues. Check out the toilet section of our website at [www.depcopump.com](http://www.depcopump.com).



## WILCOX CRITTENDEN HEAD

Yes, we even repair heads! It's not our favorite activity but someone has to do it. This old Wilcox is a beauty and with our help it flushes again.



## RARITAN JET HEAD REPLACEMENT PUMP

The Raritan Jet Head has been discontinued for several years. However, we have created a replacement pump assembly that will keep your jet head toilet flushing! It is available in 12vdc, 24vdc, 32vdc and 115/230vac models. This pump has 1 1/2" x 1 1/2" ports, durable and corrosion resistant non-metallic housing and a high flow, high pressure centrifugal impeller.



## DOCKSIDE PUMPOUT MADE EASY

There are several cost effective ways to create your own dockside pump-out system at a fraction of what a prepackaged system would cost. Oberdorfer's one horsepower 406M series (see top of page 52) has a solid bronze housing and macerating chopper blade. It creates tremendous suction and comes with an optional vacuum switch which automatically shuts the pump down once your holding tank is empty. Bosworth's 2800 series (also on page 53) is a dry running diaphragm pump with large duckbill suction and discharge valves that easily passes any solids that make it to the pump. Call us for assistance in designing your dockside pumpout system!

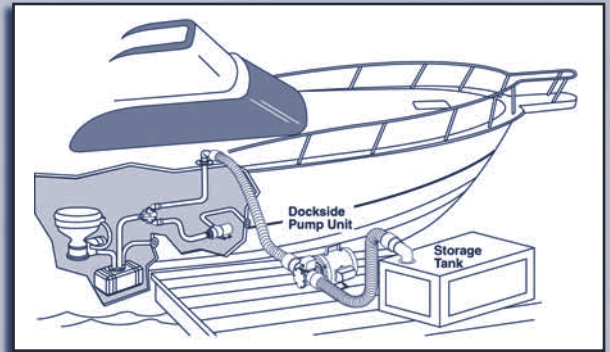

## Y-VALVES IN STOCK

Y-Valves simplify the diverting of water or sewage. They are most often used in holding tank applications to allow the pumping of sewage to a deck fitting for dockside transfer or to overboard discharge when the vessel is far off shore. Jabsco, Whale and Bosworth fittings, in a variety of sizes, are stocked and available for immediate shipment. See page 58.

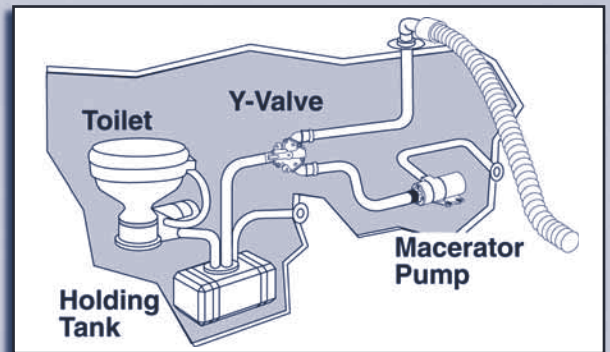

## HOLDING TANK PUMPS THAT CAN RUN DRY!

Flexible impeller pumps are the most commonly used design for transferring sewage from holding tanks. Their only drawback is a lack of ability to run dry. A vacuum or thermal switch can be incorporated to protect the impeller. However, there is a design (diaphragm type) that will operate indefinitely without damage eliminating the need for a protection switch. The compact plastic 59090 series by Jabsco is ideal for on-board holding tank transfer while the rugged bronze or aluminum Bosworth 2800 series will function in on-board or dockside operation. See page 53 for additional information on both models.

