

Jabsco's latest rotary positive displacement pump incorporates the very latest in hygienic design concepts in order to fulfill the ever increasing customer demands for improved cleanability, hygiene and sterilizeability. This 316 stainless steel design uses a bi-wing rotor, which encompasses the very best features of tri-lobe rotor pumps and circumferential piston pumps. The pump is built upon Jabsco's 40 year experience of producing and supplying their Pureflo flexible impeller and 24 series rotary lobe pumps to the world's most demanding markets.

- Up to 180 GPM
- Up 215 PSI
- 316SS construction
- 1 to 1 million CP viscosity
- Bi-wing "Scimitar" rotors
- Nitrile, Viton, EPDM, & PTFE elastomers
- Multiple seal options (see page 7)
- Hydraulic drive available (see page 13)

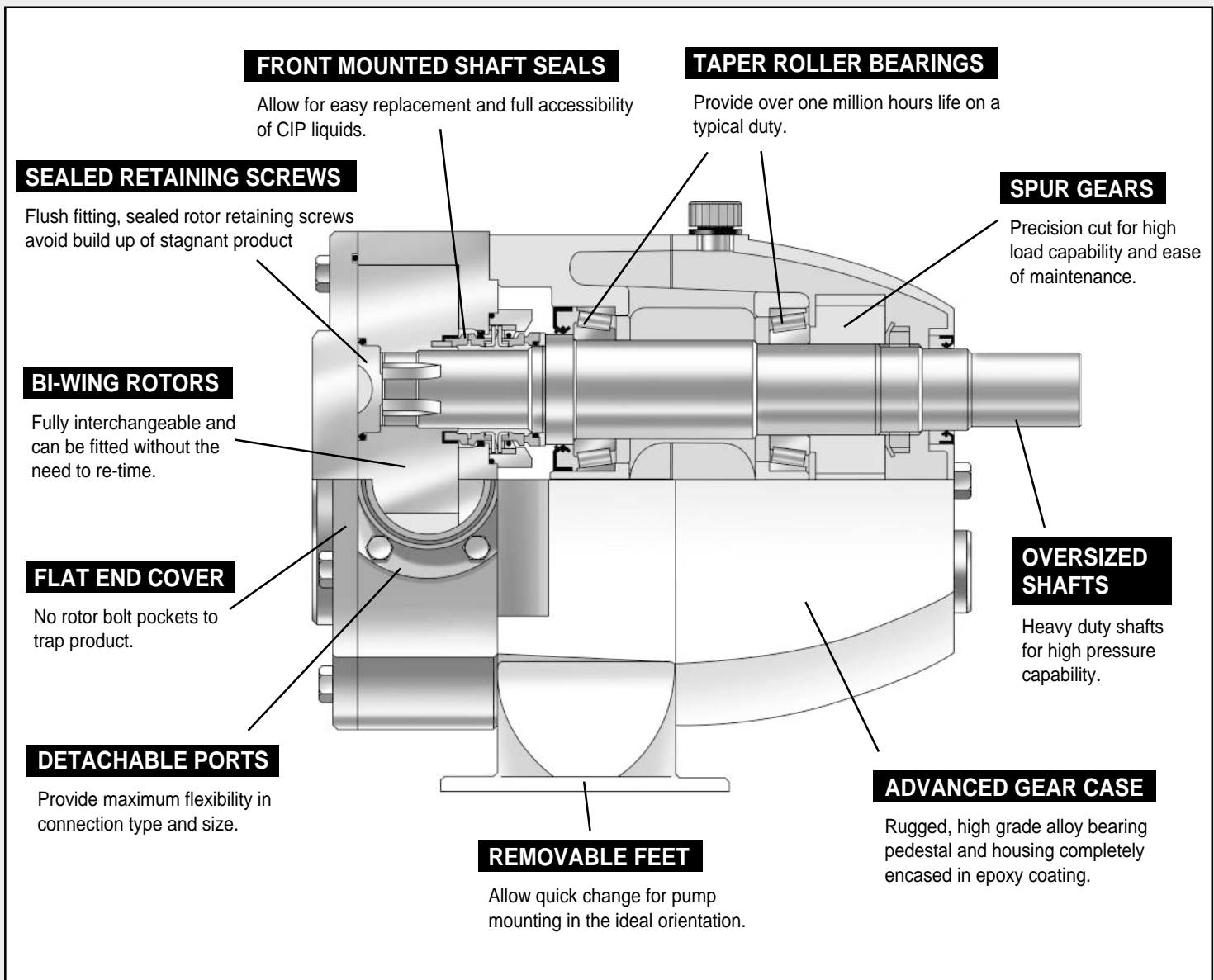

**FOR ENGINEERING AND PUMP SELECTION ASSISTANCE CALL DEPCO AT 1-800-446-1656**