

The Jabsco 24 series range of positive displacement rotary lobe pumps is a proven design spanning nearly 20 years. With thousands of pumps in use around the world, users agree that it is one of the best designed hygienic pumps on the market today. The 316 stainless steel 24 series pump range incorporates improved technology in hygienic pump design and manufacturing techniques, yet utilizes the traditional tri-lobe rotor concept which is so well accepted by the world's leading suppliers of food, personal care, and chemical products.

- Up to 217 PSI
- Up 554 GPM
- 316SS construction
- 1 to 1 million CP viscosity
- Tri-lobe & Bi-lobe rotors available
- Nitrile, Viton, EPDM, PTFE & Kalrez elastomers
- Multiple seal options (see page 5)
- Hydraulic drive available (see page 13)

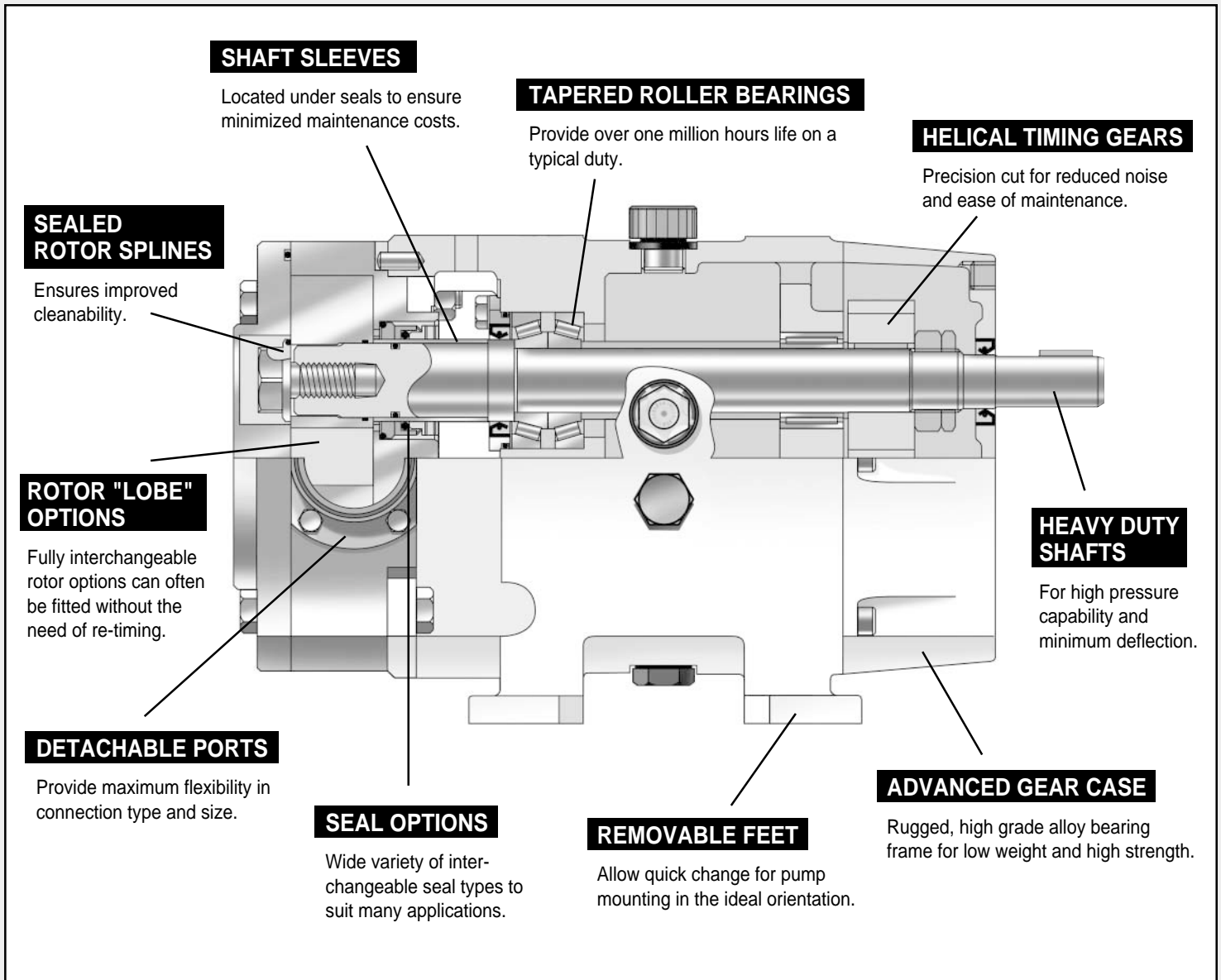

FOR ENGINEERING AND PUMP SELECTION ASSISTANCE CALL DEPCO AT 1-800-446-1656