

Gear pumps offer great priming, smooth flow, and medium pressures. Cast iron versions typically are applied for lubricating liquids while the bronze and stainless series are often utilized in mild to aggressive chemicals from low to high viscosity. Gear types include internal, external spur, helical, and herringbone, all of which are capable of delivering uniform, pulseless flow on products from kerosene to corn syrup. (See sanitary models on pages 102 & 104).

PRECISION PASTE FEED



This slow turning, adjustable speed gear motor is operating an Oberdorfer bronze gear pump to apply edge paste to drywall in a continuous feed operation. (See pages 12-16 for other Oberdorfer gear pumps).

METERING MAGNETIC DRIVE

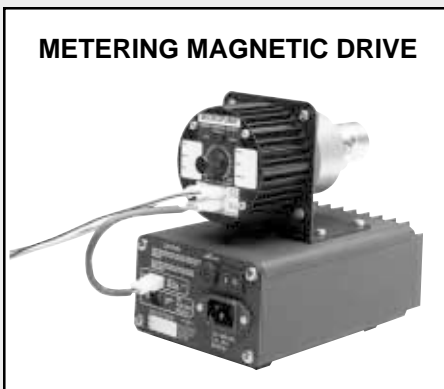

This mag drive gear pump from Micropump is driven by a low voltage brushless DC motor complete with AC power supply. It can track a control signal and furnish feedback too! (See pages 6-9).

PROCESS BASEMOUNT

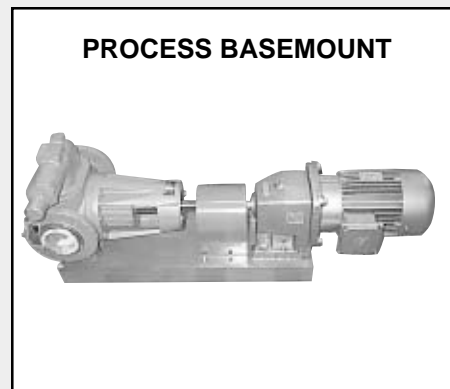

Tuthill's ST internal gear pump offers a back pull-out modular design which satisfied this customer's requirement to service the pump without disrupting the plumbing! (See page 20).

CLUTCH DRIVE

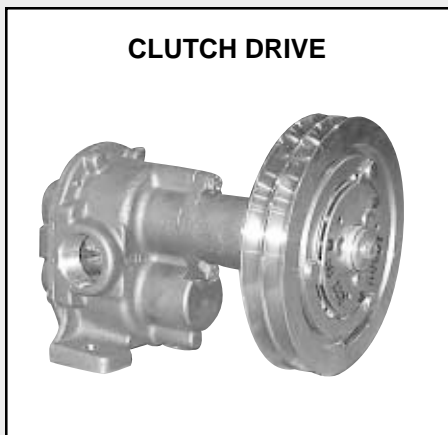

Driven by an electric clutch, this bronze Oberdorfer gear pump makes a great fire pump. It is also used on trucks for on and off loading. It primes like crazy and will deliver up to 80 GPM at 100 psi! (See page 16).

VARIABLE, PULSELESS FLOW



This 1/4" stainless steel gear pump with a Teflon seal was the ideal choice to deliver an adjustable flow of 400° F oil. It supplies a smooth pulseless flow from .2 to 2 gpm at up to 100 psi. (See pages 10-11).

REVERSIBLE GEAR



Most gear pumps can reverse rotation. This pump has the reverse switch prewired, making it an ideal pump to fill and empty oil and other compatible liquids. A handle is available to make it portable!