

DIAPHRAGM / OSCILLATING FAMILY

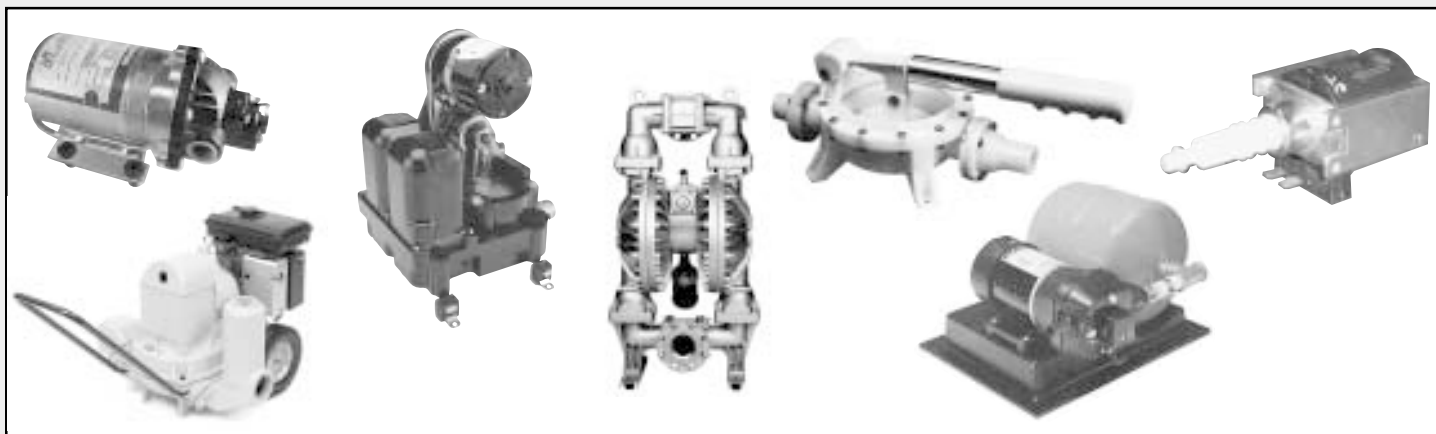

Diaphragm pumps are self-priming, dry running, and will pass solids when they are fitted with the appropriate valves. Models range from 1/4", 12 vdc, 150 psi pressure switch controlled spray pump to a 3" engine driven, solids handling "Mud Hog"! Oscillating pumps are miniature, self-priming spray or transfer pumps that operate without a motor. They create motion by utilizing alternating current to energize a field coil. (See page 4 to find out more details)

SINGLE DIAPHRAGM



Sewage – Sumps – Ditches
 20 foot lift – 20 gallons per minute
 115/230 vac – 230/460 vac – 12 or 24 vdc
 (See page 40)

AC & DC MINI-DIAPHRAGM

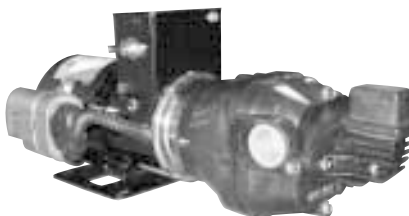

This unusual looking pump is a 115 vac, brushless, self-priming, continuous duty, diaphragm pump. It even comes with a pressure activated demand switch! (See pages 36-39 for more selections.)

1/4" AOD



1/4", 3 gallons per minute, Polypropylene and Teflon, self-priming, run dry, variable speed, and inexpensive. Everybody needs at least one! (See page 33)

OSCILLATING PUMP

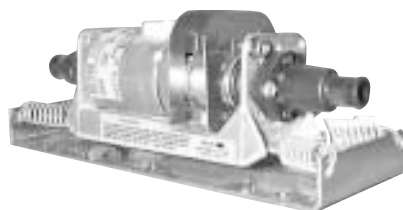

Yes, this is what an oscillating pump looks like. It's a unique self-priming and compact pump design for low flow, low to high pressure applications. On page 4 you can see how it works. (See pages 41-42)

UL LISTED FUEL AOD



This Yamada pump is listed by Underwriters Laboratories as a fuel transfer pump. It comes in 3/4" or 1" ports, will pump up to 49 GPM and runs on compressed air. (See page 35)

BOTTLED WATER PUMP



This complete system will deliver bottled water to your refrigerator's icemaker and your tap! It is available in 115 vac and 12 vdc. (See page 133)