

Jabco's self-priming flexible impeller pump design can effectively handle thin, viscous, shear sensitive, abrasive, particle-laden, and air-entrained fluids with ease. Each pump is equipped with a mechanical seal (hardened seal optional) and a flexible impeller of Neoprene, Nitrile (Buna), EPDM or Viton. Their versatile mounting options include close-coupled C-Face in 56C, 145TC, 182TC and 184TC as well as pedestal mounting for base mount and pulley drive applications. Variable speed and gear reduction assemblies are available to meet your specific requirements.

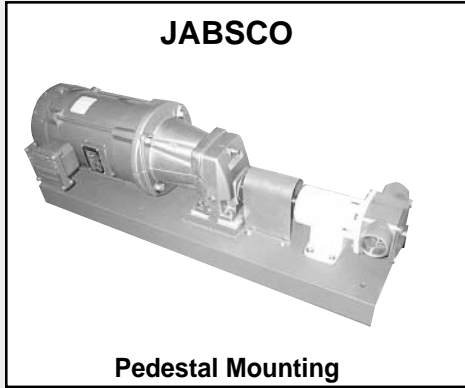

This versatile mounting allows in-line or offset mounting with coupling, gear or pulley to your required drive. Each pedestal unit has a heavy duty drive frame with spaced double ball bearings.

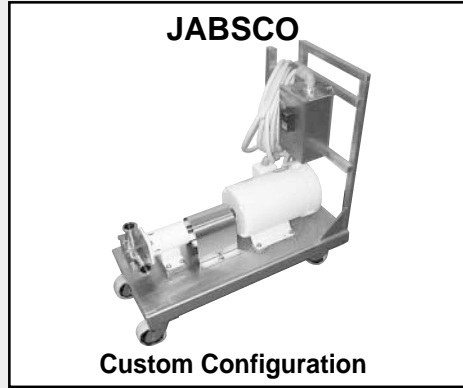

We will provide a complete assembly to meet your specific requirements with options that include variable speed drive, cart mounting, gear reduction and numerous voltages and enclosures.

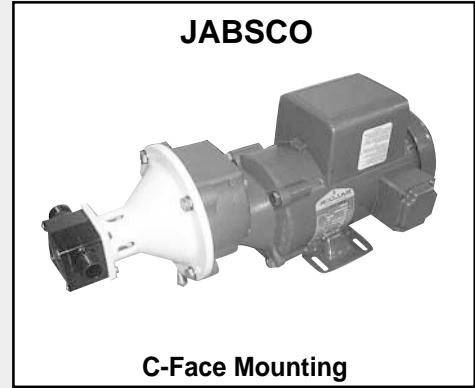

The C-face mounting option offers the most compact and efficient assembly. Numerous drives are available in AC or DC, hydraulic or pneumatic.

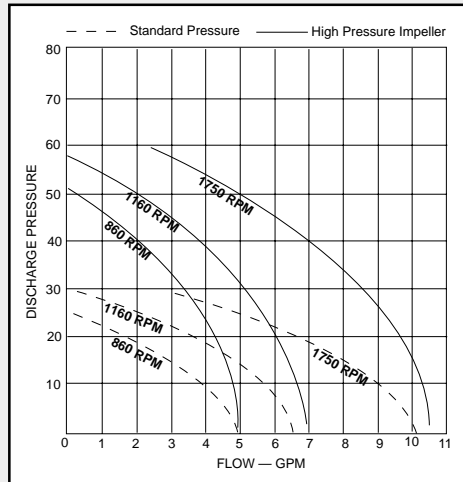

**UP TO 10 GPM, 60 PSI, IN 316 STAINLESS STEEL**

- Temperatures to 185° F
- Construction: 316SS
- Elastomer Options: Carbon/Ceramic or Tungston/Ceramic mechanical seal with Nitrile or Viton rubber
- Impeller Options: Neoprene, Nitrile, Viton and EPDM
- Mounting Options: AC and DC voltages, TEFC, washdown, explosion proof, gear reduction, variable speed drive and other custom configurations

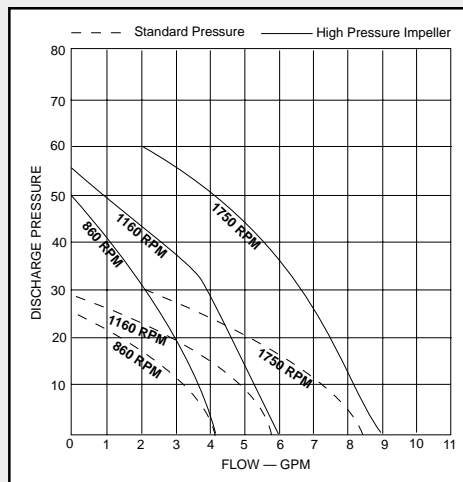

**UP TO 10 GPM, 60 PSI, IN EPOXY**

- Temperatures to 185° F
- Construction: Epoxy housing (no metal to liquid contact)
- Elastomer Options: Carbon/Ceramic or Tungston/Ceramic mechanical seal with Nitrile or Viton rubber
- Impeller Options: Neoprene, Nitrile, Viton and EPDM
- Mounting Options: AC and DC voltages, TEFC, washdown, explosion proof, gear reduction, variable speed drive and other custom configurations

**FOR ENGINEERING AND PUMP SELECTION ASSISTANCE CALL DEPCO AT 1-800-446-1656**