

VALVE & FITTING FRICTION

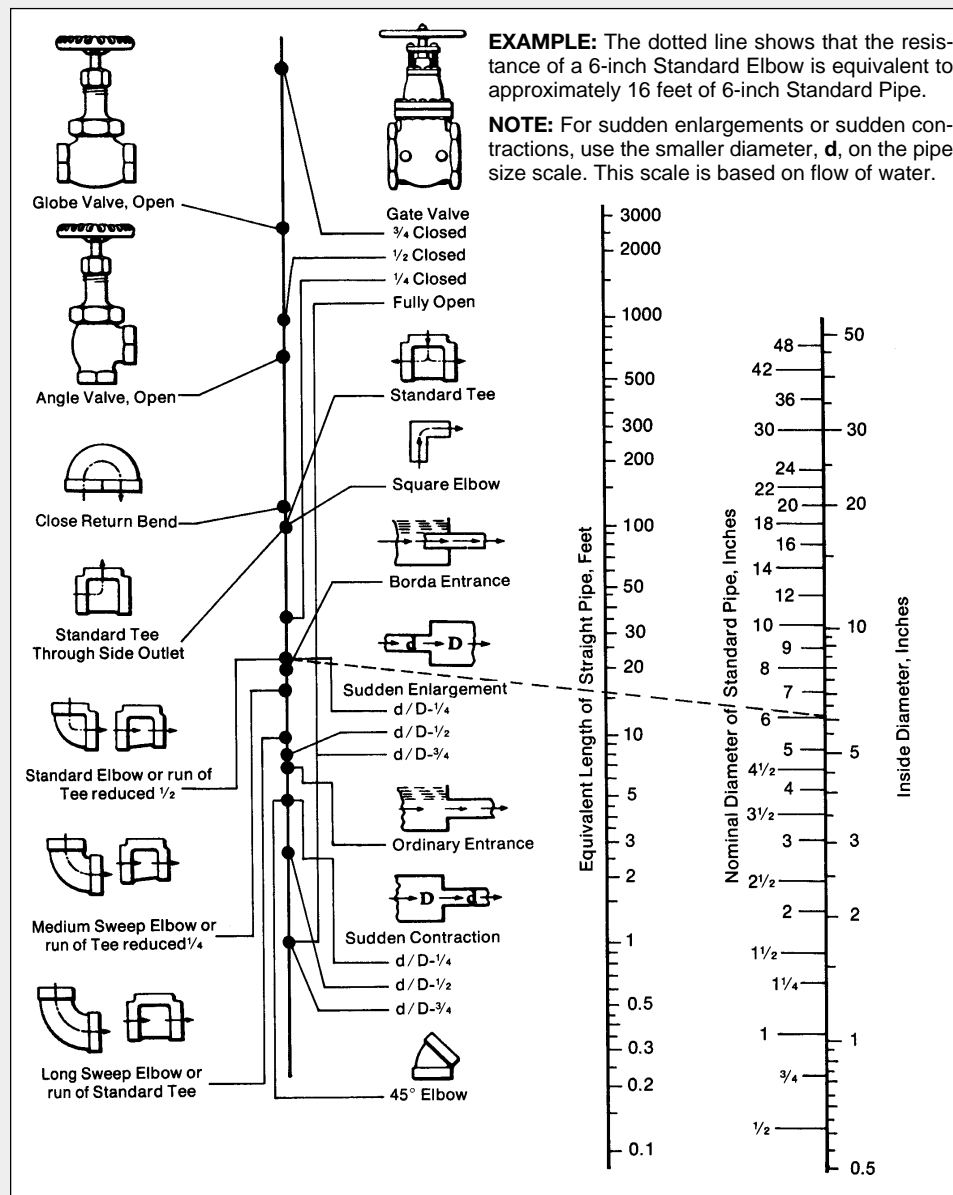

FAHRENHEIT TO CENTIGRADE

Degrees Fahrenheit	Degrees Centigrade
+212°F.	+100°C.
+203	+95
+194°F.	+90°C.
+185	+85
+176°F.	+80°C.
+167	+75
+158°F.	+70°C.
+149	+65
+140°F.	+60°C.
+131	+55
+122°F.	+50°C.
+113	+45
+104°F.	+40°C.
+95	+35
+86°F.	+30°C.
+77	+25
+68°F.	+20°C.
+59	+15
+50°F.	+10°C.
+41	+5
+32°F.	0°C.
+23	-5
+14°F.	-10°C.
+5	-15
-4°F.	-20°C.
-13	-25
-22°F.	-30°C.
-31	-35
-40°F.	-40°C.

EFFECT OF ELEVATION TO SUCTION LIFT

It is important to factor in elevation when applying a self-priming pump. Please refer to the below table to identify the applicable suction lift reduction.

Altitude Above Sea Level	Atmospheric Pressure Pounds/Sq. in.	Equivalent Head or Water Feet	Reduction to Max. Practical Dyn. Suction Lift
0	14.7	33.95	0 ft.
1000	14.2	32.7	1.2 ft.
2000	13.6	31.6	2.3 ft.
3000	13.1	30.2	3.7 ft.
4000	12.6	29.1	4.8 ft.
5000	12.1	27.9	6 ft.
6000	11.7	27.0	6.9 ft.
7000	11.2	25.9	8 ft.
8000	10.5	24.9	9 ft.

VACUUM MEASUREMENT

The term vacuum or suction is commonly used to indicate a pressure below normal atmospheric pressure (14.7 psia). Vacuum is often expressed as the difference between measured system pressure and atmospheric pressure.

