

# FINISH THOMPSON DRUM PUMPS

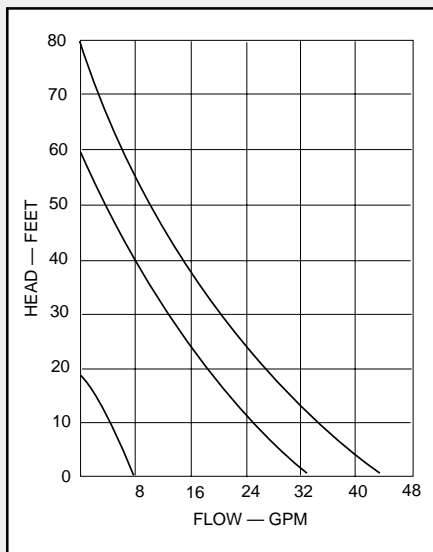

## POLYPRO, PVDF AND 316SS DRUM PUMPS

These sealless pumps handle acids, caustics, chemicals and flammables of up to 1.8 specific gravity and 500 centipoise.

- Up to 42 GPM
- Up to 80 TDH
- Up to 500 centipoise
- Up to 1.8 specific gravity
- Temperatures to 160° F (Polypropylene)
- Temperatures to 220° F (316 Stainless)
- Unique double suction design

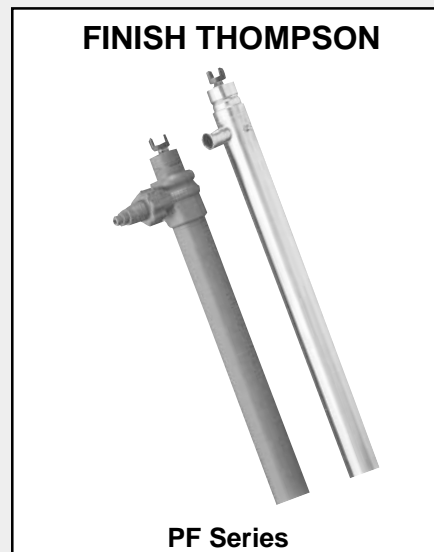

PF Series

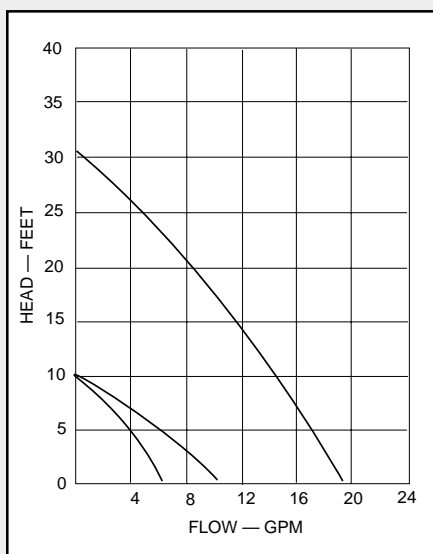

## MEDIUM VISCOSITY HANDLING IN CPVC AND 316SS

These sealed pumps handle mild corrosives, solvents, flammables and sanitary (see page 105) liquids of up to 1.8 specific gravity. Designed for semi-viscous liquids, inks, detergents, vinegar and motor oils.

- Up to 16 GPM (air), 10 GPM (electric)
- Up to 30 TDH
- Up to 2000 centipoise with air motor
- Up to 400 centipoise with electric motor
- Up to 1.8 specific gravity
- Temperatures to 150° F

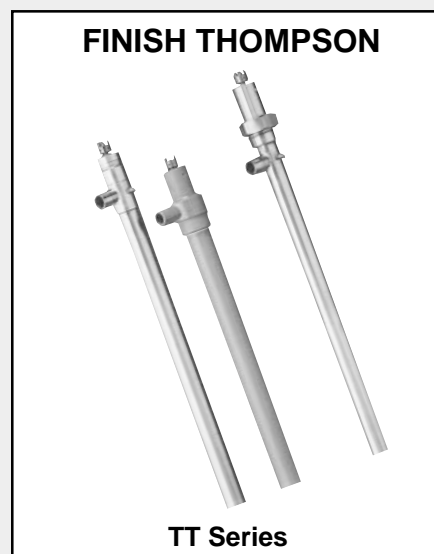

TT Series

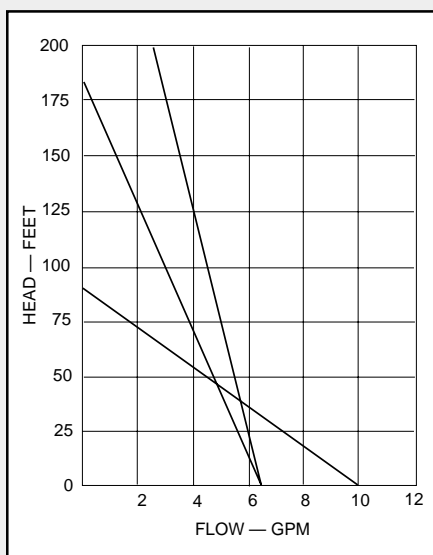

## HIGH VISCOSITY HANDLING IN 316 STAINLESS

These sealed pumps are rated for mild corrosives and flammables of high viscosity in applications which require high head. Designed for high viscosity polymer, adhesives, oils, resins and flammable liquids.

- Up to 10 GPM
- Up to 200 TDH
- Up to 15000 centipoise
- Up to 1.8 specific gravity
- Temperatures to 200° F

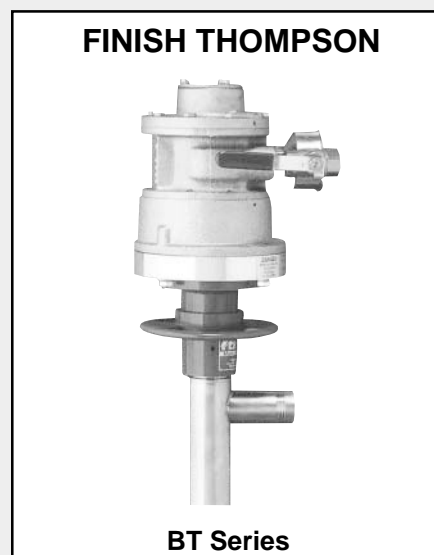

BT Series