

MACERATORS AND TOILETS

CONTENTS

ENGINE COOLING

INDEX

HOME

NEXT

BACK

DOCKSIDE PUMPOUT MADE EASY

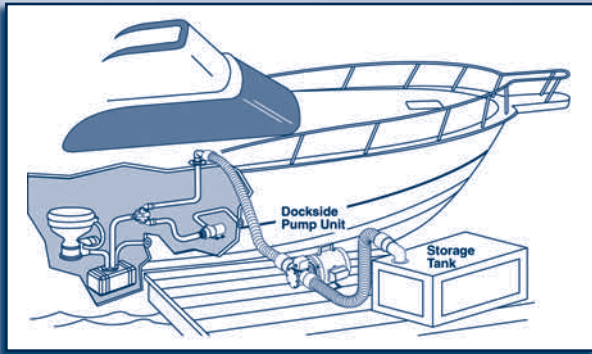

There are several cost effective ways to create your own dockside pump-out system at a fraction of what a prepackaged system would cost. Oberdorfer's one horsepower 406M series (see top of page 52) has a solid bronze housing and macerating chopper blade. It creates tremendous suction

and comes with an optional vacuum switch which automatically shuts the pump down once your holding tank is empty. Bosworth's 2800 series (page 53) is a dry running diaphragm pump with large duckbill suction and discharge valves that easily passes any solids that make it to the pump. Call us for assistance in designing your dockside pumpout system!

Y-VALVES IN STOCK

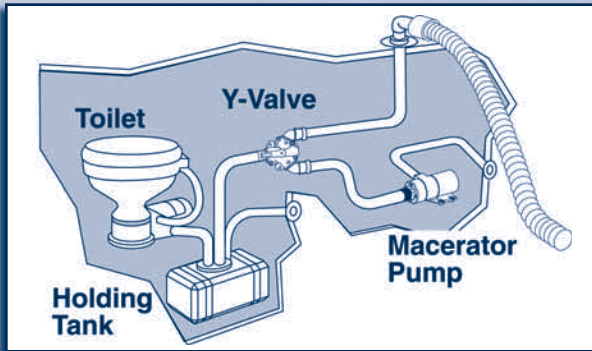

Y-Valves simplify the diverting of water or sewage. They are most often used in holding tank applications to allow the pumping of sewage to a deck fitting for dockside transfer or to overboard discharge when the vessel is far off shore. Jabsco, Whale and Bosworth fittings, in a variety of sizes, are stocked

and available for immediate shipment. See page 60.

HOLDING TANK PUMPS THAT CAN RUN DRY!

Flexible impeller pumps are the most commonly used design for transferring sewage from holding tanks. Their only drawback is a lack of ability to run dry. A vacuum or thermal switch can be incorporated to protect the impeller. However, there is a design (diaphragm type) that will operate indefinitely without damage eliminating the need for a protection switch.

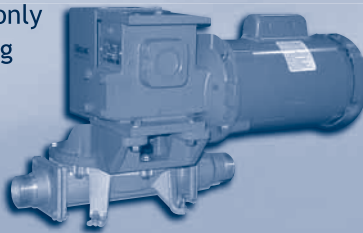

The compact plastic 59090 series by Jabsco is ideal for on-board holding tank transfer while the rugged bronze or aluminum Bosworth 2800 series will function in on-board or dockside operation. See page 53 for additional information on both models.

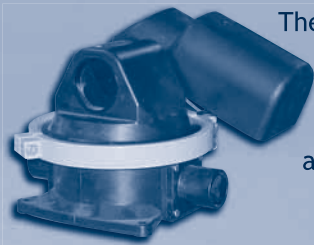

Macerators	52, 78
Manual Transfer	60, 79
Sewage Transfer	52, 53, 78, 79
Toilet Conversion Kits	55, 56, 58
Water Heater	59
Waste Treatment	59
Y-Valves	60
Toilets	
Groco	57
Galley Maid	57
Jabsco	54-56
Raritan	58, 59
Sealand (pumps)	57
Toilet Parts	
Groco	162
Galley Maid	57, 159
Jabsco	159-161

RARITAN JET HEAD REPLACEMENT PUMP

The Raritan Jet Head has been discontinued for several years. However, we have created a replacement pump assembly that will keep your jet head toilet flushing! It is available in 12vdc, 24vdc, 32vdc and 115/230vac models. This pump has 1 1/2" x 1 1/2" ports, durable and corrosion resistant non-metallic housing and a high flow, high pressure centrifugal impeller.



WILCOX CRITTENDEN HEAD

Yes, we even repair heads! It's not our favorite activity but someone has to do it. This old Wilcox is a beauty and with our help it flushes again.

