

EXPLODED VIEW & PARTS LISTING

Air Operated Double Diaphragm Pump

Model: NDP-80BPT

Model#: 852246



To Purchase:

☎ 800-990-7867

✉ sales@yamadapump.com

📍 Find My Rep

More Information:

▶ YouTube: @yamadapump

🌐 yamadapump.com

*Data Sheets | CAD Drawings | Manuals
Literature | BOM | Performance Curves*

Trial Program

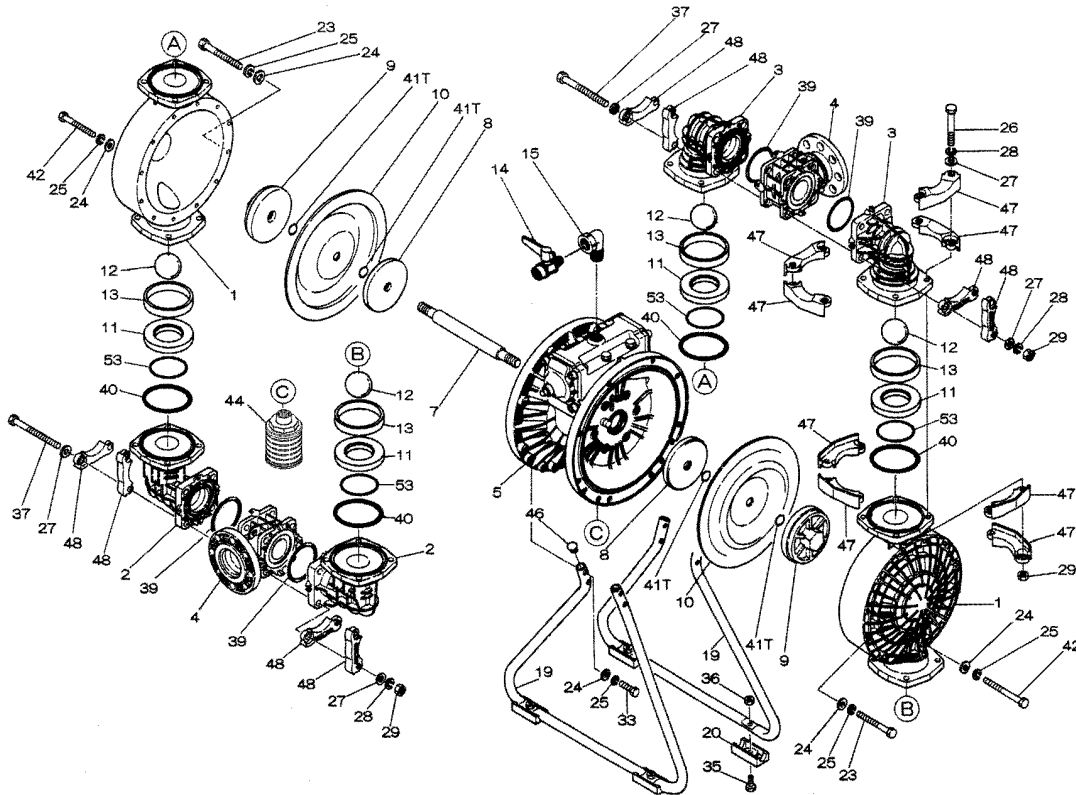

Air Operated Double Diaphragm Pump

■ Body Assembly

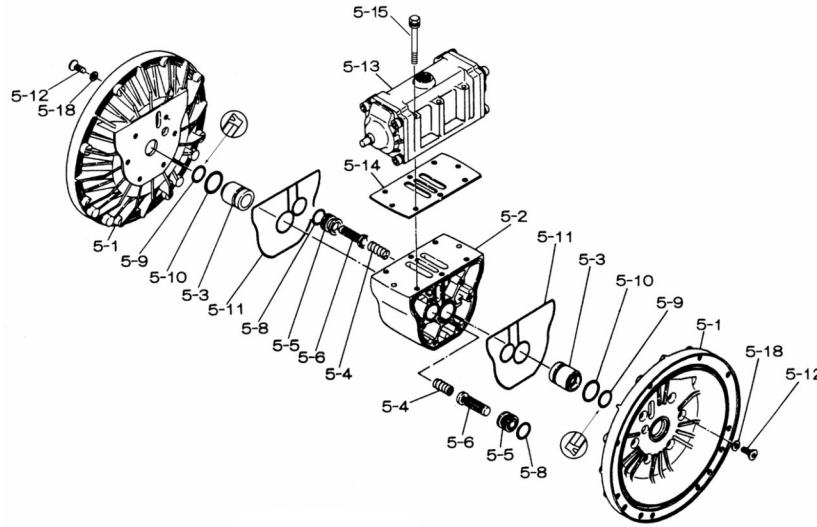

■ Valve Body Assembly

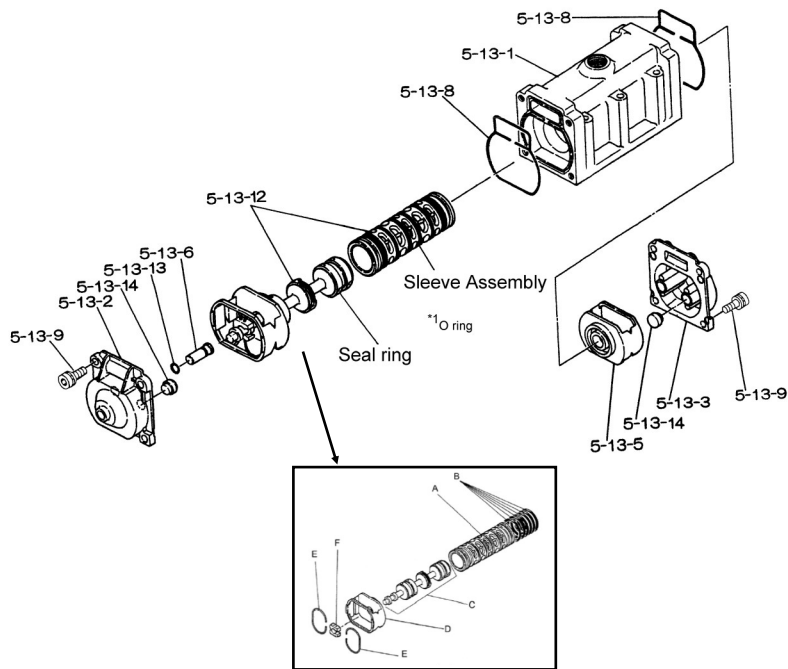

Air Operated Double Diaphragm Pump

REF. No.	PARTS No.	DESCRIPTION	QTY.	REORDER
1	780149	OUT CHAMBER	2	
2	780246	IN MANIFOLD	2	
3	780152	OUT MANIFOLD	2	
4	780250	CENTER MANIFOLD	2	
5	803113	CENTER BODY ASSY.	1	
5- 1	711935	AIR CHAMBER	2	
5- 2	711936	BODY	1	
5- 3	772689	THROAT BEARING	2	
5- 4	711937	PILOT VALVE SPRING	2	
5- 5	771740	PILOT VALVE SEAT	2	
5- 6	832163	PILOT VALVE ASSY.	2	
5- 8	640020	O-RING	2	
5- 9	685444	V-PACKING	2	
5-10	640029	O-RING	2	
5-11	771742	GASKET	2	
5-12	683812	FLAT SOCKET	12	
5-13	802971	VALVE BODY ASSY.	1	
5-13-1	711931	VALVE BODY	1	
5-13-2	580999	CAP A	1	
5-13-3	581000	CAP B	1	
5-13-5	771735	SPRING RETAINER	1	
5-13-6	712976	RESET BUTTON	1	
5-13-8	771738	GASKET	2	
5-13-9	685036	SOCKET BOLT	8	
5-13-12	805084	C-SPOOL ASSY	1	
A	803675	SLEEVE ASSY	1	
B	640036	O-RING	6	
C	805085	SPOOL ASSY	1	
D	771735	SPRING RETAINER	1	
E	711932	C-SPRING	2	
F	771734	BLOCK	1	
5-13-13	640005	O-RING	1	
5-13-14	684128	CUSHION	4	
5-14	771712	GASKET	1	
5-15	684240	BOLT W/WASHERS	6	
5-18	684987	WASHER	12	
7	711940	CENTER ROD	1	
8	711041	CENTER DISK	2	
9	771730	CENTER DISK	2	
10	770934	DIAPHRAGM 50N	2	
11	772098	VALVE SEAT 50N	4	
12	770694	BALL 50N	4	
13	772099	VALVE SPACER	4	
14	684322	BALL VALVE	1	
15	682523	ELBOW	1	
19	711927	BASE	2	
20	771865	FOOT RUBBER	4	
23	683543	BOLT	20	

REF. No.	PARTS No.	DESCRIPTION	QTY.	REORDER
24	631330	FLAT WASHER	32	
25	680257	WAVE WASHER	32	
26	621213	BOLT	16	
27	631331	FLAT WASHER	32	
28	680607	WAVE WASHER	24	
29	628014	NUT	24	
33	621179	BOLT	8	
35	621149	BOLT	4	
36	683837	NUT W/FLANGE	4	
37	683544	BOLT	8	
39	643070	O-RING	4	
40	643080	O-RING	4	
41T	643015	O-RING	4	
42	683552	BOLT	4	
44	804764	SILENCER ASSY.	1	
46	683641	CAP	4	
47	771789	PROTECTOR A	32	
48	771790	PROTECTOR B	24	
53	643143	O-RING	4	
KIT	K80-PT	LIQUID SIDE KIT		
KIT	K80-AM	AIR MOTOR KIT		

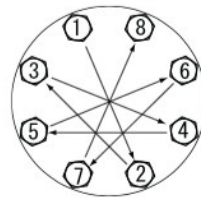

Tightening torque for center rod and out chambers.
Center Rod 36 ft-lbf {50 N-m}
Out Chambers 26 ft-lbf {35 N-m}

Tightening torque for manifold retainer bolts.
BPT 18 ft-lbf {25 N-m}

General Tools:

- Socket wrenches - 13mm, 17mm, 19mm
- Hexagonal box wrench - 5mm, 6mm
- Plastic Hammer

Special Tools:

- Disc remover (771868) used for removing the center disc. (sold separately)
- Sleeve remover (713180) used for removing the sleeve. (sold separately)

Miscellaneous:

- Assembly Oil - turbine oil none additional class 1 (equivalent to ISA VGA32 grade)
- Nuts - M16 x 1.5
- Thread locker
- Urea grease grade (NLGI) No. 2

Customer Notes

Model #: _____

Description: _____

Serial #: _____

Date Installed: _____

Department Location: _____

Tag/Project: _____