

EXPLODED VIEW & PARTS LISTING

Air Operated Double Diaphragm Pump

Model: NDP-80BFT

Model#: 852857



To Purchase:

☎ 800-990-7867

✉ sales@yamadapump.com

📍 Find My Rep

More Information:

▶ YouTube: @yamadapump

🌐 yamadapump.com

Data Sheets | CAD Drawings | Manuals
Literature | BOM | Performance Curves

Trial Program

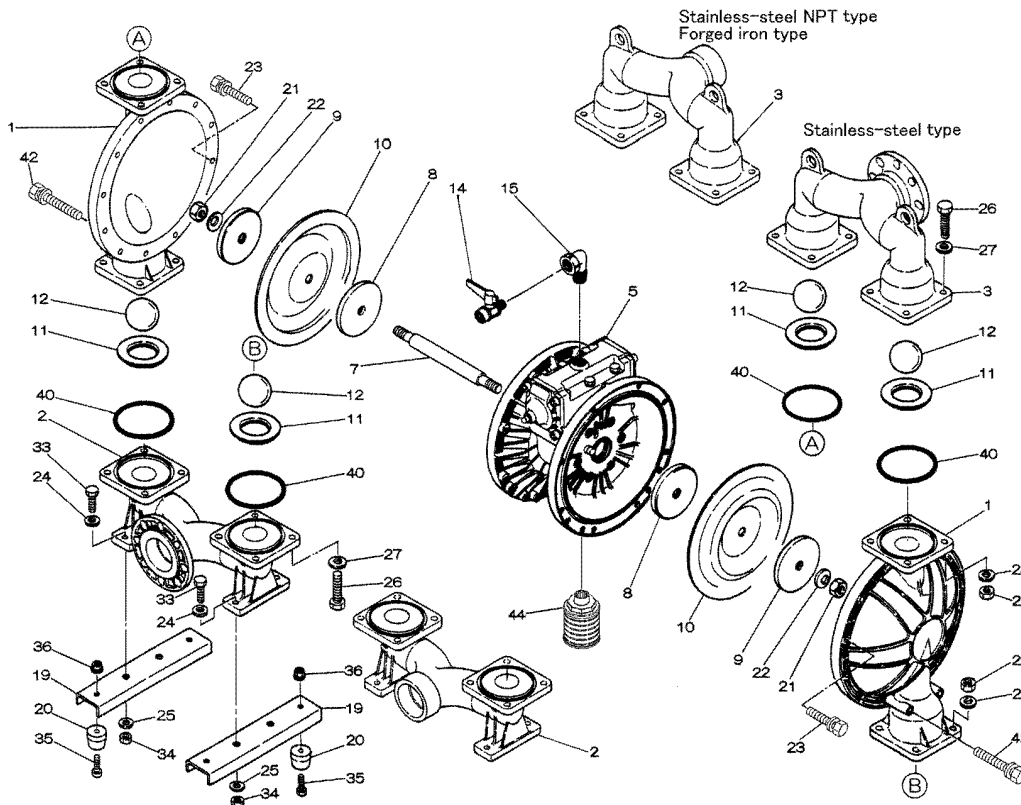

Air Operated Double Diaphragm Pump

■Body Assembly



■Valve Body Assembly

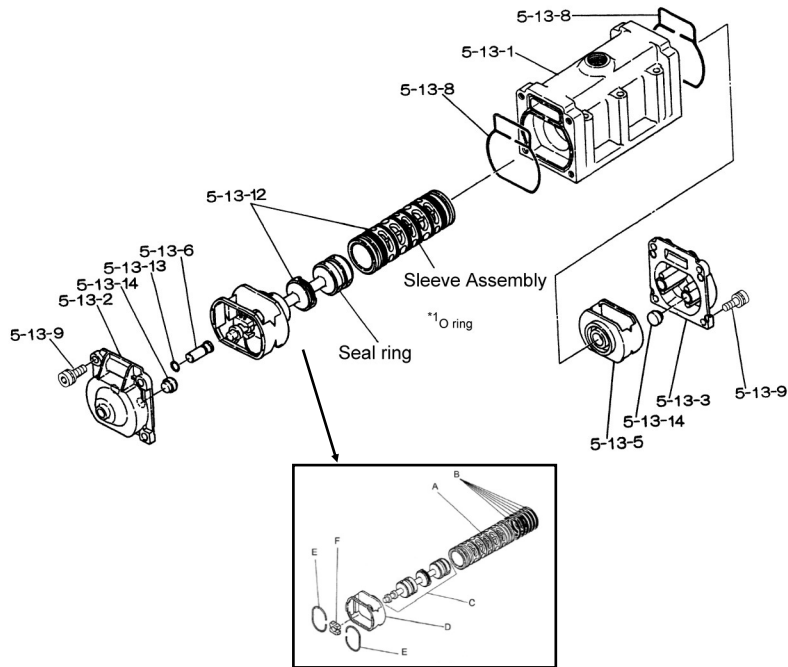

Air Operated Double Diaphragm Pump

REF. No.	PARTS No.	DESCRIPTION	QTY.	REORDER
1	713158	OUT CHAMBER	2	
2	713170	IN MANIFOLD (NPT)	1	
3	713167	OUT MANIFOLD (NPT)	1	
5	803113	CENTER BODY ASSY.	1	
5- 1	711935	AIR CHAMBER	2	
5- 2	711936	BODY	1	
5- 3	772689	THROAT BEARING	2	
5- 4	711937	PILOT VALVE SPRING	2	
5- 5	771740	PILOT VALVE SEAT	2	
5- 6	832163	PILOT VALVE ASSY.	2	
5- 8	640020	O-RING	2	
5- 9	685444	V-PACKING	2	
5-10	640029	O-RING	2	
5-11	771742	GASKET	2	
5-12	683812	FLAT SOCKET	12	
5-13	802971	VALVE BODY ASSY.	1	
5-13-1	711931	VALVE BODY	1	
5-13-2	580999	CAP A	1	
5-13-3	581000	CAP B	1	
5-13-5	771735	SPRING RETAINER	1	
5-13-6	712976	RESET BUTTON	1	
5-13-8	771738	GASKET	2	
5-13-9	685036	SOCKET BOLT	8	
5-13-12	805084	C-SPOOL ASSY.	1	
A	803675	SLEEVE ASSY.	1	
B	640036	O-RING	6	
C	805085	SPOOL ASSY.	1	
D	771735	SPRING RETAINER	1	
E	711932	C-SPRING	2	
F	771734	BLOCK	1	
5-13-13	640005	O-RING	1	
5-13-14	684128	CUSHION	4	
5-14	771712	GASKET	1	
5-15	684240	BOLT W/WASHERS	6	
5-18	684987	WASHER	12	
7	711940	CENTER ROD	1	
8	711041	CENTER DISC	2	
9	713391	CENTER DISC	2	
10	770934	DIAPHRAGM	2	
11	711910	VALVE SEAT	4	
12	770694	BALL	4	
14	684322	BALL VALVE	1	
15	682523	ELBOW	1	
19	711912	BASE	2	
20	771402	FOOT RUBBER	4	
21	706144	NUT	2	
22	682740	WASHER	2	
23-a	686161	BOLT	20	
23-b	631917	WAVE WASHER	20	

REF. No.	PARTS No.	DESCRIPTION	QTY.	REORDER
24	631014	FLAT WASHER	4	
25	631917	WAVE WASHER	4	
26	611204	BOLT	16	
27	631015	FLAT WASHER	16	
28	631918	WAVE WASHER	16	
29	627014	NUT	16	
33	611177	BOLT	4	
34	627013	NUT	4	
35	611149	BOLT	4	
36	682276	NUT W/FLANGE	4	
40	643078	O-RING	4	
41T	643015	O-RING	4	
42-a	686164	BOLT	4	
42-b	631917	WAVE WASHER	4	
44	804764	SILENCER ASSY.	1	
53T	643145	O-RING	4	
KIT	K80-MT	LIQUID SIDE KIT		
KIT	K80-AM	AIR MOTOR KIT		

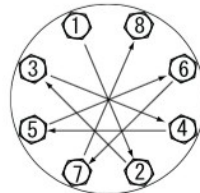

Tightening torque for center rod and out chambers.

Center Rod 43 ft-lbf {60 N-m}
Out Chambers 29 ft-lbf {40 N-m}

Tightening torque for manifold retainer bolts.
BFT 15 ft-lbf {20 N-m}

General Tools:

- Socket wrenches - 24mm
- Hexagonal box wrench - 5mm, 6mm
- Open-end wrenches - 19mm, 24mm
- Plastic hammer

Special Tools:

- Sleeve remover (713180) used for removing the sleeve. (sold separately)

Miscellaneous:

- Assembly Oil - turbine oil none additional class 1 (equivalent to ISA VGA32 grade)
- Nuts - M16 x 1.5
- Thread locker
- Urea grease grade (NLGI) No. 2

Customer Notes

Model #: _____

Description: _____

Serial #: _____

Date Installed: _____

Department Location: _____

Tag/Project: _____