

EXPLODED VIEW & PARTS LISTING

Air Operated Double Diaphragm Pump

Model: NDP-40BST
Model #: 852639 - NPT
Model #: 852225 - Flange



To Purchase:

- 800-990-7867
- sales@yamadapump.com
- Find My Rep

More Information:

- YouTube: @yamadapump
- yamadapump.com
- Data Sheets | CAD Drawings | Manuals Literature | BOM | Performance Curves

Trial Program

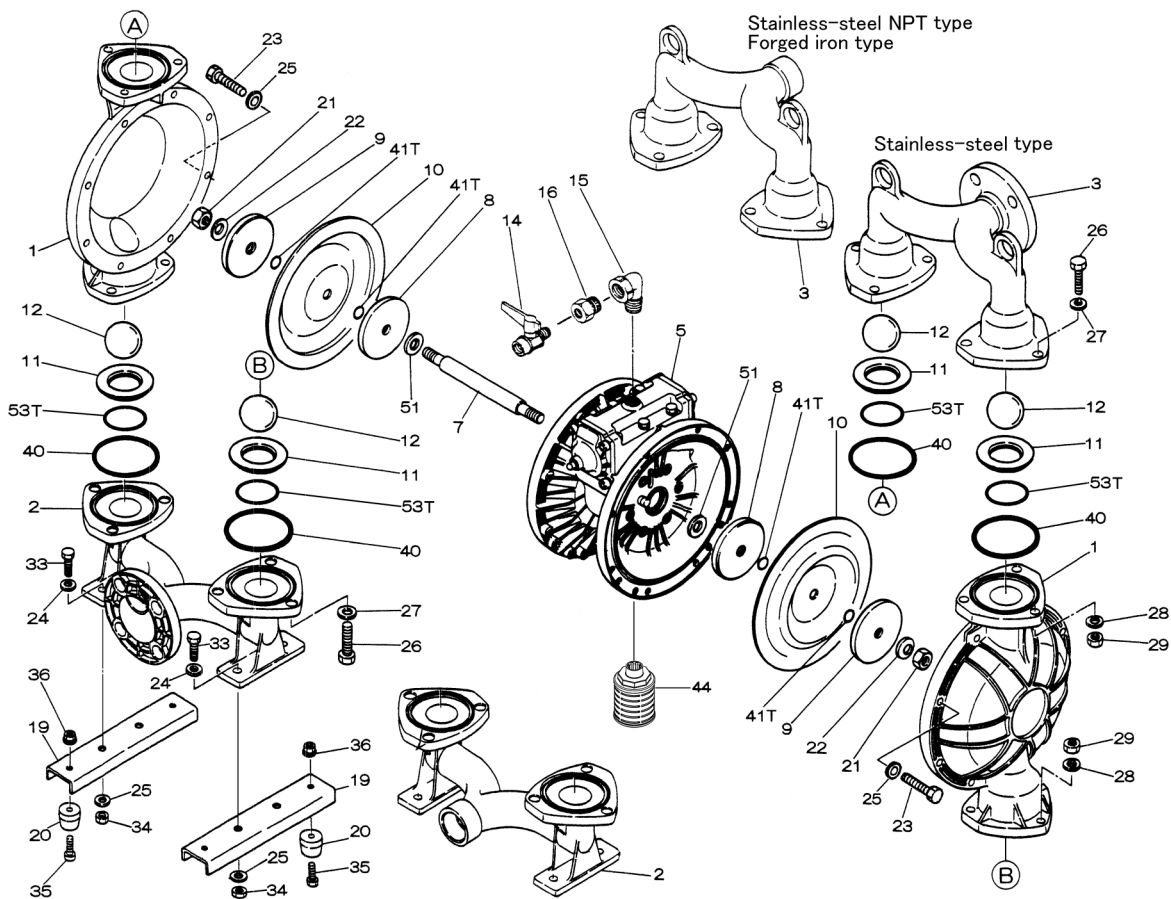

■ Body Assembly



■ Valve Body Assembly

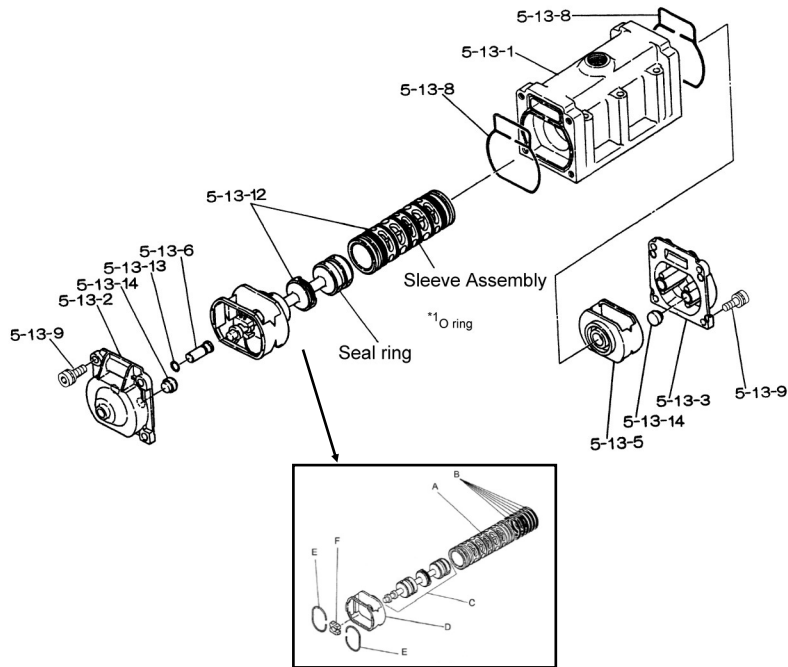

Air Operated Double Diaphragm Pump

REF. NO.	PART NO.	DESCRIPTION	QTY.	REORDER
1	712931	OUT CHAMBER 40SS	2	
2	712601	IN MANIFOLD 40SS NPT	1	
2	712599	IN MANIFOLD 40SS FLANGE	1	
3	712600	OUT MANIFOLD 40SS NPT	1	
3	712598	OUT MANIFOLD 40SS FLANGE	1	
5	803111	CENTER BODY ASSY.	1	
5- 1	711933	AIR CHAMBER 40	2	
5- 2	711936	BODY 40/50/80	1	
5- 3	772689	THROAT BEARING 40/50/80	2	
5- 4	711937	PILOT VALVE SPRING 40/50	2	
5- 5	771740	PILOT VALVE SEAT 40/50	2	
5- 6	832162	PILOT VALVE ASSY 40/50	2	
5- 8	640020	O-RING	2	
5- 9	685444	V-PACKING 40/50/80	2	
5-10	640029	O-RING	2	
5-11	771742	GASKET 40/50/80	2	
5-12	683812	M8X1.25X20 FLAT SOCKET	12	
5-13	802971	VALVE BODY ASSY.	1	
5-13- 1	711931	VALVE BODY 40/50/80	1	
5-13- 2	580999	CAP A 40/50/80	1	
5-13- 3	581000	CAP B 40/50/80	1	
5-13- 5	771735	SPRING RETAINER	1	
5-13- 6	712976	RESET BUTTON 40/50/80	1	
5-13- 8	771738	GASKET 40/50/80 SPOOL	2	
5-13- 9	685036	SOCKET BOLT W/ WASHER	8	
5-13-12	805084	C SPOOL ASSY 40/50/80	1	
A	803675	SLEEVE ASSY.	1	
B	640036	O-RING	6	
C	805085	SPOOL ASSY.	1	
D	771735	SPRING RETAINER	1	
E	711932	C-SPRING	2	
F	771734	BLOCK	1	
5-13-13	640005	O-RING	1	
5-13-14	684128	CUSHION 40/50/80 CAP	4	
5-14	771712	GASKET FOR VALVE BODY	1	
5-15	684240	BOLT W/WASHER	6	
5-18	684987	WASHER	12	
7	711939	CENTER ROD 40/50T	1	
8	707817	CENTER DISK 40T INNER	2	
9	707818	CENTER DISK 40SS-T OUT	2	
10	770814	DIAPHRAGM (PTFE) 40	2	
11	711908	VALVE SEAT 40SS	4	
12	770692	BALL 40T PTFE	4	
14	684321	BALL VALVE 1/2"	1	
15	682523	ELBOW STRT 3/4" 90D	1	
16	684339	BUSHING 40	1	
19	711911	BASE 40	2	
20	771402	FOOT RUBBER	4	
21	706128	NUT SS	2	

REF. NO.	PART NO.	DESCRIPTION	QTY.	REORDER
22	682740	WASHER M16 SS CONICAL	2	
23	621180	BOLT	16	
24	631174	FLAT WASHER	4	
25	631937	WAVE WASHER	20	
26	621202	BOLT	12	
27	631175	FLAT WASHER	12	
28	631938	WAVE WASHER	12	
29	628014	NUT	12	
33	621175	BOLT	4	
34	628013	NUT	4	
35	611149	BOLT	4	
36	682276	NUT W/FLANGE	4	
40	643065	O-RING	4	
41T	643015	O-RING	4	
44	804764	SILENCER ASSY	1	
53T	643136	O-RING	4	
KIT	K40-MT	LIQUID END KIT		
KIT	K45-AM	AIR MOTOR KIT		

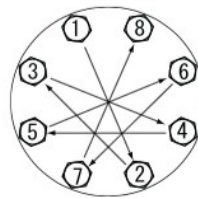

Tightening torque for center rod and out chambers.
 Center Rod 43 ft-lbf {60 N-m}
 Out Chambers 29 ft-lbf {40 N-m}

Tightening torque for manifold retainer bolts.
 40BST 18 ft-lbf {25 N-m}

General Tools:

- Socket wrenches - 13mm, 17mm, 19, mm 24mm
- Hexagonal box wrench - 5mm, 6mm
- Small crowbars - 2
- Open-end wrenches - 24mm
- Plastic hammer

Special Tools (sold separately):

- Sleeve remover (713180)

Miscellaneous:

- Assembly Oil - turbine oil none additional class 1 (equivalent to ISO VG32 grade)
- Nuts - M16 x 1.5
- Thread locker
- Urea grease grade (NLGI) No. 2

Customer Notes	
Model #:	_____
Description:	_____
Serial #:	_____
Date Installed:	_____
Department Location:	_____
Tag/Project:	_____