

To Purchase:

- ☎ 800-990-7867
- ✉ sales@yamadapump.com
- 📍 Find My Rep

More Information:

- ▶ YouTube: @yamadapump
- 🌐 yamadapump.com
- Data Sheets | CAD Drawings | Manuals Literature | BOM | Performance Curves*

Trial Program

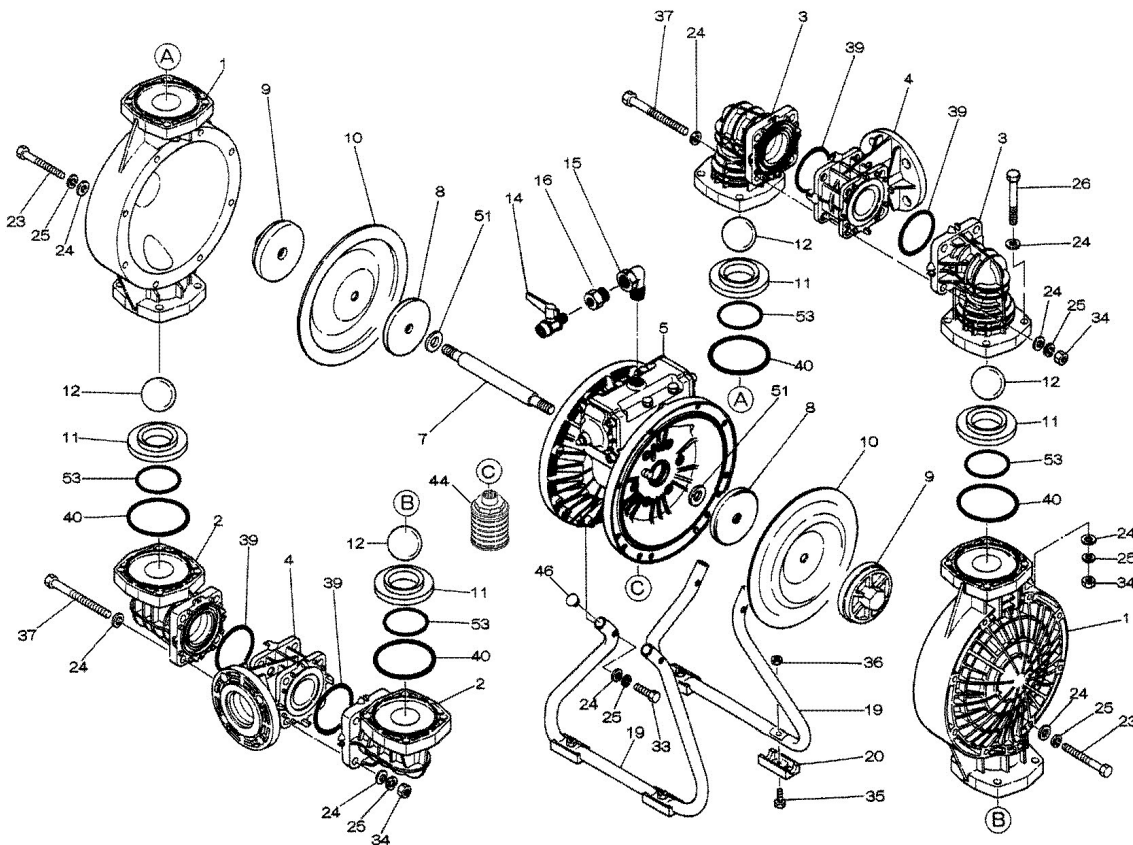

Air Operated Double Diaphragm Pump

■ Body Assembly

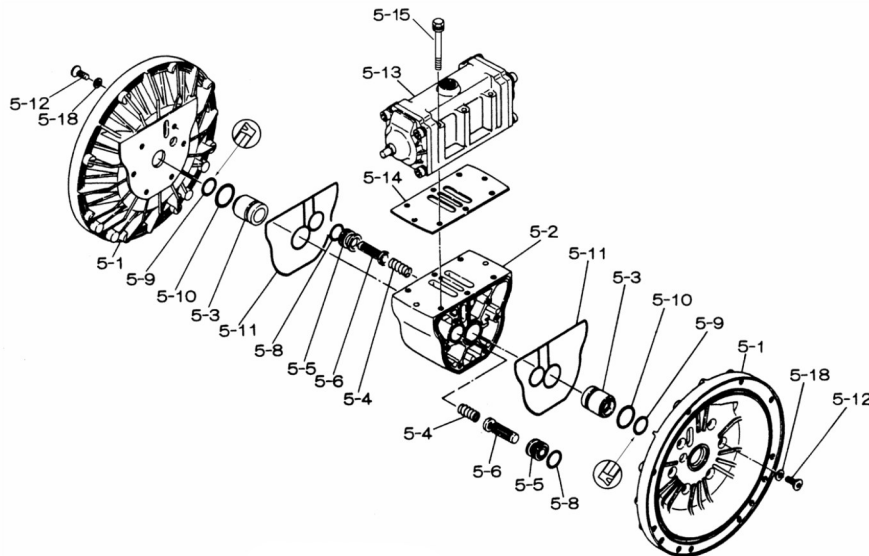

■ Valve Body Assembly

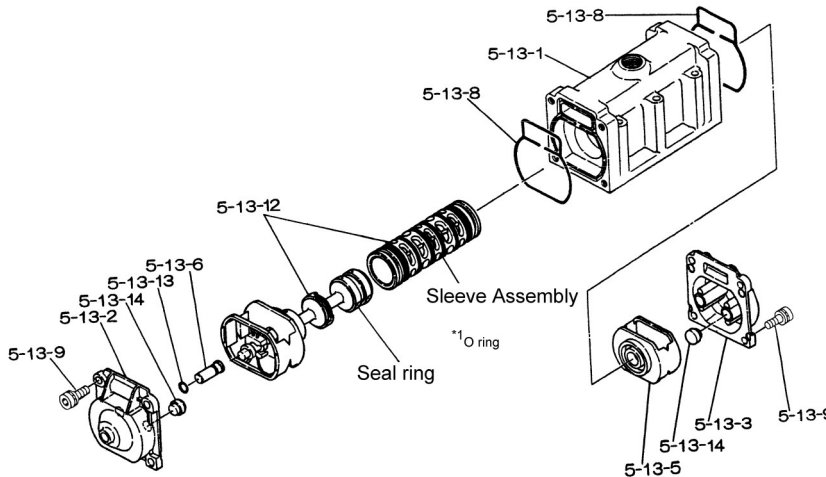

General Tools:

- Socket wrenches - 13mm, 17mm
- Hexagonal box wrench - 5mm
- Small crowbars - 2
- Open-end wrenches - 17mm

Special Tools:

- Wrench (771868) used to remove the center disc (sold separately).
- Sleeve remover (713148) used to remove sleeves (sold separately).

Miscellaneous:

- Assembly Oil - turbine oil none additional class 1 (equivalent to ISO VGA32 grade)
- Nuts - M16 x 1.5
- Thread locker
- Urea grease grade (NLGI) No. 2

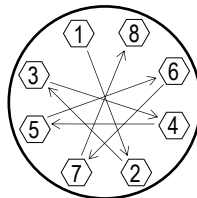

Tightening torque for center rod and out chambers.

Center Rod	36 ft-lbf {50 N-m}
Out Chambers	26 ft-lbf {35 N-m}

Tightening torque for manifold bolts.

BPC/N/E/H/S/V	15 ft-lbf {20 N-m}
---------------	--------------------

Air Operated Double Diaphragm Pump

	NDP-40BPC	NDP-40BPN	NDP-40BPE	NDP-40BPH	NDP-40BPS	NDP-40BPV			
	852421	852226	852422	852227	852711	852302			
REF. NO.	PART NO.	PART NO.	PART NO.	PART NO.	PART NO.	PART NO.	DESCRIPTION	QTY.	REORDER
1	780147	780147	780147	780147	780147	780147	OUT CHAMBER 40PP	2	
2	780244	780244	780244	780244	780244	780244	IN MANIFOLD 40PP	2	
3	780150	780150	780150	780150	780150	780150	OUT MANIFOLD 40PP-2	2	
4	780248	780248	780248	780248	780248	780248	CENTER MANIFOLD 40PP	2	
5	803111	803111	803111	803111	803111	803111	BODY ASSY	1	
5- 1	711933	711933	711933	711933	711933	711933	AIR CHAMBER	2	
5- 2	711936	711936	711936	711936	711936	711936	BODY 40/50/80	1	
5- 3	772689	772689	772689	772689	772689	772689	THROAT BEARING	2	
5- 4	711937	711937	711937	711937	711937	711937	PILOT VALVE SPRING	2	
5- 5	771740	771740	771740	771740	771740	771740	PILOT VALVE SEAT	2	
5- 6	832162	832162	832162	832162	832162	832162	PILOT VALVE ASSY	2	
5- 8	640020	640020	640020	640020	640020	640020	O-RING	2	
5- 9	685444	685444	685444	685444	685444	685444	V-PACKING	2	
5-10	640029	640029	640029	640029	640029	640029	O-RING	2	
5-11	771742	771742	771742	771742	771742	771742	GASKET	2	
5-12	683812	683812	683812	683812	683812	683812	M8X1.25X20 FLAT SOCKET	12	
5-13	802971	802971	802971	802971	802971	802971	VALVE BODY ASSY	1	
5-13- 1	711931	711931	711931	711931	711931	711931	VALVE BODY	1	
5-13- 2	580999	580999	580999	580999	580999	580999	CAP A	1	
5-13- 3	581000	581000	581000	581000	581000	581000	CAP B	1	
5-13- 5	771735	771735	771735	771735	771735	771735	SPRING RETAINER	1	
5-13- 6	712976	712976	712976	712976	712976	712976	RESET BUTTON	1	
5-13- 8	771738	771738	771738	771738	771738	771738	GASKET	2	
5-13- 9	685036	685036	685036	685036	685036	685036	SOCKET BOLT	8	
5-13-12	805084	805084	805084	805084	805084	805084	C SPOOL ASSY	1	
5-13-13	640005	640005	640005	640005	640005	640005	O-RING	1	
5-13-14	684128	684128	684128	684128	684128	684128	CUSHION	4	
5-14	771712	771712	771712	771712	771712	771712	GASKET FOR VALVE BODY	1	
5-15	684240	684240	684240	684240	684240	684240	BOLT W/ WASHERS M8X85	6	
5-18	684987	684987	684987	684987	684987	684987	WASHER	12	
7	711900	711900	711900	711900	711900	711900	CENTER ROD 40/50	1	
8	711902	711902	711902	711902	711902	711902	CENTER DISC 40-R	2	
9	771725	771725	771725	771725	771725	771725	CENTER DISC 40PP-R	2	
10	771853	771700	771854	771701	771975	771799	DIAPHRAGM	2	
11	772096	772096	772096	772096	772096	772096	VALVE SEAT 40PP-2	4	
12	770550	770584	770593	773142	773172	770602	BALL 40	4	
14	684321	684321	684321	684321	684321	684321	BALL VALVE 1/2	1	
15	682523	682523	682523	682523	682523	682523	ELBOW	1	
16	684339	684339	684339	684339	684339	684339	BUSHING 40	1	
19	711925	711925	711925	711925	711925	711925	STAND 40PP	2	
20	771865	771865	771865	771865	771865	771865	FOOT RUBBER	4	
23	686156	686156	686156	686156	686156	686156	BOLT	16	
24	631330	631330	631330	631330	631330	631330	WASHER FLAT M10 SS	68	
25	680257	680257	680257	680257	680257	680257	SPRING WASHER M10 SS	44	
26	621183	621183	621183	621183	621183	621183	BOLT	16	
33	621179	621179	621179	621179	621179	621179	BOLT	4	
34	628013	628013	628013	628013	628013	628013	NUT M10X1.5 CT SS	24	
35	621149	621149	621149	621149	621149	621149	BOLT	4	
36	683837	683837	683837	683837	683837	683837	NUT W/ FLANGE M8 X 1.2	4	
37	683542	683542	683542	683542	683542	683542	BOLT	8	
39	640060	640060	683998	640060	683998	642060	O-RING	4	
40	640064	640064	684121	640064	684121	642064	O-RING	4	
44	804764	804764	804764	804764	804764	804764	SILENCER ASSY	1	
46	683641	683641	683641	683641	683641	683641	CAP 40/50/80PP STAND	4	
51	770582	770582	770582	770582	770582	770582	CUSHION	2	
53	640136	640136	685447	640136	685447	642136	O-RING	4	
KIT	K40-PC	K40-PN	K40-PE	K40-PH	K40-PS	K40-PV	LIQUID END KIT		
KIT				K45-AM			AIR MOTOR KIT		

Customer Notes

Model #: _____
 Description: _____
 Serial #: _____
 Date Installed: _____
 Department Location: _____
 Tag/Project: _____