

EXPLODED VIEW & PARTS LISTING

Air Operated Double Diaphragm Pump

Model: NDP-20BP
Polypropylene Series

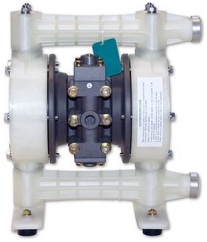

To Purchase:

- ☎ 800-990-7867
- ✉ sales@yamadapump.com
- 📍 Find My Rep

More Information:

- ▶ YouTube: @yamadapump
- 🌐 yamadapump.com
- Data Sheets | CAD Drawings | Manuals Literature | BOM | Performance Curves

Trial Program

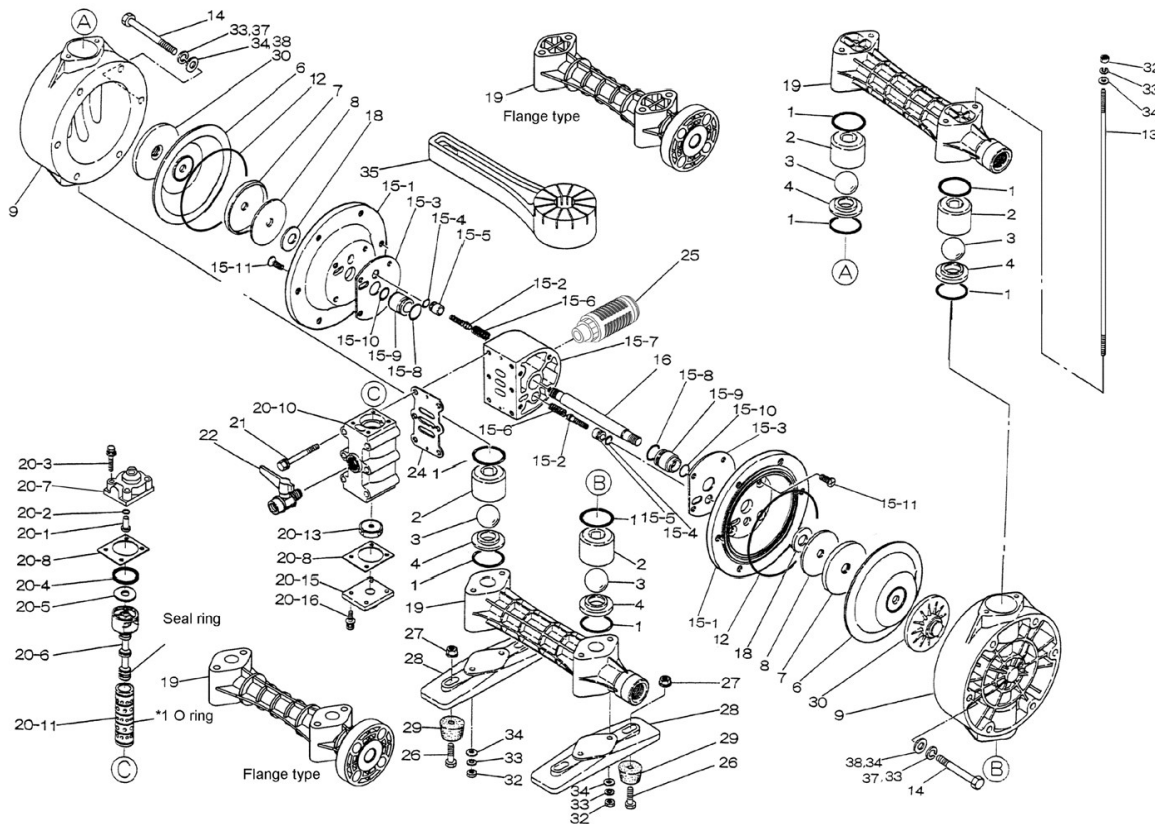

Air Operated Double Diaphragm Pump

| | NDP-20BPC | NDP-20BPE | NDP-20BPH | NDP-20BPN | NDP-20BPS | NDP-20BPV | | | |
|---------------|---------------|---------------|---------------|---------------|---------------|---------------|---------------------------|------|---------|
| NPT | 851665 | 852383 | 852069 | 852382 | 852695 | 852384 | ** NPT PUMPS ** | | |
| FLANGE | 853828 | 853830 | 853833 | 853829 | 853834 | 853831 | ** FLANGE PUMPS ** | | |
| REF. No. | PARTS No. | PARTS No. | PARTS No. | PARTS No. | PARTS No. | PARTS No. | DESCRIPTION | QTY. | REORDER |
| 1 | 640033 | 684116 | 640033 | 640033 | 684116 | 642033 | O-RING | 8 | |
| 2 | 771216 | 771216 | 771216 | 771216 | 771216 | 771216 | BALL GUIDE | 4 | |
| 3 | 770705 | 770723 | 773126 | 770720 | 773170 | 770726 | BALL | 4 | |
| 4 | 780137 | 780137 | 780137 | 780137 | 780137 | 780137 | VALVE SEAT | 4 | |
| 6 | 772957 | 772959 | 771362 | 772958 | 771973 | 772960 | DIAPHRAGM | 2 | |
| 7 | 709153 | 709153 | 716225 | 709153 | 716225 | 709153 | CENTER DISK | 2 | |
| 8 | 709152 | 709152 | 716226 | 709152 | 716226 | 709152 | WASHER | 2 | |
| 9 | 780134 | 780134 | 780134 | 780134 | 780134 | 780134 | OUT CHAMBER | 2 | |
| 12 | - | - | 640151 | - | 640151 | - | O-RING | 2 | |
| 13 | 710122 | 710122 | 710122 | 710122 | 710122 | 710122 | TIE ROD | 4 | |
| 14 | 621163 | 621163 | 621163 | 621163 | 621163 | 621163 | BOLT | 12 | |
| 15 | 804878 | 804878 | 804878 | 804878 | 804878 | 804878 | CENTER BODY ASSY. | 1 | |
| 15-1 | 715938 | 715938 | 715938 | 715938 | 715938 | 715938 | AIR CHAMBER | 2 | |
| 15-2 | 802360 | 802360 | 802360 | 802360 | 802360 | 802360 | PILOT VALVE ASSY. | 2 | |
| 15-2 seal | 771053 | 771053 | 771053 | 771053 | 771053 | 771053 | SEAL RING | 5 | |
| 15-3 | 771057 | 771057 | 771057 | 771057 | 771057 | 771057 | GASKET | 2 | |
| 15-4 | 640009 | 640009 | 640009 | 640009 | 640009 | 640009 | O-RING | 2 | |
| 15-5 | 771945 | 771945 | 771945 | 771945 | 771945 | 771945 | PILOT VALVE SEAT | 2 | |
| 15-6 | 708666 | 708666 | 708666 | 708666 | 708666 | 708666 | SPRING | 2 | |
| 15-7 | 711503 | 711503 | 711503 | 711503 | 711503 | 711503 | BODY | 1 | |
| 15-8 | 685276 | 685276 | 685276 | 685276 | 685276 | 685276 | O-RING | 2 | |
| 15-9 | 772703 | 772703 | 772703 | 772703 | 772703 | 772703 | THROAT BEARING | 2 | |
| 15-10 | 685414 | 685414 | 685414 | 685414 | 685414 | 685414 | V-PACKING | 2 | |
| 15-11 | 682486 | 682486 | 682486 | 682486 | 682486 | 682486 | BOLT | 8 | |
| 16 | 710252 | 710252 | 710252 | 710252 | 710252 | 710252 | CENTER ROD | 1 | |
| 18 | 771054 | 771054 | 771054 | 771054 | 771054 | 771054 | CUSHION | 2 | |
| 19 | 780010 | 780010 | 780010 | 780010 | 780010 | 780010 | MANIFOLD (NPT) | 2 | |
| 19 | 780208 | 780208 | 780208 | 780208 | 780208 | 780208 | MANIFOLD (FLANGE) | 2 | |
| 20 | 802809 | 802809 | 802809 | 802809 | 802809 | 802809 | AIR VALVE ASSY. | 1 | |
| 20-1 | 709161 | 709161 | 709161 | 709161 | 709161 | 709161 | RESET BUTTON | 1 | |
| 20-2 | 640005 | 640005 | 640005 | 640005 | 640005 | 640005 | O-RING | 1 | |
| 20-3 | 682704 | 682704 | 682704 | 682704 | 682704 | 682704 | BOLT | 4 | |
| 20-4 | 771241 | 771241 | 771241 | 771241 | 771241 | 771241 | PACKING | 1 | |
| 20-5 | 715961 | 715961 | 715961 | 715961 | 715961 | 715961 | WASHER | 1 | |
| 20-6 | 802400 | 802400 | 802400 | 802400 | 802400 | 802400 | C-SPOOL ASSY. | 1 | |
| 20-7 | 711219 | 711219 | 711219 | 711219 | 711219 | 711219 | CAP A | 1 | |
| 20-8 | 771240 | 771240 | 771240 | 771240 | 771240 | 771240 | GASKET | 2 | |
| 20-10 | 711640 | 711640 | 711640 | 711640 | 711640 | 711640 | VALVE BODY | 1 | |
| 20-11 | 803931 | 803931 | 803931 | 803931 | 803931 | 803931 | SLEEVE ASSY. | 1 | |
| 20-11-*1 | 771080 | 771080 | 771080 | 771080 | 771080 | 771080 | O-RING | 6 | |
| 20-13 | 771914 | 771914 | 771914 | 771914 | 771914 | 771914 | CUSHION | 1 | |
| 20-15 | 711212 | 711212 | 711212 | 711212 | 711212 | 711212 | CAP B | 1 | |
| 20-16 | 682262 | 682262 | 682262 | 682262 | 682262 | 682262 | BOLT | 4 | |
| 21 | 682265 | 682265 | 682265 | 682265 | 682265 | 682265 | BOT | 6 | |
| 22 | 686019 | 686019 | 686019 | 686019 | 686019 | 686019 | BALL VALVE | 1 | |
| 25 | 771056 | 771056 | 771056 | 771056 | 771056 | 771056 | GASKET | 1 | |
| 25 | 804697 | 804697 | 804697 | 804697 | 804697 | 804697 | MUFFLER | 1 | |
| 26 | 611151 | 611151 | 611151 | 611151 | 611151 | 611151 | BOLT | 4 | |
| 27 | 682276 | 682276 | 682276 | 682276 | 682276 | 682276 | NUT W/FLANGE | 4 | |
| 28 | 771219 | 771219 | 771219 | 771219 | 771219 | 771219 | BASE | 2 | |
| 29 | 770551 | 770551 | 770551 | 770551 | 770551 | 770551 | FOOT RUBBER | 4 | |
| 30 | 780123 | 780123 | 780123 | 780123 | 780123 | 780123 | CENTER DISK | 2 | |
| 32 | 683635 | 683635 | 683635 | 683635 | 683635 | 683635 | NUT | 8 | |
| 33 | 681300 | 681300 | 681300 | 681300 | 681300 | 681300 | SPRING WASHER | 20 | |
| 34 | 631329 | 631329 | 631329 | 631329 | 631329 | 631329 | FLAT WASHER | 20 | |
| 35 | 771244 | 771244 | 771244 | 771244 | 771244 | 771244 | TOOL | 2 | |
| KIT | K20-PC | K20-PE | K20-PH | K20-PN | K20-PS | K20-PV | LIQUID SIDE | | |
| KIT | K225-AM | | | | | | AIR MOTOR | | |

Air Operated Double Diaphragm Pump

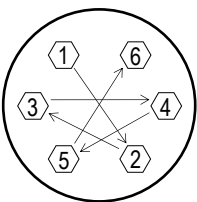

Tightening torque for center rod and out chambers.

| | |
|----------------------|--------------------|
| Center Rod | 29 ft-lbf {40 N-m} |
| Out Chambers C/N/E/V | 8 ft-lbf {10 N-m} |
| Out Chambers H/S | 10 ft-lbf {13 N-m} |

Tightening torque for manifold retainer bolts.
BPC/E/H/N/S/V 8 ft-lbf {10 N-m}

General Tools:

- Socket wrenches - 10mm, 12mm, 13mm, 17mm, 22mm
- Hexagonal box wrench - 5mm
- Open-end wrenches - 13mm

Special Tools:

- Disc remover (771244) used for removing the center disk
- Sleeve remover (713148) used for removing the sleeve.

Miscellaneous:

- Assembly Oil - turbine oil none additional class 1 (equivalent to ISA VGA32 grade)
- Nuts - M14 x 1.5
- Urea grease grade (NLGI) No. 2
- Lubricants equivalent to (Loctite Anti-Seize 767)

| Customer Notes | |
|-----------------------|-------|
| Model #: | _____ |
| Description: | _____ |
| Serial #: | _____ |
| Date Installed: | _____ |
| Department Location: | _____ |
| Tag/Project: | _____ |