

WEINMAN®

INSTALLATION and OPERATION MANUAL Submersible Sewage Ejector

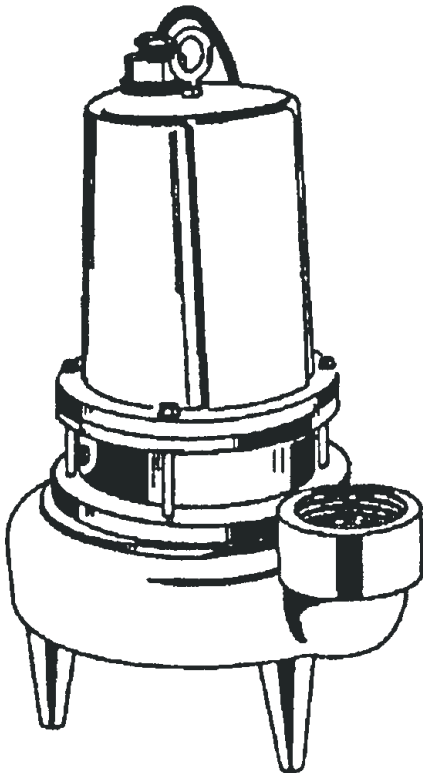

**Series: 3WE-DS, 1.5 & 2HP
1750RPM, 60Hz**

(Double Seal)

IMPORTANT!

*Read all instructions in this manual before operating pump.
As a result of Crane Pumps & Systems, Inc., constant product improvement program,
product changes may occur. As such Crane Pumps & Systems reserves the right to
change product without prior written notification.*

CRANE[®]

A Crane Co. Company

PUMPS & SYSTEMS

420 Third Street
Piqua, Ohio 45356
Phone: (937) 778-8947
Fax: (937) 773-7157
www.cranepumps.com

83 West Drive, Bramton
Ontario, Canada L6T 2J6
Phone: (905) 457-6223
Fax: (905) 457-2650



Form No. 093642-Rev. J

TABLE OF CONTENTS

SAFETY FIRST	3
A. PUMP SPECIFICATIONS	4
B. GENERAL INFORMATION	5
C. INSTALLATION	5 - 6
ELECTRICAL DATA	7
D. START-UP OPERATION	6
E. PREVENTATIVE MAINTENANCE	7
F. SERVICE and REPAIR	7 - 11
G. REPLACEMENT PARTS.....	11
TRUBLE SHOOTING	12
CROSS-SECTION (Fig. 8).....	13
EXPLODED VIEW (Fig. 9).....	14
PARTS LIST	15 - 16
RETURNED GOODS POLICY.....	17
WARRANTY	18
START-UP REPORT	19 - 20
WARRANTY REGISTRATION	
SPECIAL TOOLS AND EQUIPMENT	
INSULATION TESTER (MEGGER)	
DIELECTRIC TESTER	
SEAL TOOL KIT (see parts list)	
PRESSURE GAUGE KIT (see parts list)	

SAFETY FIRST!

Please Read This Before Installing Or Operating Pump.
This information is provided for **SAFETY and to PREVENT EQUIPMENT PROBLEMS**. To help recognize this information, observe the following symbols:



IMPORTANT! Warns about hazards that can result in personal injury or Indicates factors concerned with assembly, installation, operation, or maintenance which could result in damage to the machine or equipment if ignored.

CAUTION ! Warns about hazards that can or will cause minor personal injury or property damage if ignored. Used with symbols below.

WARNING ! Warns about hazards that can or will cause serious personal injury, death, or major property damage if ignored. Used with symbols below.



Hazardous fluids can cause fire or explosions, burnes or death could result.



Extremely hot - Severe burnes can occur on contact.



Biohazard can cause serious personal injury.



Hazardous fluids can Hazardous pressure, eruptions or explosions could cause personal injury or property damage.



Rotating machinery Amputation or severe laceration can result.



Hazardous voltage can shock, burn or cause death.

Only qualified personnel should install, operate and repair pump. Any wiring of pumps should be performed by a qualified electrician.



WARNING ! - To reduce risk of electrical shock, pumps and control panels must be properly grounded in accordance with the National Electric Code (NEC) or the Canadian Electrical Code (CEC) and all applicable state, province, local codes and ordinances.



WARNING! - To reduce risk of electrical shock, always disconnect the pump from the power source before handling or servicing. Lock out power and tag.



WARNING! Operation against a closed discharge valve will cause premature bearing and seal failure on any pump, and on end suction and self priming pump the heat build may cause the generation of steam with resulting dangerous pressures. It is recommended that a high case temperature switch or pressure relief valve be installed on the pump body.



CAUTION ! Never operate a pump with a plug-in type power cord without a ground fault circuit interrupter.



CAUTION! Pumps build up heat and pressure during operation-allow time for pumps to cool before handling or servicing.



WARNING! - **DO NOT** pump hazardous materials (flammable, caustic, etc.) unless the pump is specifically designed and designated to handle them.



Do not block or restrict discharge hose, as discharge hose may whip under pressure.



WARNING! - DO NOT wear loose clothing that may become entangled in the impeller or other moving parts.



WARNING! - Keep clear of suction and discharge openings. **DO NOT** insert fingers in pump with power connected.



Always wear eye protection when working on pumps.



Make sure lifting handles are securely fastened each time before lifting. **DO NOT** operate pump without safety devices in place. Always replace safety devices that have been removed during service or repair. Secure the pump in its operating position so it can not tip over, fall or slide.



DO NOT exceed manufacturers recommendation for maximum performance, as this could cause the motor to overheat.



DO NOT remove cord and strain relief. Do not connect conduit to pump.



WARNING! Cable should be protected at all times to avoid punctures, cut, bruises and abrasions - inspect frequently. Never handle connected power cords with wet hands.



WARNING! To reduce risk of electrical shock, all wiring and junction connections should be made per the NEC or CEC and applicable state or province and local codes. Requirements may vary depending on usage and location.



WARNING! Submersible Pumps are not approved for use in swimming pools, recreational water installations, decorative fountains or any installation where human contact with the pumped fluid is common.



WARNING! Products Returned Must Be Cleaned, Sanitized, Or Decontaminated As Necessary Prior To Shipment, To Insure That Employees Will Not Be Exposed To Health Hazards In Handling Said Material. All Applicable Laws And Regulations Shall Apply.



Bronze/brass and bronze/brass fitted pumps may contain lead levels higher than considered safe for potable water systems. Lead is known to cause cancer and birth defects or other reproductive harm. Various government agencies have determined that leaded copper alloys should not be used in potable water applications. For non-leaded copper alloy materials of construction, please contact factory.



IMPORTANT! - Crane Pumps & Systems, Inc. is not responsible for losses, injury, or death resulting from a failure to observe these safety precautions, misuse or abuse of pumps or equipment.

SECTION: A - PUMP SPECIFICATIONS:

DISCHARGE 3" NPT, Vertical
LIQUID TEMPERATURE . 104°F (40°C) Continuous
MOTOR HOUSING Cast Iron ASTM A-48, Class 30
VOLUTE Cast Iron ASTM A-48, Class 30
SEAL PLATE Cast Iron ASTM A-48, Class 30
IMPELLER:
Design 2 Vane, Open with Pump out vanes on Back side. Dynamically balanced, ISO G6.3
Material Cast Iron ASTM A-48, Class 30
SHAFT 416 Stainless Steel
SQUARE RINGS Buna-N
HARDWARE 300 Series Stainless Steel
PAINT Air dry enamel, top coat
SEAL *Design* Tandem Mechanical in oil filled reservoir
Material Rotating Faces - Carbon
 Stationary Faces - Ceramic
 Elastomer - Buna-N
 Hardware - 300 series stainless steel
CORD ENTRY 25 Ft. (7.6m) Cord, pressure grommet for sealing and strain relief
SPEED 1750RPM, 60Hz (nominal)

UPPER BEARING:
Design Single Row, Ball, Oil Lubricated
Load Radial
LOWER BEARING:
Design Single Row, Ball, Oil Lubricated
Load Radial & Thrust
MOTOR: *Design* NEMA L, Single phase, NEMA B, Three Phase Torque Curve, Oil Filled, Squirrel Cage Induction
Insulation Class B
SINGLE PHASE Permanent Split Capacitor (PSC) includes overload protection in motor
THREE PHASE 200-230/460, 60Hz is Tri voltage motor. Requires overload protection to be included in control panel
MOISTURE SENSOR N/O, Requires relay in control panel
TEMP. SENSOR N/C, Requires relay in control panel
OPTIONAL EQUIPMENT.. Seal Material, Impeller Trims, Additional Cord

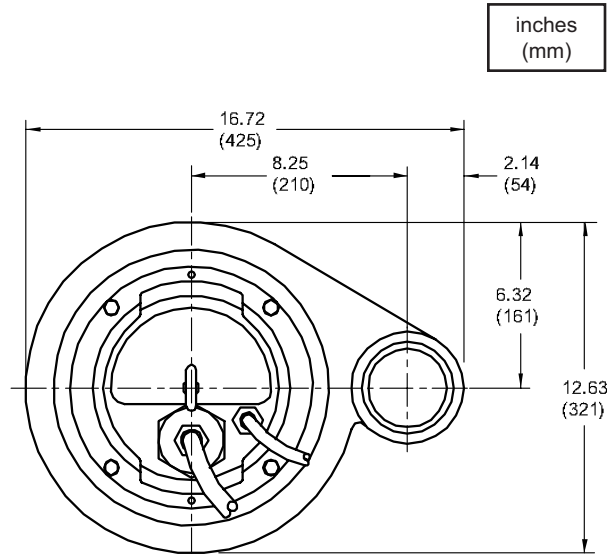
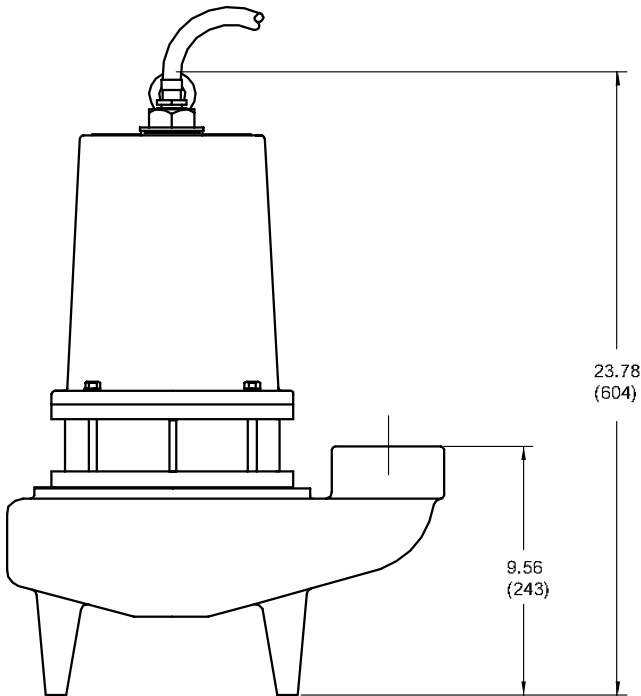

IMPORTANT !

- 1.) PUMP MAY BE OPERATED "DRY" FOR EXTENDED PERIODS WITHOUT DAMAGE TO MOTOR AND/OR SEALS.
- 2.) THIS PUMP IS APPROPRIATE FOR THOSE APPLICATIONS SPECIFIED AS CLASS I DIVISION II HAZARDOUS LOCATIONS.
- 3.) THIS PUMP IS NOT APPROPRIATE FOR THOSE APPLICATIONS SPECIFIED AS CLASS I DIVISION I HAZARDOUS LOCATIONS.
- 4.) INSTALLATIONS SUCH AS DECORATIVE FOUNTAINS OR WATER FEATURES PROVIDED FOR VISUAL ENJOYMENT MUST BE INSTALLED IN ACCORDANCE WITH THE NATIONAL ELECTRIC CODE ANSI/NFPA 70 AND/OR THE AUTHORITY HAVING JURISDICTION. THIS PUMP IS NOT INTENDED FOR USE IN SWIMMING POOLS, RECREATIONAL WATER PARKS, OR INSTALLATIONS IN WHICH HUMAN CONTACT WITH PUMPED MEDIA IS A COMMON OCCURRENCE.

SECTION B: GENERAL INFORMATION

B-1) To the Purchaser:

Congratulations! You are the owner of one of the finest pumps on the market today. CP&S pumps are products engineered and manufactured of high quality components. Over one hundred years of pump building experience along with a continuing quality assurance program combine to produce a pump which will stand up to the toughest applications. This manual will provide helpful information concerning installation, maintenance, and proper service guidelines.

B-2) Receiving:

Upon receiving the pump, it should be inspected for damage or shortages. If damage has occurred, file a claim immediately with the company that delivered the pump. If the manual is removed from the packaging, do not lose or misplace.

B-3) Storage:

Short Term- CP&S Pumps are manufactured for efficient performance following short inoperative periods in storage. For best results, pumps can be retained in storage, as factory assembled, in a dry atmosphere with constant temperatures for up to six (6) months.

Long Term- Any length of time exceeding six (6) months, but not more than twenty-four (24) months. The unit should be stored in a temperature controlled area, a roofed over walled enclosure that provides protection from the elements (rain, snow, wind-blown dust, etc.), and whose temperature can be maintained between +40 deg. F and +120 deg. F. (4.4 - 49°C). Pump should be stored in its original shipping container. On initial start up, rotate impeller by hand to assure seal and impeller rotate freely. If it is required that the pump be installed and tested before the long term storage begins, such installation will be allowed provided:

- 1.) The pump is not installed under water for more than one (1) month.
- 2.) Immediately upon satisfactory completion of the test, the pump is removed, thoroughly dried, repacked in the original shipping container, and placed in a temperature controlled storage area.

B-4) Service Centers:

For the location of the nearest Weinman Service Center, check your Weinman representative or Crane Pumps & Systems, Inc., Service Department in Piqua, Ohio, telephone (937) 778-8947 or Crane Pumps & Systems Canada, in Brampton, Ontario, (905) 457-6223.

SECTION C: INSTALLATION

C-1) Location:

These pumping units are self-contained and are recommended for use in a sump, lift station or basin. This pump is designed to pump sewage, effluent, or other nonexplosive or noncorrosive wastewater and shall NOT be installed in locations classified as hazardous in accordance with the National Electrical Code (NEC), ANSI/NFPA 70 or Canadian Electrical Code. Never install the pump in a trench, ditch or hole with a dirt bottom; the legs will sink into the dirt and the suction will become plugged.

C-1.1 Submergence:

It is recommended that the pump be operated in the submerged condition and the sump liquid level should never be less than dimension "A" in Figure 1.

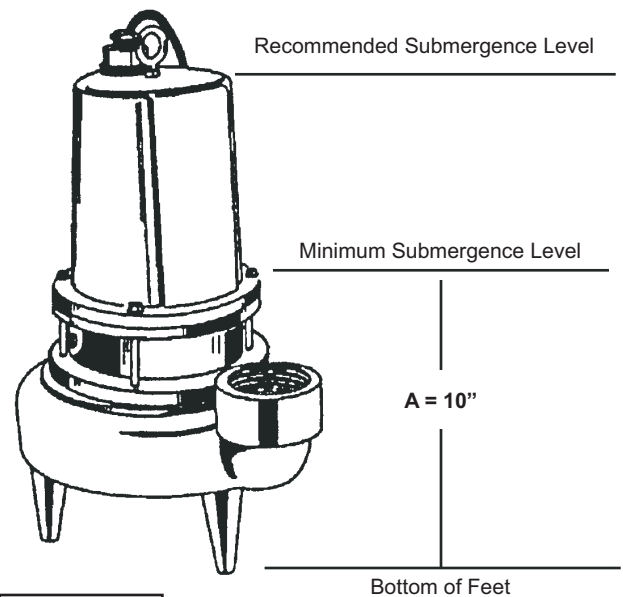

FIGURE 1

C-2) Discharge:

Discharge piping should be as short as possible. Both a check valve and a shut-off valve are recommended for each pump being used. The check valve is used to prevent backflow into the sump. Excessive backflow can cause flooding and/or damage to the pump. The shut-off valve is used to stop system flow during pump or check valve servicing.

Weinman supplies a breakaway fitting discharge system designed to allow the submersible wastewater pump to be installed or removed without requiring personnel to enter the wet well.

Place the Break Away Fitting (BAF) in position. Temporarily secure the guide rails in the upper mounting brackets and locate the base on the bottom of the wet well. Level the base with grout and/or shims. Install the intermediate support brackets, if required. Make sure the rails are in a true vertical position so the pump will clear the access opening and will slide freely down the rails into place on the discharge stationary fitting. Once the rails are in proper alignment, bolt the base into the floor of the station and connect the discharge pipe to the elbow. Connect the movable portion and other supplied fittings of the BAF onto the pump and lower into wet well. See the Break Away Fitting manual for more information.

C-3) Liquid Level Controls:

The level controls are to be supported by a mounting bracket that is attached to the sump wall, cover or junction box. Cord grips are used to hold the cords in place on the mounting bracket. The control level can be changed by loosening the grip and adjusting the cord length as per the plans and specifications. Be certain that the level controls cannot hang up or foul in it's swing and that the pump is completely submerged when the level control is in the "Off" mode.

C-4) Electrical Connections:

C-4.1) Power & Control Cords:

The cord assembly mounted to the pump must not be modified in any way except for shortening to a specific application. Any splice between the pump and the control panel must be made in accordance with all applicable electric codes. It is recommended that a junction box, if used, be mounted outside the sump or be of at least Nema 4 (EEMAC-4) construction if located within the wet well. **DO NOT USE THE POWER OR CONTROL CORDS TO LIFT PUMP.**

NOTE: The White Wire Is Not A Neutral Or Ground Lead. The Black, White And Red Leads Are Power Carrying Conductors. The Green Lead Is For Connection To Ground.

C-4.2) Overload Protection :

C-4.2-1) Three Phase - The normally closed (N/C) thermal sensor is embedded in the motor windings and will detect excessive heat in the event an overload condition occurs. The thermal sensor will trip when the windings become too hot and will automatically reset itself when the pump motor cools to a safe temperature. It is recommended that the thermal sensor be connected in series to an alarm device to alert the operator of an overload condition, and/or the motor starter coil to stop the pump. In the event of an overload, the source of this condition should be determined and rectified immediately. **DO NOT LET THE PUMP CYCLE OR RUN IF AN OVERLOAD CONDITION OCCURS !**

C-4.2-2) Single Phase - The type of in-winding overload protector used is referred to as an inherent overheating protector and operates on the combined effect of temperature and current. This means that the overload protector will trip out and shut the pump off if the windings become too hot, or the load current passing through them becomes too high. It will then automatically reset and start the pump up after the motor cools to a safe temperature. In the event of an overload, the source of this condition should be determined and rectified immediately. **DO NOT LET THE PUMP CYCLE OR RUN IF AN OVERLOAD CONDITION OCCURS !**

NOTE: Single phase pumps can be ordered with an optional Thermal Sensor as well as the standard in winding overload protection.

C-4.3) Moisture Sensors:

A normally open (N/O) detector is installed in the pump seal chamber which will detect any moisture present. It is recommended that this detector be connected in series to an alarm device or the motor starter coil to alert the operator that a moisture detect has occurred. In the event of a moisture detect, check the individual moisture sensor probe leads for continuity, (∞ resistance = no moisture) and the junction box/control box for moisture content. The above situations may induce a false signal in the moisture detecting circuit. If none of the above test prove conclusive, the pump(s) should be pulled and the source of the failure identified and repaired. **IF A MOISTURE DETECT HAS OCCURRED SCHEDULE MAINTENANCE AS SOON AS POSSIBLE.**

TEMPERATURE SENSOR ELECTRICAL RATINGS		
Volts	Continuous Amperes	Inrush Amperes
110-120	3.00	30.0
220-240	1.50	15.0
440-480	0.75	7.5
600	0.60	6.0

C-4.4) Wire Size:

Consult a qualified electrician for proper wire size if additional power cable is required. See table for electrical information.

SECTION: D START-UP OPERATION

D-1) Check Voltage and Phase:

Before operating pump, compare the voltage and phase information stamped on the pump identification plate to the available power.

D-2) Check Pump Rotation:

Before putting pump into service for the first time, the motor rotation must be checked. Improper motor rotation can result in poor pump performance and can damage the motor and/or pump. To check the rotation, suspend the pump freely, momentarily apply power and observe the "kickback". "Kickback" should always be in a counter-clockwise direction as viewed from the top of the pump motor housing.

D-2.1) Incorrect Rotation for Three-Phase Pumps:

In the event that the rotation is incorrect for a three-phase installation, interchange any two power cable leads at the control box. **DO NOT** change leads in the cable housing in the motor. Recheck the "kickback" rotation again by momentarily applying power.

D-2.2) Incorrect Rotation for Single-Phase Pumps:

In the unlikely event that the rotation is incorrect for a single phase pump, contact a Weinman Service Center.

D-3) Start-Up Report:

Included at the end of this manual is a start-up report sheet, this sheet is to be completed as applicable. Return one copy to Weinman and store the second in the control panel or with the pump manual if no control panel is used. It is important to record this data at initial start-up since it will be useful to refer to should servicing the pump be required in the future.

D-3.1) Identification Plate:

Record the numbers from the pump identification plate on both START-UP REPORTS provided at the end of the manual for future reference.

D-3.2) Insulation Test:

Before the pump is put into service, an insulation (megger) test should be performed on the motor. The resistance values (ohms) as well as the voltage (volts) and current (amps) should be recorded on the start-up report.

D-3.3) Pump-Down Test:

After the pump has been properly wired and lowered into the basin, sump or lift station, it is advisable to check the system by filling with liquid and allowing the pump to operate through its pumping cycle. The time needed to empty the system, or pump-down time along with the volume of water, should be recorded on the start-up report.

MODEL NO	HP	VOLT/PH	Hz	RPM (Nom)	NEMA START CODE	FULL LOAD AMPS	LOCKED ROTOR AMPS	CORD SIZE	CORD TYPE	CORD O.D inch (mm)	WINDING RESISTANCE	
											EMERSON MAIN-START	G.E. MAIN-START
3WE1524DS	1.5	240/1	60	1750	C	16.0	44.6	10/3	SOW	0.690 (17.5)	1.21-2.80	---
3WE1594DS	1.5	200-240/3	60	1750	D/G	13.3/11.6	35.8/41.2	10/4	SOW	0.750 (19.1)	2.21	2.23
3WE1544DS	1.5	480/3	60	1750	G	5.8	20.6	10/4	SOW	0.750 (19.1)	8.84	8.92
3WE1554DS	1.5	600/3	60	1750	G	4.6	16.4	10/4	SOW	0.750 (19.1)	13.79	13.95
3WE2024DS	2.0	240/1	60	1750	A	19.0	44.6	10/3	SOW	0.690 (17.5)	1.21-2.80	---
3WE2094DS	2.0	200-240/3	60	1750	B/D	15.2/13.2	35.8/41.2	10/4	SOW	0.750 (19.1)	2.21	2.23
3WE2044DS	2.0	480/3	60	1750	D	6.6	20.6	10/4	SOW	0.750 (19.1)	8.84	8.92
3WE2054DS	2.0	600/3	60	1750	D	5.2	16.4	10/4	SOW	0.750 (19.1)	13.79	13.95

Winding Resistance \pm 5%, measured from terminal block. Pump rated for operation at \pm 10% voltage at motor
Moisture & Temperature sensor cord for all models is 18/5 SOW, 0.470 (11.9mm) O.D.
OPTIONAL - Temperature sensor cord for 3 phase models is 14/2 SOW, 0.530 (13.5mm) O.D.

SECTION E: PREVENTATIVE MAINTENANCE

As the motor is oil filled, no lubrication or other maintenance is required, and generally Weinman pumps will give very reliable service and can be expected to operate for years on normal sewage pumping without failing. However as with any mechanical piece of equipment a preventive maintenance program is recommended and suggested to include the following checks:

- 1) Inspect motor and seal chamber for oil level and contamination and repair as required per section F-1.
- 2) Inspect impeller and body for excessive build-up or clogging and repair as required per section F-2.
- 3) Inspect motor and bearings and replace as required per section F-3.
- 4) Inspect seal for wear or leakage and repair as required per section F-4.

SECTION F: SERVICE AND REPAIR

NOTE: All item numbers in () refer to Figures 8 & 9.

F-1) Lubrication:

Anytime the pump is removed from operation, the cooling oil in the motor housing (5) should be checked visually for oil level and contamination.

F-1.1) Checking Oil:

Motor Housing- To check oil, set unit upright. Remove gland nut (30a) see Fig. 5, from hex nut (16). Unscrew hex nut (16) from motor housing (5). **DO NOT** disconnect wiring from motor leads. With a flashlight, visually inspect the oil in the motor housing (5) to make sure it is clean and clear, light amber in color and free from suspended particles. Milky white oil indicates the presence of water. Oil level should be to bottom of plug (19) Fig. 9, when pump is in vertical position.

F-1.2) Testing Oil:

1. Place pump on it's side, remove pipe plug (19), from motor housing (5) and drain oil into a clean, dry container.
2. Check oil for contamination using an oil tester with a range to 30 Kilovolts breakdown.
3. If oil is found to be clean and uncontaminated (measure above 15 KV. breakdown), refill the motor housing as per section F-1.3.

4. If oil is found to be dirty or contaminated (or measures below 15 KV. breakdown), the the pump must be carefully inspected for leaks at the shaft seals (31), cable assemblies (30) and (32), and hex nut (16), O-rings (8) and pipe plugs (19), before refilling with oil. To locate the leak, perform a pressure test as per section F-1.4. After leak is repaired, refill with new oil as per section F-1.3.



Important ! - DO NOT overfill oil. Overfilling of motor housing with oil can create excessive and dangerous hydraulic pressure which can destroy the pump and create a hazard. Overfilling oil voids warranty.

F-1.3) Replacing Oil:

Motor Housing - Drain all oil from motor housing and dispose of properly. Set unit upright and refill with (see parts list for amount) new cooling oil as per Table 1. Fill to pipe plug (19), on motor housing (5), level as an air space must remain in the top of the motor housing to compensate for oil expansion (see Fig. 9). Apply pipe thread compound to threads of hex nut (16) and pipe plug (19) then assemble to motor housing (5). Insert friction ring (30b), grommet (30c), another friction ring (30b), and gland nut (30a) into hex nut (16) and torque to 15 ft. lbs.

Seal Chamber - Set unit on its side with fill plug (19) downward, remove plug (19) and drain all oil from seal chamber. Set unit on its side, with plug (19) upward, and refill completely with (see parts list for amount) new oil as per Table 1. Apply pipe thread compound to threads of pipe plug (19) and assemble to spacer (50).

TABLE 1 - COOLING OIL - Dielectric	
SUPPLIER	GRADE
BP	Enerpar SE100
Conoco	Pale Paraffin 22
Mobile	D.T.E. Oil Light
G & G Oil	Circulating 22
Imperial Oil	Voltesso-35
Shell Canada	Transformer-10
Texaco	Diala-Oil-AX
Woco	Premium 100

F-1.4) Pressure Test:

Motor Housing - Before checking the pump for leaks around the shaft seal, square rings, and cord inlet, the oil level should be full as described in section F-1.3. Remove pipe plug (19) from motor housing (5). Apply pipe sealant to pressure gauge assembly and tighten into hole (see Fig. 2). Pressurize motor housing to 10 P.S.I. Use a soap solution around the sealed areas and inspect joints for "air bubbles". If, after five minutes, the pressure is still holding constant, and no "bubbles" are observed, slowly bleed the pressure and remove the gauge assembly. Replace the pipe plug (19) using a sealant. If the pressure does not hold, then the leak must be located and repaired.

Seal Chamber - Remove pipe plug (19) from spacer (50) and check that the seal chamber is full of oil. Apply pipe sealant to pressure gauge assembly and tighten into hole in spacer (50). Pressurize seal chamber to 10 P.S.I. and check for leaks as outlined above.



Caution ! - Pressure builds up extremely fast, increase pressure by "tapping" air nozzle. Too much pressure will damage seal. DO NOT exceed 10 P.S.I.

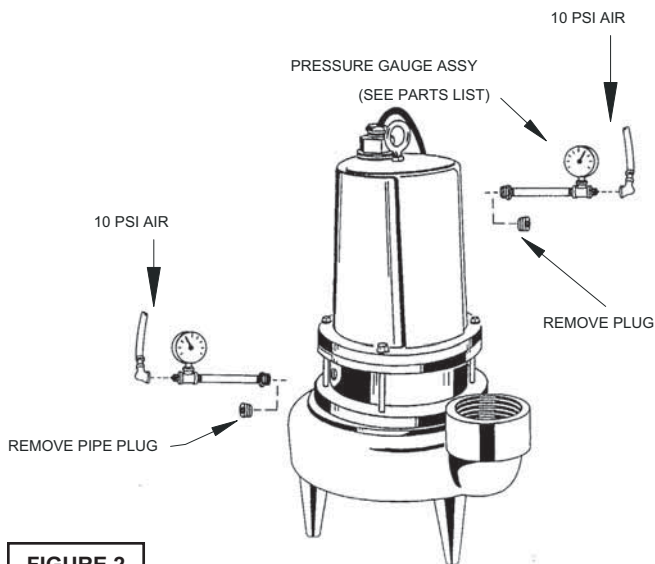

FIGURE 2

F-2) Impeller and Volute Service:

F-2.1) Disassembly and Inspection:

To clean out volute (24) or replace impeller (29), disconnect power, remove hex nuts (12), and lockwasher (11), vertically lift motor and seal plate assembly from body (24). Clean out body if necessary. Clean and examine impeller (29), for pitting or wear and replace if required, inspect gasket (10) and replace if cut or damaged. If the impeller (29) needs replacing, remove nut (3), place a flat screwdriver in the slot of the end of the shaft to hold the shaft stationary while unscrewing the impeller (29).

F-2.2) Reassembly:

To install impeller (29), screw impeller onto the shaft hand tight. Clean the threads with Loctite cleaner. Apply thread locking compound to shaft threads and install nut (3). Torque to 40 ft. lbs. Rotate impeller to check for binding.

Position gasket (10) on volute flange and position impeller and motor housing on volute (28). Position lockwasher (11) on cap screw (12) and screw into volute (28). Torque to 8 ft. lbs. Check for free rotation of motor and impeller.

F-3) Motor and Bearing Service

F-3.1) Disassembly and Inspection:

To examine or replace the motor (20) and bearings (6) and (42), disassemble volute and impeller as outlined in paragraph F-2.1. Drain oil from motor and seal chamber as outlined in paragraph F-1.3. Disassemble shaft seal as outlined in paragraph F-4.1.

Position unit upright, using blocks to avoid resting unit on shaft. Remove socket head cap screws (9). Vertically lift the outside motor housing (5) from seal plate (52) by lifting eye (17). Inspect square ring (8) for damage or cuts. Remove cable assembly (30) by unscrewing gland nut (30a), gland nut (32a), and hex nut (16) from motor housing (5). Remove cable lead wires from motor lead wires and sensors wires from control cable by disconnecting connectors (23) and (40). The unit voltage should be noted. Remove the motor bolts and lift motor (20) from seal plate (52). Examine bearing (6) and replace if required. If replacement is required, remove retaining ring (2) then remove bearing (6) from motor shaft using a wheel puller or arbor press.

Vertically lift motor stator from rotor. Inspect bearing (42), belleville washers (43) and spacer (44) if replacement is required, remove belleville washers (43) and spacer (44) from motor shaft, remove bearing (42) from motor shaft using a wheel puller or arbor press. Inspect winding for shorts and check resistance values. To test the temperature sensor (if equipped), check for continuity between the black and white wires. If found to be defective contact a motor service station or Weinman service department. Check rotor for wear. If rotor or the stator windings are defective, the complete motor must be replaced. Check motor capacitor (21), on single phase units and replace if defective. Check moisture sensors (46) for damage and replace if necessary.



Important ! - ALL parts must be clean before reassembly.

F-3.2) Reassembly:

Bearings - When replacing bearings, be careful not to damage the rotor or shaft threads. Clean the shaft thoroughly. Apply adhesive compound to the shaft and press bearing (6) on the motor shaft, position squarely onto the shaft applying force to the inner race of the bearing only, until bearing seats against the retaining ring (2).

Apply adhesive compound to the other end of motor shaft and press bearing (42) on, positioning squarely on the shaft shoulder, applying force to inner race of bearing only. Position belleville washer (43), spacer (44) and another belleville washer (43), with curvatures pointing away from spacer (44), on motor shaft above bearing (42) and lower motor stator over rotor.

Motor - Slide lower bearing (6) and motor (20) squarely into the seal plate (1) until bearing seats on the bottom. Torque motor bolts to 17 inch pounds. Make wire connections per paragraph F-3.3. Set square ring (8) in groove on seal plate (1), lower motor housing (5) down onto seal plate (1) while aligning holes. Place socket head cap screws (9) through seal plate (1) into motor housing (5) and torque to 60 inch pounds.

F-3.3) Wiring Connections:

Check power cable (30) and control cable (32) for cracks or damage and replace if required (see Fig. 4). Place parts (30a,b&c) and hex nut (16) on power cord (30), and parts (32a,b &c) on control cable (32). Bring cord sets (30) and (32) through opening in top of motor housing (5), and reconnect motor leads to power cable (30) and sensor leads to control cable (32) using connectors (23), and in addition use (40) and (41) for 3 phase, as show in Fig. 3.

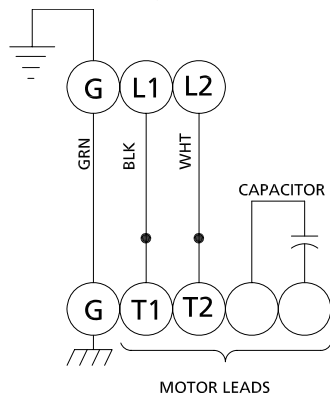

SINGLE PHASE, 115/230 VOLT AC

Power Cable (30)	Motor Lead Number
Green (Ground)	Green
Black	1
White	2
Flag Terminal	Capacitor
Flag Terminal	Capacitor

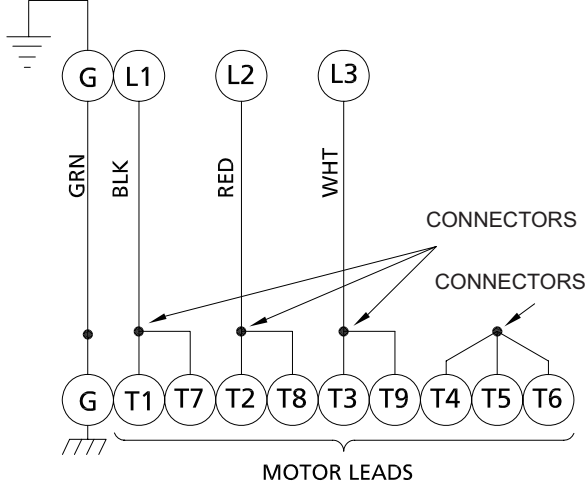

THREE PHASE, 200/230 VOLT AC

Power Cable (30)	Motor Lead Number
Green (Ground)	Green
Black	1 & 7
Red	2 & 8
White	3 & 9
	4, 5 & 6 Together

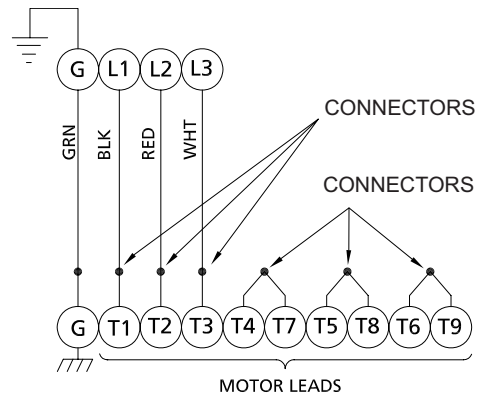

THREE PHASE, 460 VOLT AC

Power Cable (30)	Motor Lead Number
Green (Ground)	Green
Black	1
Red	2
White	3
	4 & 7 Together
	5 & 8 Together
	6 & 9 Together

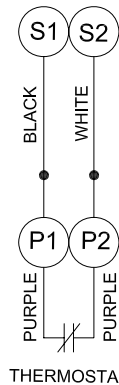

TEMPERATURE SENSOR ONLY

Control Cable (32)	Lead Number
Black	P1 (Thermo Sensor)
White	P2 (Thermo Sensor)

CONTROL Small Cable

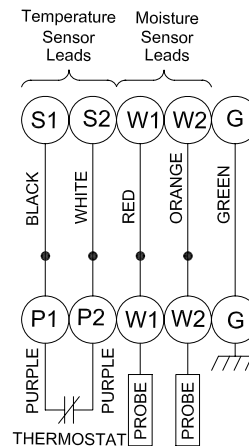

MOISTURE & TEMPERATURE SENSORS

Control Cable (32)	Lead Number
Black	P1 (Thermo Sensor)
White	P2 (Thermo Sensor)
Red	W1 (Moisture Sensor)
Orange	W2 (Moisture Sensor)
Green	Ground

FIGURE 3

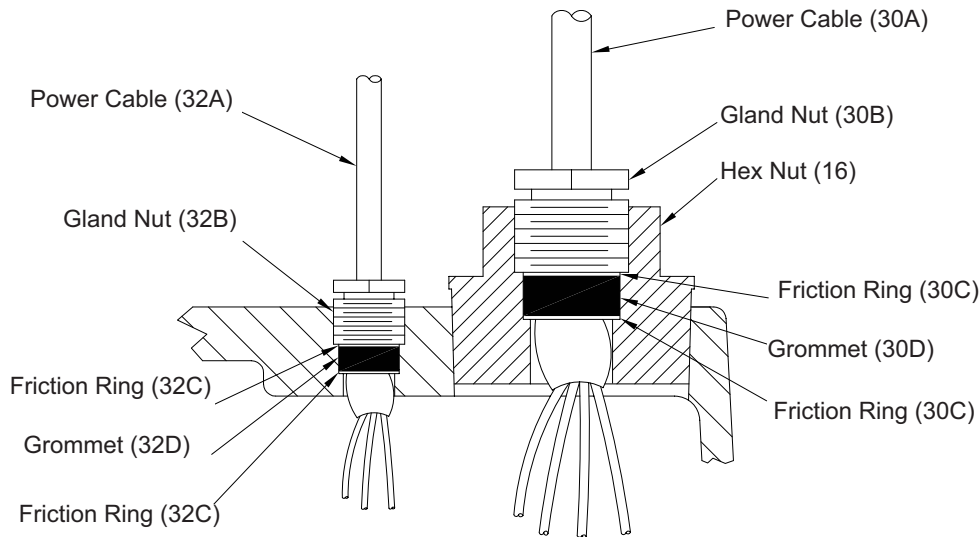

FIGURE 4

F-3.4) Cable Assemblies:

Power Cable - Refill with cooling oil (if it has been drained) as outlined in paragraph F-1.3. Make wire connections as outlined in paragraph F-3.3. Apply thread locking compound to hex nut (16) and tighten into motor housing (5). Insert one friction ring (30c), grommet (30d), another friction ring (30c) and gland nut (30b) into hex nut (16) and tighten gland nut (30b) to 15 ft. lbs. to prevent water leakage (see Fig. 4).

Control Cable - Insert one friction ring (32c), grommet (32d), one friction ring (32c) and gland nut (32b) into motor housing (5). Torque gland nut (32b) to 15 ft. lbs to prevent water leakage.

F-4) Shaft Seal Service:

Important ! - Handle seal parts with extreme care. DO NOT scratch or mar lapped surfaces.

F-4.1) Disassembly and Inspection:

OUTER SEAL -To expose outer shaft seal (31) for examination disassemble volute and impeller as outlined in paragraph F-2.1. If further repair is required remove retaining ring (31d), spring (31c) and rotating member (31b) from shaft (see Fig. 5). Examine all seal parts and especially contact faces. Inspect seal for signs of wear such as uneven wear pattern on stationary members, chips and scratches on either seal face. **DO NOT** interchange seal components, replace the entire shaft seal (31). If replacing seal, remove stationary (31a) by prying out with flat screw driver.

INNER SEAL- To expose inner shaft seal (31) for examination, remove outer seal as outlined above. Remove socket head cap screw (51). Lift seal plate (1), spacer (50) and square rings (8) from seal plate (52). If replacement is required remove retaining ring (49), retaining ring (31d), spring (31c) and rotating member (31b) from shaft. Examine as outlined in outer seal paragraph.

F-4.2) Reassembly:

Seal - Clean and oil seal cavities in seal plate (1). Lightly oil (**DO NOT use grease**) outer surface of stationary member (31a). Press stationary member (31a) firmly into seal plate (1), using a seal pusher (see parts list- Seal Tool kit), nothing but the seal pusher is to come in contact with seal face (see Fig. 6).

Important ! - DO NOT hammer on the seal pusher- it will damage the seal face.

Make sure the stationary member is in straight. Slide a bullet (see parts list-seal tool kit) over motor shaft. Lightly oil (**DO NOT use grease**) shaft, bullet and inner surface of bellows on rotating member (31b) see Fig. 7. With lapped surface of rotating member (31b) facing inward toward stationary member (31a), slide rotating member (31b) over bullet and onto shaft, using seal pusher, until lapped faces of (31a) and (31b) are together (see Fig. 5).

Important ! - It is extremely important to keep seal faces clean during assembly. Dirt particles lodged between these faces will cause the seal to leak.

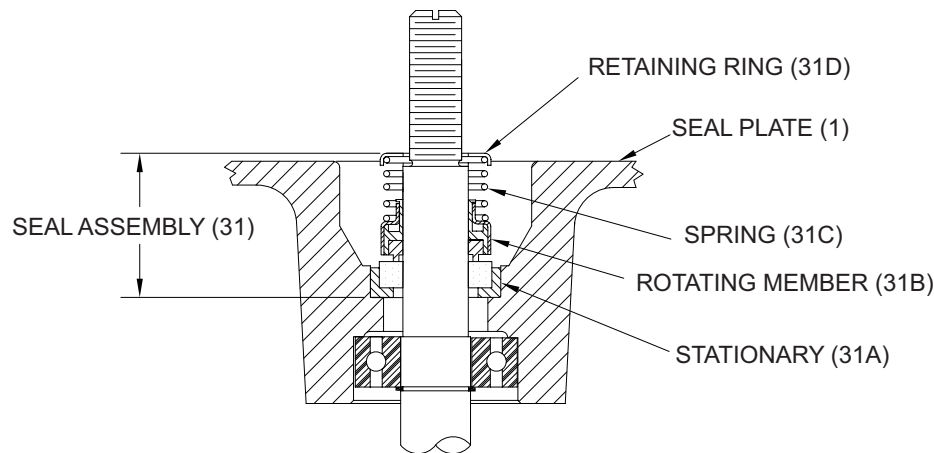

FIGURE 5

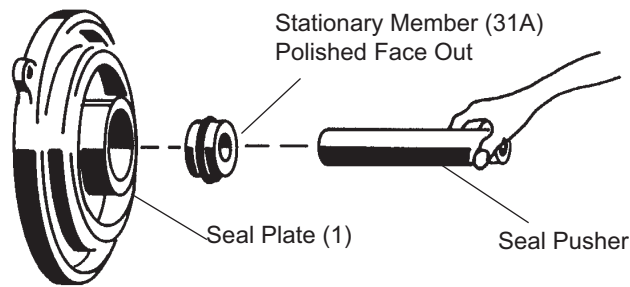

FIGURE 6

Place spring (31c) over shaft and in place on rotating member (31b), making sure it is seated on retainer and not cocked or resting on bellows tail. Slide retaining ring (31d) over shaft and let rest on spring (31c). Replace retaining ring (49) onto shaft. Set one square ring (8) in groove on seal plate (52) and lower spacer (50) onto seal plate (52). Seat one square ring (8) onto groove on spacer (50) and lower seal plate (1) onto spacer (50). Insert two socket head cap screws (51) and torque to 60 inch pounds. Repeat insertion of seal for outer seal. Assemble impeller and volute as outlined in paragraph F-2.2. Replace oil as outlined in paragraph F-1.3.

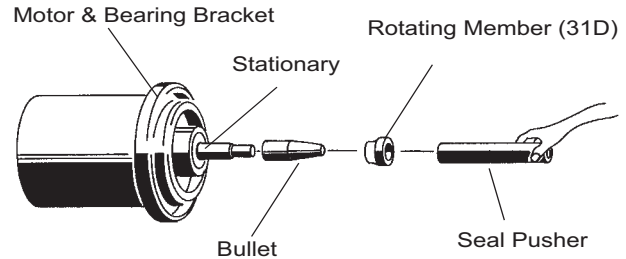

FIGURE 7

SECTION: G REPLACEMENT PARTS
G-1 ORDERING REPLACEMENT PARTS:

When ordering replacement parts, ALWAYS furnish the following information:

1. Pump serial number and date code. (Paragraph G-4)
2. Pump model number. (Paragraph G-3)
3. Pump part number. (Paragraph G-2)
4. Part description.
5. Item part number.
6. Quantity required.
7. Shipping instructions.
8. Billing Instructions.

WARNING

HP	VOLTS	PH.	HZ.
RPM	FLA	CODE	
MODEL NO.		2	
SERIAL NO. 1			
AMBIENT	°C	INS. CLASS	
PART NO. 3		IMP. DIA.	

Made in USA

G-2 PART NUMBER:

The part number consists of a six (6) digit number, which appears in the catalog. A one or two letter suffix may follow this number to designate the design configuration. This number is used for ordering and obtaining information.

G-3 MODEL NUMBER:

This designation consists of numbers and letters which represent the discharge size, series, horsepower, motor phase and voltage, speed and pump design. This number is used for ordering and obtaining information.

G-4 SERIAL NUMBER:

The serial number block will consist of a six digit number, which is specific to each pump and may be preceded by a alpha character, which indicates the plant location. This number will also be suffixed with a four digit number, which indicates the date the unit was built (Date Code). EXAMPLE: A012345 0490.

Reference the six digit portion (Serial Number) of this number when referring to the product.

TROUBLE SHOOTING

CAUTION ! Always disconnect the pump from the electrical power source before handling.
If the system fails to operate properly, carefully read instructions and perform maintenance recommendations.
If operating problems persist, the following chart may be of assistance in identifying and correcting them:

MATCH "CAUSE" NUMBER WITH CORRELATING "CORRECTION" NUMBER.

NOTE: Not all problems and corrections will apply to each pump model.

PROBLEM	CAUSE	CORRECTION
Pump will not run	<ol style="list-style-type: none"> 1. Poor electrical connection, blown fuse, tripped breaker or other interruption of power, improper power supply. 2. Motor or switch inoperative (to isolate cause, go to manual operation of pump). <ol style="list-style-type: none"> 2a. Float movement restricted. 2b. Switch will not activate pump or is defective. 2c. Defective motor 3. Insufficient liquid level. 	<ol style="list-style-type: none"> 1. Check all electrical connections for security. Have electrician measure current in motor leads, if current is within $\pm 20\%$ of locked rotor Amps, impeller is probably locked. If current is 0, overload may be tripped. Remove power, allow pump to cool, then recheck current. 2a. Reposition pump or clean basin as required to provide adequate clearance for float.
Pump will not turn off	<ol style="list-style-type: none"> 2a. Float movement restricted. 2b. Switch will not activate pump or is defective. 4. Excessive inflow or pump not properly sized for application. 9. Pump may be airlocked 14. H-O-A switch on panel is in "HAND" position 	<ol style="list-style-type: none"> 2b. Disconnect level control. Set ohmmeter for a low range, such as 100 ohms full scale and connect to level control leads. Actuate level control manually and check to see that ohmmeter shows zero ohms for closed switch and full scale for open switch. (Float Switch). 2c. Check winding insulation (Megger Test) and winding resistance. If check is outside of range, dry and recheck. If still defective, replace per service instructions.
Pump hums but does not run	<ol style="list-style-type: none"> 1. Incorrect voltage 8. Impeller jammed or loose on shaft, worn or damaged, impeller cavity or inlet plugged. 	<ol style="list-style-type: none"> 2c. Check winding insulation (Megger Test) and winding resistance. If check is outside of range, dry and recheck. If still defective, replace per service instructions.
Pump delivers insufficient capacity	<ol style="list-style-type: none"> 1. Incorrect voltage. 4. Excessive inflow or pump not properly sized for application. 5. Discharge restricted. 6. Check valve stuck closed or installed backwards. 7. Shut-off valve closed. 8. Impeller jammed or loose on shaft, worn or damaged, impeller cavity or inlet plugged. 9. Pump may be airlocked. 10. Pump running backwards 	<ol style="list-style-type: none"> 3. Make sure liquid level is at least equal to suggested turn-on point. 4. Recheck all sizing calculations to determine proper pump size. 5. Check discharge line for restrictions, including ice if line passes through or into cold areas. 6. Remove and examine check valve for proper installation and freedom of operation. 7. Open valve.
Pump cycles too frequently or runs periodically when fixtures are not in use	<ol style="list-style-type: none"> 6. Check valve stuck closed or installed backwards. 11. Fixtures are leaking. 15. Ground water entering basin. 	<ol style="list-style-type: none"> 8. Check impeller for freedom of operation, security and condition. Clean impeller and inlet of any obstruction. 9. Loosen union slightly to allow trapped air to escape. Verify that turn-off level of switch is set so that the suction is always flooded. Clean vent hole.
Pump shuts off and turns on independent of switch, (trips thermal overload protector). CAUTION! Pump may start unexpectedly. Disconnect power supply.	<ol style="list-style-type: none"> 1. Incorrect voltage. 4. Excessive inflow or pump not properly sized for application. 8. Impeller jammed, loose on shaft, worn or damaged, impeller cavity or inlet plugged. 12. Excessive water temperature. (internal protection only) 	<ol style="list-style-type: none"> 10. Check rotation. If power supply is three phase, reverse any two of three power supply leads to ensure proper impeller rotation.. 11. Repair fixtures as required to eliminate leakage.
Pump operates noisily or vibrates excessively	<ol style="list-style-type: none"> 2c. Worn bearings, motor shaft bent. 5. Debris in impeller cavity or broken impeller 10. Pump running backwards 13. Piping attachments to building structure too rigid or too loose. 	<ol style="list-style-type: none"> 12. Check pump temperature limits & fluid temperature. 13. Replace portion of discharge pipe with flexible connector. 14. Turn to automatic position. 15. Check for leaks around basin inlet and outlets.

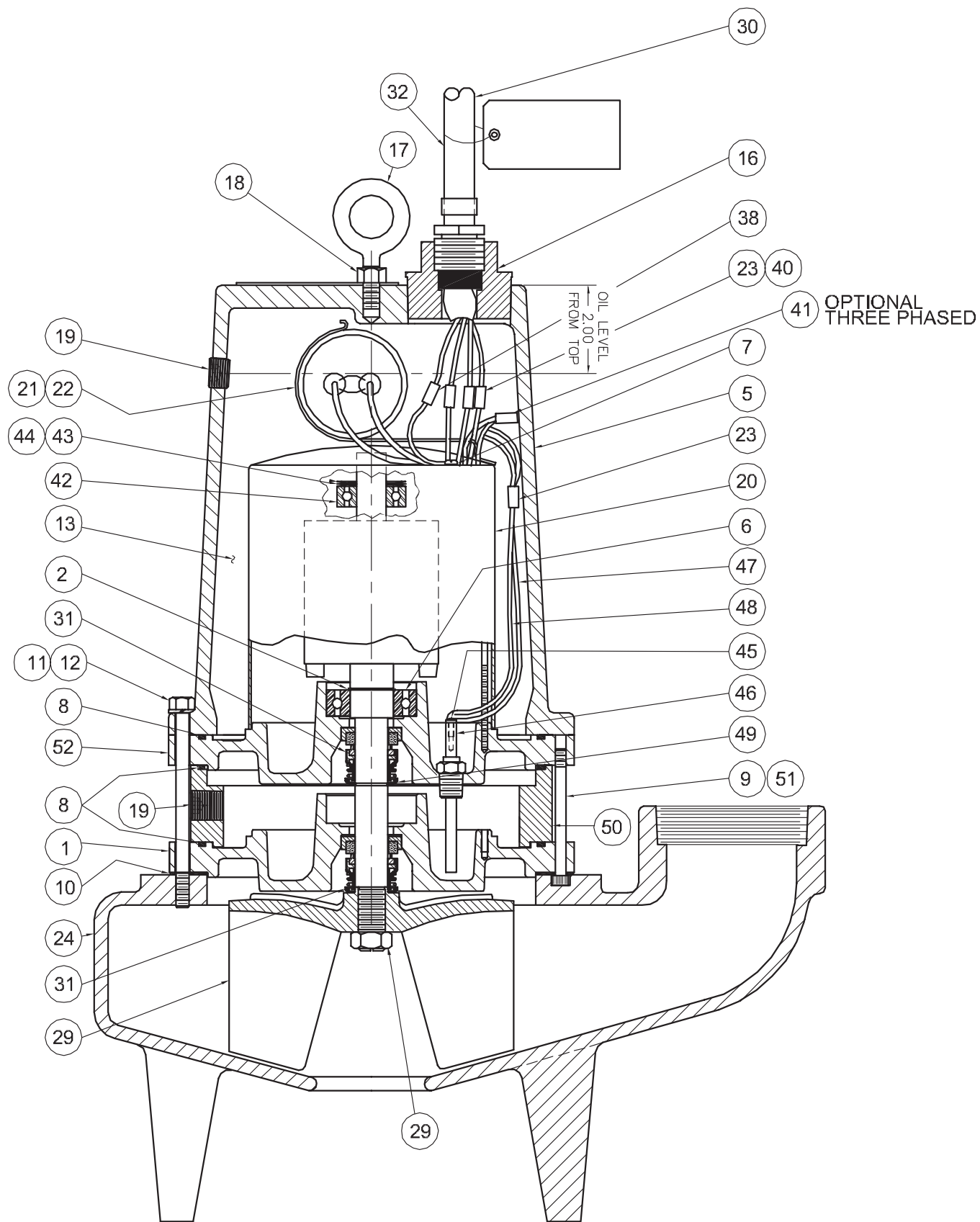
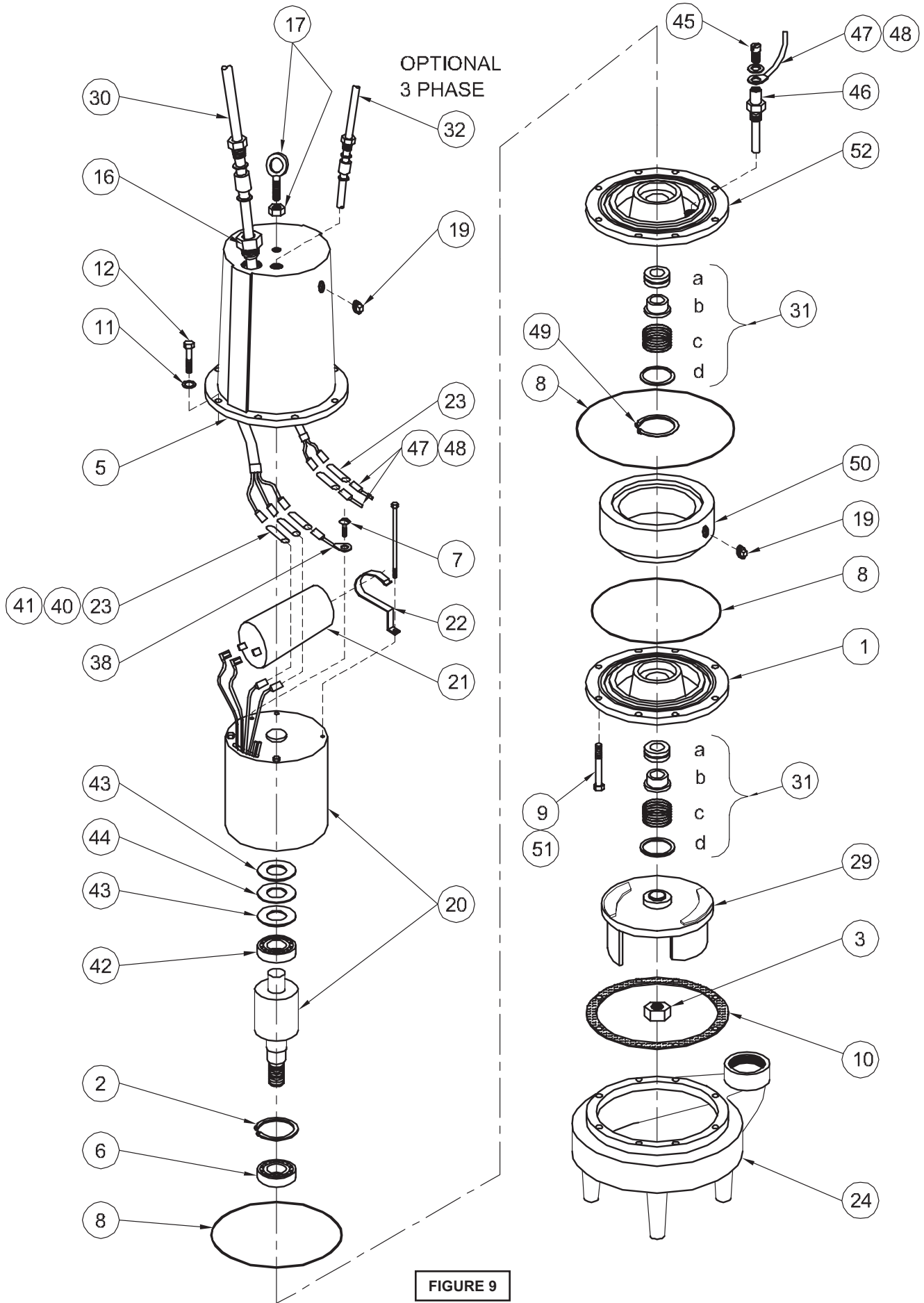

FIGURE 8



PARTS KITS

Seal Repair Kit.....P/N-085465 (+) 3, 8, 10, 31
Overhaul Kit.....P/N-085210 (◆) 2, 3, 6, 8, 10, 23, 30C, 30D, 31, 40, 41, 42
Seal Tool Kit.....TL-21360
Pressure Gauge Kit...P/N-085343

PARTS LIST - Standard

ITEM	QTY	PART NO.	DESCRIPTION
1	1	084343	Seal Plate
2	1	061143	◆ Retaining Ring
3	1	038132	◆+ Nut 5/8-18 Stainless
5	1	084550HA 084550	Motor Housing, with Moisture and/or Temp. Sensors. No Sensor
6	1	039734	◆ Bearing
7	1	016660	Screw #8-32 x 3/8" lg stainless
8	3	027269	◆+ Square Ring
9	2	084948	Soc. Hd Cap Screw 1/4-20 x 1-1/4" lg stainless
10	1	027344	◆+ Gasket
11	4	026322	Lockwasher 5/16 stainless
12	4	064114	Cap Screw 5/16-18 x 4-1/2" lg stainless
13	1Gal. 1.2 qts.	029034	Oil (Motor Housing) (Seal Chamber)
16	1	084534	Hex Hd. Plug
17	1	085666	Eye Bolt & Nut 3/8-16 x 1" Lg Stainless
19	2	014270	Pipe Plug 1/8 NPT
20	1	084382MB 084383MB 092859	Motor 3WE1524DS,2024 3WE1594DS,1544,2094,2044 3WE1554DS,2054
21	1	036391	Capacitor (single phase) 370V, 45MFD
22	1	039858	Capacitor Bracket (single phase)
23	3	079318	◆ Terminal Connector (single phase)
	4	079318	Terminal Connector (three phase)
	4	079318	Terminal Connector (sensors)
24	1	084399	Volute
29	1	084439 084439TA 084439TB 084439TC 084439TD 084439TE 084439TF 084439TG 084439TH 084439TJ 084439TK 084439TL 084439TM 084439TN 084439TP 084439TQ 084439TR 084439TS 084439TT 084439TU 084439TV	Impeller, Cast Iron 7.00 Dia. 6.88 Dia. 6.75 Dia. 6.62 Dia. 6.50 Dia. (STD. for 2HP) 6.38 Dia. 6.25 Dia. 6.12 Dia. 6.00 Dia. (STD. for 1.5HP) 5.88 Dia. 5.75 Dia. 5.62 Dia. 5.50 Dia. 5.38 Dia. 5.25 Dia. 5.12 Dia. 5.00 Dia. 4.88 Dia. 4.75 Dia. 4.62 Dia. 4.50 Dia.
30	1	See Table 2	Power Cable Set
30a	1	----	* Cable (Not Sold Separately)
30b	1	051447	* Gland Nut
30c	2	066071	*◆ Friction Ring (single phase)
		051450	* Friction Ring (three phase)
30d	1	066072	*◆ Grommet (single phase)
		051452	* Grommet (three phase)

(*) Included with item number 30.

31	2	067562	◆+	Shaft Seal, Inner	Carbon/Ceramic/Buna-N (STD)
		067562SB		Tungsten/Tugsten/Buna-N	
		067562SD		Silicon/Silicon/Buna-N	
		067562SF		Carbon/Ceramic/Viton	
		067562SH		Tungsten/Tugsten/Viton	
		067562SK		Silicon/Silicon/Viton	
		067562		Shaft Seal, Outer	Carbon/Ceramic/Buna-N (STD)
		067562SB		Tungsten/Tugsten/Buna-N	
		067562SD		Silicon/Silicon/Buna-N	
		067562SF		Carbon/Ceramic/Viton	
		067562SH		Tungsten/Tugsten/Viton	
		067562SK		Silicon/Silicon/Viton	
32	1	See Table 2		Control Cable Set	
32a	1	-----	†	Cable	(Not Sold Separately)
32b	1	051448	†	Gland Nut	
32c	2	021531	†	Friction Ring	
32d	1	066871	†	Grommet	
38	1	085073-WE		Wire Assembly	
40	3	071363	◆	Terminal Connector	(Three Phase 200-230V)
	7	071363		Terminal Connector	(Three Phase 460 & 575V)
	3	026880		Terminal Connector	(Three Phase 460 & 575V)
41	1	019212	◆	Wire Connector	(Three Phase)
42	1	017414	◆	Bearing	
43	2	085282		Belleville Washer	
44	1	085283		Spacer	
45	2	038156		Screw	6-32 x 3/8" lg zinc plt
46	2	066843		Moisture Sensor	
47	1	084957WT		Wire Assembly	
48	1	084958WT		Wire Assembly	
49	1	018370		Retaining Ring	
50	1	084440		Spacer	
51	2	067519		Soc. Hd. Cap Screw	1/4-20 x 3" lg Stainless
52	1	084429		Seal Plate	(for moisture sensors)
53	2	003217		Plug	Replaces Item #46 for no sensor

TABLE 2 - POWER & SENSOR CORD SETS				
MODELS/ LENGTH	ITEM #30 1 PHASE	ITEM #30 3 PHASE	ITEM #32 MOIST/TEMP. SENSOR	ITEM #32 TEMP SENSOR
15 Ft.	085399	085092	079031	071769
20 Ft.	085399XA	085092XA	079031XA	071769XA
25 Ft. (STD)	085399XB	085092XB	079031XB	071769XB
30 Ft.	085399XC	085092XC	079031XC	071769XC
35 Ft.	085399XD	085092XD	079031XD	071769XD
40 Ft.	085399XE	085092XE	079031XE	071769XE
50 Ft.	085399XF	085092XF	079031XF	071769XF
60 Ft.	085399XG	085092XG	079031XG	071769XG
70 Ft.	085399XH	085092XH	079031XH	071769XH
80 Ft.	085399XJ	085092XJ	079031XJ	071769XJ
90 Ft.	085399XK	085092XK	079031XK	071769XK
100 Ft.	085399XL	085092XL	079031XL	071769XL
150 Ft.	085399XS	085092XS	079031XS	071769XS
200 Ft.	085399XY	085092XY	079031XY	071769XY

(f) Included with item number 32.

BARNES®



burks®

WEINMAN®

DEMING®

PROSSER®

Limited 24 Month Warranty

Crane Pumps & Systems warrants that products of our manufacture will be free of defects in material and workmanship under normal use and service for twenty-four (24) months after manufacture date, when installed and maintained in accordance with our instructions. This warranty gives you specific legal rights, and there may also be other rights which vary from state to state. In the event the product is covered by the Federal Consumer Product Warranties Law (1) the duration of any implied warranties associated with the product by virtue of said law is limited to the same duration as stated herein, (2) this warranty is a LIMITED WARRANTY, and (3) no claims of any nature whatsoever shall be made against us, until the ultimate consumer, his successor, or assigns, notifies us in writing of the defect, and delivers the product and/or defective part(s) freight prepaid to our factory or nearest authorized service station. Some states do not allow limitations on how long an implied warranty lasts, so the above limitation may not apply. **THE SOLE AND EXCLUSIVE REMEDY FOR BREACH OF ANY AND ALL WARRANTIES WITH RESPECT TO ANY PRODUCT SHALL BE TO REPLACE OR REPAIR AT OUR ELECTION, F.O.B. POINT OF MANUFACTURE OR AUTHORIZED REPAIR STATION, SUCH PRODUCTS AND/OR PARTS AS PROVEN DEFECTIVE. THERE SHALL BE NO FURTHER LIABILITY, WHETHER BASED ON WARRANTY, NEGLIGENCE OR OTHERWISE.** Unless expressly stated otherwise, guarantees in the nature of performance specifications furnished in addition to the foregoing material and workmanship warranties on a product manufactured by us, if any, are subject to laboratory tests corrected for field performance. Any additional guarantees, in the nature of performance specifications must be in writing and such writing must be signed by our authorized representative. Due to inaccuracies in field testing if a conflict arises between the results of field testing conducted by or for user, and laboratory tests corrected for field performance, the latter shall control. **RECOMMENDATIONS FOR SPECIAL APPLICATIONS OR THOSE RESULTING FROM SYSTEMS ANALYSES AND EVALUATIONS WE CONDUCT WILL BE BASED ON OUR BEST AVAILABLE EXPERIENCE AND PUBLISHED INDUSTRY INFORMATION. SUCH RECOMMENDATIONS DO NOT CONSTITUTE A WARRANTY OF SATISFACTORY PERFORMANCE AND NO SUCH WARRANTY IS GIVEN.**

This warranty shall not apply when damage is caused by (a) improper installation, (b) improper voltage (c) lightning (d) excessive sand or other abrasive material (e) scale or corrosion build-up due to excessive chemical content. Any modification of the original equipment will also void the warranty. We will not be responsible for loss, damage or labor cost due to interruption of service caused by defective parts. Neither will we accept charges incurred by others without our prior written approval.

This warranty is void if our inspection reveals the product was used in a manner inconsistent with normal industry practice and/or our specific recommendations. The purchaser is responsible for communication of all necessary information regarding the application and use of the product. **UNDER NO CIRCUMSTANCES WILL WE BE RESPONSIBLE FOR ANY OTHER DIRECT OR CONSEQUENTIAL DAMAGES, INCLUDING BUT NOT LIMITED TO TRAVEL EXPENSES, RENTED EQUIPMENT, OUTSIDE CONTRACTOR FEES, UNAUTHORIZED REPAIR SHOP EXPENSES, LOST PROFITS, LOST INCOME, LABOR CHARGES, DELAYS IN PRODUCTION, IDLE PRODUCTION, WHICH DAMAGES ARE CAUSED BY ANY DEFECTS IN MATERIAL AND/OR WORKMANSHIP AND/OR DAMAGE OR DELAYS IN SHIPMENT. THIS WARRANTY IS EXPRESSLY IN LIEU OF ANY OTHER EXPRESS OR IMPLIED WARRANTY, INCLUDING ANY WARRANTY OF MERCHANTABILITY OR FITNESS FOR A PARTICULAR PURPOSE.**

No rights extended under this warranty shall be assigned to any other person, whether by operation of law or otherwise, without our prior written approval.

CRANE®

A Crane Co. Company

PUMPS & SYSTEMS

420 Third Street
Piqua, Ohio 45356
Phone: (937) 778-8947
Fax: (937) 773-7157
www.cranepumps.com

83 West Drive, Bramton
Ontario, Canada L6T 2J6
Phone: (905) 457-6223
Fax: (905) 457-2650

**IMPORTANT!
WARRANTY REGISTRATION**

Your product is covered by the enclosed Warranty.
To complete the Warranty Registration Form go to:

<http://www.cranepumps.com/ProductRegistration/>

If you have a claim under the provision of the warranty, contact your local
Crane Pumps & Systems, Inc. Distributor.

RETURNED GOODS

**RETURN OF MERCHANDISE REQUIRES A "RETURNED GOODS AUTHORIZATION".
CONTACT YOUR LOCAL CRANE PUMPS & SYSTEMS, INC. DISTRIBUTOR.**



**Products Returned Must Be Cleaned, Sanitized,
Or Decontaminated As Necessary Prior To Shipment,
To Insure That Employees Will Not Be Exposed To Health
Hazards In Handling Said Material. All Applicable Laws
And Regulations Shall Apply.**