

WEINMAN®

INSTALLATION AND OPERATION MANUAL SPLIT CASE PUMPS

Sections: 1100, 1200 & 1310

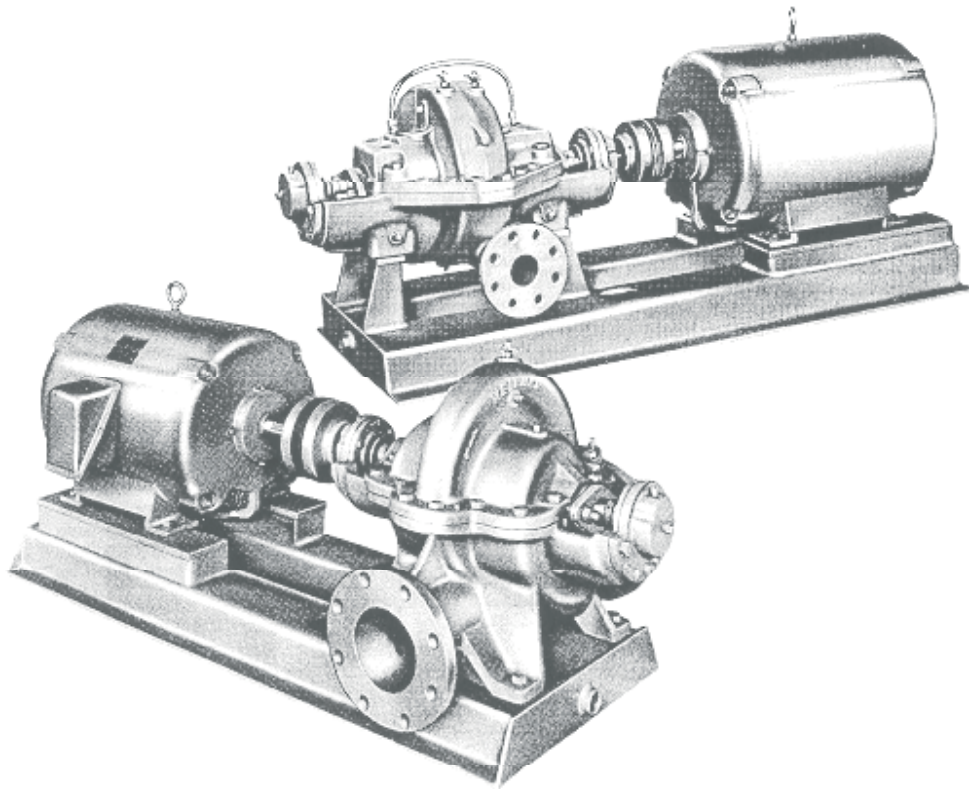

IMPORTANT!

*Read all instructions in this manual before operating pump.
As a result of Crane Pumps & Systems, Inc., constant product improvement program,
product changes may occur. As such Crane Pumps & Systems reserves the right to
change product without prior written notification.*

CRANE[®]

A Crane Co. Company

PUMPS & SYSTEMS

420 Third Street
Piqua, Ohio 45356
Phone: (937) 778-8947
Fax: (937) 773-7157
www.cranepumps.com

83 West Drive, Brampton
Ontario, Canada L6T 2J6
Phone: (905) 457-6223
Fax: (905) 457-2650

Form No. 096860-Rev. J

SAFETY FIRST!

Please Read This Before Installing Or Operating Pump. This information is provided for **SAFETY** and to **PREVENT EQUIPMENT PROBLEMS**. To help recognize this information, observe the following symbols:



IMPORTANT! Warns about hazards that can result in personal injury or Indicates factors concerned with assembly, installation, operation, or maintenance which could result in damage to the machine or equipment if ignored.

CAUTION! Warns about hazards that **can or will cause minor** personal injury or property damage if ignored. Used with symbols below.

WARNING! Warns about hazards that can or will cause serious personal injury, death, or major property damage if ignored. Used with symbols below.



Hazardous fluids can cause fire or explosions, burns or death could result.



Extremely hot - Severe burns can occur on contact.



Biohazard can cause serious personal injury.



Hazardous fluids can Hazardous pressure, eruptions or explosions could cause personal injury or property damage.



Rotating machinery Amputation or severe laceration can result.



Hazardous voltage can shock, burn or cause death.

Only qualified personnel should install, operate and repair pump. Any wiring of pumps should be performed by a qualified electrician.

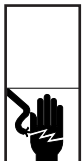

WARNING ! To reduce risk of electrical shock, pumps and control panels must be properly grounded in accordance with the National Electric Code (NEC) or the Canadian Electrical Code (CEC) and all applicable state, province, local codes and ordinances. Improper grounding voids warranty.



WARNING! To reduce risk of electrical shock, always disconnect the pump from the power source before handling or servicing. Lock out power and tag.



WARNING! Operation against a closed discharge valve will cause premature bearing and seal failure on any pump, and on end suction and self priming pump the heat build may cause the generation of steam with resulting dangerous pressures. It is recommended that a high case temperature switch or pressure relief valve be installed on the pump body.



CAUTION ! Pumps build up heat and pressure during operation-allow time for pumps to cool before handling or servicing.



WARNING ! Do not pump hazardous materials (flammable, caustic, etc.) unless the pump is specifically designed and designated to handle them.



WARNING ! Do not wear loose clothing that may become entangled in moving parts.



WARNING ! Keep clear of suction and discharge openings. **DO NOT** insert fingers in pump with power connected.



Make sure lifting handles are securely fastened each time before lifting. **DO NOT** operate pump without safety devices in place. Always replace safety devices that have been removed during service or repair. Secure the pump in its operating position so it can not tip over, fall or slide.



DO NOT exceed manufacturers recommendation for maximum performance, as this could cause the motor to overheat.



WARNING ! To reduce risk of electrical shock, all wiring and junction connections should be made per the NEC or CEC and applicable state or province and local codes. Requirements may vary depending on usage and location.



WARNING! Products returned must be cleaned, sanitized, or decontaminated as necessary prior to shipment, to insure that employees will not be exposed to health hazards in handling said material. All Applicable Laws And Regulations Shall Apply.



Bronze/brass and bronze/brass fitted pumps may contain lead levels higher than considered safe for potable water systems. Lead is known to cause cancer and birth defects or other reproductive harm. Various government agencies have determined that leaded copper alloys should not be used in potable water applications. For non-leaded copper alloy materials of construction, please contact factory.



Crane Pumps & Systems, Inc. is not responsible for losses, injury, or death resulting from a failure to observe these safety precautions, misuse or abuse of pumps or equipment.

GENERAL INFORMATION

TO THE PURCHASER:

Congratulations! You are the owner of one of the finest pumps on the market today. These pumps are products engineered and manufactured of high quality components. With years of pump building experience along with a continuing quality assurance program combine to produce a pump which will stand up to the toughest applications.

Check local codes and requirements before installation. Servicing should be performed by knowledgeable pump service contractors or authorized service stations.

RECEIVING:

Upon receiving the pump, it should be inspected for damage or shortages. If damage has occurred, file a claim immediately with the company that delivered the pump. If the manual is removed from the crating, do not lose or misplace.

STORAGE:

Short Term - Pumps are manufactured for efficient performance following long inoperative periods in storage. For best results, pumps can be retained in storage, as factory assembled, in a dry atmosphere with constant temperatures for up to six (6) months.

Long Term - Any length of time exceeding six (6) months, but not more than twenty four (24) months. The units should be stored in a temperature controlled area, a roofed over walled enclosure that provides protection from the elements (rain, snow, wind blown dust, etc.), and whose temperature can be maintained between +40 deg. F and +120 deg. F. Pump should be stored in its original shipping container and before initial start up, rotate impeller by hand to assure seal and impeller rotate freely.

SERVICE CENTERS:

For the location of the nearest Weinman Service Center, check your Weinman representative or Crane Pumps & Systems Inc., Service Department in Piqua, Ohio, telephone (937) 778-8947 or Crane Pumps & Systems Canada, Inc., Brampton, Ontario, (905) 457-6223.

INSTALLATION

1. FOUNDATION

The pump foundation should be sufficiently substantial to form a level, rigid support for the combined weight of the pump and driver and maintain alignment of the installed unit. Foundation bolts, of the proper size, should be imbedded in the concrete. A pipe sleeve, about 2½" diameters larger than the bolt, should be used to allow for final positioning of the bolts. See Figure 1.

2. MOUNTING:

Horizontal mounted pumps and drivers that are received from the factory with both machines mounted on a common baseplate, were accurately aligned before shipment. Vertical mounted pumps were accurately aligned before shipment.

All baseplates are flexible to some extent and, therefore, must not be relied upon to maintain the factory alignment. Preliminary alignment may be necessary after the complete unit has been leveled on the foundation, and again, after the unit is piped (See Fig 4), and rechecked periodically as outlined in the following paragraphs.

Position unit on foundation and level the baseplate, using rectangular metal blocks and shims, or wedges having a small taper as shown in Figure 2. A gap of 3/4" to 1½" should be allowed between the baseplate and foundation for grouting.

Adjust the metal supports or wedges until the shafts of the pump and driver are level. Check the coupling faces, as well as the suction and discharge flanges of the pump for horizontal or vertical position by means of a level. Correct the positions, if necessary, by adjusting the supports or wedges under the baseplate, as required.

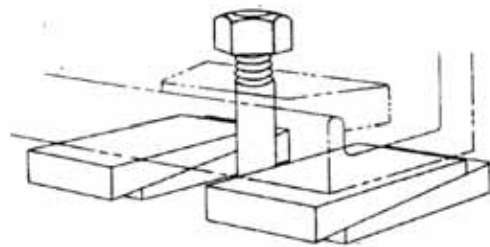

Figure 2. Adjusting Wedges for Mounting

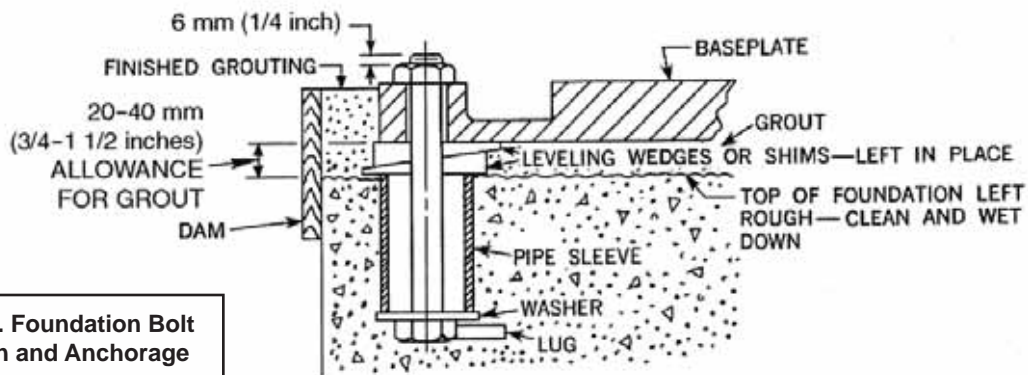

Figure 1. Foundation Bolt Location and Anchorage

NOTE: A flexible coupling should not be used to compensate for misalignment of the pump and driver shafts. The purpose of the flexible coupling is to compensate for temperature changes and to permit end movement of the shafts without interference with each other, while transmitting power from the driver to the pump.

3. FIELD ALIGNMENT

The faces of the coupling halves should be spaced far enough apart so that they cannot strike each other when the driver rotor is moved toward the pump. The necessary tools for checking the alignment of a flexible coupling are a straight edge and a taper gauge or a set of feeler gauges.

NOTE: In most cases where extreme accuracy is necessary, a dial indicator may be used to align coupling. Angular alignment check is made by inserting a taper gauge or feelers between the coupling faces at 90-degree intervals around the coupling. The unit will be in angular alignment when the coupling faces are exactly the same distance apart at all points. (See Figure 3).

Parallel alignment check is made by placing a straight edge across both coupling rims at the top, bottom and at both sides. The unit will be in parallel alignment when the straight edge rests evenly on the coupling rim at all positions. Allowance may be necessary for temperature changes and for coupling halves that are not of the same outside diameter. Care must be taken to have the straight edge parallel to the axis of the shafts. Correction for Angular and Parallel Misalignment is made by adjusting the shims under the driver. After each change, it is necessary to recheck the alignment of the coupling halves, as adjustment in one direction may disturb adjustments already made in another direction.

The permissible amount of coupling misalignment will vary with the type of pump and driver, but should be limited to approximately .002 inches per inch of shaft diameter when final adjustment is made. When the units are lined up cold, it is necessary to make allowance for the vertical rise of the driver caused by heating when in operation. When the preliminary alignment has been completed the foundation, bolts should be tightened evenly, but not too firmly.

4. GROUTING

Grouting compensates for unevenness in the foundation and prevents vibration and shifting after mounting is complete. Build a form around the baseplate to contain the grout, and sprinkle area with water to obtain a good bond. The base should be completely filled with a good quality, non-shrinking grout. The usual mixture for grouting is one part Portland cement and two parts sand with sufficient water to flow freely. It is also desirable to grout the leveling pieces, shims or wedges in place. Foundation bolts should be fully tightened when grout has hardened, usually about 48 hours after pouring.

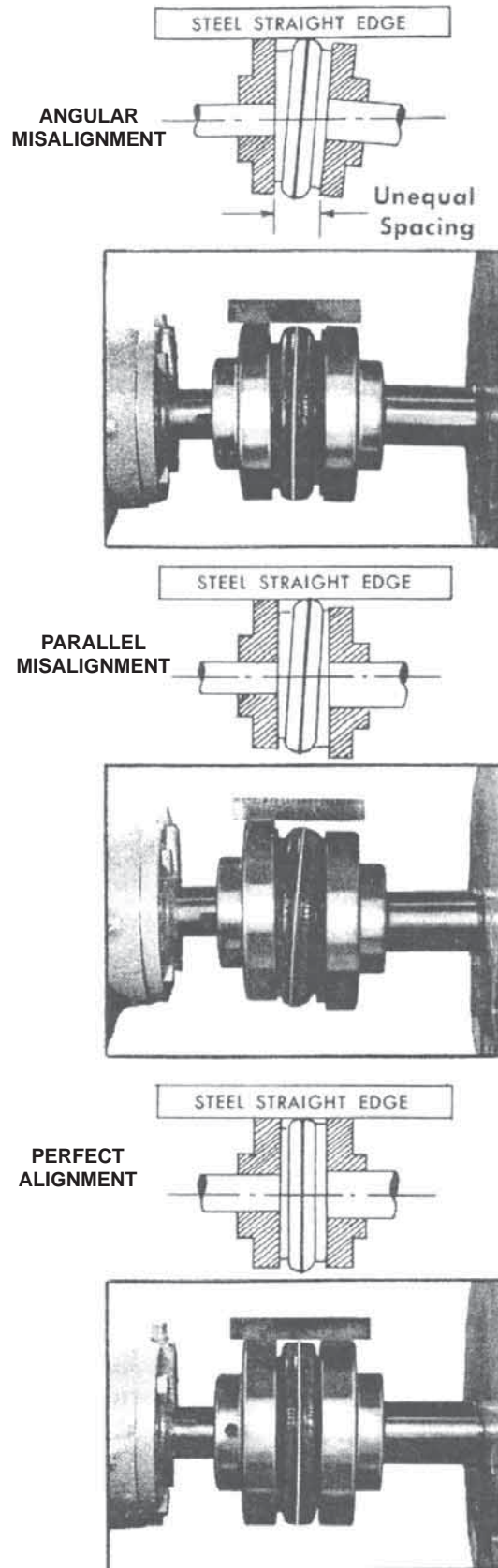

Figure 3

VERTICAL SPLIT CASE COUPLING ALIGNMENT INSTRUCTIONS

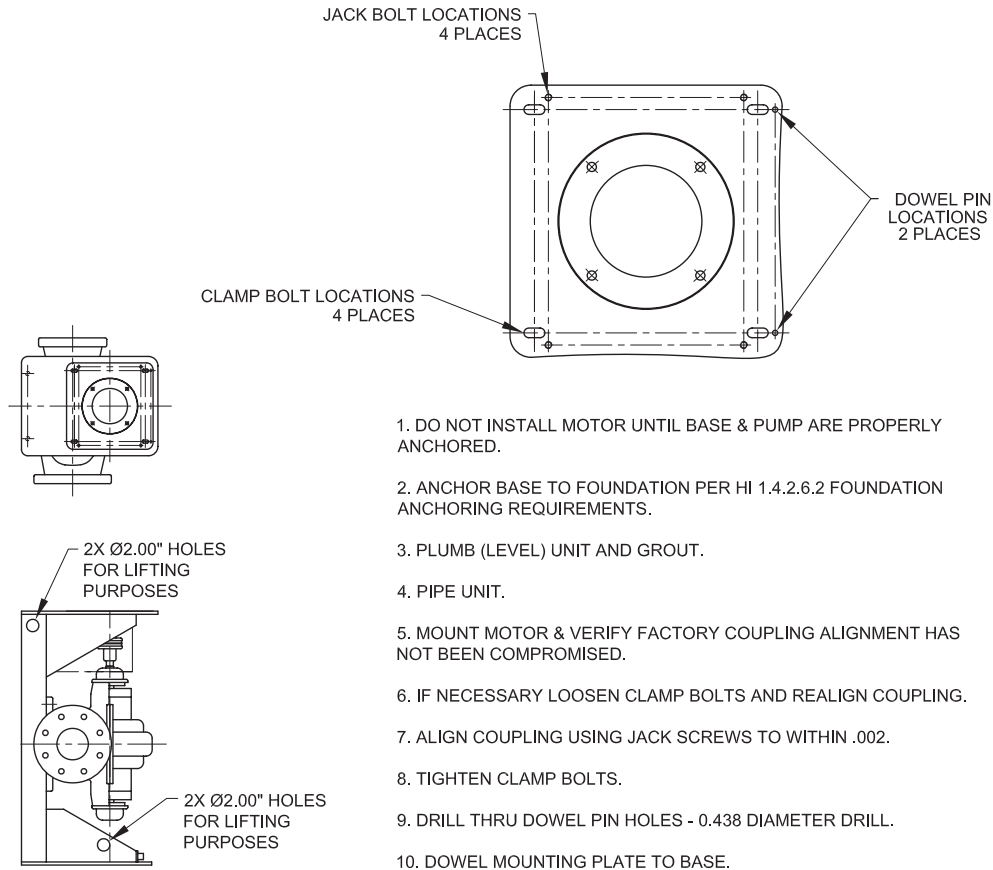

FIGURE 4

5. SUCTION PIPING:

The illustrations on page 9 are offered as a help in avoiding errors frequently made in suction piping, such as abrupt changes in pipe size, the use of concentric reducer, and the placing of an elbow in the horizontal plane next to the suction nozzle of a double suction type of pump, etc.

The following are of equal importance and should be carefully observed:

- A. Never use pipe of a smaller size than that for which the pump is fitted. Almost invariably, it is necessary to use one pipe size larger, and sometimes several sizes larger in order to avoid excessive frictional loss with a resultant prohibitory high working suction lift. Select the size pipe necessary so that when the frictional loss is added to the actual static suction lift, the total suction lift will not exceed 15 to 18 ft. When centrifugal pumps are subjected to a higher suction lift, they are likely to fall short of capacity, unless specifically ordered for an abnormal suction condition.
- B. The suction pipe, from the source of water supply, should be laid with a gradual incline, not on a level, toward the pump, with the highest point in the line at the pump suction connection. If the pipe is level and if there are any high points in the line which will form air pockets, it is sometimes difficult to secure proper priming.
- C. If conditions require the use of a foot valve and strainer, the area of the foot valve should be from 1/2 to 2 times the area of the suction pipe, and the strainer should have a free-opening area equal to 3 to 4 times the area of suction pipe. Otherwise excessive frictional loss will result.
- D. If a gate valve is used on the suction line to a pump operating under a suction lift, the valve stem should be placed in a horizontal plane, or preferably in a vertical, downward position in order to avoid a possible air leak.

- E. The end of the suction pipe should always be submerged from 18" to 4 to 5 ft., depending upon the size of pump and the entrance velocity. If only limited submergence can be had, the end of pipe should be belled or flared. A board floating on the surface of water surrounding the suction pipe will even be helpful against the formation of a vortex permitting air to enter the suction pipe.
- F. Especially with pumps operating under high suction lift, the suction piping should be tested thoroughly against air leaks. A small volume of air will materially reduce the capacity of pump, and a larger volume will frequently unprime the pump.
- G. Installations which will be subjected to considerable temperature variation should be provided with some means for compensating for expansion and contraction. A 50° temperature change means an expansion or contraction of approximately 3/8" in a pipe line of 100 ft. length. This will result in distortion and misalignment of pump, and sometimes actual breakage.
- H. The pipe should not be pulled into position by drawing down on the flange bolts. The pipe should meet the pump and the pump should not be required to meet the pipe. All piping should be supported independently of the pump. Pumps are not designed for carrying heavy loads imposed by piping and its contents.
- I. If other than cold water is to be handled, refer to table on page 6 for limit of suction lift and/or amount of positive suction head, sometimes required in order to avoid vaporization.
- J. In making installation, guard against the possibility of foreign material such as nails, bolts or pieces of waste being left in the line, likely to lodge in the impeller and cause loss of capacity.
- K. When the suction supply is taken from a tank or sump, incoming water should never be allowed to fall from above the water level near the end of suction pipe. This will carry air down into the suction pipe.

SUCTION DIFFUSER FEATURES:

- Reduces both space and installation costs by replacing an extended entry pipe, a long radius elbow and a strainer.
- Disposable fine mesh start-up strainer provided on all models, guarantees a clean system.
- Steel stabilizing vanes ensure smooth flow into the pump.
- Drain/Purge plugs furnished to routinely remove foreign particles and protect pump and other system

components.

- Optional pressure tap allows monitoring of strainer condition.
- Blowdown tapping supplied to protect pump seals from drainage by foreign particles.

SUCTION DIFFUSER INSTALLATION:

1. Provide for distance "L2" (see Suction Diffuser Catalog page for illustration and "L2" dimension). "L2" represents distance necessary for removal of strainer and stabilizing vanes.
2. Mount standard I.D. support leg and foot to pad cast-on body of suction diffuser.
3. After piping and initial circulation are complete, remove fine mesh start-up strainer.
4. If optional pressure tap is provided, a gauge can then be connected to both the pump suction and the Suction Diffuser's schrader valve. An increase in pressure drop will indicate when the strainer may require cleaning.

SUCTION DIFFUSER MAINTENANCE:

It is recommended that the stabilizing vanes be periodically inspected and the permanent strainer be periodically cleaned. This will ensure smooth flow into the pump and avoid damage to the pump components.

6. DISCHARGE PIPE:

The discharge pipe should never be of a smaller size than that for which the pump is fitted and, in most cases, should be one and sometimes two sizes larger in order to avoid excessive frictional loss. Avoid sudden or abrupt changes in pipe sizes which cause shock or frictional losses. Use increasers of the concentric type. Eccentric increasers are not required for the discharge line.

Gate and check valves should be installed in the line with the check placed between pump and gate valve. A check valve, under most conditions of service, is required as a protection to the pump against excessive surge pressure when a foot valve is used on the suction, as well as for protection against reversed rotation if foot valve is used.

In installations where noise is highly objectionable, such as hospitals, hotels and apartment buildings, the discharge pipe should not be attached to steel work or hollow walls without being insulated properly against vibration. In extreme cases, it is desirable that the discharge line be provided with a flexible connection.

TDV DESIGN AND OPERATION:

The principle of operation for the TDV valve is extremely simple. When in the open position, the clapper swings out of the flow. If the flow stops, the spring allows the clapper to close.

When closing the valve, a final "bumping" action with a wrench gives the final positive seal closure.

TDV MAINTENANCE:

The TDV valve requires no day-to-day maintenance or lubrication, but it is suggested that the valve be operated once a month to assure it is in operable condition.

If at any time it is suspected that the valve is leaking, either in the plug position or as a check, it is possible that foreign particles are trapped between the mating faces of the seal and seat, and are preventing tight seal action. Cycling the valve from full open close causes a jetting action that will wash away foreign particles that may be trapped. Also, cycling the valve will usually squeeze any build-up away from the seat mating faces and allow tight shut-off again.

It is not uncommon to discover that when a TDV valve has been reported leaking in the closed position, that the valve is actually not completely closed. The cam-based design of the TDV valve makes it almost impossible to over-close. The TDV is designed to close at an approximate ninety degree rotation of the plug stem. To close the valve, rotate the stem on quarter turn and tighten.

The TDV wrench is specially suited for the cam-based design of the valve to assure a positive closure. The most satisfactory closure is accomplished by turning the plug to a tight fit and then "bumping" the plug lightly using the TDV wrench. The use of cheater or a handwheel should not be necessary.

If these procedures have been completed and a tight seal is still not apparent, the valve should be disassembled and inspected for damage of the clapper seal and seat face, or for excessive wear of the clapper pin and pin hanger supports.

For balancing procedures, please refer to the TDV Catalog page.

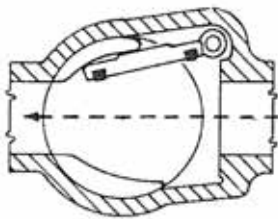

Open Position

With the plug in the open position, the clapper operates as an efficient check valve. The clapper being hinged at an angle provides 90% less dead weight to minimize clapper slam and chatter.

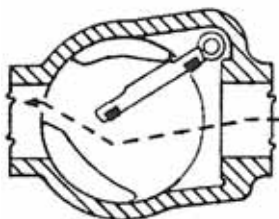

Balancing

The plug holds the clapper at the selected flow requirement for balancing.

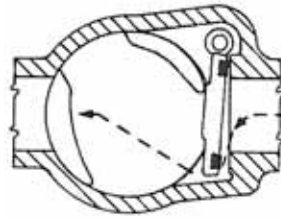

Closed Position

As the plug is rotated toward the closed position, the downstream part closes first. This equalizes the Pressure so the clapper closes with little resistance.

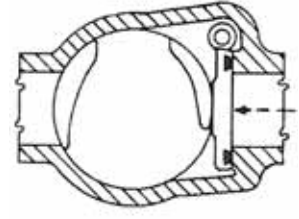

Positive Seal Closure

Final closing is accomplished by the plug camming against the back of the clapper.

REPAIR CLAPPER SEAL:

HVAC TDV valves are equipped with Buna-N clapper seals. If the clapper seal is damaged, they can be replaced by removing the clapper and installing a new seal (see steps 1-3 below).

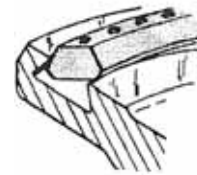

Step 1

Place the outer edge of the seal into the clapper groove as shown.

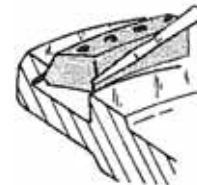

Step 2

Using a blunt screwdriver, force the inside lower edge of the seal into the clapper groove.

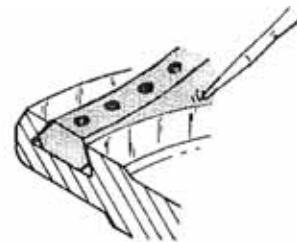

Step 3

As you work the seal in, maintain force on the portion of the seal that has been installed. This will prevent elongation and excessive build-up of closing portion.

REPLACEMENT PROCEDURE:

1. Position clapper firmly against the seat face.
2. Pre-load spring and bind using filament tape (see Figure 5a)
3. Take the clapper pin with the extension screw and insert the pin into the spring and support hangers (see Figure 5b)
4. When holding the clapper firmly against the seat, the clapper pin must move freely into position.
5. Remove the extension screw, replace the clapper pin plug, and cut the filament tape to free the spring.
6. Check the clapper for free movement by opening and closing the clapper by hand.
7. If movement is free, complete the valve assembly.



Figure 5a

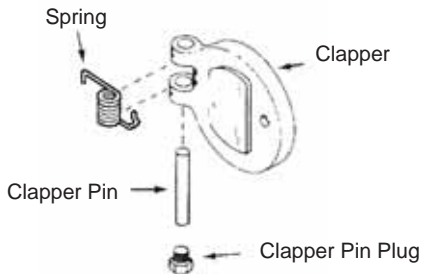

Figure 5b

7. RECIRCULATING ORIFICE:

A pump operating at or near shut-off, as in boiler feed service when there is no demand for steam, all the horsepower of the motor is converted into heating the water in the pump until eventually it turns to steam. To prevent this, a small amount of water should be continuously recirculated from the pump discharge back to the inlet source which, in boiler feed service, is the deaerating heater. Weinman can supply and size an orifice for establishing the required amount of recirculation for any application. It has a bronze body tapped for 1/2" pipe on each end and is fitted with replaceable, stainless steel orifices inserts of various sizes.

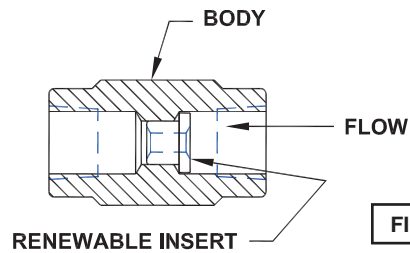

FIGURE 6

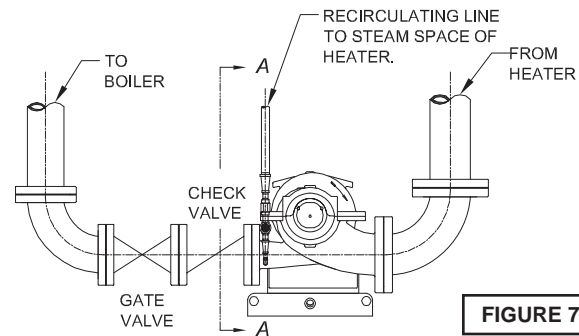
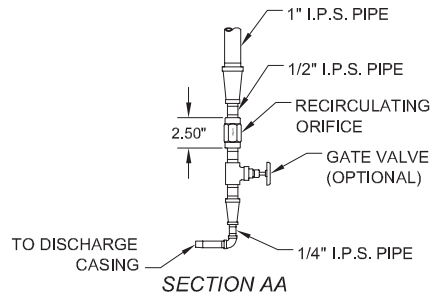

FIGURE 7

8. PRIMING:

Centrifugal pumps of the conventional type must be primed before they will start pumping. With a foot valve on the suction, the simplest method of priming is to fill the suction line and pump, including enough of the discharge line to bring the water level up a foot or two above the top of the casing or volute. The air vents should be left open until water flows several times with no traces of air. The shaft with impeller should be turned several times by hand in order to release air which may be trapped in the impeller.

If a portion of the suction line is laid on a near-level, several minutes may be required for air to find its way to the highest point and escape through the air vents in top of casing. If the pump fails to pump when first started, it should be stopped and after a delay of a few minutes, the air vents should be reopened until a full stream of water, without any trace of air, flows out.

Do not allow a pump, especially a new one, to operate for a long period of time without being properly primed.

9. ROTATION:

The rotation is indicated by arrow on the casing, and the correct rotation of three phase motors should be established before assembling coupling. The pump should not be operated backwards or in reverse rotation.

If the motor operates in the wrong rotation, interchange any two of the lead wires and the opposite rotation will result.

10. STARTING:

For initial starting, the gate valve in the discharge line should be closed, and opened gradually as the motor approaches full speed, usually in from five to ten seconds. After the pump has once been in operation so that the discharge line has been completely filled, it is then unnecessary to close the gate valve in starting.

11. STUFFING BOX PACKING:

After starting the pump, adjust gland nuts evenly until leakage is a stream about the size of a pencil lead. This amount of leakage is required to provide cooling, lubrication and to avoid rapid wear of shaft sleeves. When packing becomes so worn that gland is fully entered and can no longer compress the packing, one ring of packing may be added. After further wear however, the box should be repacked by the following procedure:

- A. Clean out all old packing from the box and remove seal cage if pump is so equipped. Note location of sealing water hole in stuffing box and when repacking be sure seal cage is installed opposite the hole. Failure to do this will block the flow of sealing liquid.
- B. Inspect sleeve for wear and if it is scored or grooved it should be replaced.
- C. Fit packing neatly around the shaft with ends fitting in a tight joint.
- D. Force first ring firmly and evenly to the bottom of the box. Dripping rings in oil and graphite will aid running in of the packing.
- E. Insert remaining rings with joints staggered 180° apart. Compress each ring firmly as described above. Rotate shaft by hand each time a ring is inserted to aid in seating packing. If pump is equipped with seal cage, install it opposite sealing water connection.
- F. When the box is full, compress the packing with the gland. Be sure to adjust gland evenly and also be sure that the gland has entered the box at least 1/8". If the packing will not compress enough to allow this amount of gland entrance, removed one ring of packing.
- G. After pump is started, adjust gland nuts so that leakage is as described above. Care should be taken during the first hour of operation to take up on the packing gradually just enough to maintain this amount of leakage. The "breaking in" period of the packing is most important in the satisfactory performance of a stuffing box.

12. CARE OF BALL BEARINGS:

The ball bearings on pump and motor, as shipped from factory, are furnished with sufficient lubricant for from two to three month's operation. Do not add more lubricant when putting the unit in service.

Injury to ball bearing is more likely to result from over-greasing than from under-greasing. The real purpose of lubricant for ball bearings is to form a coating on the highly polished surfaces as a protection against corrosion, rather than for lubrication. An over supply of grease in ball bearings produces heating, due to friction, and causes the grease to ooze out of bearing housing along the shaft, as the bearing becomes warm.

Under usual conditions, ball bearings will reach a temperature of from 10° to 55°F. above surrounding temperature. Unless the bearing temperature reaches 125°F. above surrounding temperature, there is no cause for alarm.

Ball bearings require additional lubricant only two or three times per year, depending upon the continuity of service. Do not use more grease than necessary to fill the bearing housing one-fourth to one-third full.

If bearings are removed from housing for cleaning, use extreme care to see that they are thoroughly dry before being re-installed. Use carbon-tetrachloride, or kerosene to clean bearings. Water or moisture is destructive to all ball bearings.

The particular brand of grease is unimportant, providing it is a lithium base grease, especially if the bearing is used in a location where there is excessive moisture or danger of water getting into the housing.

For temperatures of from 32° to 200°F. at the bearings, the following brands of lubricant are suggested:

13. BEARING LUBRICATION:

A #2 grease is recommended. Use a water resistant, nonfibrous grease. Lithium base greases are excellent and molydisulfide is acceptable. Approximately 1/2 ounce of grease, or a teaspoonful for bearings of small size, and a tablespoonful for larger sizes, is needed each time a bearing is relubricated.

PUMP TROUBLES AND THEIR CAUSES

<p>FAILURE TO PUMP</p> <ol style="list-style-type: none"> 1. Pump not properly primed 2. Wrong direction of rotation 3. Speed too low 4. Total head too high 	<p>PUMP LOSES PRIMING</p> <ol style="list-style-type: none"> 1. Air leaks in suction line 2. Excessive amount of air in water 3. Water seal in stuffing box not functioning 4. Excessive suction lift and pump operating too near shut-off point
<p>REDUCE CAPACITY AND/OR HEAD</p> <ol style="list-style-type: none"> 1. Air pockets or leaks in suction line 2. Clogged impeller 3. Foot-valve strainer too small or clogged 4. Insufficient submergence for suction pipe 5. Excessive suction lift, much over 15 ft. 6. Insufficient positive suction head (for hot water) 7. Total head more than that for which pump is intended 8. Excessively worn impeller and wearing rings 	<p>MECHANICAL TROUBLES AND NOISE</p> <ol style="list-style-type: none"> 1. Misalignment 2. Excessive suction lift or vapor binding (hot water) 3. Bent shaft and/or damaged bearings 4. Suction and discharge piping not properly supported and anchored
<p>RAPID WEAR OF COUPLING CUSHIONS</p> <ol style="list-style-type: none"> 1. Always the result of misalignment or a bent shaft 	<p>OVERLOADED DRIVING UNIT</p> <ol style="list-style-type: none"> 1. Head much lower than that for which pump is designed 2. Speed too high, higher than that contemplated 3. Liquid handled of high specific gravity and greater viscosity than that of water

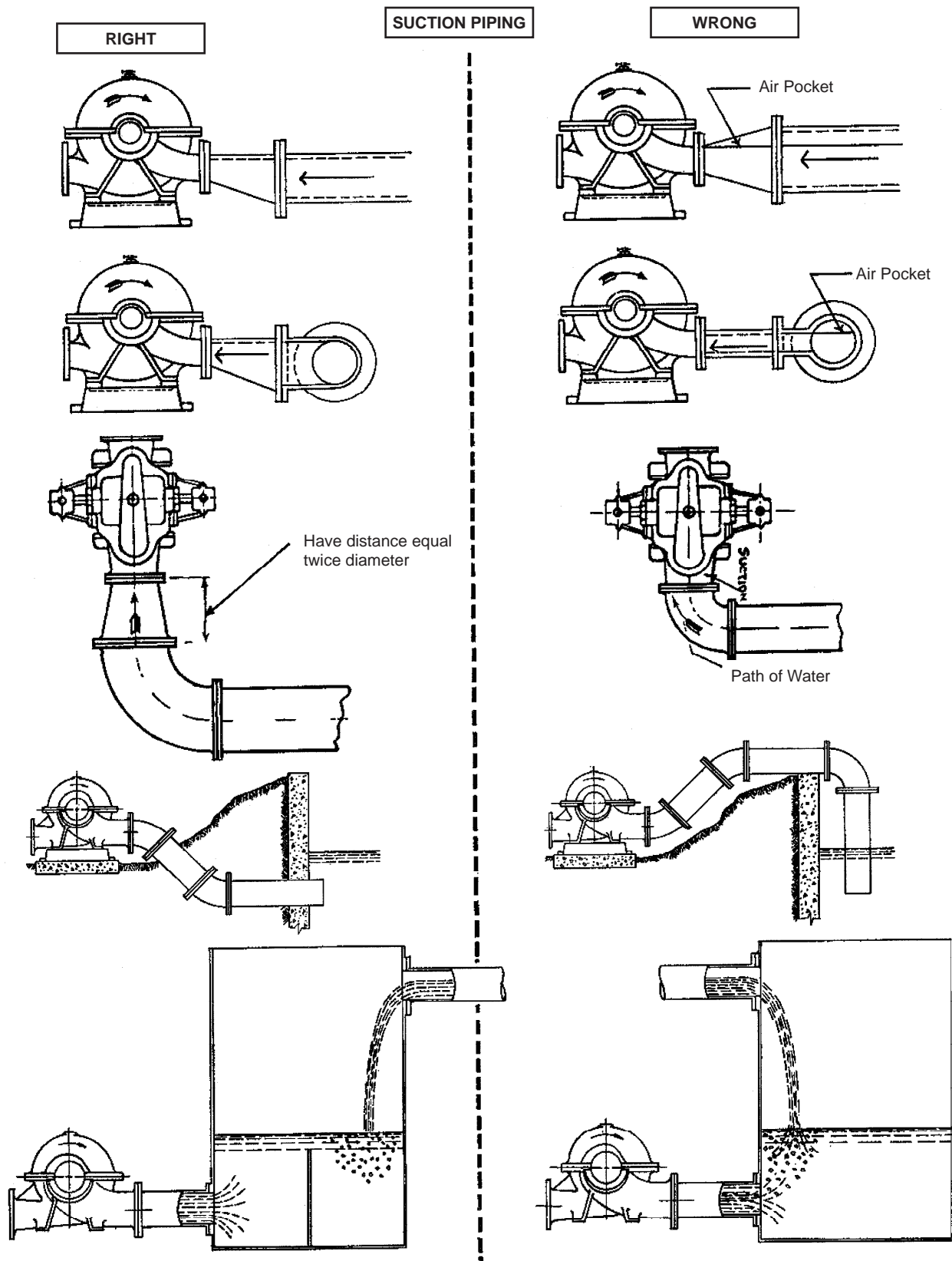

FIGURE 8

TABLES FOR SUCTION LIFT FOR CENTRIFUGAL PUMPS FOR WATER AT DIFFERENT ELEVATIONS AND TEMPERATURES

ATMOSPHERIC PRESSURE, BAROMETER READING AND EQUIVALENT HEAD OF WATER AT DIFFERENT ALTITUDES

ALTITUDE ABOVE SEA LEVEL IN FEET	ATMOSPHERIC PRESSURE POUNDS PER SQ. IN.	BAROMETER READING INCHES OF MERCURY	EQUIVALENT HEAD OF WATER FEET	MAXIMUM PRACTICAL SUCTION LIFT OF PUMPS IN FEET
0	14.7	29.929	33.95	25
1000	14.2	28.8	32.7	23
2000	13.6	27.7	31.6	23
3000	13.1	26.7	30.2	22
4000	12.6	25.7	29.1	21
5000	12.1	24.7	27.9	20
6000	11.7	23.8	27.0	19
7000	11.2	22.9	25.9	19
8000	10.8	22.1	24.9	18
9000	10.4	21.2	24.0	17
10000	10.0	20.4	23.1	16

For Ft. Hd. of liquid divide Ft. Hd. of water by specific gravity of liquid pumped.

NOTE: Barometer in inches multiplied by 0.4908 equals pressure per square inch.

Suction lift is vertical distance from center of pump shaft to water level plus pipe friction and other losses, if any.

SUCTION HEAD REQUIREMENTS WHEN PUMPING HOT WATER

Suction Head Required for both Centrifugal and Reciprocating Pumps when handling hot water at different altitudes.

Minimum Allowable Head in Ft. on Suction	Temperature of Water in Degrees F.									
	120	130	140	150	160	170	180	190	200	210
At sea level	---	---	---	---	0	3	5	7	10	12
At 2,000 alt.	---	---	---	1	3	5	7	10	12	15
At 4,000 alt.	---	0	1	3	5	7	10	12	14	---
At 6,000 alt.	0	1	3	5	7	10	12	14	16	---
At 8,000 alt.	0	3	5	7	9	12	14	16	---	---
At 10,000 alt.	2	4	7	9	11	14	16	18	---	---

PROPERTIES OF WATER AT VARIOUS TEMPERATURES FROM 40° TO 540° F

Temp °F	Temp °C	Specific Volume Cu. Ft./Lb.	Specific Gravity	Wt. in Lb./Cu. Ft.	Vapor Pressure PSI Abs
40	4.4	.01602	1.0013	62.42	0.1217
50	10.0	.01603	1.0006	62.38	0.1781
60	15.6	.01604	1.0000	62.34	0.2563
70	21.1	.01606	0.9987	62.27	0.3631
80	26.7	.01608	0.9975	62.19	0.5069
90	32.2	.01610	0.9963	62.11	0.6982
100	37.8	.01613	0.9944	62.00	0.9492
120	48.9	.01620	0.9901	61.73	1.692
140	60.0	.01629	0.9846	61.39	2.889
160	71.1	.01639	0.9786	61.01	4.741
180	82.2	.01651	0.9715	60.57	7.510
200	93.3	.01663	0.9645	60.13	11.526
212	100.0	.01672	0.9593	59.81	14.696
220	104.4	.01677	0.9565	59.63	17.186
240	115.6	.01692	0.9480	59.10	24.97
260	126.7	.01709	0.9386	58.51	35.43
280	137.8	.01726	0.9293	58.00	49.20
300	148.9	.01745	0.9192	57.31	67.01
320	160.0	.01765	0.9088	56.66	89.66
340	171.1	.01787	0.8976	55.96	118.01
360	182.2	.01811	0.8857	55.22	153.04
380	193.3	.01836	0.8736	54.47	195.77
400	204.4	.01864	0.8605	53.65	247.31
420	215.6	.01894	0.8469	52.80	308.83
440	226.7	.01926	0.8328	51.92	381.59
460	237.8	.0196	0.8183	51.02	466.9
480	248.9	.0200	0.8020	50.00	566.1
500	260.0	.0204	0.7863	49.02	680.8
520	271.1	.0209	0.7674	47.85	812.4
540	282.2	.0215	0.7460	46.51	962.5

Computed from Keenan & Keyes' Steam Table.

BARNES®

BARNES®
PRESSURE **PS** SYSTEMS®



burks®

WEINMAN®

DEMING®

PROSSER®

Limited 24 Month Warranty

Crane Pumps & Systems warrants that products of our manufacture will be free of defects in material and workmanship under normal use and service for twenty-four (24) months after manufacture date, when installed and maintained in accordance with our instructions. This warranty gives you specific legal rights, and there may also be other rights which vary from state to state. In the event the product is covered by the Federal Consumer Product Warranties Law (1) the duration of any implied warranties associated with the product by virtue of said law is limited to the same duration as stated herein, (2) this warranty is a LIMITED WARRANTY, and (3) no claims of any nature whatsoever shall be made against us, until the ultimate consumer, his successor, or assigns, notifies us in writing of the defect, and delivers the product and/or defective part(s) freight prepaid to our factory or nearest authorized service station. Some states do not allow limitations on how long an implied warranty lasts, so the above limitation may not apply. **THE SOLE AND EXCLUSIVE REMEDY FOR BREACH OF ANY AND ALL WARRANTIES WITH RESPECT TO ANY PRODUCT SHALL BE TO REPLACE OR REPAIR AT OUR ELECTION, F.O.B. POINT OF MANUFACTURE OR AUTHORIZED REPAIR STATION, SUCH PRODUCTS AND/OR PARTS AS PROVEN DEFECTIVE. THERE SHALL BE NO FURTHER LIABILITY, WHETHER BASED ON WARRANTY, NEGLIGENCE OR OTHERWISE.** Unless expressly stated otherwise, guarantees in the nature of performance specifications furnished in addition to the foregoing material and workmanship warranties on a product manufactured by us, if any, are subject to laboratory tests corrected for field performance. Any additional guarantees, in the nature of performance specifications must be in writing and such writing must be signed by our authorized representative. Due to inaccuracies in field testing if a conflict arises between the results of field testing conducted by or for user, and laboratory tests corrected for field performance, the latter shall control. **RECOMMENDATIONS FOR SPECIAL APPLICATIONS OR THOSE RESULTING FROM SYSTEMS ANALYSES AND EVALUATIONS WE CONDUCT WILL BE BASED ON OUR BEST AVAILABLE EXPERIENCE AND PUBLISHED INDUSTRY INFORMATION. SUCH RECOMMENDATIONS DO NOT CONSTITUTE A WARRANTY OF SATISFACTORY PERFORMANCE AND NO SUCH WARRANTY IS GIVEN.**

This warranty shall not apply when damage is caused by (a) improper installation, (b) improper voltage (c) lightning (d) excessive sand or other abrasive material (e) scale or corrosion build-up due to excessive chemical content. Any modification of the original equipment will also void the warranty. We will not be responsible for loss, damage or labor cost due to interruption of service caused by defective parts. Neither will we accept charges incurred by others without our prior written approval.

This warranty is void if our inspection reveals the product was used in a manner inconsistent with normal industry practice and/or our specific recommendations. The purchaser is responsible for communication of all necessary information regarding the application and use of the product. **UNDER NO CIRCUMSTANCES WILL WE BE RESPONSIBLE FOR ANY OTHER DIRECT OR CONSEQUENTIAL DAMAGES, INCLUDING BUT NOT LIMITED TO TRAVEL EXPENSES, RENTED EQUIPMENT, OUTSIDE CONTRACTOR FEES, UNAUTHORIZED REPAIR SHOP EXPENSES, LOST PROFITS, LOST INCOME, LABOR CHARGES, DELAYS IN PRODUCTION, IDLE PRODUCTION, WHICH DAMAGES ARE CAUSED BY ANY DEFECTS IN MATERIAL AND/OR WORKMANSHIP AND/OR DAMAGE OR DELAYS IN SHIPMENT. THIS WARRANTY IS EXPRESSLY IN LIEU OF ANY OTHER EXPRESS OR IMPLIED WARRANTY, INCLUDING ANY WARRANTY OF MERCHANTABILITY OR FITNESS FOR A PARTICULAR PURPOSE.**

No rights extended under this warranty shall be assigned to any other person, whether by operation of law or otherwise, without our prior written approval.

CRANE[®]

A Crane Co. Company

PUMPS & SYSTEMS

420 Third Street
Piqua, Ohio 45356
Phone: (937) 778-8947
Fax: (937) 773-7157
www.cranepumps.com

83 West Drive, Brampton
Ontario, Canada L6T 2J6
Phone: (905) 457-6223
Fax: (905) 457-2650

**IMPORTANT!
WARRANTY REGISTRATION**

Your product is covered by the enclosed Warranty.
To complete the Warranty Registration Form go to:

<http://www.cranepumps.com/ProductRegistration/>

If you have a claim under the provision of the warranty, contact your local
Crane Pumps & Systems, Inc. Distributor.

RETURNED GOODS

**RETURN OF MERCHANDISE REQUIRES A "RETURNED GOODS AUTHORIZATION".
CONTACT YOUR LOCAL CRANE PUMPS & SYSTEMS, INC. DISTRIBUTOR.**



**Products Returned Must Be Cleaned, Sanitized,
Or Decontaminated As Necessary Prior To Shipment,
To Insure That Employees Will Not Be Exposed To Health
Hazards In Handling Said Material. All Applicable Laws
And Regulations Shall Apply.**



A Crane Co. Company

PUMPS & SYSTEMS

START-UP REPORT

General Information

Pump Owner's Name: _____
 Address: _____
 Location of Installation: _____
 Contact Person: _____ Phone: _____
 Purchased From: _____

Nameplate Data

Pump Model #: _____ Serial #: _____
 Part #: _____ Impeller Diameter: _____
 Voltage: _____ Phase: _____ Ø Hertz: _____ Horsepower: _____
 Full Load Amps: _____ Service Factor Amps: _____
 Motor Manufacturer: _____

Controls

Control panel manufacturer: _____
 Model/Part number: _____
 Number of pumps operated by control panel: _____
 Short circuit protection? YES___ NO___ Type: _____
 Number and size of short circuit device(s): _____ Amp rating: _____
 Overload Type: _____ Size: _____ Amp rating: _____
 Do protection devices comply with pump and motor Amp rating? YES___ NO___
 Are all electrical and panel entry connections tight? YES___ NO___
 Is the interior of the panel dry? YES___ NO___
 Liquid level Control Brand and Model: _____

Pre-Startup

All Pumps

Type of equipment: NEW___ REBUILT___ USED___
 Condition of equipment at Start-Up: DRY___ WET___ MUDDY___
 Was Equipment Stored? YES___ NO___ Length of Storage: _____
 Liquid being pumped: _____ Liquid Temperature: _____
 Supply Voltage/Phase/Frequency matches nameplate? YES___ NO___
 Shaft turns freely? YES___ NO___
 Direction of rotation verified for 3Ø motors? YES___ NO___
 Debris in piping or wet well? YES___ NO___
 Debris removed in your presence? YES___ NO___
 Pump case/wet well filled with liquid before startup? YES___ NO___
 Is piping properly supported? YES___ NO___

Non-Submersible Pumps

Is base plate properly installed / grouted? YES___ NO___ N/A___
 Coupling Alignment Verified per I&O Manual? YES___ NO___ N/A___
 Grease Cup/Oil Reservoir Level checked? YES___ NO___ N/A___

Submersible Pumps

Resistance of cable and pump motor (measured at pump control):

Red-Black: _____ Ohms(Ω) Red-White: _____ Ohms(Ω) White-Black: _____ Ohms(Ω)

Resistance of Ground Circuit between Control Panel and outside of pump: _____ Ohms(Ω)

MEG Ohms check of insulation:

Red to Ground: _____ White to Ground: _____ Black to Ground: _____

Operational Checks

Is there noise or vibration present? YES___ NO___ Source of noise/vibration: _____

Does check valve operate properly? YES___ NO___ N/A___

Is system free of leaks? YES___ NO___ Leaks at: _____

Does system appear to operate at design flow rate? YES___ NO___

Nominal Voltage: _____ Phase: 1Ø 3Ø (select one)

Voltage Reading at panel connection, Pump OFF: L1, L2 _____ L2, L3 _____ L1, L3 _____

Voltage Reading at panel connection, Pump ON: L1, L2 _____ L2, L3 _____ L1, L3 _____

Amperage Draw, Pump ON: L1 _____ L2 _____ L3 _____

Submersible Pumps

Are BAF and guide rails level / plumb? YES___ NO___

Is pump seated on discharge properly? YES___ NO___

Are level controls installed away from turbulence? YES___ NO___

Is level control operating properly? YES___ NO___

Is pump fully submerged during operation? YES___ NO___

Follow up/Corrective Action Required

YES___ NO___

Additional Comments:

Startup performed by: _____ Date: _____

Present at Start-Up

() Engineer: _____ () Operator: _____

() Contactor: _____ () Other: _____

All parties should retain a copy of this report for future trouble shooting/reference



A Crane Co. Company

PUMPS & SYSTEMS

420 Third Street
Piqua, Ohio 45356
Phone: (937) 778-8947
Fax: (937) 773-7157
www.cranepumps.com

83 West Drive, Brampton
Ontario, Canada L6T 2J6
Phone: (905) 457-6223
Fax: (905) 457-2650