

### Multi-Stage Split Case Pumps - Horizontally Mounted

<b>PUMP NO.</b>	<b>PUMP:</b>	<b>MOTOR:</b>	<b>VOLTS:</b>
<b>FOR:</b>	<b>TDH:</b>	<b>HP:</b>	<b>HZ:</b>
<b>CERT. BY:</b>	<b>GPM:</b>	<b>RPM:</b>	<b>FRAME:</b>
<b>DATE:</b>	<b>ROTATION:</b>	<b>PHASE:</b>	
	<b>FIGURE NO:</b>	<b>ENCLOSURE:</b>	

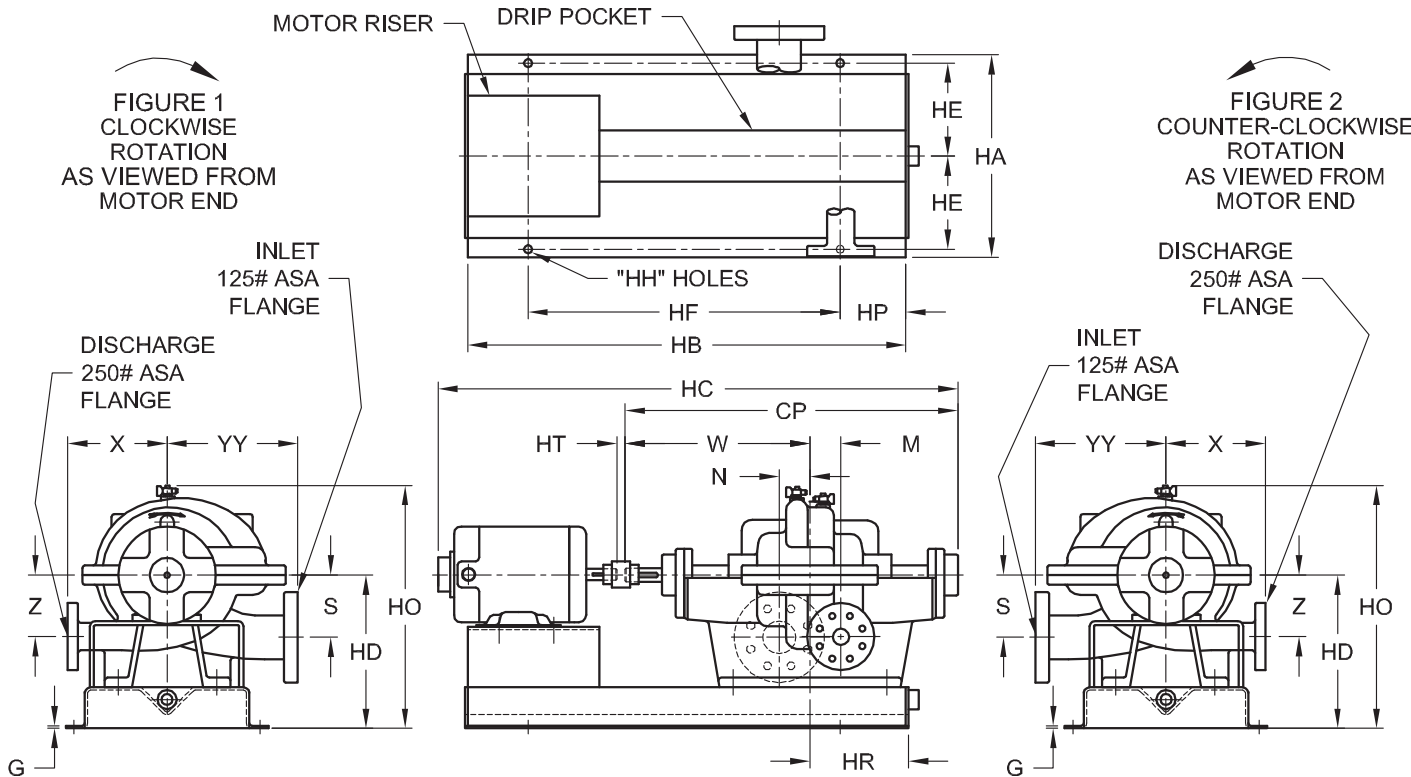

DIMENSIONS SHOWN ARE FOR STANDARD "DRIP TROUGH" BASE. CONSULT FACTORY FOR "DRIP PAN" BASE DIMENSIONS.

#### DIMENSIONS IN INCHES

MOTOR FRAME	HA	HB	HC		HD	HE	HF	HG	HH	HM	HO	HP	HR	HT
			*	**										
145T	18.50	40.50	43.50	46.75	13.75	8.50	28.50	0.25	0.75	17.38	22.50	6.00	9.00	.63
182T	18.50	40.50	44.88	48.13	13.75	8.50	28.50	0.25	0.75	19.63	22.50	6.00	9.00	.63
184T	18.50	40.50	45.88	49.13	13.75	8.50	28.50	0.25	0.75	19.63	22.50	6.00	9.00	.63
213T	18.50	45.50	48.38	51.63	13.75	8.50	33.50	0.25	0.75	19.50	22.50	6.00	9.00	.25
215T	18.50	45.50	49.88	53.13	13.75	8.50	33.50	0.25	0.75	19.50	22.50	6.00	9.00	.25
254T	18.50	45.50	52.75	--	13.75	8.50	33.50	0.25	0.75	20.63	22.50	6.00	9.00	.25
254T	20.50	54.50	--	56.00	13.75	9.50	42.50	0.25	0.75	20.63	22.50	6.00	9.00	.25
256T	18.50	45.50	54.50	--	13.75	8.50	33.50	0.25	0.75	20.63	22.50	6.00	9.00	.25
256T	20.50	54.50	--	57.75	13.75	9.50	42.50	0.25	0.75	20.63	22.50	6.00	9.00	.25
284TS	20.50	54.50	54.13	57.38	13.75	9.50	42.50	0.25	0.75	21.38	22.50	6.00	9.00	.25
286TS	20.50	54.50	55.88	58.88	13.75	9.50	42.50	0.25	0.75	21.38	22.50	6.00	9.00	.25
324TS	20.50	54.75	56.63	59.88	14.00	9.50	42.50	0.38	0.75	22.50	22.75	6.13	9.00	.25
326TS	20.50	54.75	58.13	61.38	14.00	9.50	42.50	0.38	0.75	22.50	22.75	6.13	9.00	.25
364TS	24.50	54.50	62.38	65.63	13.75	11.50	42.50	0.31	0.75	23.50	22.50	6.00	9.00	.25

#### DIMENSIONS IN INCHES

PUMP	TYPE	DISCH. (INCH)	INLET (INCH)	CP	M	N	S	U	W	X	YY	Z	KEYWAY (INCH)
1.5JD*	STANDARD BEARINGS	1.5	3	30.00	1.19	2.81	5.63	1.13	16.25	9.00	11.75	5.63	.25 x .13
1.5JD*	WATER COOLED THRUST BEARINGS	1.5	3	30.63	1.19	2.81	5.63	1.13	16.25	9.00	11.75	5.63	.25 x .13
1.5JD**	WATER COOLED RADIAL & THRUST BEARINGS	1.5	3	33.00	1.19	2.81	5.63	1.13	18.63	9.00	11.75	5.63	.25 x .13

# 1.5" - 2 Stage Type "JD"

With Steel Baseplates

Metric (mm)

# WEINMAN®

www.cranepumps.com

## Multi-Stage Split Case Pumps - Horizontally Mounted

PUMP NO.	PUMP: TDH: GPM: ROTATION: FIGURE NO:	MOTOR: HP: RPM: PHASE: ENCLOSURE:	VOLTS: HZ: FRAME:
FOR:	DATE:		
CERT. BY:			

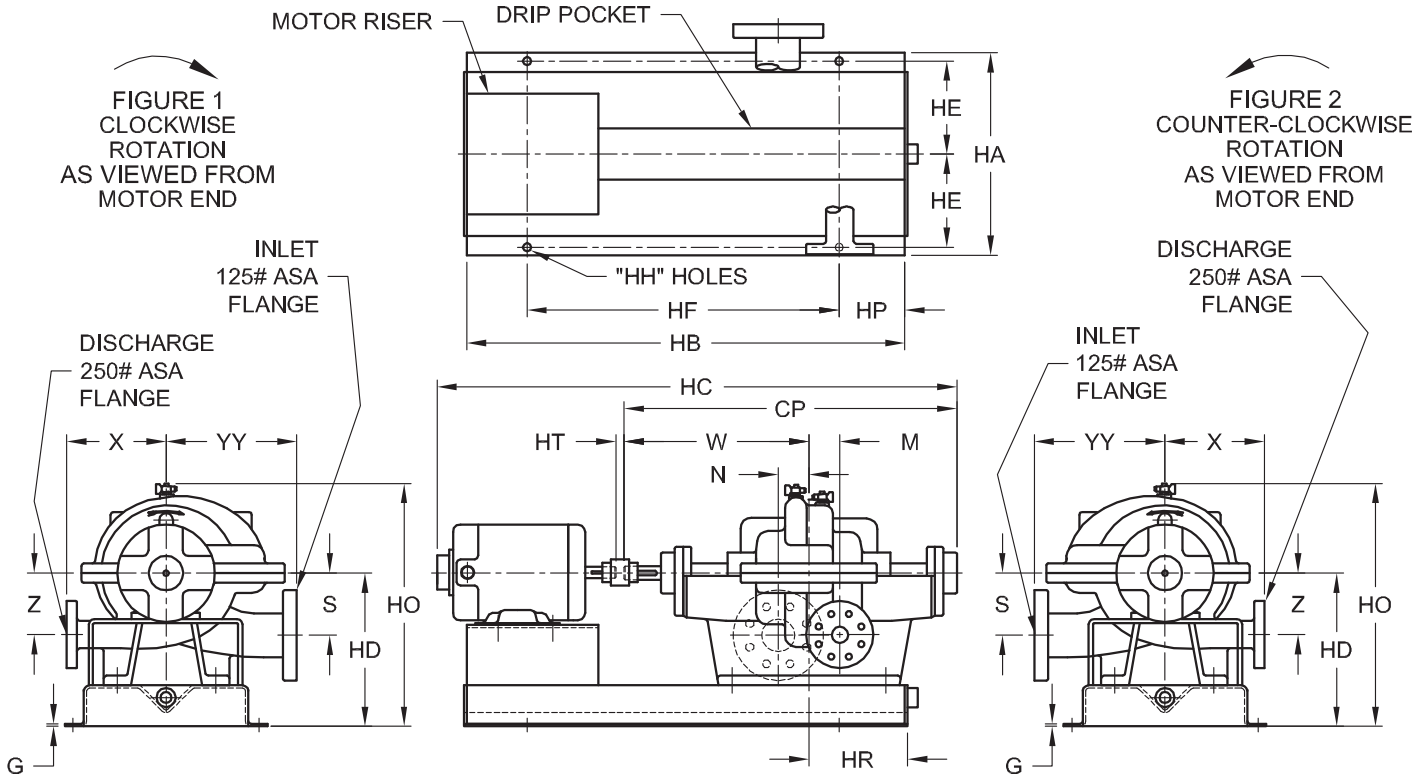

DIMENSIONS SHOWN ARE FOR STANDARD "DRIP TROUGH" BASE. CONSULT FACTORY FOR "DRIP PAN" BASE DIMENSIONS.

### DIMENSIONS IN MILLIMETERS

MOTOR FRAME	HA	HB	HC		HD	HE	HF	HG	HH	HM	HO	HP	HR	HT
			*	**										
145T	470	1029	1105	1187	349	216	724	6	19	441	572	152	229	16
182T	470	1029	1140	1222	349	216	724	6	19	498	572	152	229	16
184T	470	1029	1165	1248	349	216	724	6	19	498	572	152	229	16
213T	470	1156	1229	1311	349	216	851	6	19	495	572	152	229	6
215T	470	1156	1267	1349	349	216	851	6	19	495	572	152	229	6
254T	470	1156	1340	--	349	216	851	6	19	524	572	152	229	6
254T	521	1384	--	1422	349	241	1080	6	19	524	572	152	229	6
256T	470	1156	1384	--	349	216	851	6	19	524	572	152	229	6
256T	521	1384	--	1467	349	241	1080	6	19	524	572	152	229	6
284TS	521	1384	1375	1457	349	241	1080	6	19	543	572	152	229	6
286TS	521	1384	1419	1495	349	241	1080	6	19	543	572	152	229	6
324TS	521	1391	1438	1521	356	241	1080	10	19	572	578	156	229	6
326TS	521	1391	1476	1559	356	241	1080	10	19	572	578	156	229	6
364TS	622	1384	1584	1667	349	292	1080	8	19	597	572	152	229	6

### DIMENSIONS IN MILLIMETERS

PUMP	TYPE	DISCH. (INCH)	INLET (INCH)	CP	M	N	S	U	W	X	YY	Z	KEYWAY (INCH)
1.5JD*	STANDARD BEARINGS	1.5	3	762	30	71	143	29	413	229	298	143	.25 x .13
1.5JD*	WATER COOLED THRUST BEARINGS	1.5	3	778	30	71	143	29	413	229	298	143	.25 x .13
1.5JD**	WATER COOLED RADIAL & THRUST BEARINGS	1.5	3	838	30	71	143	29	473	229	298	143	.25 x .13

SECTION 1310  
PAGE 14  
DATE 5/18

# CRANE®

A Crane Co. Company

## PUMPS & SYSTEMS

USA: (937) 778-8947 • Canada: (905) 457-6223 • International: (937) 615-3598