

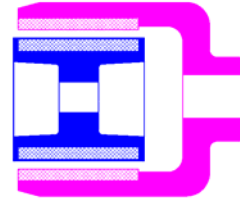

## **Mag-Drive Engineering Data Pack**



### **Contents:**

#### **Series Description**

Page 2-3: Mag-Drive Series Description

Page 4: Model Number System

#### **ML Series Pump Mounting Dimensions**

Page 5: Pump Mounting Dimensions (ML0I & ML1I & ML2I)

#### **MC Series Pump Mounting Dimensions**

Page 6: Pump Mounting Dimensions (MC2I & MC3I)

Page 7: Pump Mounting Dimensions (MC4I & MC5I)

Page 8: Pump Mounting Dimensions (MC6I)

#### **ML & MC General Pump Information**

Page 9: ML Pump Performance Data

Page 10-11: MC Pump Performance Data

Page 12: ML & MC Temperature Limits

Page 13: ML & MC Pump Materials of Construction

Page 14: ML NPSHr Data

Page 15: MC NPSHr Data

#### **GlobalGear<sup>®</sup> MG Pump Mounting Dimensions**

Page 16: Pump Mounting Dimensions (MG015I, MG015S, MG030I & MG030S)

Page 17: Pump Mounting Dimensions (MG080I & MG080S)

#### **MG General Pump Information**

Page 18-19: MG Pump Performance Data

Page 20: MG Temperature Limits

Page 21: MG Pump Materials of Construction

Page 22: MG NPSHr Data

Page 23: MG Flange Ratings (Cast Iron)

Page 24: MG Flange Ratings (Stainless Steel)



## Mag-Drive Series Description

Tuthill Pump Group has been a leader in the development and manufacture of positive displacement pumps since 1927. Tuthill Pump – Concord Operation, a sister division, has been at the forefront in the development of miniature magnetically coupled gear pumps since 1977. From this vast knowledge in both magnet and pump technology has come the ML, MC & MG series of magnetically coupled sealless pumps.

The ML, MC & MG series of pumps combines the time proven reliability of internal gear design with the advantages of magnetically coupled sealless construction. These pumps incorporate Samarium Cobalt magnets for a broader temperature range compared to the more standard Neodymium magnets found in the industry. They are designed for hazardous or toxic pumping applications where fluid leakage cannot be tolerated, incorporating both full encapsulation to protect the inner magnet from the process fluid and a unique fluid flow path to provide cooling for the inner magnet containment area.

The ML series pumps have capacities to 6 G.P.M. and differential pressures up to 500 P.S.I. with a maximum pressure rating up to 500 P.S.I. The ML series Samarium Cobalt magnets are rated to 5 ft-lbs. of torque. This series is designed to be adapter mounted for direct coupling to a 56C frame motor.

The MC series pumps have capacities to 84 G.P.M. and differential pressures up to 150 P.S.I. with a maximum pressure rating of 300 P.S.I. The MC series Samarium Cobalt magnets for the MC2I, MC3I & MC4I are rated to 16 ft-lbs., and the MC5I & MC6I are rated to 60 ft-lbs. of torque.

The MG series of pumps have capacities up to 80 G.P.M. and differential pressures up to 200 P.S.I. with a maximum pressure rating of 300 P.S.I. The MG series Samarium Cobalt magnets for the MG015 & MG030 are rated to 16 ft-lbs., and the MG080 magnets are rated to 60 ft-lbs. The MG series also has a patented rotor thrust control feature which improves the life and performance of the pump, and is also used for setting the pump end clearance.

**WARNING**



**WARNING**

The magnets in magnetically coupled pumps create very strong magnetic fields. Special care must be taken with the following:

**Pacemakers** - Magnets can upset the timing of pacemakers. These magnets should be kept away from all pacemakers. Because of the health risks involved the importance of this cannot be overstated.

**Credit Cards** - Magnets can scramble the information on a credit card's magnetic tape.

**Computers, Computer Tapes and Computer Disks** - Magnets can scramble the information on the memory device.

**Watches** - Magnets can affect the workings of traditional mechanical spring driven watches as well as chip and electronically controlled designs.

**Electronic Instruments** - Sensitive electronic instruments and devices may change calibration or be damaged by a powerful magnetic field.

**Explosive Atmosphere** - Rare earth magnets and magnetic materials may create sparks through contact in handling. Never handle rare earth magnets in explosive atmospheres because sparking may ignite the atmosphere.



**TUTHILL  
Pump Group**

12500 South Pulaski Road  
Alsip, Illinois USA 60803  
Tel 708 389-2500 Fax 708 388-0869  
email: tuthillpump@tuthill.com  
www.tuthill.com

**WARNING**



**WARNING**

**DO NOT PLACE HAND OR FINGERS BETWEEN THE HOUSING AND ADAPTER.** The magnets are extremely strong and will attract all metallic objects and can be the source of pinch points. Do not wear watches or other metallic jewelry when working with magnets.



## MG Pump Model Number System



**Pump Series**  
 ML = L Series Mag-Drive  
 MC = C Series Mag-Drive  
 MG = GlobalGear Series  
 Mag-Drive

**Pump Material**  
 I = Iron Pump\*  
 S = Stainless Steel  
 \* ML & MC available in  
 Iron Only

**Serial # Assigned By Big Machines**  
 - Pumps selected by Big Machines  
 Pump Selection Software via  
 customer or Tuthill employee will have  
 a number assigned to a pump. This  
 serial number will be incorporated into  
 the pump model number.

**Pump Size**  
 0 = 0LFD Size Pump  
 1 = 1LFD Size Pump  
 2 = 2LFD Size Pump

2 = 2C Size Pump  
 3 = 3C Size Pump  
 4 = 4C Size Pump  
 5 = 5C Size Pump  
 6 = 6C Size Pump

015 = GG015 Size Pump  
 030 = GG030 Size Pump  
 080 = GG080 Size Pump



## ML01 & ML11 Pump Mounting Dimensions

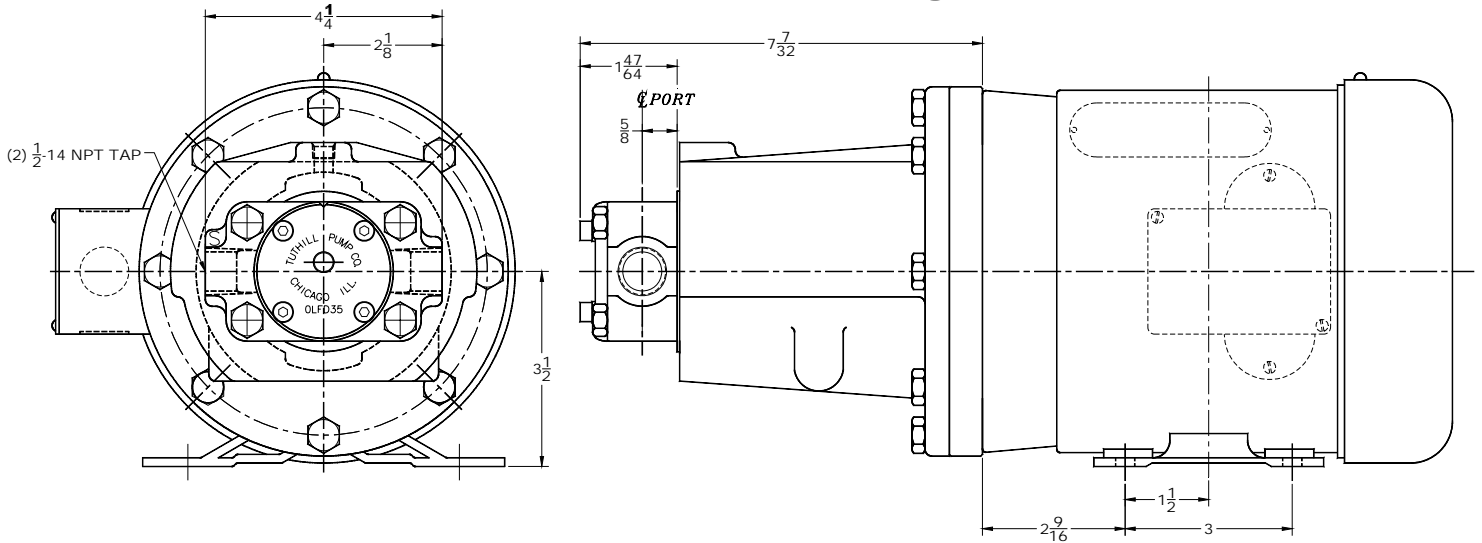

\*Note: NEMA 56C frame motor is required.

## ML21 Pump Mounting Dimensions

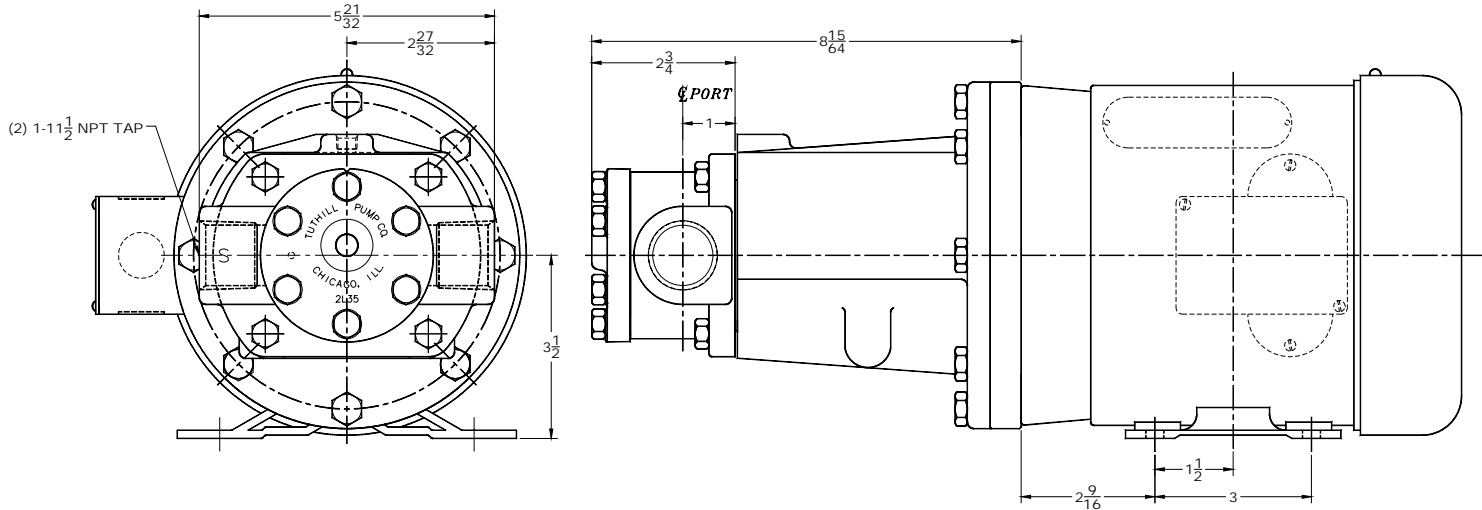

\*Note: NEMA 56C frame motor is required.

## MC2I Pump Mounting Dimensions

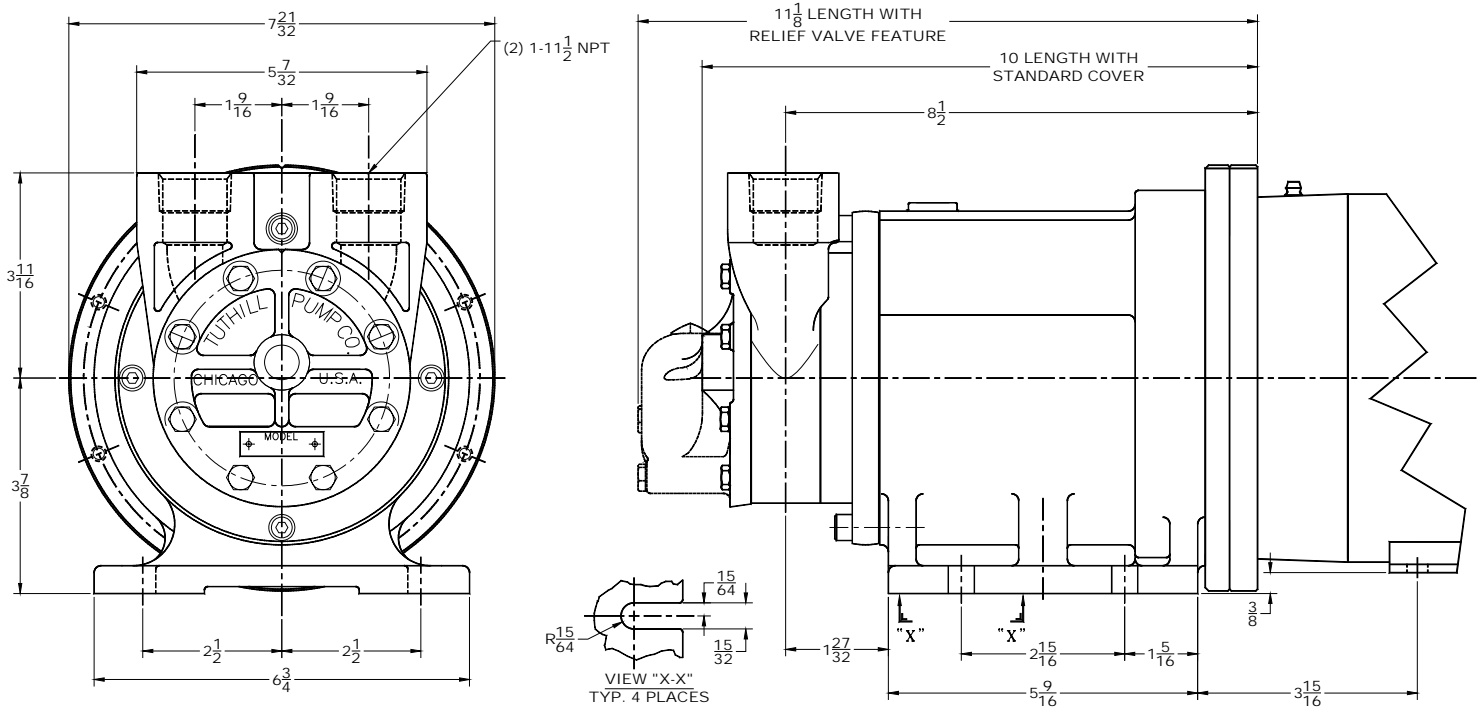

\*Note: Pump shown coupled to 145TC frame motor.

## MC3I Pump Mounting Dimensions

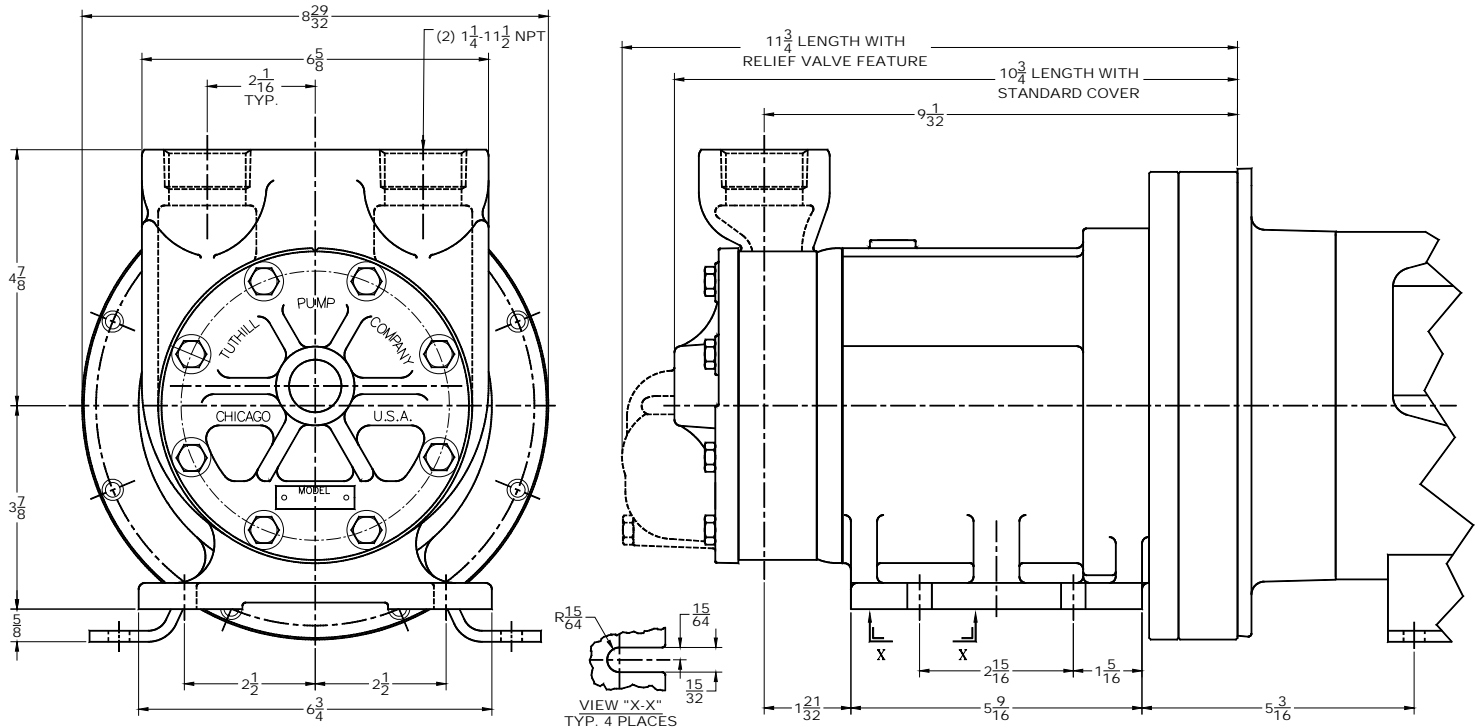

\*Note: Pump shown coupled to 182TC frame motor.

## MC4I Pump Mounting Dimensions

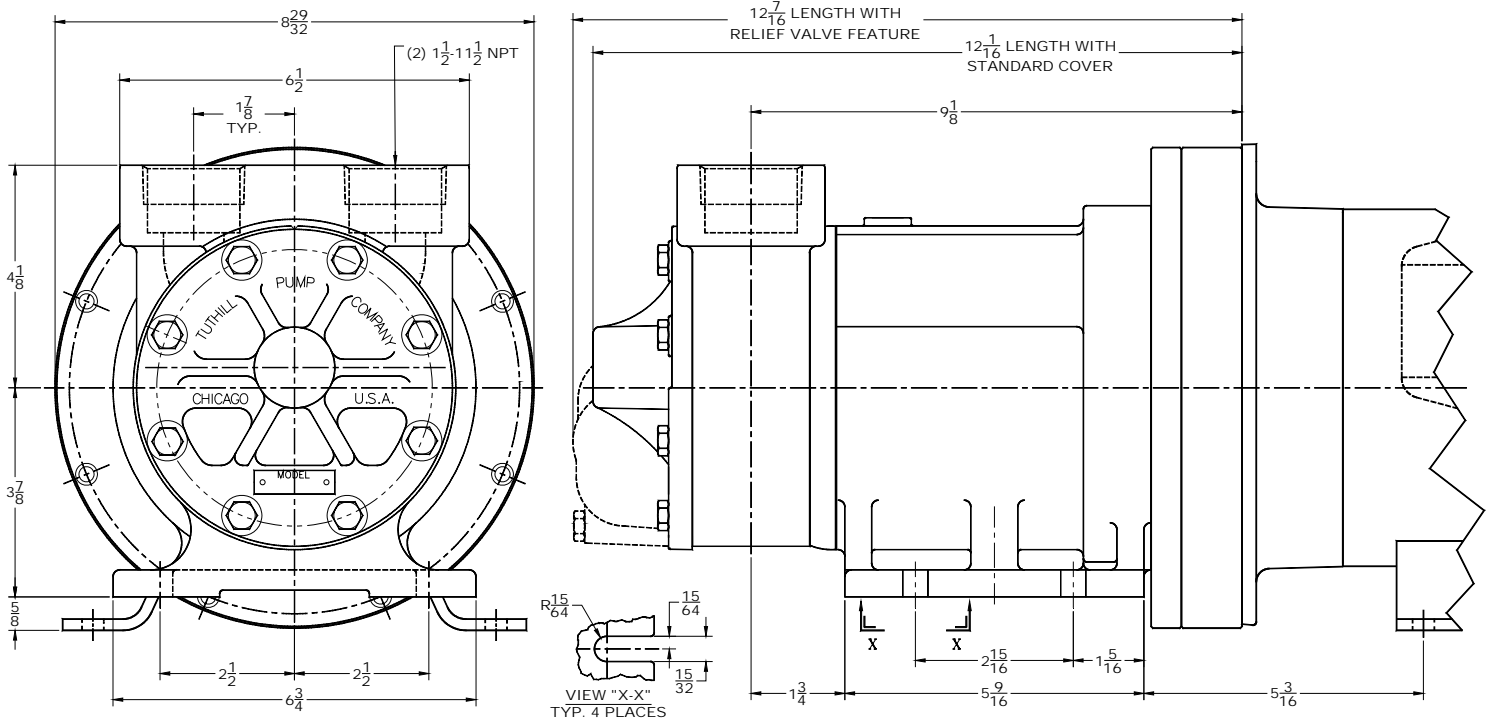

\*Note: Pump shown coupled to 182TC frame motor.

## MC5I Pump Mounting Dimensions

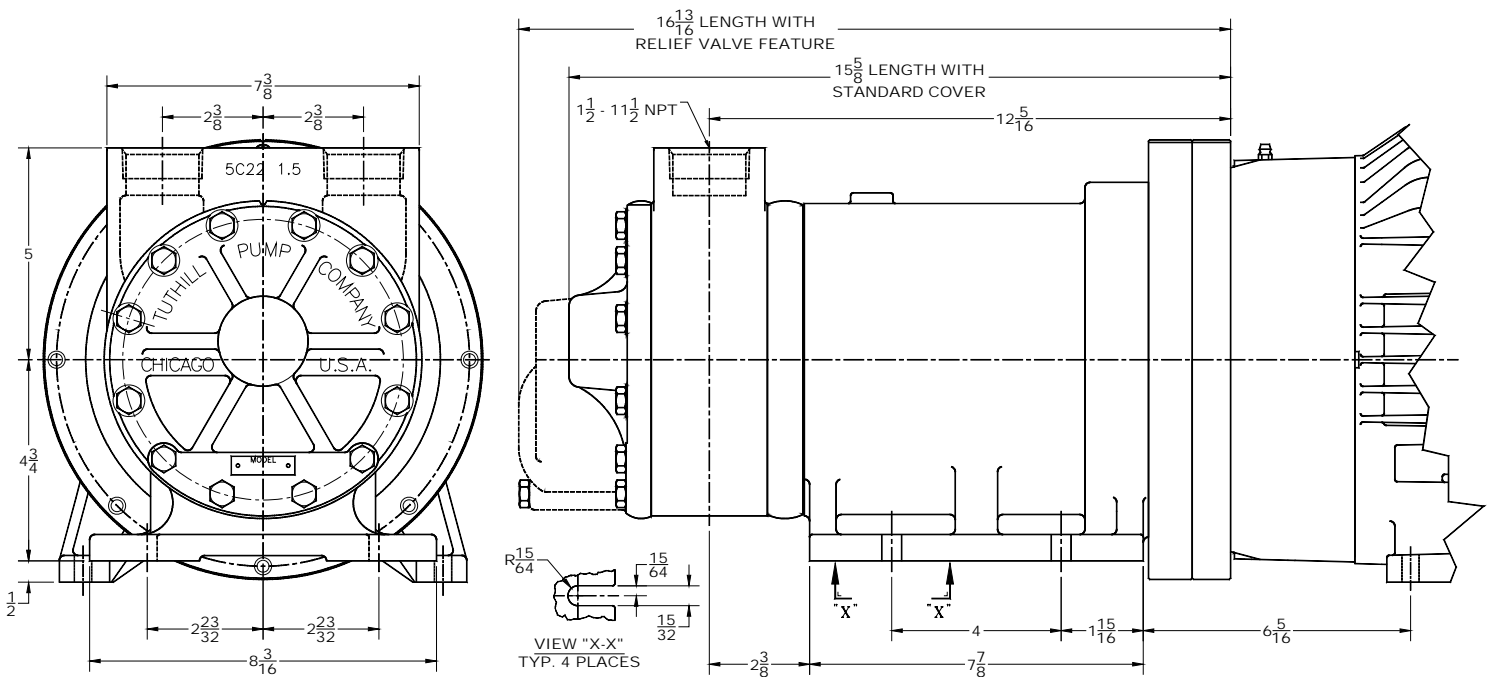

\*Note: Pump shown coupled to 213TC frame motor.



## MC6I Pump Mounting Dimensions

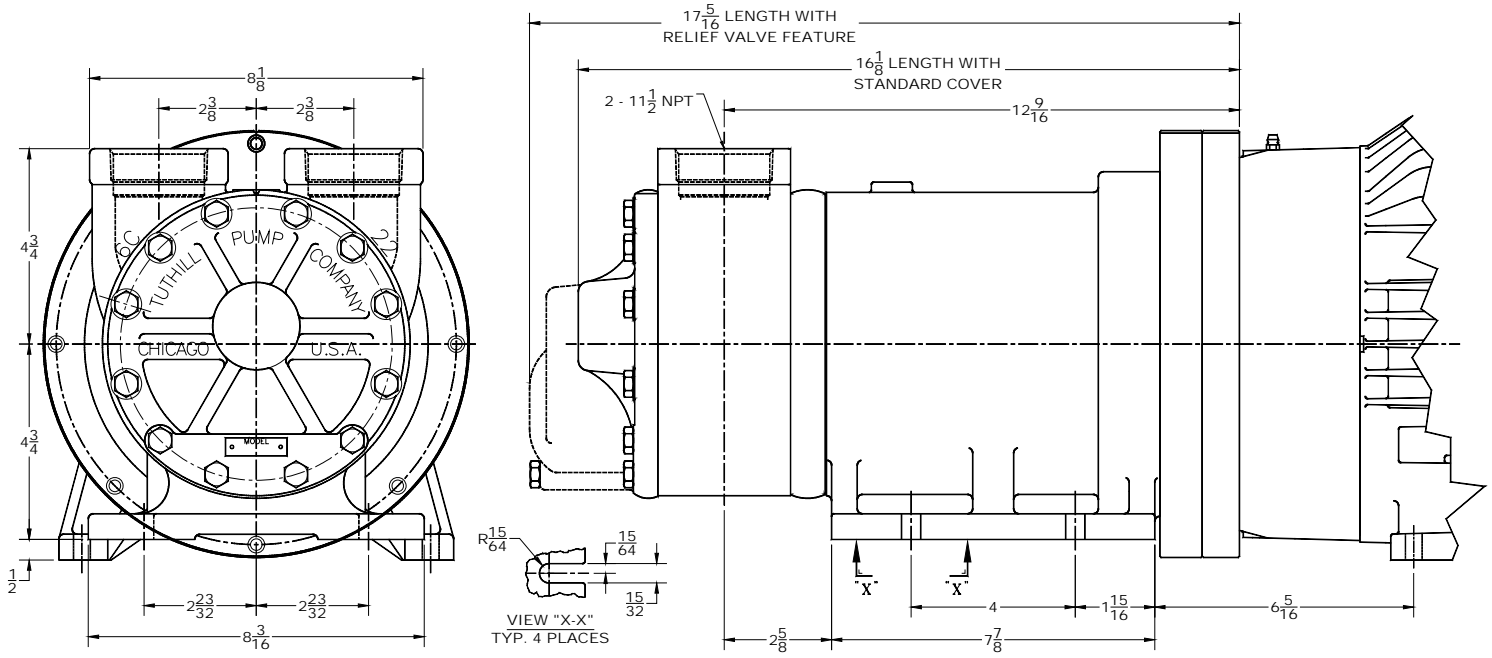

\*Note: Pump shown coupled to 213TC frame motor.



## ML Pump Performance Data

SIZE	RPM	40 SSU						200 SSU						500 SSU													
		0 PSI		50 PSI		100 PSI		0 PSI		50 PSI		100 PSI		0 PSI		50 PSI		100 PSI		200 PSI		300 PSI		500 PSI			
		GPM	HP	GPM	HP	GPM	HP	GPM	HP	GPM	HP	GPM	HP	GPM	HP	GPM	HP	GPM	HP	GPM	HP	GPM	HP	GPM	HP		
MLO1	300	-	-	-	-	-	-	-	-	-	-	-	-	-	-	-	-	-	-	-	-	-	-	-	-		
	900	0.8	1/8	0.7	1/8	0.6	1/8	0.8	1/8	0.8	1/8	0.8	1/8	0.7	1/4	0.5	1/3	0.3	1/2	0.7	1/8	0.7	1/8	0.6	1/4	0.5	1/2
	1200	1.0	1/8	0.9	1/8	0.8	1/4	1.0	1/8	1.0	1/8	0.9	1/4	0.9	1/4	0.8	1/2	0.6	3/4	1.0	1/8	1.0	1/4	0.9	1/4	0.7	1/2
	1800	1.6	1/4	1.4	1/4	1.3	1/4	1.6	1/4	1.6	1/4	1.5	1/4	1.4	3/4	1.4	3/4	1.2	1	1.6	1/8	1.5	1/4	1.4	1/2	1.3	3/4
	2400	-	-	-	-	-	-	2.2	1/2	2.2	1/2	2.1	1/2	2.0	1/2	2.0	3/4	-	-	2.0	1/4	2.0	1/2	1.9	1/2	-	-
	3600	-	-	-	-	-	-	3.2	1/2	3.1	1/2	3.1	1/2	2.9	1	-	-	-	-	2.9	1/3	2.8	1/2	2.8	3/4	2.8	1 1/2
ML11	300	0.4	1/8	0.3	1/8	-	-	0.4	1/8	0.4	1/8	0.2	1/8	0.1	1/8	-	-	-	-	0.4	1/8	0.4	1/8	0.3	1/8	0.3	1/4
	900	1.4	1/4	1.1	1/4	1.1	1/3	1.4	1/8	1.4	1/8	1.2	1/4	1.0	1/3	0.8	1/2	0.4	3/4	1.3	1/8	1.3	1/4	1.1	1/3	1.1	1/2
	1200	1.9	1/4	1.7	1/4	1.5	1/3	1.9	1/8	1.9	1/8	1.7	1/4	1.5	1/2	1.4	1/2	1.2	3/4	1.8	1/8	1.7	1/4	1.6	1/3	1.4	1/2
	1800	2.9	1/2	2.7	1/2	2.5	1/2	2.9	1/8	2.8	1/4	2.7	1/3	2.5	1/2	2.3	3/4	2.1	1 1/2	2.7	1/4	2.6	1/3	2.5	1/2	2.4	1
	2400	-	-	-	-	-	-	3.8	1/4	3.7	1/4	3.7	1/2	3.5	3/4	3.3	1	-	-	3.6	1/4	3.6	1/3	3.5	1/2	3.4	1
	3600	-	-	-	-	-	-	5.6	1/3	5.6	1/2	5.5	3/4	5.2	1	5.1	1 1/2	-	-	5.3	1/2	5.2	1/2	5.0	1 1/2	4.9	2
ML21	300	0.9	1/8	0.7	1/4	0.5	1/3	0.9	1/8	0.8	1/8	0.8	1/8	0.7	1/4	0.6	1/4	-	-	0.9	1/8	0.9	1/8	0.8	1/8	0.7	1/4
	900	2.8	1/4	2.5	1/2	2.2	3/4	2.8	1/8	2.7	1/4	2.7	1/4	2.6	1/2	2.4	3/4	2.2	1 1/2	2.7	1/8	2.6	1/8	2.3	1/4	2.1	1/2
	1200	3.7	1/2	3.4	1/2	3.1	3/4	3.7	1/8	3.4	1/4	3.1	1/2	2.8	1/2	3.0	1	2.8	1 1/2	3.6	1/8	3.5	1/4	3.3	1/2	2.7	3/4
	1800	5.4	1/2	4.9	3/4	4.8	1	5.5	1/4	4.9	1/2	4.9	1/2	4.6	3/4	4.3	1 1/2	3.8	2	5.3	1/4	5.2	1/3	4.9	1/2	4.0	1 1/2
	2400	-	-	-	-	-	-	7.1	1/4	6.9	1/2	6.6	3/4	6.3	1	6.3	1 1/2	-	-	6.9	1/2	6.8	1/2	6.6	3/4	6.0	1 1/2
	3600	-	-	-	-	-	-	-	-	-	-	-	-	-	-	-	-	-	-	-	-	-	-	-	-	-	-

SIZE	RPM	1000 SSU						5000 SSU																			
		0 PSI		50 PSI		100 PSI		0 PSI		50 PSI		100 PSI		500 PSI													
		GPM	HP	GPM	HP	GPM	HP	GPM	HP	GPM	HP	GPM	HP	GPM	HP												
MLO1	300	-	-	-	-	-	-	-	-	-	-	-	-	-	-	-	-	-	-	-	-	-	-	-	-	-	
	900	0.8	1/8	0.7	1/8	0.7	1/4	0.7	1/4	0.6	1/2	0.6	1/2	0.7	1/4	0.7	1/4	0.2	1/8	0.7	1/4	0.7	1/4	-	-	-	-
	1200	1.0	1/8	1.0	1/4	1.0	1/4	1.0	1/4	0.9	1/3	0.8	1/2	-	-	-	-	-	-	-	-	-	-	-	-	-	-
	1800	1.5	1/4	1.5	1/4	1.4	1/2	1.4	1/2	1.3	3/4	-	-	-	-	-	-	-	-	-	-	-	-	-	-	-	-
	2400	1.9	1/4	1.9	1/3	1.9	1/2	1.9	1/2	1.8	3/4	-	-	-	-	-	-	-	-	-	-	-	-	-	-	-	-
	3600	2.5	1/2	2.5	1/2	2.5	3/4	2.3	1	2.3	1	-	-	-	-	-	-	-	-	-	-	-	-	-	-	-	-
ML11	300	0.4	1/8	0.4	1/8	0.4	1/8	0.3	1/8	-	-	-	-	0.3	1/8	0.3	1/8	0.3	1/8	0.2	1/8	0.2	1/8	0.2	1/8	0.2	1/4
	900	1.4	1/8	1.4	1/8	1.3	1/8	1.2	1/4	1.1	1/3	0.9	3/4	1.1	1/4	1.1	1/4	1.1	1/4	0.9	1/3	0.9	1/3	0.7	1/2	-	-
	1200	1.9	1/8	1.9	1/8	1.8	1/4	1.7	1/3	1.6	1/2	1.4	3/4	-	-	-	-	-	-	-	-	-	-	-	-	-	
	1800	2.8	1/4	2.7	1/4	2.7	1/4	2.6	1/2	2.5	3/4	2.2	1 1/2	-	-	-	-	-	-	-	-	-	-	-	-	-	-
	2400	3.6	1/3	3.6	1/3	3.6	1/2	3.5	3/4	3.3	1	-	-	-	-	-	-	-	-	-	-	-	-	-	-	-	-
	3600	4.5	1/2	4.4	1/2	4.4	3/4	4.4	1 1/2	4.4	1 1/2	-	-	-	-	-	-	-	-	-	-	-	-	-	-	-	-
ML21	300	0.9	1/8	0.9	1/8	0.6	1/8	0.6	1/8	0.3	1/3	0.3	1/3	0.7	1/8	0.7	1/8	0.7	1/8	0.7	1/3	-	-	-	-	-	-
	900	2.7	1/8	2.6	1/4	2.5	1/4	2.2	1/2	1.6	3/4	0.7	1	1.9	1/4	1.8	1/3	0.7	1/2	-	-	-	-	-	-	-	-
	1200	3.5	1/4	3.4	1/4	3.3	1/3	3.0	3/4	2.6	3/4	1.8	1 1/2	-	-	-	-	-	-	-	-	-	-	-	-	-	-
	1800	5.0	1/3	4.9	1/2	4.9	3/4	4.7	1	4.2	1 1/2	3.4	2	-	-	-	-	-	-	-	-	-	-	-	-	-	-
	2400	5.4	1/2	5.3	3/4	5.2	1	5.0	1 1/2	4.9	1 1/2	-	-	-	-	-	-	-	-	-	-	-	-	-	-	-	-
	3600	-	-	-	-	-	-	-	-	-	-	-	-	-	-	-	-	-	-	-	-	-	-	-	-	-	-

## MC Pump Performance Data

SIZE	40 SSU						200 SSU						500 SSU						1000 SSU													
	0 PSI		50 PSI		100 PSI		0 PSI		50 PSI		100 PSI		150 PSI		0 PSI		50 PSI		100 PSI		150 PSI											
	GPM	HP	GPM	HP	GPM	HP	GPM	HP	GPM	HP	GPM	HP	GPM	HP	GPM	HP	GPM	HP	GPM	HP	GPM	HP										
MC2I	300	-	-	-	-	-	1.5	1/8	1.2	1/4	0.8	1/4	-	-	1.6	1/8	1.4	1/4	1.2	1/4	-	-	1.6	1/4	1.6	1/4	1.4	1/4	1.4	1/4	-	-
	900	3.8	1/4	2.4	1/2	3/4	4.5	1/4	4.0	1/2	3.3	3/4	2.2	1	4.6	1/4	4.0	1/3	3.3	3/4	3.0	1	4.8	1/2	4.6	1/2	3.8	3/4	3.5	1/2	3.5	1/2
	1200	5.0	1/3	3.6	1/2	1	6.0	1/3	5.4	1/2	4.5	1	3.7	1/2	6.2	1/3	5.3	1/2	4.5	1	4.2	1/2	6.6	1/2	6.4	3/4	6.0	1	5.2	2	5.2	2
	1800	7.6	1/2	6.0	3/4	1 1/2	9.0	1/2	8.0	3/4	7.0	1 1/2	6.7	2	9.2	1/2	8.4	1	7.5	1 1/2	7.0	2	9.8	3/4	9.5	1	9.0	1 1/2	8.5	3	8.5	3
MC3I	300	-	-	-	-	-	3.1	1/4	2.8	1/4	2.5	1/2	-	-	3.1	1/4	2.9	1/4	2.7	1/3	-	-	3.1	1/4	3.0	1/4	2.8	1/2	-	-	-	-
	900	7.5	1/2	6.0	1	4.8	1 1/2	9.0	1/2	8.5	1	8.0	1 1/2	5.0	1 1/2	9.2	3/4	8.5	1	8.2	1 1/2	9.4	1	9.4	1	8.5	1 1/2	6.5	2	6.5	2	
	1200	10.0	3/4	8.2	1	6.3	1 1/2	12.0	3/4	11.0	1	10.5	1 1/2	7.0	3	12.0	1	11.5	1 1/2	11.0	2	12.5	1 1/2	12.0	1 1/2	11.8	2	9.7	3	9.7	3	
	1800	15.0	1	12.2	1 1/2	9.5	3	18.0	1	17.0	1 1/2	16.0	3	13.0	5	18.1	1 1/2	18.0	2	16.3	3	18.7	2	18.5	2	17.0	3	15.5	5	15.5	5	
MC4I	300	-	-	-	-	-	6.0	1/8	5.5	1/3	5.0	1/2	-	-	6.0	1/4	5.8	1/3	5.5	1/2	-	-	6.2	1/4	5.9	1/3	5.6	3/4	-	-	-	-
	900	15.5	3/4	12.6	1 1/2	10.0	2	18.5	3/4	17.8	1 1/2	17.0	2	13.0	3	18.3	1	17.8	1 1/2	17.6	2	18.7	1 1/2	18.4	2	18.0	3	15.0	3	15.0	3	
	1200	20.9	3/4	17.4	1 1/2	14.0	3	24.5	3/4	23.8	1 1/2	23.0	3	18.0	3	24.5	1 1/2	24.0	2	23.7	3	24.9	2	24.5	3	24.0	5	21.0	5	21.0	5	
	1800	31.2	1 1/2	26.1	3	21.0	5	37.0	1 1/2	36.0	3	35.0	5	30.0	5	37.0	3	36.5	5	36.0	5	37.4	5	37.2	5	36.5	5	33.0	7 1/2	33.0	7 1/2	
MC5I	300	-	-	-	-	-	10.0	1/4	8.0	1/2	6.0	3/4	-	-	10.0	1/4	9.5	1/2	9.0	1	-	-	10.3	1/3	10.3	1/2	10.0	1	-	-	-	-
	900	25.0	1	21.0	2	16.0	3	31.0	1	29.0	2	27.0	3	20.0	5	30.8	1 1/2	30.0	3	29.2	5	30.8	2	30.8	3	30.1	5	26.0	5	26.0	5	
	1200	34.0	1 1/2	29.0	3	22.0	5	41.0	1 1/2	40.0	3	38.5	5	30.0	7 1/2	41.0	2	40.0	5	39.5	5	41.7	3	41.7	5	41.0	5	36.0	7 1/2	36.0	7 1/2	
	1800	53.0	3	45.0	5	36.0	7 1/2	61.7	3	61.0	5	60.0	7 1/2	50.0	10	61.7	5	61.0	5	60.0	7 1/2	61.7	5	61.7	7 1/2	61.0	7 1/2	56.0	10	56.0	10	
MC6I	300	-	-	-	-	-	14.0	1/2	12.0	3/4	10.0	1	-	-	14.0	3/4	13.5	3/4	13.0	1	-	-	14.2	3/4	14.0	1	13.0	1 1/2	-	-	-	-
	900	36.0	1 1/2	30.0	3	23.0	5	42.0	1 1/2	40.0	3	38.2	5	27.0	7 1/2	42.0	2	41.0	5	40.0	5	42.2	3	41.5	5	40.2	5	35.0	7 1/2	35.0	7 1/2	
	1200	47.5	2	40.0	5	32.0	7 1/2	56.0	2	54.0	5	52.5	7 1/2	42.0	7 1/2	56.0	3	55.0	5	54.0	7 1/2	56.0	5	55.0	5	54.0	7 1/2	47.0	10	47.0	10	
	1800	71.0	5	61.0	7 1/2	49.0	10	84.0	5	83.0	7 1/2	82.0	10	70.0	10	84.0	5	83.0	7 1/2	82.0	10	84.0	7 1/2	83.0	7 1/2	82.0	10	76.0	15	76.0	15	





## ML & MC Temperature Limits

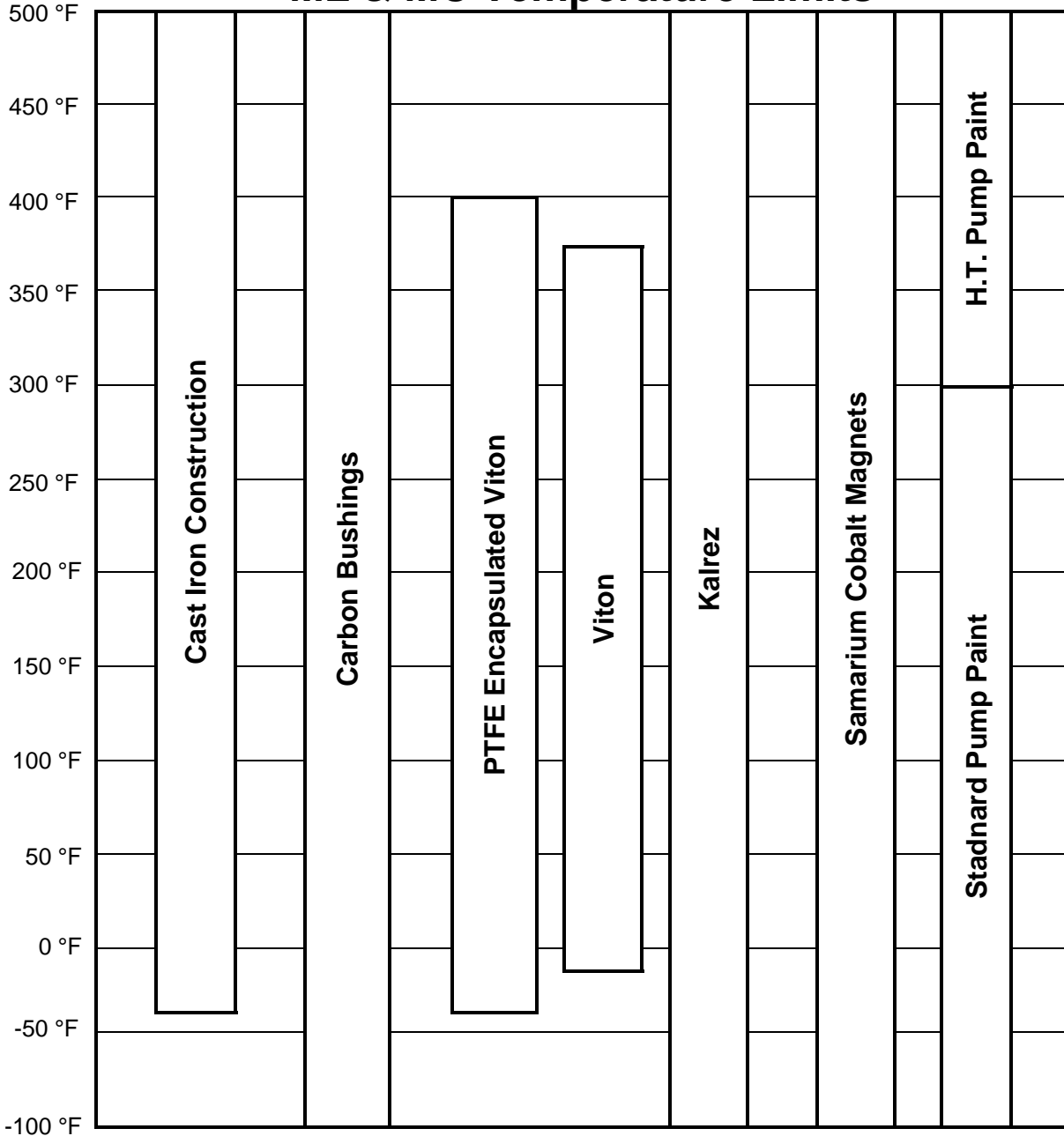

**Notes:**

1. A pump's performance is dependent on more than just the temperature ranges of the component materials.



## ML & MC Pump Materials of Construction

<i>Part Name</i>	<i>Material</i>	<i>Standard</i>	<i>Comments</i>	<i>Availability</i>
Housing	Cast Iron	ASTM A48		Std.
Housing Bushing	Steel	AISI 12L14		Std.
	Carbon	Carbon Graphite Resin		Std.
Cover	Cast Iron	ASTM A48 – 96a		Std.
Rotor	Steel	ASTM A311	Stressproof	Std.
Idler	Steel	AISI 1118 or AISI 1117		Std.
Idler Pin	Steel	AISI 1117	Case Hardened	Std.
Idler Bushing	Carbon	Carbon Graphite Resin		Std.
Housing Plug	Steel	AISI 12L14	DU Bushing is assembled in housing plug	Std.
O-Rings	Viton		Std. Mtl. used for cover seal	Std.
	PTFE Encapsulated Viton		Std. Mtl. used for canister seal	
Magnet Housing	Cast Iron	ASTM A48	Std. for MC Series	Std.
	Aluminum	ASTM SC64C	Std. for ML Series	Std.
Magnets	Samarium Cobalt			Std.
Canister	Stainless Steel	ASTM A276, grade 316		Std.



## ML Pump NPSH Data

### NPSH Required for Tuthill ML Series pumps 0-1000 SSU

PUMP SERIES \ SPEED RPM		300	600	900	1200	1500	1800
ML0I	FT.		1.0	1.8	2.2	2.5	2.9
ML1I	FT.		1.1	1.8	2.3	2.9	3.5
ML2I	FT.	1.1	2.3	3.0	3.8	5.8	7.0

**Notes:**

1. For liquid viscosity up to 1000 SSU.
2. NPSHA (Net Positive Suction Head Available) must be greater than the NPSHR (Net Positive Suction Head Required) value provided in the table.
3. Values above are for feet of liquid with a Specific Gravity of 1.0

### Viscosity Correction Factor

	Viscosity (SSU)		
	2500	5000	10000
Correction Factor	1.3	1.7	2.0



## MC Pump NPSH Data

### NPSH Required for Tuthill MC Series pumps 0-1000 SSU

SPEED RPM		PUMP SERIES					
		300	600	900	1200	1500	1800
MC2I	FT.	1.2	2.0	2.8	3.8	5.1	6.6
MC3I	FT.	1.4	2.4	3.6	5.2	7.1	9.4
MC4I	FT.	1.6	2.7	4.4	6.5	9.1	12.2
MC5I	FT.	1.8	3.0	5.2	8.2	11.9	16.2
MC6I	FT.	2.0	3.3	6.0	9.9	14.8	20.1

**Notes:**

1. For liquid viscosity up to 1000 SSU.
2. NPSHA (Net Positive Suction Head Available) must be greater than the NPSHR (Net Positive Suction Head Required) value provided in the table.
3. Values above are for feet of liquid with a Specific Gravity of 1.0.

### Viscosity Correction Factor

Correction Factor	Viscosity (SSU)			
	2500	5000	10000	25000
	1.3	1.7	2.0	2.7







## MG080I & MG080S Pump Mounting Dimensions

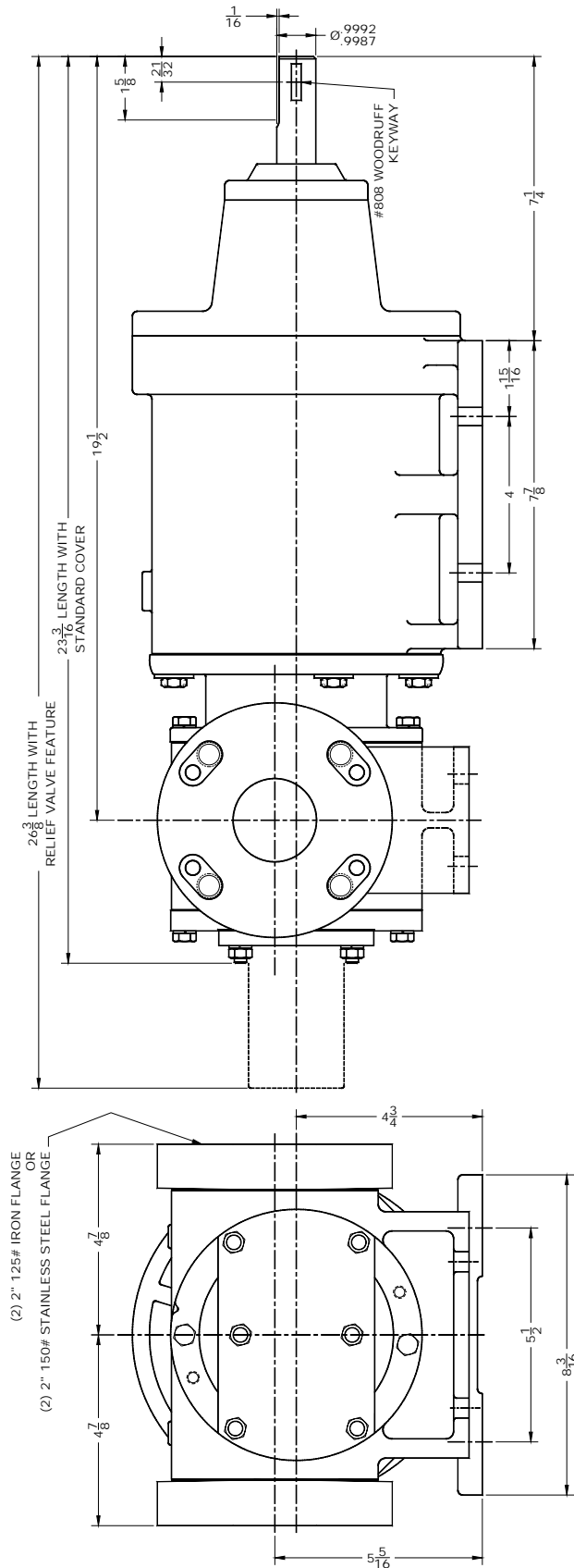



## MG Pump Performance Data

SIZE		25000 SSU											
		0 PSI		50 PSI		100 PSI		150 PSI		200 PSI			
RPM	GPM	HP	GPM	HP	GPM	HP	GPM	HP	GPM	HP	GPM	HP	
MG015I	250	2.3	1	-	-	-	-	-	-	-	-	-	
	500	4.5	1½	-	-	-	-	-	-	-	-	-	
	750	6.8	2	-	-	-	-	-	-	-	-	-	
MG030I	1000	9.1	3	-	-	-	-	-	-	-	-	-	
	250	-	-	-	-	-	-	-	-	-	-	-	
	500	-	-	-	-	-	-	-	-	-	-	-	
MG080I	750	-	-	-	-	-	-	-	-	-	-	-	
	1000	-	-	-	-	-	-	-	-	-	-	-	
	1500	7.2	1½	6.9	3	-	-	-	-	-	-	-	
MG080I	350	16.8	3	16.5	5	-	-	-	-	-	-	-	
	650	31.2	5	30.9	7½	-	-	-	-	-	-	-	
	850	40.8	7½	40.4	10	-	-	-	-	-	-	-	

\*\*Note: Stainless Steel versions @ 25000 SSU are rated at lower PSI.  
 MG015S & MG030S -> 150 PSID & 1000 RPM Max.  
 MG080S -> 150 PSID & 850 RPM Max.

SIZE		10000 SSU											
		0 PSI		50 PSI		100 PSI		150 PSI		200 PSI			
RPM	GPM	HP	GPM	HP	GPM	HP	GPM	HP	GPM	HP	GPM	HP	
MG015I	150	1.4	½	-	-	-	-	-	-	-	-	-	
	450	4.0	1	4.0	1½	-	-	-	-	-	-	-	
	850	7.7	2	7.6	3	-	-	-	-	-	-	-	
MG030I	1250	11.3	3	11.2	5	-	-	-	-	-	-	-	
	150	-	-	-	-	-	-	-	-	-	-	-	
	450	-	-	-	-	-	-	-	-	-	-	-	
MG080I	850	-	-	-	-	-	-	-	-	-	-	-	
	1250	-	-	-	-	-	-	-	-	-	-	-	
	250	12.0	2	11.6	3	11.5	5	-	-	-	-	-	
MG080I	500	24.0	3	23.6	5	23.3	7½	-	-	-	-	-	
	750	36.0	5	35.7	7½	35.4	10	-	-	-	-	-	
	1000	48.0	7½	47.7	10	47.3	15	-	-	-	-	-	

\*Note: Stainless Steel versions @ 10000 SSU are rated at lower PSI and RPM.  
 MG015S & MG030S -> 150 PSID & 1200 RPM Max.  
 MG080S -> 150 PSID & 1000 RPM Max.

SIZE		75000 SSU											
		0 PSI		50 PSI		100 PSI		150 PSI		200 PSI			
RPM	GPM	HP	GPM	HP	GPM	HP	GPM	HP	GPM	HP	GPM	HP	
MG015I	75	-	-	-	-	-	-	-	-	-	-	-	
	275	2.5	1	-	-	-	-	-	-	-	-	-	
	575	5.2	2	-	-	-	-	-	-	-	-	-	
MG030I	775	7.0	3	-	-	-	-	-	-	-	-	-	
	75	-	-	-	-	-	-	-	-	-	-	-	
	275	-	-	-	-	-	-	-	-	-	-	-	
MG080I	575	-	-	-	-	-	-	-	-	-	-	-	
	775	-	-	-	-	-	-	-	-	-	-	-	
	50	-	-	-	-	-	-	-	-	-	-	-	
MG080I	200	9.6	2	-	-	-	-	-	-	-	-	-	
	425	20.4	5	-	-	-	-	-	-	-	-	-	
	625	30.0	5	-	-	-	-	-	-	-	-	-	

\*\*\*Note: Stainless Steel versions @ 75000 SSU are rated at lower PSI.  
 MG015S & MG030S -> 150 PSID & 775 RPM Max.  
 MG080S -> 150 PSID & 625 RPM Max.

## MG Pump Temperature Limits

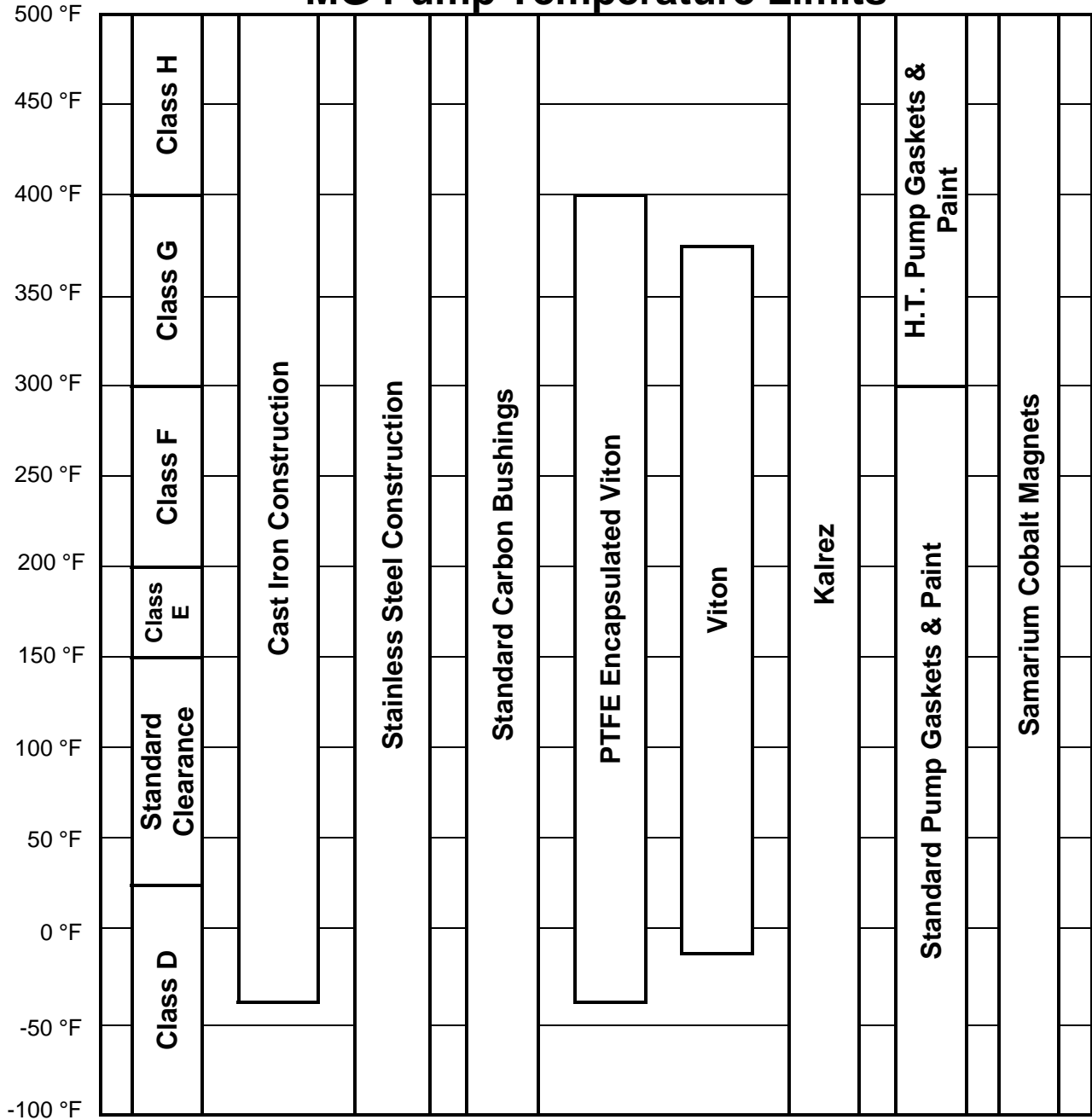

**Notes:**

1. A pump's performance is dependent on more than just the temperature ranges of the component materials.



## MGI & MGS Pump Materials of Construction

Part Name	Material	Standard	Comments	Availability	
				MGI	MGS
Housing & Cover	Cast Iron	ASTM A48		Std.	
	Stainless Steel	ASTM A743, grade CF8M	Cast Version of 316 S.S.		Std.
Bracket	Stainless Steel	ASTM A743, grade CF8M	Cast Version of 316 S.S.	Std.	Std.
Valve Block-Off Plate	Steel	AISI 1018		Std.	Std.
Rotor Head, Idler Gear	Ductile Iron	ASTM A536, grade 80-55-06		Std.	
	Stainless Steel	ASTM A494, grade CY5SnBiM	"Nitronic 60"		Std.
Rotor Shaft	Carbon Steel	AISI 4140		Std.	
	Hardened Steel	AISI 4140	Induction Hardened	Opt.	
	Stainless Steel	ASTM A564, grade 630	* "Armco 17-4PH"		Std.
	Hard-Coated S.S.	ASTM A564, grade 630	Chrome Oxide Coated		Opt.
Idler Pin	Hardened Steel	AISI 1117	Case Hardened	Std.	
	Stainless Steel	ASTM A276, grade 316		Opt.	Std.
	Hard-Coated S.S.	ASTM A276, grade 316	Chrome Oxide Coated	Opt.	Opt.
Bushings	Standard Carbon	Carbon Graphite Resin		Std.	Std.
	Tungsten Carbide	Grade C2		Opt.	Opt.
Gaskets	Standard	"Garlock" Style 3000		Std.	
	High Temp.	"Garlock" 3125 TCSS		Opt.	Std.
Magnet Housing	Cast Iron	ASTM A48	No contact with pumpage	Std.	Std.
Cover Jacket	Ductile Iron	ASTM A536, grade 80-55-06	No contact with pumpage	Opt.	Opt.
Magnets	Samarium Cobalt			Std.	Std.
Canister	Stainless Steel	ASTM A276, grade 316		Std.	Std.
O-Rings	PTFE Encapsulated Viton		Std. Mtl. used for canister seal	Std.	Std.

\* Std. = Standard, Opt. = Optional.



## MG Pump NPSH Data

### NPSH Required for Tuthill MG Series pumps 0-750 SSU

SPEED RPM  PUMP SERIES		150	250	350	450	550	750	950	1150	1450	1750
		<b>MG015</b>	<b>FT.</b>	<b>1.4</b>	<b>1.6</b>	<b>1.8</b>	<b>2.1</b>	<b>2.4</b>	<b>3.0</b>	<b>4.5</b>	<b>6.2</b>
<b>MG030</b>	<b>FT.</b>	<b>1.4</b>	<b>1.6</b>	<b>1.8</b>	<b>2.1</b>	<b>2.4</b>	<b>3.0</b>	<b>4.5</b>	<b>6.2</b>	<b>8.6</b>	<b>11.3</b>
<b>MG080</b>	<b>FT.</b>	<b>1.5</b>	<b>1.8</b>	<b>2.2</b>	<b>2.7</b>	<b>3.4</b>	<b>5.2</b>	<b>7.7</b>	<b>11.2</b>	<b>15.0</b>	<b>-</b>

**Notes:**

1. For liquid viscosity up to 750 SSU.
2. NPSHA (Net Positive Suction Head Available) must be greater than the NPSHR (Net Positive Suction Head Required) value provided in the table.
3. Values above are for feet of liquid with a Specific Gravity of 1.0.

### High Viscosity Correction Factors

Correction Factor	Viscosity (SSU)								
	2500	5000	10000	25000	50000	100000	250000	500000	1000000
	1.3	1.7	2.0	2.7	3.1	4.0	5.3	6.7	10.7



## MG Flange Ratings (Cast Iron)

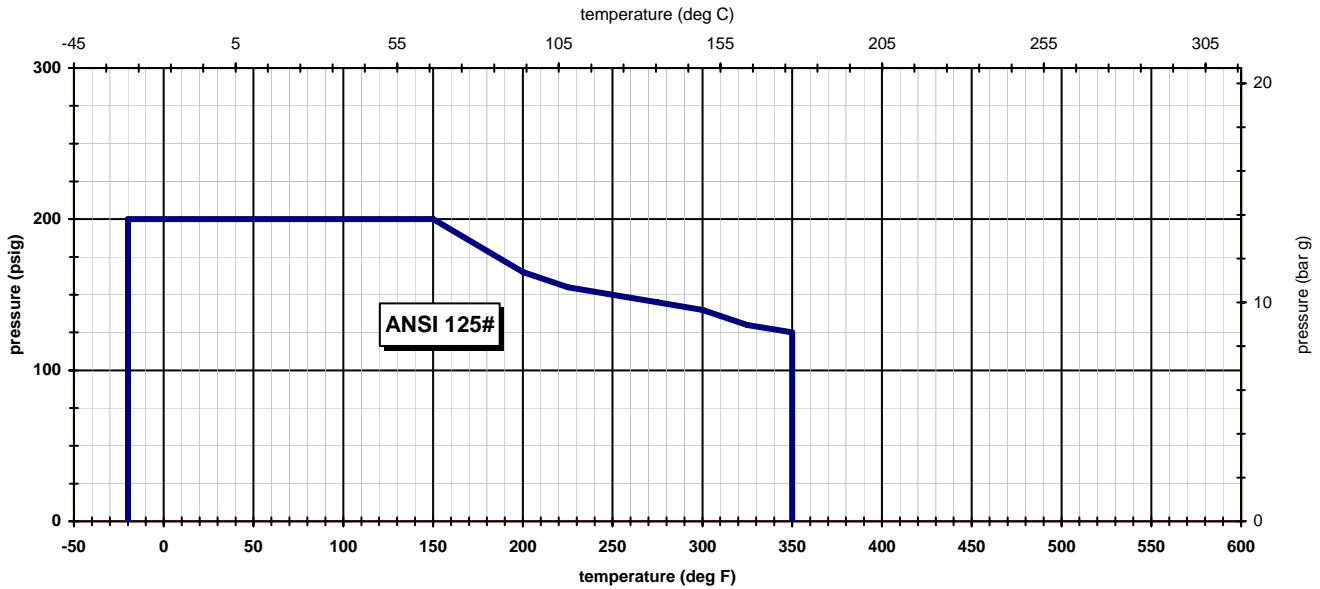

**NOTES:**

- 1) These charts show the ratings for flanges only - the maximum pump operating conditions must also be checked.
- 2) Consult the appropriate Tuthill catalog for maximum allowable operating pressures and temperatures, based on pump application conditions and pump features.
- 3) These ratings are based on non-shock pressures.
- 4) ANSI data is from ASME/ANSI B16.1 - 1989 (class A). Consult this spec for more information.

	<b>Warning</b>	<b>Rapid temperature change can result in flange failure and leakage, which can cause property damage or serious injury. Do not exceed cast iron tensile strength when bolting flanges.</b>
--	----------------	---



## MG Flange Ratings (Stainless Steel)

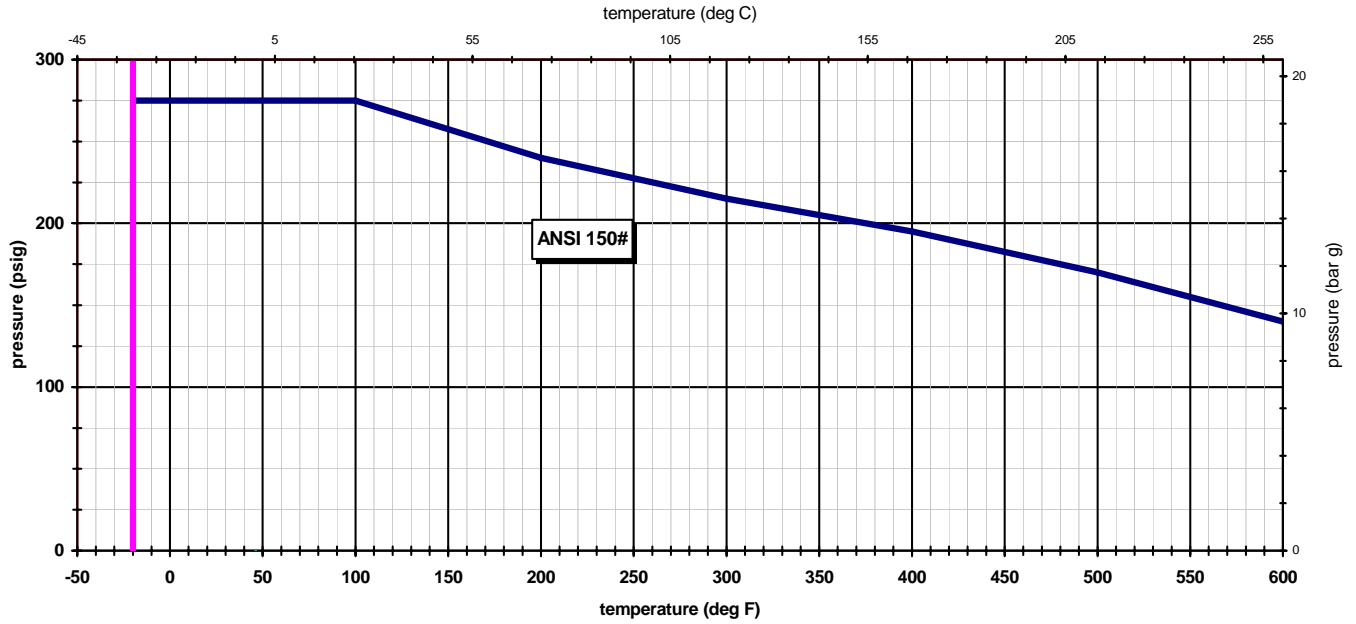

**NOTES:**

- 1) These charts show the ratings for flanges only - the maximum pump operating conditions must also be checked.
- 2) Consult the appropriate Tuthill catalog for maximum allowable operating pressures and temperatures, based on pump application conditions and pump features.
- 3) These ratings are based on non-shock pressures.
- 4) ANSI data is from ASME/ANSI B16.5 - 1988 (matl group 2.2). Consult this spec for more information.