



**TUTHILL
Pump Group**

12500 South Pulaski Road
Alsip, Illinois USA 60803
Tel 708 389-2500 Fax 708 388-0869
email: tuthillpump@tuthill.com
www.tuthill.com

Installation and Service Instructions

6000, 7000 & 8000 Series Magnetically Coupled Pumps

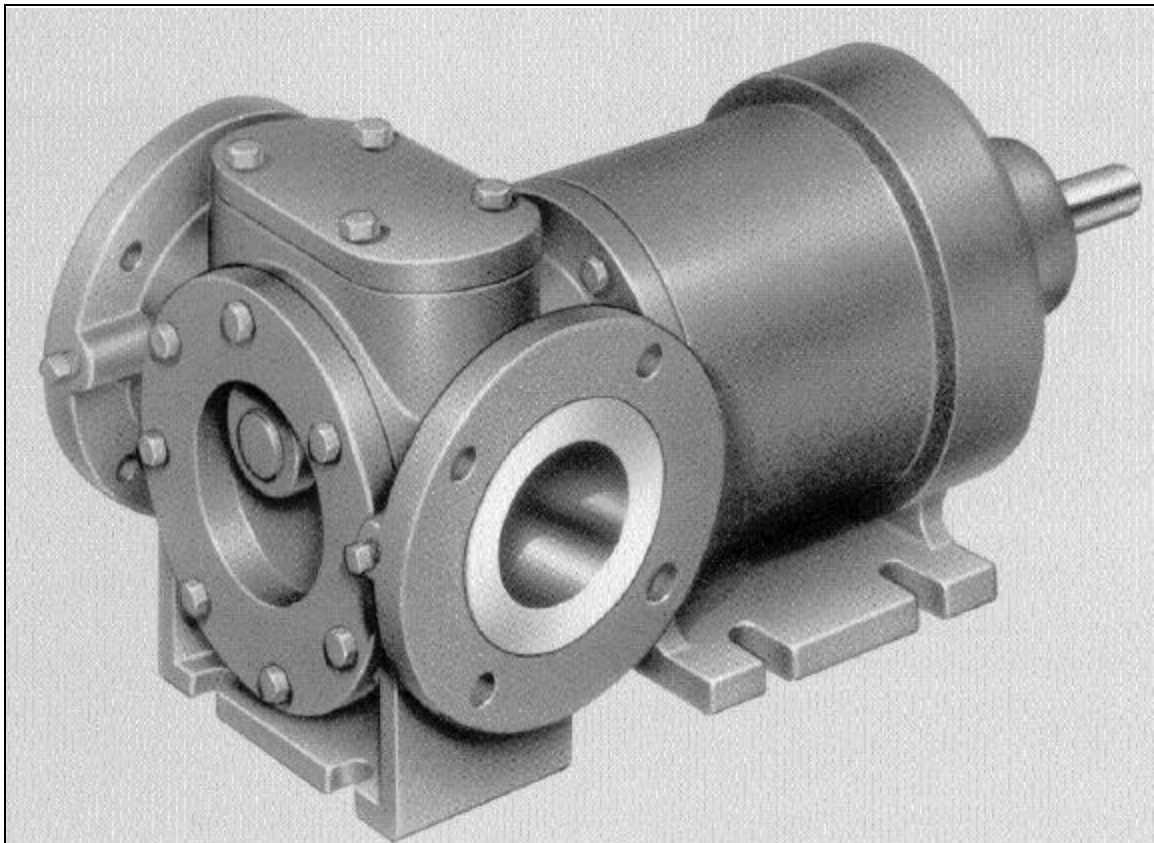

Table of Contents

Section	Description	Page
1	General Description	4
2	The Pumping Principle	5
3	Proper Installation	5
4	Pressure Limitations	6
5	Magnet Temperature Limitations	7
6	Optional Equipment	7
7	Method Of Drive	8
8	Location	8
9	Strainer Protection	8
10	Startup	9
11	Pump Disassembly Procedure - 6110 & 7110 Pumps	9
12	Pump Disassembly Procedure - 6200 Pumps	11
13	Pump Disassembly Procedure - 6210 Pumps	13
14	Pump Disassembly Procedure - 6300, 7200 & 8200 Pumps	15
15	Pump Disassembly Procedure - 6310, 7210 & 8210 Pumps	16
16	Pump Assembly Procedure - 6110 & 7110 Pumps	18
17	Pump Assembly Procedure - 6200 Pumps	20
18	Pump Assembly Procedure - 6210 Pumps	22
19	Pump Assembly Procedure - 6300, 7200 & 8200 Pumps	24
20	Pump Assembly Procedure - 6310, 7210 & 8210 Pumps	26
21	Troubleshooting	34
22	Material Returns	35



WARNING

The magnets in magnetically coupled pumps create very strong magnetic fields. Special care must be taken with the following:

Pacemakers - Magnets can upset the timing of pacemakers. These magnets should be kept away from all pacemakers. Because of the health risks involved the importance of this cannot be overstated.

Credit Cards - Magnets can scramble the information on a credit card's magnetic tape.

Computers, Computer Tapes and Computer Disks - Magnets can scramble the information on the memory device.

Watches - Magnets can affect the workings of traditional mechanical spring driven watches as well as chip and electronically controlled designs.

Electronic Instruments - Sensitive electronic instruments and devices may change calibration or be damaged by a powerful magnetic field.

Explosive Atmosphere - Rare earth magnets and magnetic materials may create sparks through contact in handling. Never handle rare earth magnets in explosive atmospheres because sparking may ignite the atmosphere.

Note: This manual replaces Service Manuals #66, 77 & 88.



WARNING

Magnetically coupled pumps (SEALLESS - as defined by the Hydraulic Institute) do not contain any dynamic seals. The possibility of leakage is therefore greatly reduced.

However, all materials are subject to wear and stress which can eventually lead to a failure, resulting in leakage. Without proper safeguards, leakage of hazardous fluids is potentially dangerous and can cause serious injury or death, or create an environmental hazard.

Users must understand and deal with this potential danger regardless which manufacturer's pump is used. If the fluid being pumped is hazardous, appropriate monitoring must be employed to provide early warning of any leakage. If you are unsure of the methods available to monitor your application, you should contact capable engineering firms for design guidance.

Magnetically coupled pumps may decouple and must be stopped to re-engage. Operation of a decoupled unit may destroy the magnets and will result in a serious danger of explosion when handling fluids with a low flash point because of very rapid heat buildup.

Magnetically coupled pumps are not designed to be run dry.



WARNING

Failure to follow these instructions could result in serious bodily injury or death.

Do not attempt to work on any Tuthill pump installation before completing the steps below.

Disconnect the drive so that it cannot be started while work is being performed.

Review the Material Safety Data Sheet (MSDS) applicable to the liquid being pumped to determine its characteristics and the precautions necessary to ensure safe handling.

Vent all pressure within the pump through the suction or discharge lines.

All Tuthill pumps contain residual hydraulic oil from the factory production test. Determine if this is compatible with the fluid you are pumping. If the fluid is incompatible, consult the factory.

Section 1: General Description

The Tuthill 6000, 7000 & 8000 Series pumps are magnetically-coupled versions of the Tuthill 4000 & ST Series pumps. These pumps operate on the internal gear pumping principle described below. These pumps do not contain any dynamic seals, thus eliminating any possibility of shaft seal leakage. The available models are shown in Table 1.

Materials of Construction	pump size	std port size		max capacity		max speed (rpm)	max pressure	
		(inch)	(mm)	(usgpm)	(lpm)		(psi)	(bar)
cast iron	6113	1/2	*	1.7	6	1800	500	34.5
	6114	1/2	*	3	11	1800	500	34.5
	6115	1	*	5.5	21	1800	500	34.5
	6202	1	*	9	34	1800	100	6.9
	6203	1 1/4	*	18	68	1800	100	6.9
	6204	1 1/2	*	37	140	1800	100	6.9
	6205	1 1/2	*	62	235	1800	100	6.9
	6206	2	*	84	318	1800	100	6.9
	6302	1	25	9	34	1800	200	13.8
	6303	1 1/2	40	15	57	1800	200	13.8
	6304	1 1/2	40	30	114	1800	200	13.8
	6305	2	50	50	189	1500	200	13.8
	6306	2 1/2	65	80	303	1500	200	13.8
	6307	3	80	135	511	1200	200	13.8
stainless steel	7114	1	*	2.8	11	1800	200	13.8
	7115	1	*	5.6	21	1800	200	13.8
	7202	1	25	6	23	1200	150	10.3
	7203	1 1/2	40	10	38	1200	150	10.3
	7204	1 1/2	40	20	76	1200	150	10.3
	7205	2	50	33	125	1000	150	10.3
	7206	2 1/2	65	53	201	1000	150	10.3
	7207	3	80	90	341	800	150	10.3
carbon steel	8202	1	25	9	34	1800	200	13.8
	8203	1 1/2	40	15	57	1800	200	13.8
	8204	1 1/2	40	30	114	1800	200	13.8
	8205	2	50	50	189	1500	200	13.8
	8206	2 1/2	65	80	303	1500	200	13.8
	8207	3	80	135	511	1200	200	13.8

* metric ports not available in these sizes

Table 1 - Models Available

Section 2: The Pumping Principle

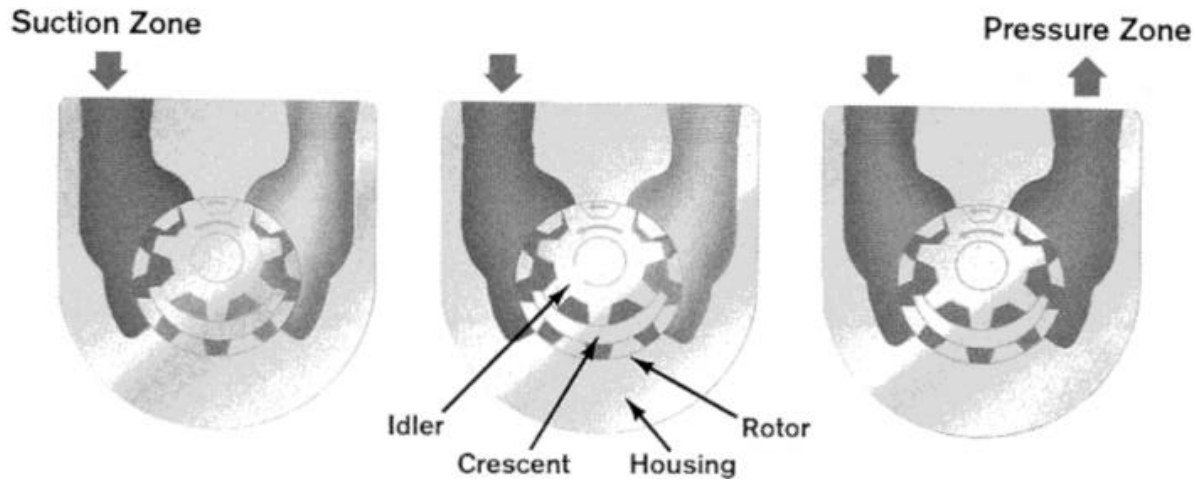

Figure 1 - Internal Gear Pumping Principle

Tuthill 6000, 7000 & 8000 Series pumps employ the internal gear pumping principle (see Figure 1). There are only two moving parts. Pumping action is based on a rotor, idler gear and crescent-shaped partition cast integral with the cover.

Power applied to the rotor is transmitted to the idler gear with which it meshes. The space between the outside diameter of the idler and the inside diameter of the rotor is sealed by the crescent.

As the pump starts, the teeth come out of mesh, increasing the volume. This creates a partial vacuum, drawing the liquid into the pump through the suction port.

The liquid fills the spaces between the teeth of the idler and the rotor and is carried past the crescent partition through the pressure side of the pump.

When the teeth mesh on the pressure side, the liquid is forced from the spaces and out through the discharge port.

Section 3: Proper Installation

Unsatisfactory pump installations are usually characterized by poor suction conditions for the specific liquid being handled. Suction conditions should be minimized to prevent vaporization of the liquid. If vacuum conditions force the liquid to vaporize, cavitation will occur, resulting in loss of capacity, premature wear and noisy operation.

For optimum pump performance, the suction line must be at least as large as the corresponding pump port. It should be as short as possible in order to avoid excessive pressure drops and must be airtight. The placement of a strainer on the suction side of the pump will restrict any solids or abrasives from entering the pump which could cause internal damage.

Note: Pipe line friction increases at a rapid rate with an increase in viscosity. For a given pump and motor, larger pipe lines are necessary to maintain the same pump pressure when changing from a thin fluid to a thick one.

When handling high viscosity liquids, the speed of the pump must be reduced and the size of the lines increased to prevent cavitation.

Under no conditions should the pump be used to support external piping loads. Piping and other equipment should be independently supported.

The discharge line must be designed with the maximum pressure rating of the pump in mind. Excessive pressure could cause damage to your motor and/or pump. If a pressure relief valve has not been supplied with the pump, some other means of pressure protection must be utilized. This could include in-line safety valves, pressure shutdown switches or other similar devices.

Every pump installation should have a good foundation. Its structure should be sufficiently strong to hold the pump rigid and to absorb any strain or shock that may be encountered. The installation should be leveled, checked for proper piping alignment, and then fastened securely.

Pumps should be filled with fluid at installation and should never be allowed to run dry.

6000, 7000 & 8000 Series pumps have internal venting which makes them directional. The direction of rotation is specified from the shaft end of the pump. Unless otherwise specified, rotation is assumed to be clockwise (CW), which places the suction port on the right side of the pump when viewed from the shaft end. Operation of the pump in a direction other than specified can cause damage to both the pump and magnets.

Consult Tuthill personnel whenever unusual conditions of speed, pressure, vacuum or viscosity are encountered.

The Tuthill pump is a positive displacement pump. As the pump rotates, liquid is positively delivered to the discharge side of the pump. If the discharge line is closed off, pressure will increase until the magnets de-couple, the drive equipment stalls and/or fails, the pump breaks or ruptures, or the piping bursts. This could result in serious bodily injury or death. To prevent this from happening, the use of a pressure relief valve is required. A relief valve that directs the flow back to the supply tank is recommended.

Pumps shipped from the factory with relief valves are assembled for clockwise or counterclockwise rotation as originally specified. The adjusting screw must always point toward the suction line. If you want to change rotation, the relief valve assembly must be removed and turned 180°, and the bracket must be rotated 180°.

Section 4: Pressure Limitations

Standard models have pressure ratings as shown in Table 1. Standard canisters are designed to withstand the maximum rated discharge pressure of the pump. The internal venting arrangement will normally result in a pressure in the canister that is less than the discharge pressure.



WARNING

Exceeding the maximum canister pressure may cause a canister failure resulting in the release of the fluid being pumped. Refer to the Optional Equipment section for options available for safely addressing this concern.

Consult the factory regarding any applications where the canister pressure is in question.

Section 5: Magnet Temperature Limitations

Standard pumps are supplied with magnets constructed of Neodymium-Iron-Boron. These magnets cannot exceed a maximum temperature of 250° F (120° C). Operation above the maximum temperature will result in a permanent reduction in magnet strength. Samarium-Cobalt magnets are available as an option and have a maximum temperature rating of 500° F (260° C). Generally, all magnets subjected to temperatures above their maximum rating will lose a portion or all of their magnetic strength.

To prevent damage to the magnets, use of a temperature sensor is recommended. Refer to Section 6: Optional Equipment for further details.

Section 6: Optional Equipment

Sensing equipment must be installed to immediately shut down the system when any abnormality is detected.

Secondary Control

This feature converts the outer pump adapter into a secondary control chamber. In the event of fluid leakage from the primary chamber, this option provides a temporary backup system for preventing leakage into the environment, with proper sensing devices. Use of secondary control is recommended when handling hazardous or toxic fluids. Secondary control cannot be expected to contain pressure or significant fluid loss.

Provided with this option are two tapped ports in the outer pump adapter, which will accommodate various sensors:

- **Leak Sensor** - Installed into the lower tapped port, it monitors for fluid within the secondary containment chamber to indicate inner canister failure.
- **Temperature Sensor** - Installed into the upper tapped port, it monitors canister temperature to help prevent magnet damage due to excessive heat.
- **Cooling Jacket** - Utilizes both tapped ports and the secondary control chamber to disperse heat from the canister and magnets.

Pumps must be inspected weekly to verify the integrity of the secondary control feature. More frequent inspection may be necessary, dependent on the specific application.

Bracket Access

This option incorporates two access holes in the pump bracket to provide a direct passage to the inner magnet for use as follows:

- **Pressure Sensor** - monitors pressure in the inner canister.
- **Flush** - allows for flushing of canister chamber.
- **Drain** - allows for draining of canister chamber.

Section 7: Method Of Drive

Direct drive through a traditional flexible coupling is recommended. However, do not expect the flexible coupling to compensate for misalignment. Contact the coupling manufacturer to determine the maximum amount of misalignment which the coupling can tolerate.

All pump and motor units must be properly aligned during assembly and periodically checked since misalignment may occur later due to changing conditions.

Pipe strain can force the pump and motor shaft out of alignment. Therefore, all piping to the pump must be properly supported. Do not allow the pump to act as a pipe support.

Provide for proper expansion of pipes when handling hot liquids. Allow pump to reach operating temperatures and then re-check alignment.

Provide sufficient clearance, 1/16 - 1/18 inches (1.5 - 3 mm) between coupling halves with shaft in closest operating position.

Never depend upon sight or feel. Use proper gauges when aligning a pump.

Never operate pump without all guards in place.

Section 8: Location

The pump should be located as close to the source of supply as conditions permit and if possible, below the level of the liquid in the reservoir. When necessary to locate the pump in a pit, provisions should be made to safeguard against flooding. Care must be taken to properly support the suction and discharge piping so that no strain is put on the pump due to either weight or expansion. Piping strain can result in misalignment, hot bearings, worn couplings, and vibration. It is important that the piping used be clean and free of chips or scales.

Section 9: Strainer Protection

Strainers are used to remove contaminated particles from the fluid system and extend pump life. Every pump should be protected from these particles by a strainer in the suction line.

Strainer size and mesh of screen is determined by rate of flow and viscosity of fluid. Consult strainer manufacturer for recommendations.

Never use a strainer with built-in automatic by-pass on the suction line set to open under 30 inch (750 mm) Hg. vacuum.

Install strainer according to the designated direction of flow.

Have strainer accessible for servicing.

Use a duplex type strainer when shutdown during service is not permitted.

Provide a vacuum gauge in the suction line for determining when the strainer requires cleaning.

Make certain strainer baskets are properly reinforced so as not to collapse under 30 inch (750 mm) Hg. vacuum.

Section 10: Startup



WARNING

Follow all precautions outlined in the Material Safety Data Sheet (MSDS) applicable to the liquid being pumped to ensure safe handling.

All Tuthill pumps contain residual hydraulic oil from the factory production test. Determine if this is compatible with the fluid you are pumping. If the fluid is incompatible, consult the factory.

Prior to starting the pump double check the following:

- Pressure and vacuum gauges should be installed as close as possible to the pump.
- Rotate pump shaft to ensure it turns freely without binding.
- Recheck alignment and ensure all guards are in place.
- Make sure piping is independently supported and no strain is being transmitted to the pump.
- Make sure the safety relief valve is installed correctly.
- Open suction and discharge gate valves.
- Check for any leaks once gate valves are open.
- Check pump rotation.

After completing these checks the pump can be started.



CAUTION

The pump should not be run dry. If after approximately 60 seconds there is no discharge of liquid, stop the pump and investigate the possible cause. Failure to comply with this could cause severe damage to magnets, bushings and/or metal parts.

Section 11: Pump Disassembly Procedure - 6110 & 7110 Pumps

Refer to Figure 3 (6110) & Figure 4 (7110).

Although some minor disassembly is possible with the complete pump/motor assembly still in place, it is recommended that the pump/motor unit be disconnected and moved to a maintenance area.



WARNING

Residual pumped fluid will be present in the pump. Follow all precautions outlined in the Material Safety Data Sheet (MSDS) applicable to the liquid being pumped to ensure safe handling.

1. Remove piping from the ports.
2. Mark cover and housing before disassembly to ensure proper reassembly.
3. Remove the cover screws, cover and idler.
4. Inspect the following parts carefully for deep grooves, scratches or other damage:
 - The end face of the rotor
 - The O.D. of the idler
 - The I.D. of the idler.
 - Both faces of the idler.
 - The O.D. of the idler pin.
 - The inside surfaces of the cover including the crescent.
5. Check for signs of wear. A decrease in capacity is generally caused by the abrasive action of foreign materials in the liquid, resulting in excessive end clearances. End clearance can be reduced by changing to a thinner cover gasket. To adjust the end clearance, see assembly procedure.



CAUTION

The pump must be separated from the magnet coupling if further disassembly is required. Follow the instructions below.

The housing, rotor and inner magnet can be removed by hand.

DO NOT PLACE HAND OR FINGERS BETWEEN THE HOUSING AND ADAPTER. The magnets are extremely strong and will attract all metallic objects and can be the source of pinch points. Do not wear watches or other metallic jewelry when working with magnets. See warning on Page 2.

Failure to follow proper procedures or use appropriate tools could result in injury to you or damage to either personal property or the pump.

6. Remove the housing screws.
7. Remove the pump head assembly from the adapter, making sure to pull it straight off.
8. Remove the canister from the housing. The canister will probably contain pumping residue. Use care when removing, making sure to pull the canister straight off. Inspect the canister I.D. and O.D. for evidence of contact or wear.
9. Set the housing, rotor and inner magnet assembly face-down. Remove the retaining ring, inner magnet and key.
10. Set the magnet down on a clean, non-magnetic surface. Inspect the magnet sleeve for evidence of damage or excessive wear and cover with a cloth to prevent contamination.
11. Check the shaft O.D. for any burrs and remove to prevent damage to the housing bushing.

12. Inspect the following parts carefully for deep grooves, scratches or other damage:
 - The I.D. surface of the housing.
 - The back face of the rotor.
 - The back face of the housing bushing.
 - The O.D. of the rotor.
13. Inspect the bushings in the housing for wear.
14. Do not remove the o-ring from the housing unless it is worn or damaged and needs replacement.

Section 12: Pump Disassembly Procedure - 6200 Pumps

Refer to Figure 5.

Although some minor disassembly is possible with the complete pump/motor assembly still in place, it is recommended that the pump/motor unit be disconnected and moved to a maintenance area.



WARNING

Residual pumped fluid will be present in the pump. Follow all precautions outlined in the Material Safety Data Sheet (MSDS) applicable to the liquid being pumped to ensure safe handling.

1. Remove piping from the ports.
2. Mark cover, housing and bracket before disassembly to ensure proper reassembly.
3. Remove the cover screws, cover, housing and idler.
4. Inspect the following parts carefully for deep grooves, scratches or other damage:
 - The I.D. of the housing.
 - The end face of the rotor.
 - The O.D. of the rotor.
 - The O.D. of the idler.
 - The I.D. of the idler.
 - Both faces of the idler.
 - The O.D. of the idler pin.
 - The inside surfaces of the cover including the crescent.
5. Check for signs of wear. A decrease in capacity is generally caused by the abrasive action of foreign materials in the liquid, resulting in excessive end clearances. End clearance can be reduced by changing to a thinner cover gasket. To adjust the end clearance, see assembly procedure.



CAUTION

The pump must be separated from the magnet coupling if further disassembly is required. Follow the instructions below.

Use jack screws to disassemble models 6200 Series pumps. Jack screw kits are available as part number 2CMG 558 for models 6202, 6203 and 6204 and part number 5CMG 558 for models 6205 and 6206.

DO NOT PLACE HAND OR FINGERS BETWEEN THE HOUSING AND ADAPTER. The magnets are extremely strong and will attract all metallic objects and can be the source of pinch points. Do not wear watches or other metallic jewelry when working with magnets. See warning on Page 2.

Failure to follow proper procedures or use appropriate tools could result in injury to you or damage to either personal property or the pump.

6. Remove the screws that attach the bearing housing / outer magnet sub-assembly to the adapter.
7. Use jack screws to separate the inner and outer magnets:
 - a. Place (3) guide studs into adapter at screw locations and hand tighten.
 - b. Place (1) threaded stud into bearing housing and slowly turn the threaded stud to jack the bearing housing / outer magnet sub-assembly out.
 - c. Continue turning the threaded stud until separation of the inner and outer magnet is complete.
8. Remove pump bracket, rotor and canister sub-assembly from adapter.
9. Remove the canister from the bracket. The canister will probably contain residual pumping fluid. Use care when removing, making sure to pull the canister straight off.
10. Remove the back retaining ring and remove the inner magnet.
11. Set magnet down on a clean, non-magnetic surface, inspect the magnet sleeve for evidence of damage or excessive wear and cover with a cloth to prevent contamination.
12. Remove the front retaining ring (if equipped). Check the shaft O.D. for any burrs and remove to prevent damage to the bracket bushings.
13. Remove the rotor from the bracket.
14. The back face of the rotor and the bracket face should be inspected for any deep scratches or wear. Inspect the bushing in the bracket for wear.
15. Do not remove the o-ring from the bracket unless it is worn or damaged and needs replacement.

Section 13: Pump Disassembly Procedure - 6210 Pumps

Refer to Figure 6.

Although some minor disassembly is possible with the complete pump/motor assembly still in place, it is recommended that the pump/motor unit be disconnected and moved to a maintenance area.



WARNING

Residual pumped fluid will be present in the pump. Follow all precautions outlined in the Material Safety Data Sheet (MSDS) applicable to the liquid being pumped to ensure safe handling.

1. Remove piping from the ports.
f
2. Remove the cover screws, cover, housing and idler.
3. Mark cover, housing and bracket before disassembly to ensure proper reassembly.
4. Inspect the following parts carefully for deep grooves, scratches or other damage:
 - The I.D. of the housing.
 - The end face of the rotor.
 - The O.D. of the rotor.
 - The O.D. of the idler.
 - The I.D. of the idler.
 - Both faces of the idler.
 - The O.D. of the idler pin.
 - The inside surfaces of the cover including the crescent.
5. Check for signs of wear. A decrease in capacity is generally caused by the abrasive action of foreign materials in the liquid, resulting in excessive end clearances. End clearance can be reduced by changing to a thinner cover gasket. To adjust the end clearance, see assembly procedure.



CAUTION

The pump must be separated from the magnet coupling if further disassembly is required. Follow the instructions below.

Use jack screws to disassemble models 6210 Series pumps. Jack screw kits are available as part number 2CMG 558 for models 6212, 6213 and 6214 and part number 5CMG 558 for models 6215 and 6216.

DO NOT PLACE HAND OR FINGERS BETWEEN THE BRACKET AND ADAPTER. The magnets are extremely strong and will attract all metallic objects and can be the source of pinch points. Do not wear watches or other metallic jewelry when working with magnets. See warning on Page 2.

Failure to follow proper procedures or use appropriate tools could result in injury to you or damage to either personal property or the pump.

6. Remove the screws that attach the bearing housing / outer magnet sub-assembly to the adapter.
7. Use jack screws to separate the inner and outer magnets:
 - a. Place (3) guide studs into adapter through the bracket screw clearance holes and hand-tighten.
 - b. Place (1) threaded stud into a bracket screw threaded hole and slowly turn the threaded stud to jack the bracket / rotor / inner magnet sub-assembly out.
 - c. Continue turning the threaded stud until separation of the inner and outer magnet is complete.
8. Remove bracket / rotor / inner magnet sub-assembly from adapter.
9. Remove the canister from the bracket. The canister will probably contain residual pumping fluid. Use care when removing, making sure to pull the canister straight off. Inspect the canister I.D. and O.D. for evidence of contact or wear.
10. Set the bracket / rotor / inner magnet assembly face-down. Remove the retaining ring, inner magnet and key.
11. Set the magnet down on a clean, non-magnetic surface. Inspect the magnet sleeve for evidence of damage or excessive wear and cover with a cloth to prevent contamination.
12. Remove the front retaining ring (if equipped). Check the shaft O.D. for any burrs and remove to prevent damage to the bracket bushings.
13. Remove the rotor from the bracket.
14. The back face of the rotor and the bracket face should be inspected for any deep scratches or wear. Inspect the bushings in the bracket for wear.
15. Do not remove the o-ring from the housing unless it is worn or damaged and needs replacement.

Section 14: Pump Disassembly Procedure - 6300, 7200 & 8200 Pumps

Refer to Figure 7.

Although some minor disassembly is possible with the complete pump/motor assembly still in place, it is recommended that the pump/motor unit be disconnected and moved to a maintenance area.



WARNING

Residual pumped fluid will be present in the pump. Follow all precautions outlined in the Material Safety Data Sheet (MSDS) applicable to the liquid being pumped to ensure safe handling.

1. Remove piping from the ports.
2. Mark cover, housing and bracket before disassembly to ensure proper reassembly.
3. Remove the cover screws, cover, housing and idler.
4. Inspect the following parts carefully for deep grooves, scratches or other damage:
 - The I.D. of the housing.
 - The end face of the rotor.
 - The O.D. of the rotor.
 - The O.D. of the idler.
 - The I.D. of the idler.
 - Both faces of the idler.
 - The O.D. of the idler pin.
 - The inside surfaces of the cover including the crescent.
5. Check for signs of wear. A decrease in capacity is generally caused by the abrasive action of foreign materials in the liquid, resulting in excessive end clearances. End clearance can be reduced by adjusting the thrust bearing. To adjust the end clearance, see assembly procedure.



CAUTION

The pump must be separated from the magnet coupling if further disassembly is required. Follow the instructions below.

Use jack screws to disassemble models 6300, 7200 & 8200 Series pumps. Jack screw kits are available as part number 2CMG 558 for models 6302-4, 7202-4 & 8202-4 and part number 5CMG 558 for models 6305-6, 7205-6 & 8205-6.

DO NOT PLACE HAND OR FINGERS BETWEEN THE HOUSING AND ADAPTER. The magnets are extremely strong and will attract all metallic objects and can be the source of pinch points. Do not wear watches or other metallic jewelry when working with magnets. See warning on Page 2.

Failure to follow proper procedures or use appropriate tools could result in injury to you or damage to either personal property or the pump.

6. Remove the screws that attach the bearing housing / outer magnet sub-assembly to the adapter.

7. Use jack screws to separate the inner and outer magnets:
 - a. Place (3) guide studs into adapter at screw locations and hand-tighten.
 - b. Place (1) threaded stud into bearing housing and slowly turn the threaded stud to jack the bearing housing / outer magnet sub-assembly out.
 - c. Continue turning the threaded stud until separation of the inner and outer magnet is complete.
8. Remove pump bracket, rotor and canister sub-assembly from adapter.
9. Remove the canister from the bracket. The canister will probably contain residual pumping fluid. Use care when removing, making sure to pull the canister straight off.
10. Remove the back retaining ring and remove the inner magnet.
11. Set magnet down on a clean, non-magnetic surface, inspect the magnet sleeve for evidence of damage or excessive wear and cover with a cloth to prevent contamination.
12. Remove the front retaining ring (if equipped).
13. Loosen the setscrews and remove the adjusting ring. Check for excessive wear. Check the shaft O.D. for any burrs and remove to prevent damage to the bracket bushings.
14. Remove the rotor from the bracket.
15. The back face of the rotor and the bracket face should be inspected for any deep scratches or wear. Inspect the bushing in the bracket for wear.
16. Do not remove the o-ring from the bracket unless it is worn or damaged and needs replacement.

Section 15: Pump Disassembly Procedure - 6310, 7210 & 8210 Pumps

Refer to Figure 8.

Although some minor disassembly is possible with the complete pump/motor assembly still in place, it is recommended that the pump/motor unit be disconnected and moved to a maintenance area.



WARNING

Residual pumped fluid will be present in the pump. Follow all precautions outlined in the Material Safety Data Sheet (MSDS) applicable to the liquid being pumped to ensure safe handling.

1. Remove piping from the ports.
2. Remove the cover screws, cover, housing and idler.

3. Mark cover, housing and bracket before disassembly to ensure proper reassembly.
4. Inspect the following parts carefully for deep grooves, scratches or other damage:
 - The I.D. of the housing.
 - The end face of the rotor.
 - The O.D. of the rotor.
 - The O.D. of the idler.
 - The I.D. of the idler.
 - Both faces of the idler.
 - The O.D. of the idler pin.
 - The inside surfaces of the cover including the crescent.
5. Check for signs of wear. A decrease in capacity is generally caused by the abrasive action of foreign materials in the liquid, resulting in excessive end clearances. End clearance can be reduced by changing to a thinner cover gasket. To adjust the end clearance, see assembly procedure.



CAUTION

The pump must be separated from the magnet coupling if further disassembly is required. Follow the instructions below.

Use jack screws to disassemble models 6310, 7210 & 8210 Series pumps. Jack screw kits are available as part number 2CMG 558 for models 6312-4, 7212-4 & 8212-4 and part number 5CMG 558 for models 6315-6, 7215-6 & 8215-6.

DO NOT PLACE HAND OR FINGERS BETWEEN THE BRACKET AND ADAPTER. The magnets are extremely strong and will attract all metallic objects and can be the source of pinch points. Do not wear watches or other metallic jewelry when working with magnets. See warning on Page 2.

Failure to follow proper procedures or use appropriate tools could result in injury to you or damage to either personal property or the pump.

6. Remove the screws that attach the bearing housing / outer magnet sub-assembly to the adapter.
7. Use jack screws to separate the inner and outer magnets:
 - a. Place (3) guide studs into adapter through the bracket screw clearance holes and hand-tighten.
 - b. Place (1) threaded stud into a bracket screw threaded hole and slowly turn the threaded stud to jack the bracket / rotor / inner magnet sub-assembly out.
 - c. Continue turning the threaded stud until separation of the inner and outer magnet is complete.

8. Remove bracket / rotor / inner magnet sub-assembly from adapter.
9. Remove the canister from the bracket. The canister will probably contain residual pumping fluid. Use care when removing, making sure to pull the canister straight off. Inspect the canister I.D. and O.D. for evidence of contact or wear.
10. Set the bracket / rotor / inner magnet assembly face-down. Remove the retaining ring, inner magnet and key.
11. Set the magnet down on a clean, non-magnetic surface. Inspect the magnet sleeve for evidence of damage or excessive wear and cover with a cloth to prevent contamination.
12. Remove the front retaining ring (if equipped).
13. Loosen the setscrews and remove the adjusting ring. Check for excessive wear. Check the shaft O.D. for any burrs and remove to prevent damage to the bracket bushings.
14. Remove the rotor from the bracket.
15. The back face of the rotor and the bracket face should be inspected for any deep scratches or wear. Inspect the bushings in the bracket for wear.
16. Do not remove the o-ring from the housing unless it is worn or damaged and needs replacement.

Section 16: Pump Assembly Procedure - 6110 & 7110 Pumps

Refer to Figure 3 (6110) & Figure 4 (7110).

1. Clean all parts thoroughly.
2. Install rotor in housing.
3. Position gaskets over mounting register of cover.

(6110 Pumps only) Set End Clearance. Gaskets are used to set and maintain proper internal clearances. These clearances depend on the size of the pump and are shown below. Note: Some Tuthill pumps are provided with non-standard clearances for use with high-viscosity or high-temperature fluids. Consult the factory for clearances of these pumps.

<u>Model</u>	<u>Minimum End Clearance</u>
6113	0.001" to 0.002" [0.03mm to 0.05mm]
6114	0.001" to 0.002" [0.03mm to 0.05mm]
6115	0.002" to 0.004" [0.05mm to 0.10mm]

Table 2 - End Clearance Values for 6110 Pumps

<u>Thickness</u>	<u>Color</u>
0.010" [0.25mm]	White
0.013" [0.33mm]	White
0.015" [0.38mm]	White

Table 3 - Available Gaskets for 6110 Pumps

4. Apply idler to cover and position in housing register. Align matching marks for proper location.
5. Install cover screws.
6. Once cover is installed, rotate the shaft to ensure smooth operation before proceeding.
7. Place pump on flat surface with the shaft facing upward. Check the condition of the o-ring in the groove on the bracket. Install new o-ring if required.
8. Place key into shaft keyway.
9. Lower inner magnet onto shaft until it bottoms onto shaft shoulder. Place retaining ring into upper retaining ring groove on shaft.
10. Place canister over inner magnet until the face of the canister flange bottoms onto the bracket. To insure easy assembly of canister over o-ring, place a small amount of lubricating oil on canister I.D. before assembly.
11. Position adapter securely on flat surface with the pump register end facing upward. Carefully lower the pump/inner magnet sub-assembly into the adapter register.
12. Once the pump/inner magnet sub-assembly is in place, fasten it to the adapter with screws.
13. Place the adapter plate on the motor register.
14. Place the motor on a flat surface with the shaft facing upward.
15. Place the key into motor shaft keyway.
16. Carefully lower outer magnet onto shaft until inside face of outer magnet is flush with the shaft. (see Figure 2).

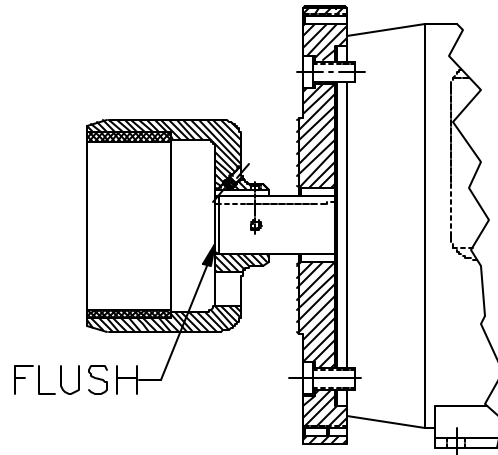

Figure 2 - Outer Magnet Position

17. Lock outer magnet onto shaft with set screws, installing the cone-pointed set screw first.
18. Install screws to fasten pump/adapter sub-assembly to motor.

Section 17: Pump Assembly Procedure - 6200 Pumps

Refer to Figure 5

1. Clean all parts thoroughly.
2. Install rotor in bracket.
3. Assemble housing & gasket over rotor head positioned on bracket register.
4. Set End Clearance. Gaskets are used to set and maintain proper internal clearances. These clearances depend on the size of the pump and are shown below. Note: Some Tuthill pumps are provided with non-standard clearances for use with high-viscosity or high-temperature fluids. Consult the factory for clearances of these pumps.

<u>Model</u>	<u>Minimum End Clearance</u>
6202	0.001" to 0.002" [0.03mm to 0.05mm]
6203	0.002" to 0.003" [0.05mm to 0.08mm]
6204	0.002" to 0.003" [0.05mm to 0.08mm]
6205	0.003" to 0.005" [0.08mm to 0.13mm]
6206	0.003" to 0.005" [0.08mm to 0.13mm]

Table 4 - End Clearance Values for 6200 Pumps

<u>Thickness</u>	<u>Color</u>
0.003" [0.08mm]	White
0.004" [0.10mm]	White
0.005" [0.13mm]	White

Table 5 - Available Gaskets for 6200 Pumps

5. Apply idler to cover and position in housing register. Align matching marks for proper location.
6. Install cover screws.
7. Once cover is installed, rotate the shaft to ensure smooth operation before proceeding.
8. Place pump on flat surface with the shaft facing upward. Check condition of o-ring in the groove on the bracket. Install new o-ring if required.
9. If equipped, place retaining ring into lower retaining ring groove on shaft.
10. Place key into shaft keyway.
11. Lower inner magnet onto shaft until it bottoms onto retaining ring or shaft shoulder. Place retaining ring into retaining ring groove on shaft
12. Place canister over inner magnet until the face of the canister flange bottoms onto the bracket. To insure easy assembly of canister over o-ring, place a small amount of lubricating oil on canister I.D. before assembly.
13. Position adapter securely on flat surface with the pump register end facing upward. Carefully lower the pump/inner magnet sub-assembly into the adapter register.

14. Once the pump/inner magnet sub-assembly is in place, fasten it to the adapter with screws from the cover end.
15. Place pump/inner magnet sub-assembly on a flat surface with the bearing housing register end facing upward.
16. Place key into bearing housing shaft keyway.
17. Place bearing housing sub-assembly on a flat surface with shaft facing upward.
18. Carefully lower outer magnet onto shaft until outer magnet bottoms onto shaft shoulder.
19. Lock outer magnet onto shaft with set screws, installing the cone-pointed set screw first.



CAUTION

DO NOT PLACE HAND OR FINGERS BETWEEN THE BRACKET AND ADAPTER. The magnets are extremely strong and will attract all metallic objects and can be the source of pinch points. Do not wear watches or other metallic jewelry when working with magnets. See warning on page 2.

Use jack screws to assemble models 6200 Series pumps. Jack screw kits are available as part number 2CMG 558 for models 6202, 6203 and 6204 and part number 5CMG 558 for models 6205 and 6206.

Failure to follow proper procedures or use appropriate tools could result in injury to you or damage to either personal property or the pump.

17. Install outer magnet assembly. Use jack screws to control the attraction of the inner and outer magnets:
 - a. Place (3) guide studs into adapter through the bracket screw clearance holes and hand-tighten.
 - b. Screw (1) jack screw into bearing housing until it extends to the end of the outer magnet.
 - c. Slowly unscrew jack screw from bearing housing. This will lower sub-assembly into adapter register.
 - d. After magnet bearing housing sub-assembly has been lowered into place, remove guide studs and jack screw.
18. Secure bearing housing sub-assembly into place with screws.
19. Proceed to couple completely assembled unit to drive.

Section 18: Pump Assembly Procedure - 6210 Pumps

Refer to Figure 6.

1. Clean all parts thoroughly.
2. Install rotor in bracket.
3. Assemble housing & gasket over rotor head positioned on bracket register.
4. Set End Clearance. Gaskets are used to set and maintain proper internal clearances. These clearances depend on the size of the pump and are shown below. Note: Some Tuthill pumps are provided with non-standard clearances for use with high-viscosity or high-temperature fluids. Consult the factory for clearances of these pumps.

<u>Model</u>	<u>Minimum End Clearance</u>
6212	0.001" to 0.002" [0.03mm to 0.05mm]
6213	0.002" to 0.003" [0.05mm to 0.08mm]
6214	0.002" to 0.003" [0.05mm to 0.08mm]
6215	0.003" to 0.005" [0.08mm to 0.13mm]
6216	0.003" to 0.005" [0.08mm to 0.13mm]

Table 6 - End Clearance Values for 6210 Pumps

<u>Thickness</u>	<u>Color</u>
0.003" [0.08mm]	White
0.004" [0.10mm]	White
0.005" [0.13mm]	White

Table 7 - Available Gaskets for 6210 Pumps

5. Apply idler to cover and position in housing register. Align matching marks for proper location.
6. Install cover screws.
7. Once cover is installed, rotate the shaft to ensure smooth operation before proceeding.
8. Place pump on flat surface with the shaft facing upward. Check condition of o-ring in the groove on the bracket. Install new o-ring if required.
9. If equipped, place retaining ring into lower retaining ring groove on shaft.
10. Place key into shaft keyway.
11. Lower inner magnet onto shaft until it bottoms onto retaining ring or shaft shoulder. Place retaining ring into retaining ring groove on shaft
12. Place canister over inner magnet until the face of the canister flange bottoms onto the bracket. To insure easy assembly of canister over o-ring, place a small amount of lubricating oil on canister I.D. before assembly.
13. Position adapter securely on flat surface with the pump register end facing upward. Carefully lower the pump/inner magnet sub-assembly into the adapter register.
14. Once the pump/inner magnet sub-assembly is in place, fasten it to the adapter with screws from the cover end.

15. Place the adapter plate on the motor register.
16. Place the motor on a flat surface with the shaft facing upward.
17. Place the key into motor shaft keyway.
18. Carefully lower outer magnet onto shaft until inside face of outer magnet is flush with the shaft. (see Figure 2).
19. Lock outer magnet onto shaft with set screws, installing the cone-pointed set screw first.



CAUTION

DO NOT PLACE HAND OR FINGERS BETWEEN THE BRACKET AND ADAPTER. The magnets are extremely strong and will attract all metallic objects and can be the source of pinch points. Do not wear watches or other metallic jewelry when working with magnets. See warning on page 2.

Use jack screws to assemble models 6210 Series pumps. Jack screw kits are available as part number 2CMG 558 for models 6212, 6213 and 6214 and part number 5CMG 558 for models 6215 and 6216.

Failure to follow proper procedures or use appropriate tools could result in injury to you or damage to either personal property or the pump.

20. Install pump head to motor. Use jack screws to control the attraction of the inner and outer magnets:
 - a. Place (3) guide studs into adapter through the bracket screw clearance holes and hand-tighten.
 - b. Screw (1) jack screw into bearing housing until it extends to the end of the outer magnet.
 - c. Slowly unscrew jack screw from bearing housing. This will lower sub-assembly into adapter register.
 - d. After magnet bearing housing sub-assembly has been lowered into place, remove guide studs and jack screw.
21. Secure pump head into place with screws.

Section 19: Pump Assembly Procedure - 6300, 7200 & 8200 Pumps

Refer to Figure 7.

1. Clean all parts thoroughly.
2. Install rotor in bracket.
3. Assemble housing & gasket to bracket with bracket screws.
4. Assemble idler, cover & gasket to housing with housing screws.
5. Install the thrust bearing, but do not tighten the set screws yet.
6. Set End Clearance.
 - a. The positioning of the adjusting ring is used to set and maintain proper internal clearances. These clearances depend on the size of the pump and are shown below.
 Note: Some Tuthill pumps are provided with non-standard clearances for use with high-viscosity or high-temperature fluids. Consult the factory for clearances of these pumps.

model	end clearance (inch)	end clearance (mm)
6302 / 6312	0.003 - 0.005	0.08 - 0.13
6303 / 6313	0.003 - 0.005	0.08 - 0.13
6304 / 6314	0.003 - 0.005	0.08 - 0.13
6305 / 6315	0.005 - 0.007	0.13 - 0.18
6306 / 6316	0.005 - 0.007	0.13 - 0.18
6307 / 6317	0.007 - 0.009	0.18 - 0.23
7202 / 7212	0.005 - 0.007	0.13 - 0.18
7203 / 7213	0.006 - 0.008	0.15 - 0.20
7204 / 7214	0.006 - 0.008	0.15 - 0.20
7205 / 7215	0.008 - 0.010	0.20 - 0.25
7206 / 7216	0.008 - 0.010	0.20 - 0.25
7207 / 7217	0.011 - 0.013	0.28 - 0.33
8202 / 8212	0.003 - 0.005	0.08 - 0.13
8203 / 8213	0.003 - 0.005	0.08 - 0.13
8204 / 8214	0.003 - 0.005	0.08 - 0.13
8205 / 8215	0.005 - 0.007	0.13 - 0.18
8206 / 8216	0.005 - 0.007	0.13 - 0.18
8207 / 8217	0.007 - 0.009	0.18 - 0.23

Table 8 - End Clearance Values

- b. Obtain a feeler gage with a thickness equal to the desired end clearance.
 - c. Insert the feeler gage through the ports, between the idler and the rotor.
 - d. Push the rotor towards the cover, and tighten the thrust bearing set screws.
 - e. Remove the feeler gage, and rotate the shaft to ensure smooth operation before proceeding.
7. Place pump on flat surface with the shaft facing upward. Check condition of o-ring in the groove on the bracket. Install new o-ring if required.

8. If equipped, place retaining ring into lower retaining ring groove on shaft.
9. Place key into shaft keyway.
10. Lower inner magnet onto shaft until it bottoms onto retaining ring or shaft shoulder. Place retaining ring into retaining ring groove on shaft
11. Place canister over inner magnet until the face of the canister flange bottoms onto the bracket. To insure easy assembly of canister over o-ring, place a small amount of lubricating oil on canister I.D. before assembly.
12. Position adapter securely on flat surface with the pump register end facing upward. Carefully lower the pump/inner magnet sub-assembly into the adapter register.
13. Once the pump/inner magnet sub-assembly is in place, fasten it to the adapter with screws.
14. Place pump/inner magnet sub-assembly on a flat surface with the bearing housing register end facing upward.
15. Place key into bearing housing shaft keyway.
16. Place bearing housing sub-assembly on a flat surface with shaft facing upward.
17. Carefully lower outer magnet onto shaft until outer magnet bottoms onto shaft shoulder.
18. Lock outer magnet onto shaft with set screws, installing the cone-pointed set screw first.



CAUTION

DO NOT PLACE HAND OR FINGERS BETWEEN THE BRACKET AND ADAPTER. The magnets are extremely strong and will attract all metallic objects and can be the source of pinch points. Do not wear watches or other metallic jewelry when working with magnets. See warning on page 2.

Use jack screws to assemble models 6300, 7200 & 8200 Series pumps. Jack screw kits are available as part number 2CMG 558 for models 6302-4, 7202-4 & 8202-4 and part number 5CMG 558 for models 6305-6, 7205-6 & 8205-6.

Failure to follow proper procedures or use appropriate tools could result in injury to you or damage to either personal property or the pump.

19. Install outer magnet assembly. Use jack screws to control the attraction of the inner and outer magnets:
 - a. Place (3) guide studs into adapter through the bracket screw clearance holes and hand-tighten.
 - b. Screw (1) jack screw into bearing housing until it extends to the end of the outer magnet.
 - c. Slowly unscrew jack screw from bearing housing. This will lower sub-assembly into adapter register.

- d. After magnet bearing housing sub-assembly has been lowered into place, remove guide studs and jack screw.
20. Secure bearing housing sub-assembly into place with screws.
21. Proceed to couple completely assembled unit to drive.

Section 20: Pump Assembly Procedure - 6310, 7210 & 8210 Pumps
--

Refer to Figure 8.

1. Clean all parts thoroughly.
2. Install rotor in bracket.
3. Assemble housing & gasket to bracket with bracket screws.
4. Assemble idler, cover & gasket to housing with housing screws.
5. Install the adjusting ring, but do not tighten the set screws yet.
6. Set End Clearance.
 - a. The positioning of the adjusting ring is used to set and maintain proper internal clearances. These clearances depend on the size of the pump and are shown in Table 8. Note: Some Tuthill pumps are provided with non-standard clearances for use with high-viscosity or high-temperature fluids. Consult the factory for clearances of these pumps.
 - b. Obtain a feeler gage with a thickness equal to the desired end clearance.
 - c. Insert the feeler gage through the ports, between the idler and the rotor.
 - d. Push the rotor towards the cover, and tighten the thrust bearing set screws.
 - e. Remove the feeler gage, and rotate the shaft to ensure smooth operation before proceeding.
7. Place pump on flat surface with the shaft facing upward. Check condition of o-ring in the groove on the bracket. Install new o-ring if required.
8. If equipped, place retaining ring into lower retaining ring groove on shaft.
9. Place key into shaft keyway.
10. Lower inner magnet onto shaft until it bottoms onto retaining ring or shaft shoulder. Place retaining ring into retaining ring groove on shaft
11. Place canister over inner magnet until the face of the canister flange bottoms onto the bracket. To insure easy assembly of canister over o-ring, place a small amount of lubricating oil on canister I.D. before assembly.

12. Position adapter securely on flat surface with the pump register end facing upward. Carefully lower the pump/inner magnet sub-assembly into the adapter register.
13. Once the pump/inner magnet sub-assembly is in place, fasten it to the adapter with screws.
14. Place the adapter plate on the motor register.
15. Place the motor on a flat surface with the shaft facing upward.
16. Place the key into motor shaft keyway.
17. Carefully lower outer magnet onto shaft until inside face of outer magnet is flush with the shaft. (see Figure 2).
18. Lock outer magnet onto shaft with set screws, installing the cone-pointed set screw first.



CAUTION

DO NOT PLACE HAND OR FINGERS BETWEEN THE BRACKET AND ADAPTER. The magnets are extremely strong and will attract all metallic objects and can be the source of pinch points. Do not wear watches or other metallic jewelry when working with magnets. See warning on Page 2.

Use jack screws to assemble models 6310, 7210 & 8210 Series pumps. Jack screw kits are available as part number 2CMG 558 for models 6312-4, 7212-4 & 8212-4 and part number 5CMG 558 for models 6315-6, 7215-6 & 8215-6.

Failure to follow proper procedures or use appropriate tools could result in injury to you or damage to either personal property or the pump.

19. Install pump head to motor. Use jack screws to control the attraction of the inner and outer magnets:
 - a. Place (3) guide studs into adapter through the bracket screw clearance holes and hand-tighten.
 - b. Screw (1) jack screw into bearing housing until it extends to the end of the outer magnet.
 - c. Slowly unscrew jack screw from bearing housing. This will lower sub-assembly into adapter register.
 - d. After magnet bearing housing sub-assembly has been lowered into place, remove guide studs and jack screw.
20. Secure pump head into place with screws.

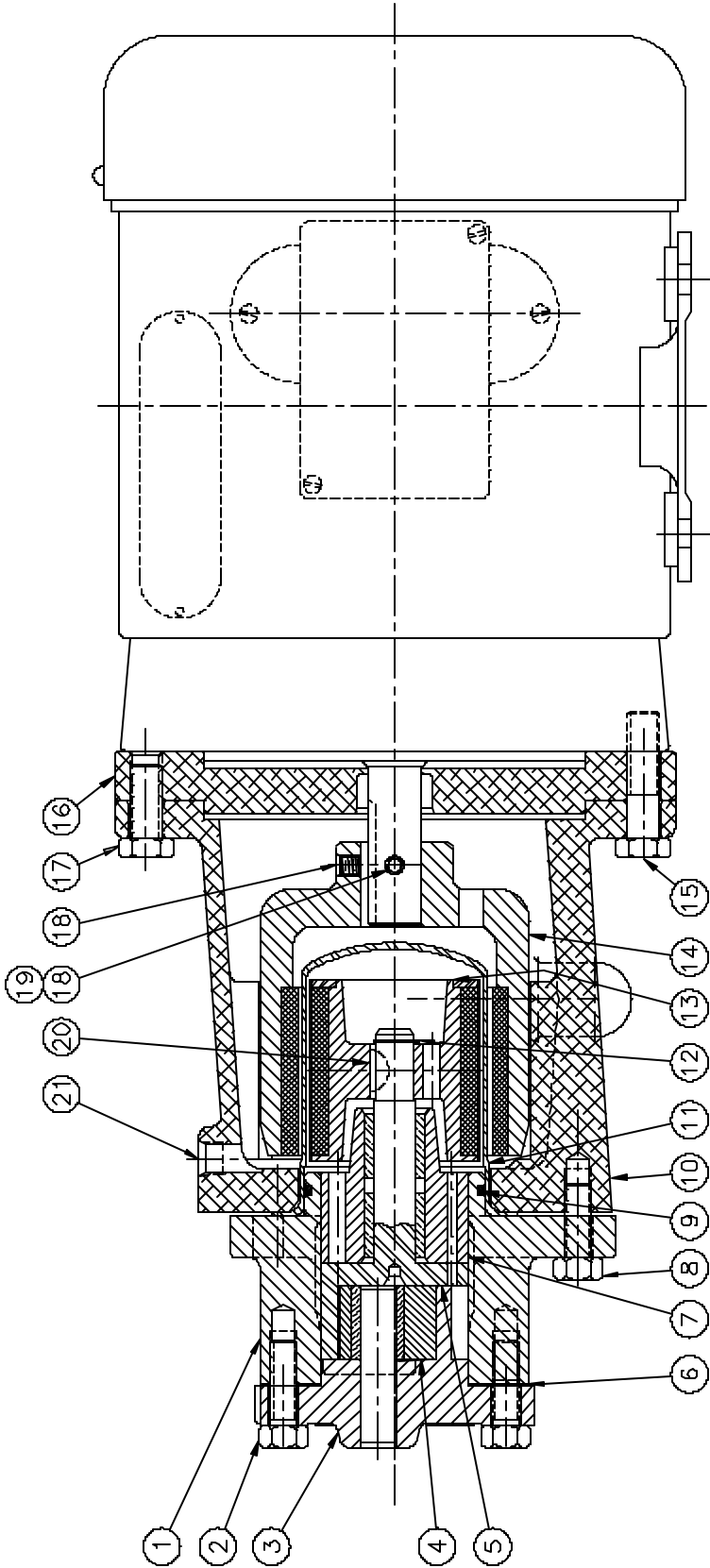
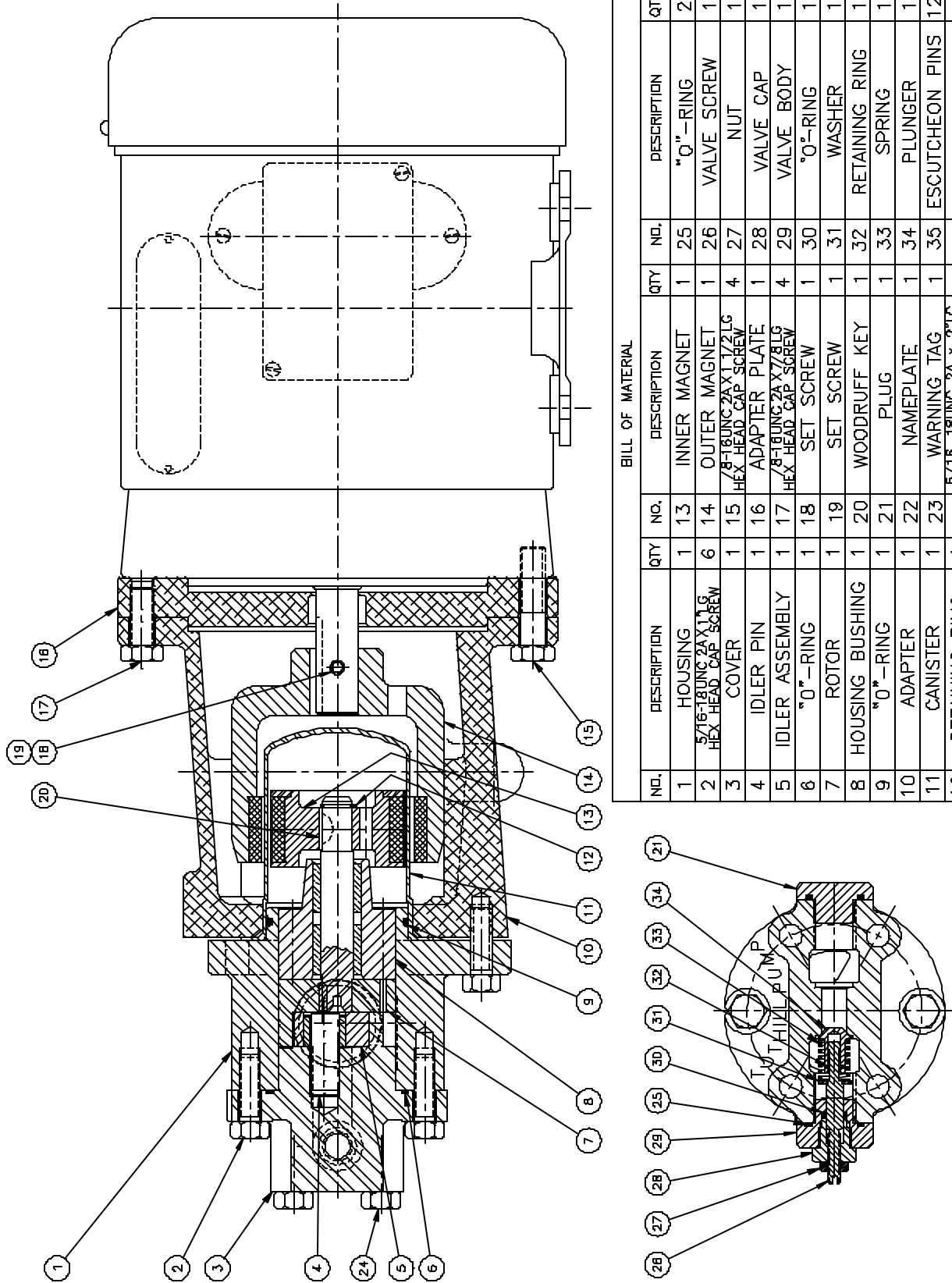

Figure 3 - Typical 6110 Series Pump

BILL OF MATERIAL					
NO.	DESCRIPTION	QTY	NO.	DESCRIPTION	QTY.
1	HOUSING	1	12	RETAINING RING	1
2	5/16-18UNC 2A X 1 1/2 LG HEX HEAD CAP SCREW	6	13	INNER MAGNET	1
3	COVER & PIN ASSY.	1	14	OUTER MAGNET	1
4	IDLER & BUSHING	1	15	3/8-18UNC 2A X 1 1/2 LG HEX HEAD CAP SCREW	4
5	ROTOR	1	16	ADAPTER PLATE	1
6	GASKET	1	17	3/8-18UNC 2A X 7/8 LG HEX HEAD CAP SCREW	4
7	HOUSING BUSHING	1	18	SET SCREW	2
8	5/16-18UNC 2A X 7/8 LG HEX HEAD CAP SCREW	4	19	SET SCREW	1
9	O-RING	1	20	WOODRUFF KEY	1
10	ADAPTER	1	21	1/8 NPT PIPE PLUG	1
11	CANISTER	1			



BILL OF MATERIAL

NDL	DESCRIPTION	QTY	NO.	DESCRIPTION	QTY	NO.	DESCRIPTION	QTY
1	HOUSING	1	13	INNER MAGNET	1	25	"O"-RING	2
2	5/16-18UNC 2A X 1.1 LG HEX HEAD CAP SCREW	6	14	OUTER MAGNET	1	26	VALVE SCREW	1
3	COVER	1	15	7/8-18UNC 2A X 1.72 LG HEX HEAD CAP SCREW	4	27	NUT	1
4	IDLER PIN	1	16	ADAPTER PLATE	1	28	VALVE CAP	1
5	IDLER ASSEMBLY	1	17	7/8-18UNC 2A X 7/8 LG HEX HEAD CAP SCREW	4	29	VALVE BODY	1
6	"O"-RING	1	18	SET SCREW	1	30	"O"-RING	1
7	ROTOR	1	19	SET SCREW	1	31	WASHER	1
8	HOUSING BUSHING	1	20	WOODRUFF KEY	1	32	RETAINING RING	1
9	"O"-RING	1	21	PLUG	1	33	SPRING	1
10	ADAPTER	1	22	NAMEPLATE	1	34	PLUNGER	1
11	CANISTER	1	23	WARNING TAG	1	35	ESCUTCHEON PINS	12
12	RETAINING RING	1	24	5/16-18UNC 2A X 2.2 LG HEX HEAD CAP SCREW	4	36	WARNING TAG	1

Figure 4 - Typical 7110 Series Pump

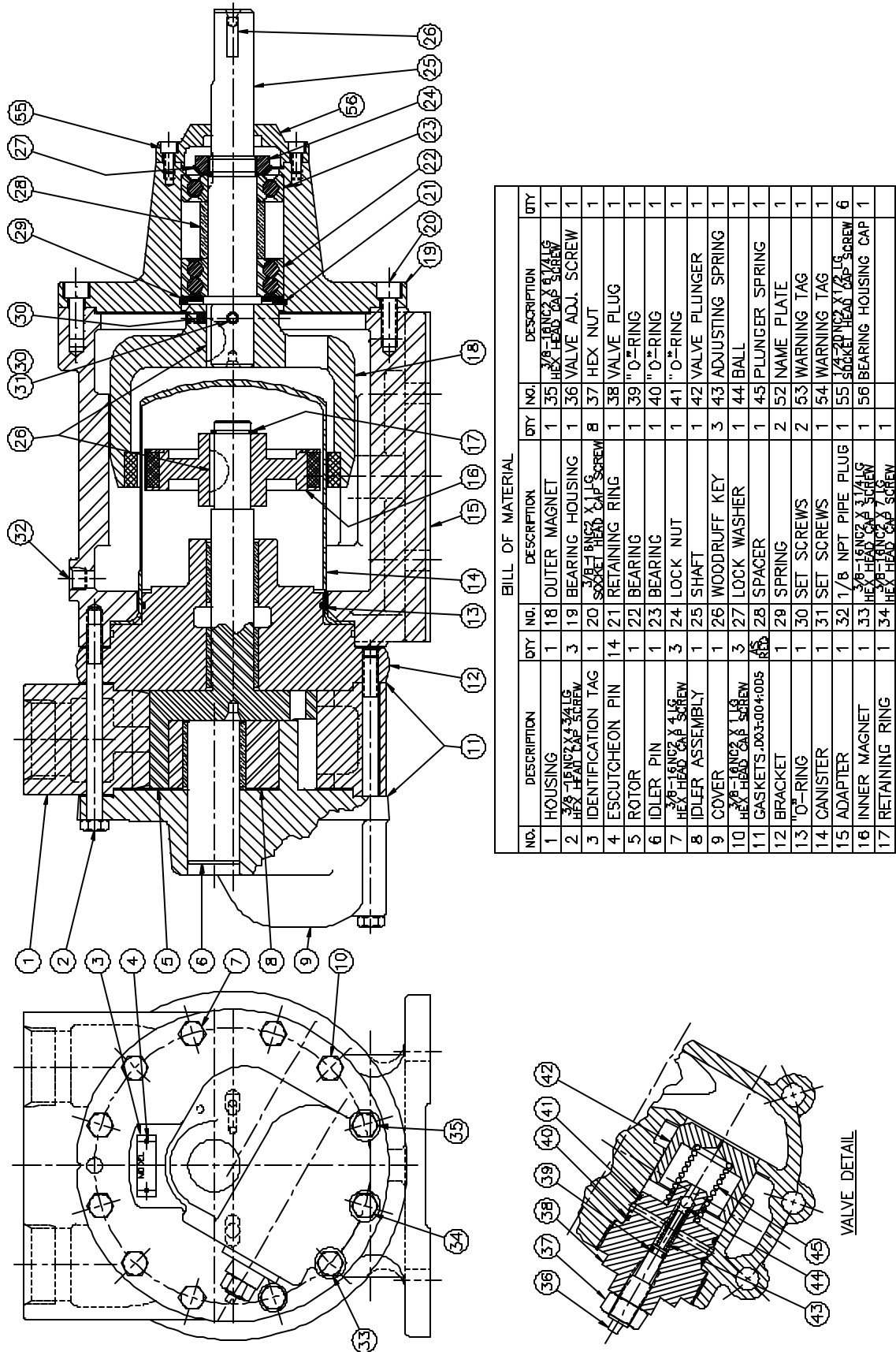
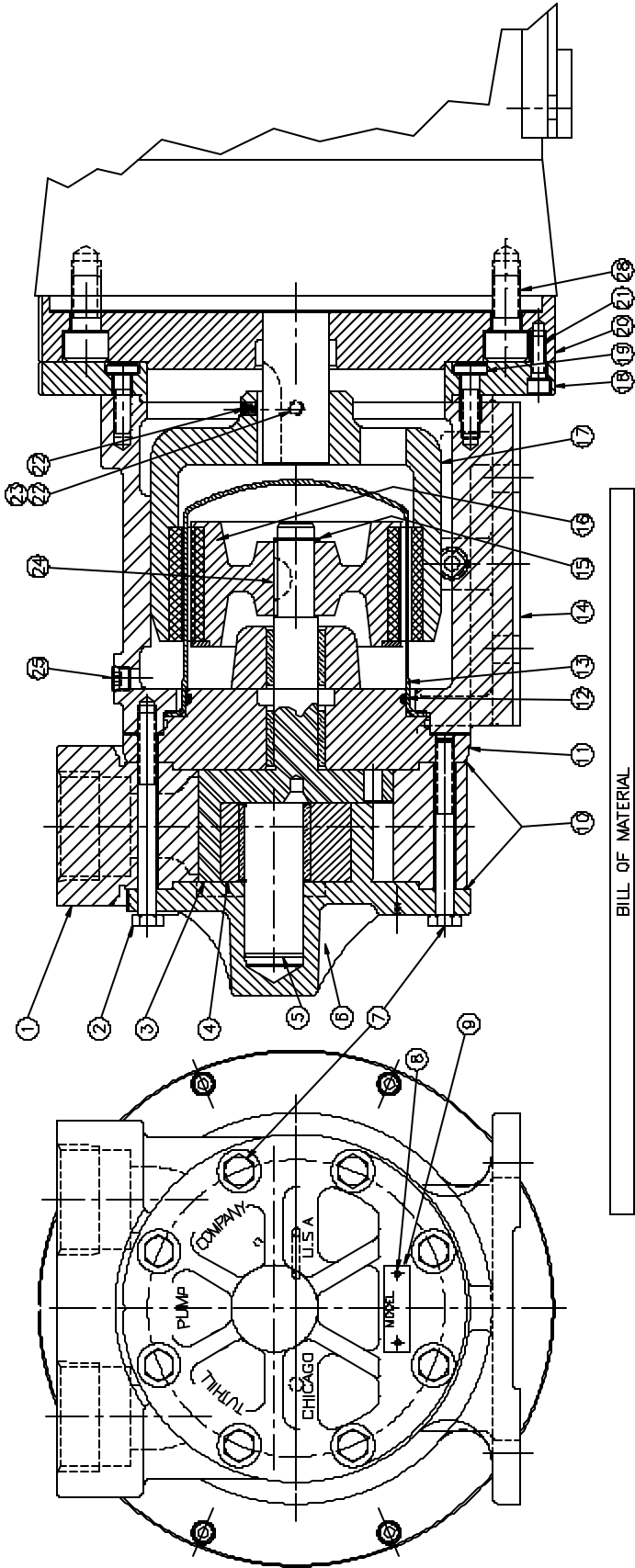

Figure 5 - Typical 6200 Series Pump



BILL OF MATERIAL

NO.	DESCRIPTION	QTY	NO.	DESCRIPTION	QTY	NO.	DESCRIPTION	QTY
1	HOUSING	1	11	BRACKET	1	21	1/4 - 20 UNF-2A x 3/4 LG	8
2	5/16 - 18 UNF-2A x 1/2 LG H.H.C.S.	4	12	O-RING	1	22	SET SCREW	2
3	ROTOR	1	13	CANISTER	1	23	SET SCREW	1
4	IDLER ASSEMBLY	1	14	ADAPTER	1	24	WODDRUFF KEY	1
5	IDLER PIN	1	15	RETAINING RING	1	25	NAME PLATE	1
6	COVER	1	16	INNER MAGNET	1	26	WARNING TAG	2
7	5/16 - 18 UNF-2A x 3/4 LG	4	17	OUTER MAGNET	1	27	PIPE PLUG 3/8-27NPT	1
8	ESCUTCHEON PIN	10	18	ADAPTER PLATE	1	28	1/2 - 18 UNF-2A x 1 LG E.H.C.S.	4
9	IDENTIFICATION TAG	1	19	5/16 - 18 UNF-2A x 1 LG LOW HEAD S.H.T.S.	8			
10	GASKETS 003-1004-005	8	20	ADAPTER PLATE	1			

Figure 6 - Typical 6210 Series Pump

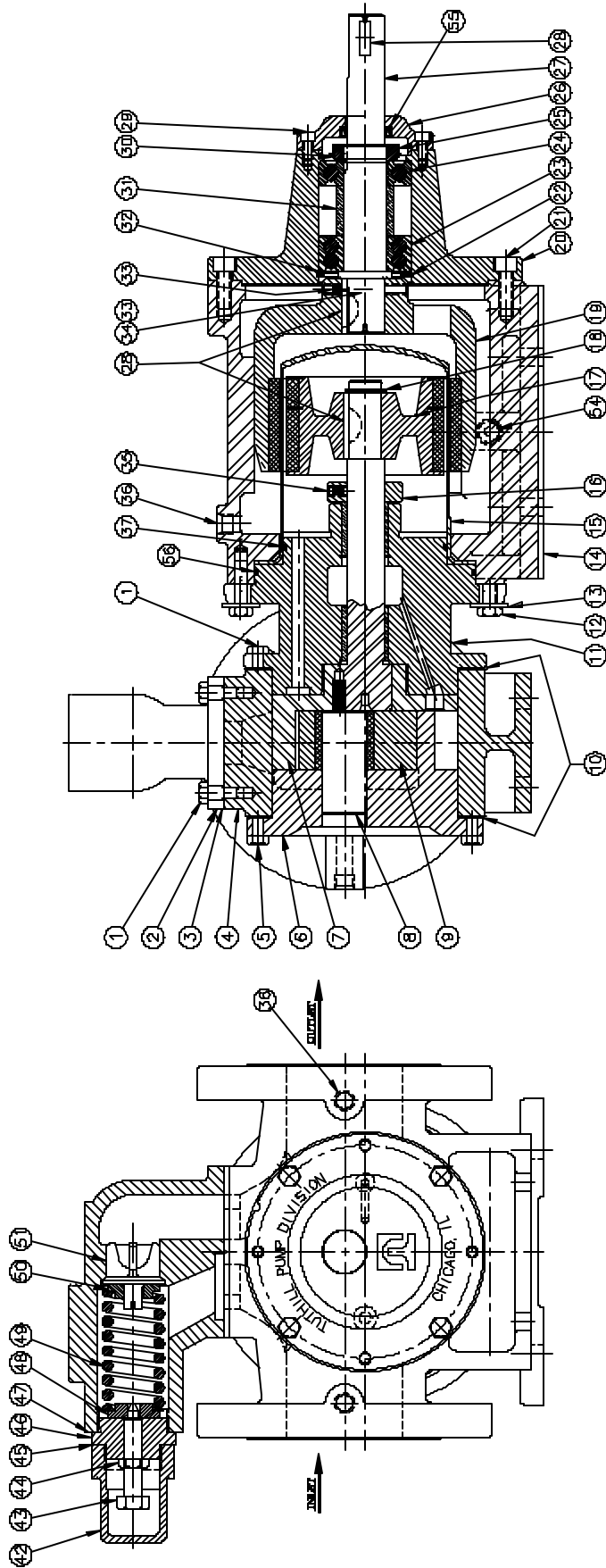

BILL OF MATERIAL

No.	DESCRIPTION	QTY	NO.	DESCRIPTION	QTY	NO.	DESCRIPTION	QTY	NO.	DESCRIPTION	QTY
1	1/2" X 3/8" NPT SCREW	1	29	SPACER	1	43	VALVE ADJ. SCREW	1			
2	RELIEF VALVE BODY	1	30	LOCK WASHER	1	44	JAM NUT	1			
3	GASKET	1	31	INNER MAGNET	1	45	VALVE CAP GASKET	1			
4	HOUSING	1	32	RETAINING RING	1	46	BONNET	1			
5	1/2" X 3/8" NPT SCREW	4	33	SET SCREWS	2	47	BONNET GASKET	1			
6	COVER	1	34	BEARING HOUSING	1	48	OUTER SPRING GUIDE	1			
7	ROTOR ASSEMBLY	1	35	SET SCREW	3	48	VALVE SPRING	1			
8	IDLER PIN	1	36	1/4" NPT PIPE PLUG	3	50	INNER SPRING GUIDE	1			
9	IDLER ASSEMBLY	1	37	O-RING	1	51	POPPET	1			
10	GASKET	2	38	ESCUTCHEON PIN	12	52	WARNING TAG	1			
11	BRACKET	1	39	NAMEPLATE	1	53	CAUTION TAG	1			
12	1/2" X 3/8" NPT SCREW	4	40	WARNING TAG	1	54	3/8" NPT PIPE PLUG	2			
13	WASHER	4	41	WARNING TAG	1	55	SEAL	1			
14	ADAPTER	1	42	WOODRUFF KEY	3	56	O-RING	1			

Figure 7 - Typical 6300 / 7200 / 8200 Series Pump

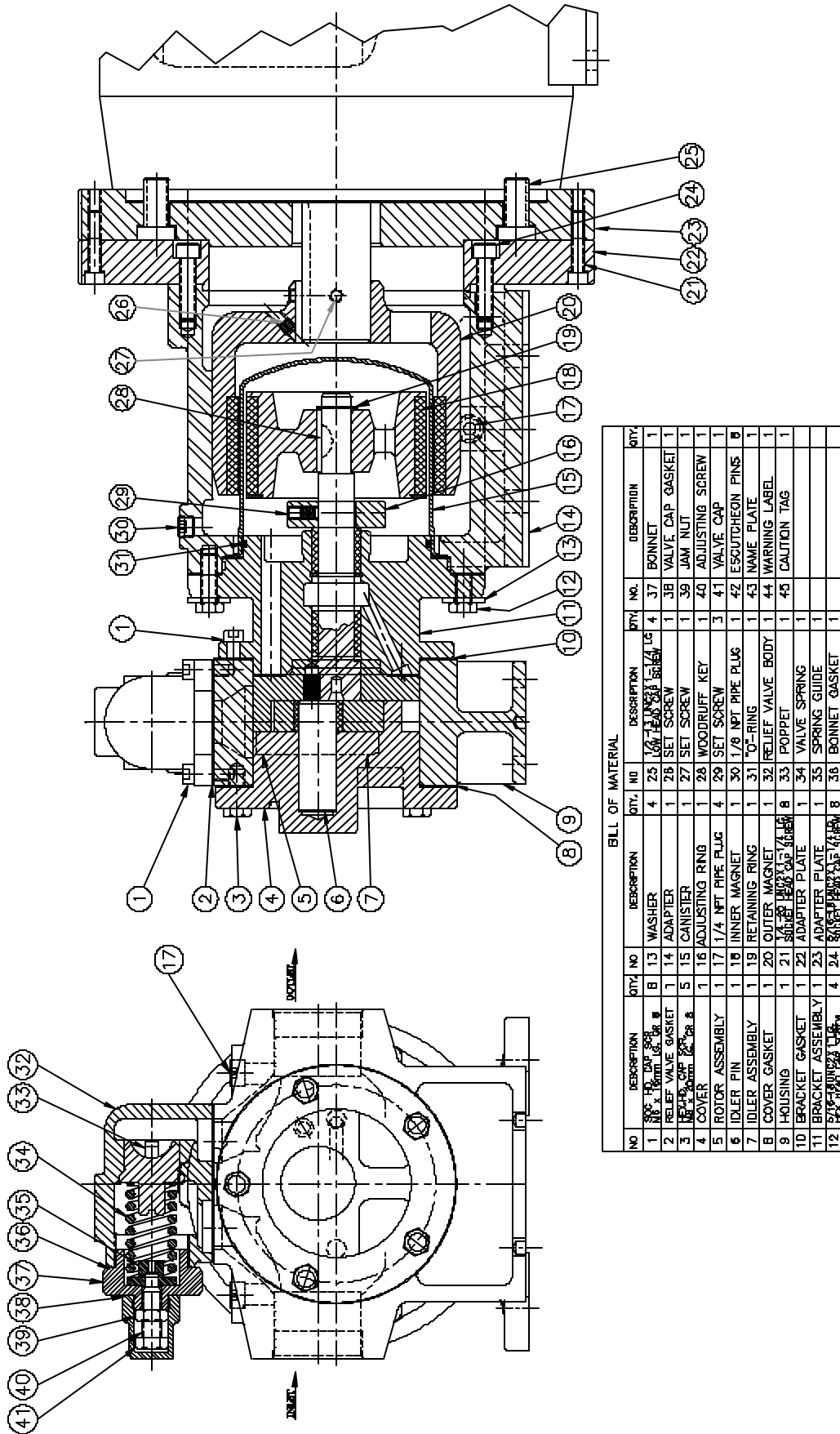

Figure 8 - Typical 6310 / 7210 / 8210 Series Pump

Section 21: Troubleshooting

1. Problem: No fluid is delivered.

- a. Power is not on.
- b. Net positive suction head available (NPSHa) is lower than required for the vapor pressure of the liquid pumped. You should calculate NPSHa and redesign piping, if necessary.
- c. Leaks in suction line or port passages. These can be detected by submerging pressure line from discharge side of pump into a pail of liquid where the air will be seen in the form of bubbles.
- d. Direction of shaft rotation is incorrect.
- e. Magnetic coupling has decoupled. Check for excessive pressure/speed problems.
- f. Relief valve setting is too low. Liquid is discharging through the by-pass port.

2. Problem: Capacity is too low.

- a. Air leaks in suction line.
- b. Suction losses are too high. The suction lift is too great or the suction line is too small or too long. This can be detected by installing a vacuum gauge directly at the pump suction. The maximum vacuum at the pump suction should never exceed 15" of mercury. Vaporization caused by higher vacuums will generally result in capacity drop off. Redesign suction conditions .
- c. Pump speed is too slow.
- d. Strainer too small or obstructed.
- e. Suction pipe or port not immersed in liquid deep enough
- f. Piping improperly installed permitting air pocket to form in the pump.
- g. Increased clearances or wear in the pump will sometimes cause the pump to deliver an insufficient supply of liquid. This may be corrected by reducing the thickness of the cover gaskets. A folded gasket or a slight amount of dirt can exaggerate the problem and cause leakage. Refer to Assembly Procedure section for minimum end clearances.

3. Problem: Pump works spasmodically.

- a. Leaky suction lines.
- b. Suction conditions vary.
- c. Air or vapor in liquid.

4. Problem: Excessive power draw.

- a. Pressure too high.
- b. Liquid more viscous than originally expected.

- c. Suction or discharge lines obstructed.
- d. Insufficient horsepower.
- e. Mechanical defects:
 - i. Drive shaft and pump are misaligned.
 - ii. Pump is binding due to insufficient end clearance.
 - iii. Pump shaft is bent.
 - iv. Misalignment within pump due to bad piping or poor installation, causing strain or distortion.

5. Problem: Pump is noisy.

- a. Pump is cavitating due to inadequate suction conditions.
- b. Misalignment of coupling.
- c. Coupling set too close to pump.
- d. Vibration of pump due to worn or bent shaft.
- e. Air leaks on suction side of pump or air entrainment in fluid.

6. Problem: Pump leaks.

- a. Bolts need tightening, allowing gaskets or o-rings to leak.
- b. Gaskets or o-rings are damaged.
- c. Damage has occurred to the canister.

Section 22: Material Returns

If it becomes necessary to return a pump to the factory, a Return Goods Authorization (RGA) must be obtained from either your local Authorized Distributor or our Alsip plant. No RGA can be issued until a completed Material Safety Data Sheet (MSDS) has been forwarded to our Alsip plant and return of the pump approved.

- Tuthill pumps are precision built and must be handled with care.
- Pumps must be drained of all fluid and the ports plugged to prevent foreign material from getting into the pump.
- Pumps must be packaged securely to prevent damage while in transit.

Notes:



TUTHILL
Pump Group

12500 South Pulaski Road
Alsip, Illinois USA 60803
Tel 708 389-2500 Fax 708 388-0869
email: tuthillpump@tuthill.com
www.tuthill.com