



**TUTHILL  
Pump Group**

12500 South Pulaski Road  
Alsip, Illinois USA 60803  
Tel 708 389-2500 Fax 708 388-0869  
email: [tuthillpump@tuthill.com](mailto:tuthillpump@tuthill.com)  
[www.tuthill.com](http://www.tuthill.com)

# **Installation and Service Instructions**

## **4000 Series Pumps**

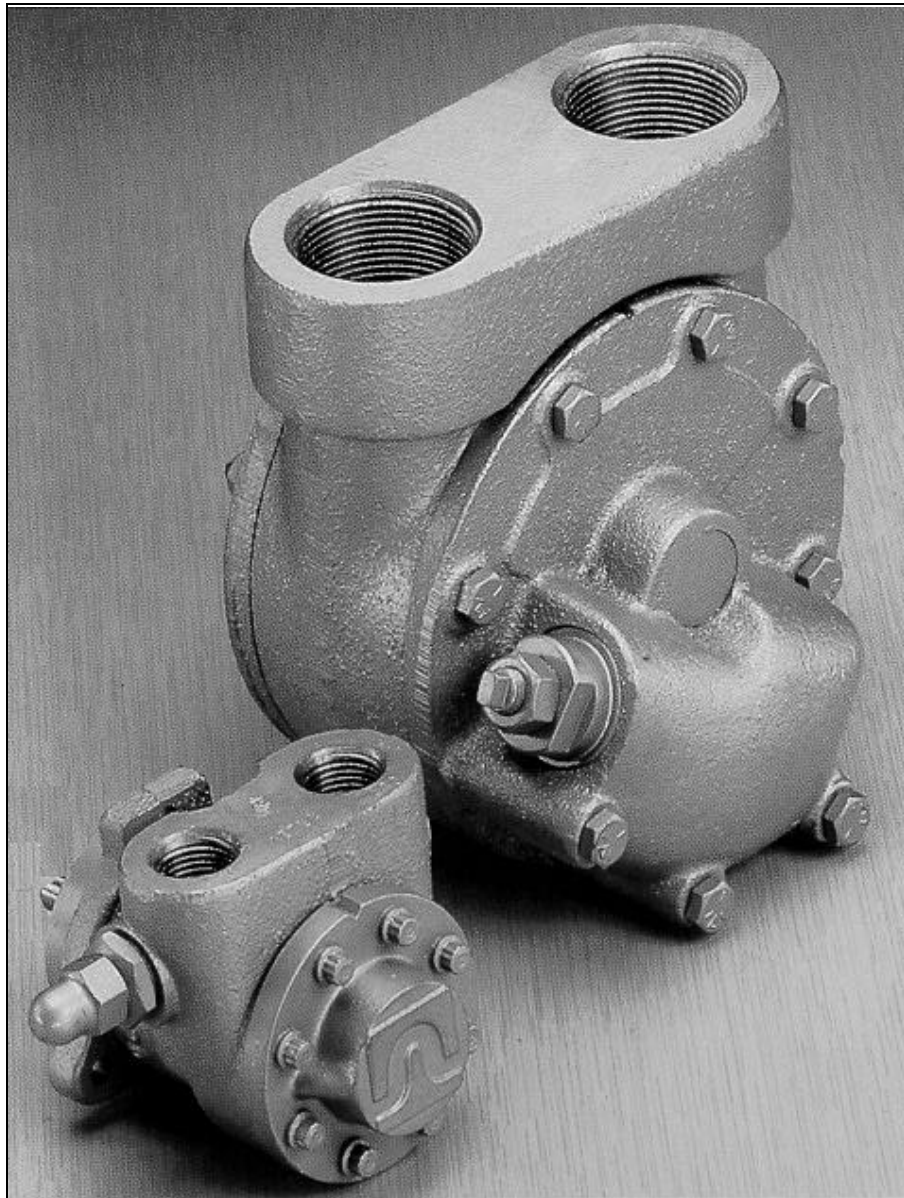

**General Description****4100/4120 Models**

Tuthill's 4100 and 4120 pumps are available in five sizes each, with nominal capacities ranging from 0.5 to 14 gallons per minute (1.9 to 53 liters per minute.) These pumps can handle inlet pressure to 250 psi (17 bar) and differential pressure to 500 psi (34 bar.) (Differential pressure is limited to 300 psi (20 bar) in models 4108/4128). These pumps are self-priming and particularly suited to handle liquids of 35 to 1000 SSU (2 to 200 centipoise.) Higher viscosities can be handled at reduced speeds.

A mounting foot is available as an option, as is an internal relief valve. These pumps are bi-rotational (unless outfitted with the optional relief valve) and designed for direct drive at standard motor speeds, with modifications available for indirect drive.

Model 4100 pumps include a mechanical seal and carbon graphite idler and housing bushings.

Model 4120 pumps include an abrasion resistant mechanical seal, carbon graphite idler bushing, ceramic housing bushing, Tutrided cover and induction hardened rotor.

**4200/4220 Models**

Models 4200 and 4220 are available in five sizes each, ranging in nominal capacity from 6 to 84 gpm (23 to 318 lpm.) Maximum inlet pressure capability is 25 psi (2 bar) and maximum differential pressure capability is 100 psi (7 bar.)

These pumps have an integrally-cast mounting foot, are suitable for driving at direct motor speeds and will pump equally well in either direction of rotation (unless supplied with the optional relief valve.) They are equipped with aluminum packing and an adjustable packing gland.

Model 4200 pumps include carbon graphite idler and bracket bushings.

Model 4220 pumps include a carbon graphite idler bushing, ceramic bracket bushing, Tutrided cover and induction hardened rotor.

**4300/4320 Models**

Models 4300 and 4320 are flange mount pumps with mechanical seal. They are bi-rotational, unless equipped with the optional internal relief valve. They are available in five sizes each with capacities from 6 to 84 gpm (23 to 318 lpm.) These pumps can handle inlet pressure to 250 psi (17 bar), maximum discharge pressure to 300 psi (20 bar), and differential pressure to 150 psi (10 bar.) A mounting foot is optional.

Model 4300 pumps include a mechanical seal, carbon graphite idler and bracket bushings.

Model 4320 pumps include an abrasion resistant mechanical seal, carbon graphite idler bushing, ceramic bracket bushing, Tutrided cover, induction hardened rotor and adjustable thrust bearing feature.

<b>The Pumping Principle</b>
------------------------------

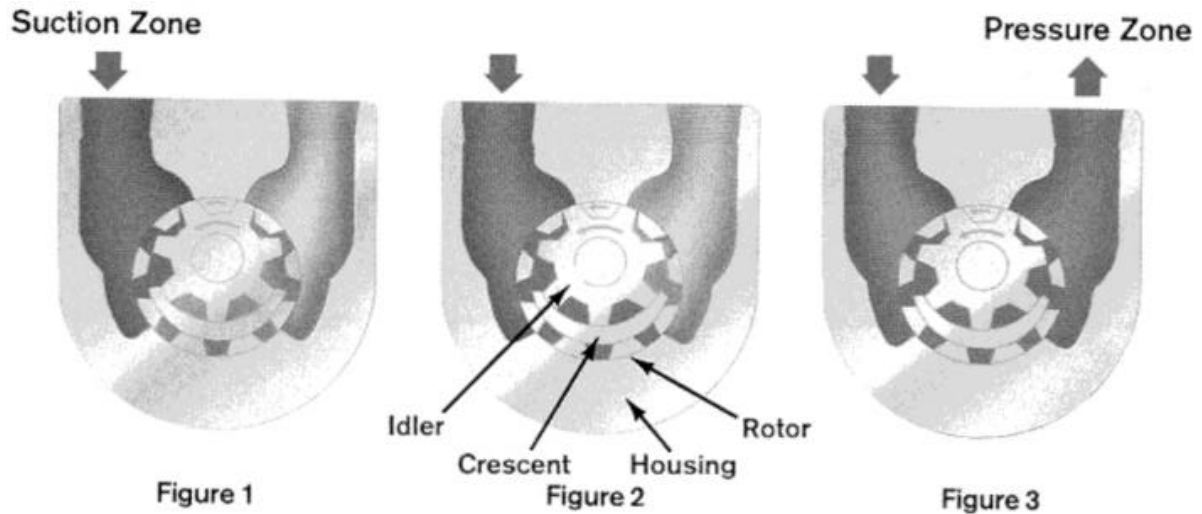

Tuthill Series 4000 cast iron pumps employ the internal gear pumping principle. There are only two moving parts. Pumping action is based on a rotor, idler gear and crescent-shaped partition cast integral with the cover.

Power applied to the rotor is transmitted to the idler gear with which it meshes. The space between the outside diameter of the idler and the inside diameter of the rotor is sealed by the crescent.

As the pump starts, the teeth come out of mesh, increasing the volume. This creates a partial vacuum, drawing the liquid into the pump through the suction port.

The liquid fills the spaces between the teeth of the idler and the rotor and is carried past the crescent partition through the pressure side of the pump.

When the teeth mesh on the pressure side, the liquid is forced from the spaces and out through the discharge port.

**WARNING**

Failure to follow these instructions could result in serious bodily injury or death.

Do not attempt to work on any Tuthill pump installation before completing the following steps:

Disconnect the drive so that it cannot be started while work is being performed.

Review the Material Safety Data Sheet (MSDS) applicable to the fluid being pumped to determine its characteristics and the precautions necessary to ensure safe handling.

Vent all pressure within the pump through the suction or discharge lines.

All Tuthill pumps contain residual hydraulic oil from the factory production test. Determine if this is compatible with the fluid you are pumping. If the fluid is incompatible, consult the factory.

**Location**

Most Tuthill Series 4000 pumps are required to develop 25" mercury vacuum at 0 psi on factory test. While these pumps will develop as high as 27" of vacuum, it is sound engineering practice to avoid extreme vacuum whenever possible. Select a pipe size to reduce line friction loss to a minimum.

The pump should be located as close to the source of supply as conditions permit and if possible, below the level of the liquid in the reservoir. When necessary to locate the pump in a pit, provisions should be made to safeguard against flooding. Care must be taken to properly support the suction and discharge piping so that no strain is put on the pump due to either weight or expansion. Piping strain can result in misalignment, hot bearings, worn couplings, and vibration. It is important that the piping used be clean and free of chips and scales.

**Proper Installation**

Unsatisfactory pump installations are usually characterized by poor suction conditions for the specific liquid being handled. Suction conditions should be minimized to prevent vaporization of the liquid. If vacuum conditions force the liquid to vaporize, cavitation will occur, resulting in loss of capacity, premature wear and noisy operation.

When handling high viscosity liquids, the speed of the pump must be reduced and the size of the lines increased to prevent cavitation. Consult the factory for NPSH requirements.

Note: Pipe line friction increases at a rapid rate with an increase in viscosity. For a given pump and motor, larger pipe lines are necessary to maintain the same pump pressure when changing from a thin fluid to a thick one.

Most Tuthill Series 4000 pumps are supplied with both ports on the same plane. Pumps with this type of porting arrangement should always be installed with the ports facing upward to insure proper priming. If it is necessary to install the pump with the ports pointing to either side, it is recommended that the top port be the suction port. This will prevent gravity induced drainage of fluid through the suction port. When pipes are installed, an inverted "U" bend should be incorporated into the suction line close to the pump for priming purposes.

The multiple port arrangement in the 4108/4128 pumps offers flexibility but is limited to some common sense restrictions. There is an inlet and an outlet side to the pump. There must always be at least one pipe on each side. Units ordered with the side port option (modification S) are shipped with port plugs in the top ports. To adapt to a 90° porting arrangement, the plugs must be relocated.

Because of its size, the 4108/4128 will not mount onto a NEMA 48 frame motor unless the motor is shimmed approximately 1/4".

Viewing the pump from the shaft end, the inlet port is on the right for clockwise rotation and on the left for counter-clockwise rotation. On pumps with built in relief valves, the adjusting screw of the valve must always be located on the suction side of the pump.

Pumps should be filled with fluid at installation and never be allowed to run dry.

Every pump installation should have a good foundation. Its structure should be sufficiently strong to hold the pump rigid and to absorb any strain or shock that may be encountered. The installation should be leveled, checked for proper piping alignment, and then fastened securely.

**Method of Drive**

Direct drive through a traditional flexible coupling is recommended. However, do not expect the flexible coupling to compensate for misalignment. Contact the coupling manufacturer to determine the maximum amount of misalignment to which the coupling can be subjected.

Tuthill Series 4000 pumps can be driven in either direction of rotation, unless outfitted with an internal relief valve. The seal chamber communicates with the neutral zone and therefore the seal is subjected to approximately one half of the discharge pressure.

All pump and motor units must be properly aligned during assembly and periodically checked, since misalignment may occur later due to abuse or other conditions. Pipe strain can force the pump and motor shafts out of alignment. Therefore, all piping to the pump must be properly supported. Do not allow the pump to act as a pipe support.

Provide for proper expansion of pipes when handling hot liquids. Allow the pump to reach operating temperature slowly. Rapid temperature change can result in damage to the cast iron components. Recheck the alignment.

Never align a pump and motor supplied with a pin type coupling without first removing the pins.

Never depend upon sight or feel. Use proper gauges when aligning the pump.

Never operate the pump without all guards in place.

**Relief Valve Protection**

All Series 4000 models are positive displacement pumps. As the pump rotates, liquid is positively delivered to the discharge side of the pump. If the discharge line is closed off, pressure will increase until the drive stalls and/or fails, the pump breaks or ruptures, or the piping bursts. To prevent this from happening, the use of a pressure relief valve is required. A relief valve that directs the flow back to the supply tank is recommended.

The internal relief valve available on Series 4000 pumps is designed for overpressure protection only. It is not intended as a flow control device or for any similar use. Continuous operation of the relief valve will result in excessive heat buildup within the pump cavity, which could cause serious internal damage. Make certain the adjusting screw of the relief valve is located on the suction side of the pump.

Tuthill specifies relief valve settings based on full-bypass pressure, where 100% of the pump flow is recirculating through the valve. It is important to know that the valve will be partially open at pressures below the full-bypass pressure. The difference between the partially open pressure and the full-bypass pressure is dependent on pump speed and fluid viscosity.

If an internal relief valve has not been supplied with the pump, some other means of protection must be utilized. These include in-line safety relief valves, pressure shutdown switches or other similar devices.

**4100 Series**

Unless otherwise specified at the time of order, all 4100/4120 pumps are supplied with the standard spring, with a range of 55-120 psi (4 to 8 bar), set to relieve at 55 psi (4 bar) full-bypass. The standard spring range in the 4108/4128 is 40-70 psi (3 to 5 bar.)

To adjust the relief valve setting within the range of a given spring's capability:

1. Remove the acorn nut. (Not supplied with models 4108/4128.)
2. Insert a screwdriver into the slot of the adjusting screw and hold it steady.
3. Loosen the locking nut with a wrench by turning counterclockwise.
4. Throttle the outlet line until the differential pressure at the pump port reaches the desired level:

If the pressure fails to reach this level with the throttling valve closed, turn the adjusting screw inward (clockwise) until the desired pressure is reached. (Adjusting clockwise raises the pressure setting.)

If the pressure reaches the desired level before the throttling valve is completely closed, turn the adjusting screw outward (counter clockwise) until the desired pressure is reached. (Adjusting counterclockwise lowers the pressure setting.)

5. Retighten the nut to lock the setting in place and replace the acorn nut, if supplied.
6. Recheck the pressure gauge reading.

#### **4200/4300 Series**

Unless otherwise specified at the time of order, all 4200/4220 and 4300/4320 pumps with an internal relief valve are supplied with the standard spring, with a range of 10-200 psi (0.5 - 14 bar) in size 2 pumps and 30-225 psi (2 - 16 bar) in all other sizes, set to relieve at 90 psi (6 bar) full-bypass.

To adjust the relief setting within the range of a given spring's capability:

1. With a small wrench, hold the adjusting screw steady.
2. With a second wrench, loosen the locking nut by rotating counterclockwise.
3. Throttle the outlet line until the differential pressure at the pump port reaches the desired level:

If the pressure fails to reach this level with the throttling valve closed, turn the adjusting screw inward (clockwise) until the desired pressure is reached. (Adjusting clockwise raises the pressure setting.)

If the pressure reaches the desired level before the throttling valve is completely closed, turn the adjusting screw outward (counter clockwise) until the desired pressure is reached. Adjusting counterclockwise lowers the pressure setting.)

4. Retighten the nut to lock the setting in place.
5. Recheck the pressure gauge reading.

### Strainer Protection

Strainers are used to remove contaminated particles from the fluid system and extend pump life. Every pump should be protected from these particles by a strainer in the suction line.

Strainer size and mesh of screen are determined by the rate of flow and viscosity of the fluid. Consult the strainer manufacturer for recommendations.

Never use a strainer with a built in automatic by-pass on the suction line set to open under 30" Hg. vacuum.

Install the strainer according to the designated direction of flow, locating it so that it is accessible for servicing. Use a duplex type strainer when shutdown during service is not possible.

Provide a vacuum gauge in the suction line for determining when the strainer requires cleaning.

Make certain strainer baskets are properly reinforced so as not to collapse under 30" Hg. vacuum.



### WARNING

All Tuthill pumps contain residual hydraulic oil from the factory test. Determine if this is compatible with the fluid you are pumping. If the fluid is incompatible, consult the factory.

If the pump is to operate at elevated temperatures, it should be brought up to operating temperature gradually. Rapid or sudden introduction of liquid at an elevated temperature into the cold liquid chamber of the pump could cause damage to the seal or other internal parts.

Do not run the pump dry. This could cause severe damage to the seal, bushings and/or metal parts.

### Startup

Prior to starting the pump, double-check the following:

- Pressure and vacuum gauges should be installed as close as possible to the pump.
- Rotate pump shaft to ensure it turns freely without binding.
- Recheck alignment and ensure all guards are in place.
- Make sure piping is independently supported and no strain is being transmitted to the pump.
- Make sure the safety relief valve is installed correctly.
- Check pump rotation.
- Open suction and discharge gate valves.
- Check for any leaks once gate valves are open.

After completing these checks the pump can be started.



### CAUTION

The pump should not be run dry. If after approximately 60 seconds there is no discharge of liquid, stop the pump and investigate the possible cause.

Failure to comply with this could cause severe damage to internal seals, bushings and/or metal parts.

**Pump Performance Data**

<b>size</b>	<b>capacity--gpm (lpm)</b>	<b>size</b>	<b>capacity--gpm (lpm)</b>
4101/4121	.3 (1)	4202/4222/4302/4322	8 (30)
4103/4123	1.6 (6)	4203/4223/4303/4323	17 (64)
4104/4124	2.7 (10)	4204/4224/4304/4324	36 (136)
4105/4125	4.9 (18)	4205/4225/4305/4325	61 (231)
4108/4128	12.9 (49)	4206/4226/4306/4326	84 (318)

Based on pumping a liquid of 200 SSU (40 cps) viscosity at 100 psi (7 bar) and 1750 rpm.

Based on pumping a liquid of 200 SSU (40 cps) viscosity at 50 psi (3 bar) and 1750 rpm.

**Service**



**WARNING**

Failure to follow these instructions could result in serious bodily injury or death.

Do not attempt to work on any Tuthill pump installation before completing the following steps:

Disconnect the drive so that it cannot be started while work is being performed.

Review the Material Safety Data Sheet (MSDS) applicable to the liquid being pumped to determine its characteristics and the precautions necessary to ensure safe handling.

Vent all pressure within the pump through the suction or discharge lines.

All Tuthill pumps contain residual hydraulic oil from the factory production test. Determine if this is compatible with the fluid you are pumping. If the fluid is incompatible, consult the factory.



**4100/4120 Models**

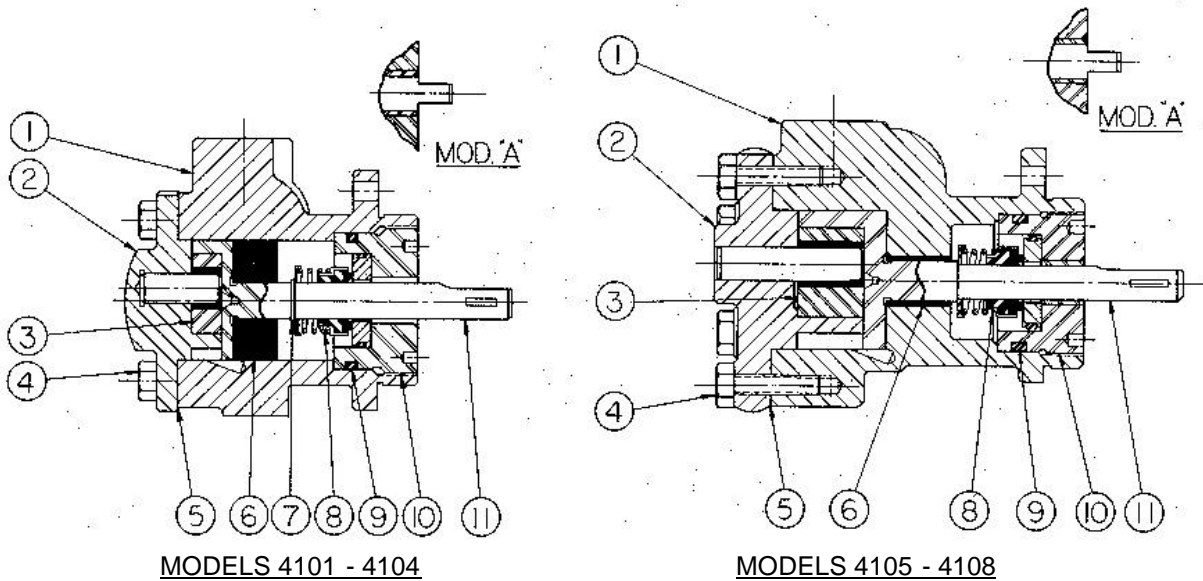

item	description
1	housing
2	cover assembly
3	idler gear
4	cover screws
5	cover gasket
6	housing bushing

item	description
7	retaining ring*
8	mechanical seal
9	O-ring
10	housing plug
11	rotor

\*Models 4101/4121, 4103/4123 and 4104/4124 only.

**Seal Replacement**

The seal assembly in 4100/4120 pumps can be changed without disassembly of the rest of the pump.

1. Place the pump in a vise with the shaft facing up so that one jaw grips across the two ports. Do not tighten excessively as the pump housing may become distorted.
2. Inspect the shaft at the keyway, flat or tang. Any burrs will interfere with removal of the housing plug and bearing assembly.
3. Remove the housing plug with a face-type spanner wrench, available from Tuthill as part number 0L506.
4. Remove the seal from the shaft. The rubber boot will be bonded to the shaft, so it is necessary to push down on the seal to break this bond. Grasp the metal outer shell with any suitable device and pull the seal assembly upward. Remove the spring and washer.
5. Models 4101/4121, 4103/4123 and 4104/4124 have a retaining ring on the shaft to back up the seal assembly. Do not remove this retaining ring unless you are completely disassembling the pump. Models 4105/4125 and 4108/4128 do not have a retaining ring. A step on the shaft is used as the seal backup.
6. Remove the stationary seal face from the housing plug by pressing out from the opposite side.

7. If damaged, remove the o-ring from the OD of the housing plug.
8. Clean all parts thoroughly using great care to eliminate all dirt.
9. Oil the shaft with a suitable lubricating oil. (If the pump has an EPR seal, apply a silicon-based lubricant instead.)
10. Apply the appropriate lubricant to the inside of the new seal assembly.
11. Install the seal head.

For standard full length shafts with flat and/or keyway:

- a. Place seal assembly on the pump shaft.
- b. Push seal down with your fingers to a position approximately half way down the shaft.

For modification "A" tang shafts:

- a. Use a tapered plastic sleeve. This is available from Tuthill as part number 1LPF531-7010.
- b. Lubricate the sleeve.
- c. Place seal assembly on the sleeve. The tapered end of the sleeve fits into the spring end of the seal assembly.
- d. Place the slotted end of the sleeve on a bench. Press down on the carbon face of the seal with your fingers and slide the seal to about the midpoint on the sleeve.
- e. Place the slotted end of the sleeve over the tang on the pump shaft. Line up the outside diameters of the sleeve and shaft by eye.
- f. Push seal down with your fingers so that it passes from the sleeve to a position approximately halfway down the shaft.

12. Press the stationary face completely into the housing plug. The lapped surface must be up. Protect this lapped surface by covering it with a piece of paper when pressing down on the face. Use your fingers for this operation.
13. Place a new o-ring on the OD of the housing plug, if required, and lubricate.
14. Lubricate the carbon face liberally.
15. Re-assemble the housing plug into position over the pump shaft. Do not nick the seal face by hitting the pump shaft. Tighten the housing plug with the spanner wrench. The seal will automatically be positioned by this operation.
16. If the pump is equipped with a ball bearing (modification K), press the bearing onto the shaft. Press on the bearing inner race with a suitable sleeve. Do not hammer into position or press on the bearing outer race.
17. Check pump for free rotation by turning the shaft with a suitable wrench. There will be a definite resistance to turning because of the seal load. The pump must turn freely without binding.

### Disassembly of Pump

1. Follow steps 1-7 from "Seal Replacement" above to remove the seal assembly.
2. On models 4101/4121, 4103/4123 and 4105/4125, remove the retaining ring from the shaft.
3. Mark the cover and housing of the pump for proper re-assembly.
4. Remove the cover screws, cover, idler and rotor from the housing.

### Inspection

1. Check the housing, rotor, idler gear, idler pin and cover for wear and chipped or broken teeth. There must not be any deep scratches or grooves on any of the following:
  - the ID surface of the housing
  - the OD of the rotor
  - the end face of the rotor
  - the OD of the idler
  - both faces of the idler
  - the inside surfaces of the cover, including the crescent.
2. Replace worn parts as needed.
3. The rotor should be positioned in the housing and checked for clearance in the bearing. The shaft must turn freely without any detectable side play. Any side play will require replacement of the housing, bracket, rotor, or all three parts.

### Assembly of Pump

1. Clean all parts thoroughly using great care to eliminate all dirt.
2. Install the rotor in the pump housing.
3. Apply the gasket to the cover. Use a new gasket if the old one is damaged. (Models 4101/4121 and 4108/4128 are also supplied with an o-ring between the cover and housing. Replace if damaged.)
4. Place the idler gear on the pin in the cover assembly.
5. Place the cover assembly with gear on the pump, aligning the matching marks for proper location.
6. Install the cover screws. Tighten gradually, alternating from a screw on one side to a screw on the opposite side.
7. Install the retaining ring on models 4101/4121, 4103/4123 and 4104/4124.
8. Follow steps 8-17 from "Seal Replacement" above to install the seal assembly

### Changing Rotation

Model 4100/4120 pumps are bi-directional and will work equally well in either direction with no modification. However, if outfitted with an internal relief valve (V option), these pumps become rotational. Rotation cannot be changed in the field unless the housing is replaced.

## 4200/4220 Models

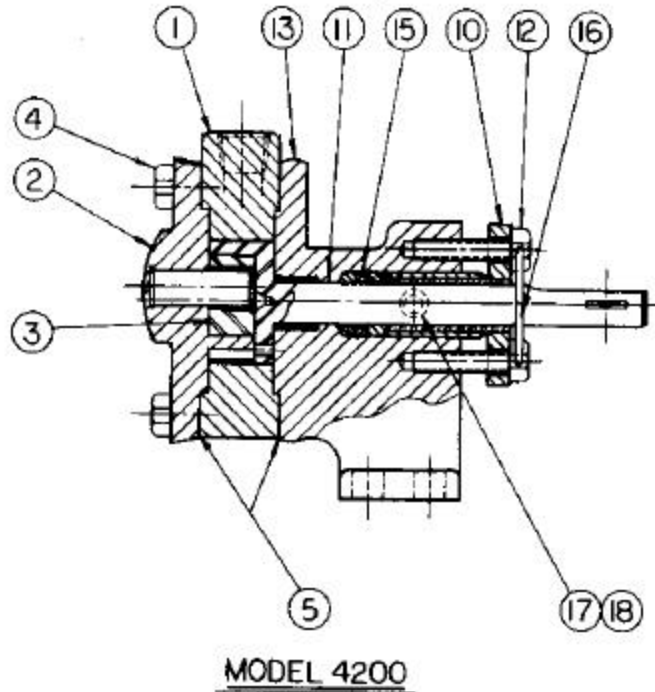

item	description	item	description
1	housing	10	gland assembly
2	cover assembly	13	bracket
3	idler gear	15	packing
4	cover screws	16	retaining wire
5	cover gaskets	17	pipe plug
11	rotor	18	grease cup
12	packing gland screws		

### Lubrication

Model 4200/4220 pumps are provided with a grease cup or grease fitting at the outer bearing which also lubricates the packing. A good grade of medium cup grease, such as Fiske Bros. Lubriplate #910, should be used. Apply until visible at the outer end of the packing gland. If the pump is overheating, it may be due to a lack of lubricant. Add lubricant as needed or at least every 60 days or 500 hours of operation.

### Repacking

1. Grip the pump firmly across the ports and opposite side of the housing in a vise with the shaft end up.
2. Remove the lock wire and packing gland screws.
3. Inspect the shaft at the flat and keyway area. Any burrs will interfere with removal of the packing gland. Use a small, fine file if necessary.
4. Slide the packing gland off the shaft.
5. Remove the old packing from the bracket.

6. Inspect the shaft. If the shaft is too badly worn or scored at the packing area, the rotor must be replaced.
7. Position the new packing over the shaft and slide into the bracket.
8. Install the packing gland and the screws. Take care when tightening up the packing gland screws so as not to cause undue pressure in the stuffing box. Pull up firmly on the packing gland screws, back off to finger tight and lock the screws in place with the lock wire.

Aluminum packing is the standard, with Teflon packing an option. Following is a table of packing sizes:

size	ID	OD	length
2	5/8"	59/64"	3/4"
3 & 4	3/4"	1 1/8"	3/4"
5 & 6	1"	1 1/2"	1 1/2"

**4300 Models**

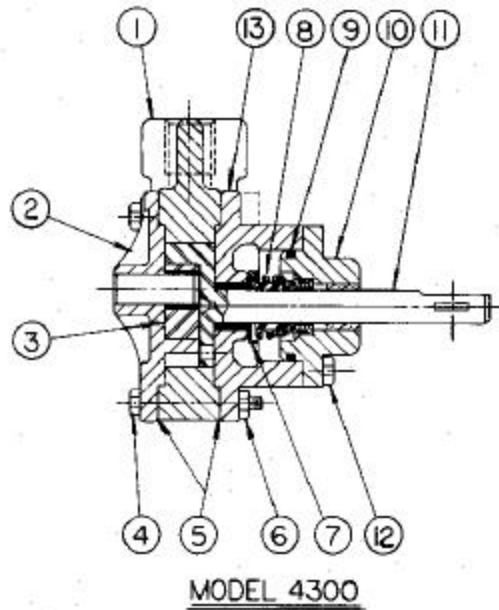

item	description	item	description
1	housing	8	mechanical seal
2	cover assembly	9	o-ring
3	idler gear	10	housing plug
4	cover screws	11	rotor
5	cover gaskets	12	cap screws
6	cover screw nuts	13	bracket
7	retaining ring		

**Seal Replacement**

1. Grip the pump firmly across the ports and opposite side of the housing in a vise with the shaft end up.
2. Remove any burrs or nicks on the shaft. Use a small, fine file if needed.

3. Remove the cap screws.
4. Slide the housing plug off the shaft.
5. Remove the stationary seat of the seal from the housing plug.
6. Slide the seal head off the shaft.
7. Polish the pump shaft with crocus cloth or very fine sandpaper and clean the seal chamber thoroughly with a clean cloth. This will prevent damage to the new seal and ease installation.
8. Place the new seal head on the shaft and slide into place.
9. Install the new stationary seat into the housing plug.
10. Place the housing plug on the shaft and slide into place.
11. Align the mounting holes and reinstall the cap screws.

**4320 Models**

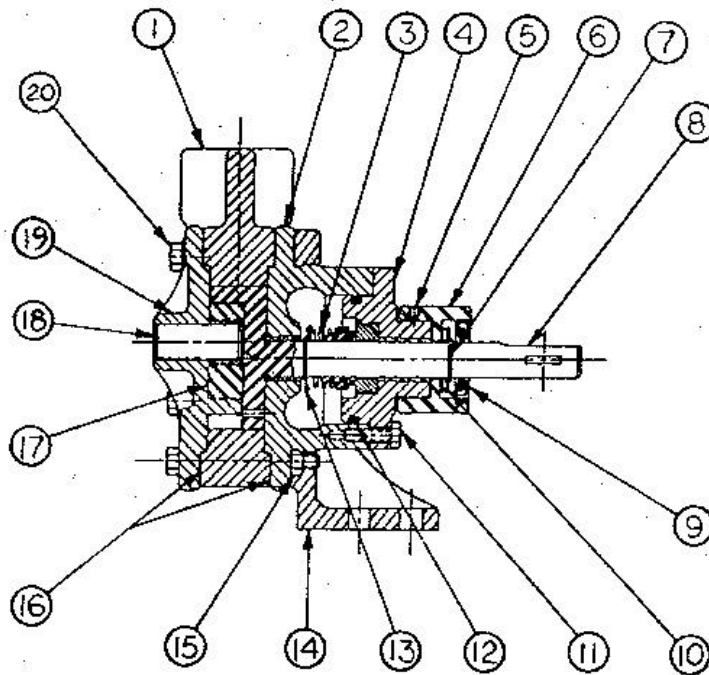

item	description	item	description
1	housing	11	cap screws
2	bracket	12	o-ring
3	mechanical seal	13	retaining ring
4	housing plug	14	mounting foot (optional)
5	set screw	15	cover screw nuts
6	adjustment sleeve	16	cover gaskets
7	retaining ring	17	idler gear
8	rotor	18	idler pin
9	lip seal	19	cover
10	thrust bearing	20	cover screws

### Seal Replacement and Resetting of Clearances

1. Grip the pump firmly across the ports and opposite side of the housing in a vise with the shaft end up.
2. Remove any burrs or nicks on the shaft. Use a small, fine file if needed.
3. Remove the lip seal from the adjustment sleeve.
4. Loosen the set screw in the adjustment sleeve.
5. Rotate the adjustment sleeve clockwise until it makes contact with the housing plug.
6. Remove the retaining ring from the shaft.
7. Remove the cap screws at the shaft end.
8. Slide the housing plug and thrust bearing off the shaft.
9. Remove the stationary seat of the seal from the housing plug.
10. Slide the seal head off the shaft.
11. Polish the pump shaft with crocus cloth or very fine sandpaper and clean the seal chamber thoroughly with a clean cloth. This will prevent damage to the new seal and ease installation.
12. Oil the shaft with an appropriate lubricating oil.
13. Place the new seal head on the pump shaft and push down with your fingers to a position approximately half way down the shaft.
14. Press the new stationary seat into the housing plug. Make sure the lapped surface is facing up. Protect the lapped surface by covering it with a piece of paper when pressing down on the face. Use your fingers for this operation. The stationary seat must be seated squarely in the housing plug.
15. Place a new o-ring on the OD of the housing, if required, and lubricate with oil.
16. Place the housing plug on the shaft and slide into place. Use care when placing into position over the pump shaft. Do not nick the seal face by hitting the pump shaft.
17. Align the mounting holes and reinstall the cap screws.
18. Place the thrust bearing into the adjustment sleeve.
19. Replace the retaining ring on the shaft.
20. Fill the bearing/adjustment sleeve with light grease for lubrication of the bearing.
21. Press the lip seal into the adjustment sleeve.
22. Rotate the adjustment sleeve counterclockwise until the rotor makes contact with the bracket assembly. At this time the rotor shaft will not turn freely.
23. Rotate the adjustment sleeve clockwise until the rotor does turn freely.
24. Tighten the set screw in the adjustment sleeve.

<b>4200/4220 and 4300/4320 Models</b>
---------------------------------------

**Disassembly of Pump**

The seal or packing must be removed before the pump can be disassembled.

1. Mark the cover, housing and bracket for proper re-assembly.
2. Remove the cover screws, cover, housing, idler and rotor from the bracket.

**Inspection**

1. Check the pump housing, rotor, idler gear, idler pin and cover for wear and chipped or broken teeth. There must not be any deep scratches or grooves on any of the following:
  - the ID surface of the housing
  - the OD of the rotor
  - the end face of the rotor
  - the OD of the idler
  - both faces of the idler
  - the inside surfaces of the cover, including the crescent.
2. Replace worn parts as needed.
3. The rotor should be positioned in the housing or bracket and checked for clearance in the bearing. The shaft must turn freely without any detectable side play. Any side play will require replacement of the housing, bracket, rotor, or all three parts.

**Assembly of Pump**

1. Clean all parts thoroughly using great care to eliminate all dirt.
2. Install the rotor in the pump bracket.
3. Position the selected gaskets over the mounting registers of the bracket and cover.

Note: Gaskets are supplied with each pump so that proper internal clearances are maintained. Composite gaskets are supplied for standard pumping applications and consist of a steel shim enclosed in a Buna-N rubber. The typical end clearances are as follows:

<b>pump size</b>	<b>end clearance</b>
2	.004 to .009"
3 & 4	.004 to .009"
5 & 6	.007 to .010"

When pumping thinner viscosity fluids, fluids that are not compatible with Buna-N, or a drop-off in capacity has occurred because of excessive end play of the rotor, plastic shim type gaskets should be used. These are available from Tuthill as spare parts. The minimum end clearances for proper pump operation are as follows:

<b>pump size</b>	<b>clearance</b>	<b>spare part number</b>
2	.001 to .002"	2M34-.003/.004/.005
3 & 4	.002 to .003"	3M34-.003/.004/.005
5 & 6	.003 to .005"	5C34-.003/.004/.005



4. Install the housing over the rotor head positioned on the bracket register.
5. Place the idler gear on the pin in the cover assembly and position in the housing register.
6. Align the matching marks for proper location.
7. Install the cover screws. Tighten gradually, alternating from a screw on one side to a screw on the opposite side.
8. Install the packing or seal, following the instructions for the specific model in question.
9. Check the end clearance.

### **Changing Rotation**

Model 4200/4220 pumps, and 4300/4320 pumps manufactured after 1996, are bi-directional and will work equally well in either direction of rotation with no modification.

However, if outfitted with an internal relief valve (V option), these pumps become rotational. Rotation cannot be changed in the field unless the cover/valve assembly is replaced.

Older 4300/4320 pumps (manufactured before 1996) are directional, carrying suffix designations of "-C" or "CC".

To change the rotation of these pumps:

1. Look at the pump from the shaft end with the ports up and note the location of the V notch in the bracket. If located at the top (12 o'clock), rotation is clockwise; if at the bottom (6 o'clock), counterclockwise.
2. Remove the cover screws so that the bracket moves freely.
3. Rotate the bracket 180°.
4. Align the mounting holes and reinstall the cover screws.

If outfitted with an internal relief valve (V option), rotation cannot be changed in the field unless the cover/valve assembly is replaced.

<b>Troubleshooting</b>
------------------------

**Symptom: No fluid is delivered.****What to look for:**

- Power is not on.
- Net positive suction head available (NPSHA) is lower than required for the inlet conditions and the vapor pressure of the liquid pumped. Calculate NPSHA and redesign piping if necessary.
- Leaks in suction line or port passages. These can be detected by submerging the pressure line from the discharge side of the pump into a pail of liquid where the air will be seen in the form of bubbles.
- Direction of shaft rotation is incorrect.
- Pump shaft is not rotating. The coupling is defective or the tongue and groove are not engaged.
- The relief valve setting is too low. Liquid is discharging through the by-pass port.

**Symptom: Capacity is too low.****What to look for:**

- There are leaks in the suction line.
- Suction losses are too high. The suction lift is too great or the suction line too small or too long. This can be detected by installing a vacuum gauge directly at the pump suction. The maximum vacuum at the pump suction should never exceed 15" of mercury. Vaporization caused by higher vacuums will generally result in capacity drop-off. Suction conditions must be redesigned.
- Pump speed is too slow.
- The strainer is too small or obstructed.
- The suction port or pipe is not immersed deeply enough in the liquid.
- Piping is improperly installed, permitting an air pocket to form in the pump.
- Increased clearances or wear in the pump will sometimes cause the pump to deliver an insufficient supply of fluid. This can generally be corrected by reducing the thickness of the cover gaskets. A folded gasket or a slight amount of dirt can exaggerate the problem and cause leakage.

**Symptom: Pump works spasmodically.****What to look for:**

- Leaky suction line.
- Varying suction conditions.
- Air or vapor in the fluid.

**Symptom: Excessive power draw.**

**What to look for:**

- Pressure too high.
- Liquid is more viscous than originally expected.
- Suction or discharge lines obstructed.
- Insufficient horsepower.
- Drive shaft and pump misaligned.
- Pump binding due to insufficient end clearance.
- Pump shaft is bent.
- Misalignment within the pump due to bad piping or poor installation, causing strain or distortion.

**Symptom: Pump is noisy.**

**What to look for:**

- Pump is cavitating due to inadequate suction conditions.
- Misalignment of coupling.
- Coupling is set too close to pump.
- Vibration of pump due to worn or bent shaft.
- Air leaks on suction side of pump or air entrainment in the fluid.

**Symptom: Pump leaks.**

**What to look for:**

- Cover bolts need tightening or cover gasket is defective.
- Worn or defective seal.

<b>Material Returns</b>
-------------------------

If it becomes necessary to return a pump to the factory, a Return Goods Authorization (RGA) must be obtained from either your local Authorized Distributor or our Alsip plant. No RGA can be issued until a completed Material Safety Data Sheet (MSDS) has been forwarded to our Alsip plant and return of the pump approved.

- Tuthill pumps are precision built and must be handled with care.
- Pumps must be drained of all fluid and the ports plugged to prevent foreign material from getting into the pump.
- Pumps must be packaged securely to prevent damage while in transit.

Notes:



**TUTHILL**  
**Pump Group**

12500 South Pulaski Road  
Alsip, Illinois USA 60803  
Tel 708 389-2500 Fax 708 388-0869  
email: [tuthillpump@tuthill.com](mailto:tuthillpump@tuthill.com)  
[www.tuthill.com](http://www.tuthill.com)